

## THREE-PHASE SILICON BRIDGES

## SKBPC35005--SKBCP3516

### FEATURES

- Rating to 1600V PRV
- Surge overload rating to 500 Amperes peak
- Ideal for printed circuit board
- Reliable low cost construction utilizing molded plastic technique results in inexpensive product
- Lead solderable per MIL-STD-202 method 208



### MAXIMUM RATINGS AND ELECTRICAL CHARACTERISTICS

Ratings at 25°C ambient temperature unless otherwise specified.

		S	S	S	S	S	S	S	S	S	S	UNITS
		KBPC 35005	KBPC 3501	KBPC 3502	KBPC 3504	KBPC 3506	KBPC 3508	KBPC 3510	KBPC 3512	KBPC 3514	KBPC 3516	
Maximum recurrent peak reverse	$V_{RRM}$	50	100	200	400	600	800	1000	1200	1400	1600	V
Maximum RMS voltage	$V_{RMS}$	35	70	140	280	420	560	700	840	980	1120	V
Maximum DC blocking voltage	$V_{DC}$	50	100	200	400	600	800	1000	1200	1400	1600	V
Maximum average forward Output current @ $T_A=25^\circ\text{C}$	$I_{F(AV)}$	35.0										A
Peak forward surge current 8.3ms single half-sine-wave superimposed on rated load	$I_{FSM}$	500										A
Maximum instantaneous forward voltage @12.0A	$V_F$	1.19										V
Maximum reverse current @ $T_A=25^\circ\text{C}$ at rated DC blocking voltage @ $T_A=100^\circ\text{C}$	$I_R$	10 5.0										m A
Thermal resistance junction to case at DC Operation per bridge	$R_{JC}$	1.16										K/W
Thermal resistance case to heatsink Mounting surface, smooth, flat and gread	$R_{CS}$	0.2										K/W
Operating junction temperature range	$T_J$	- 40 ---- + 150										°C
Storage temperature range	$T_{STG}$	- 40 ---- + 150										°C

**THREE-PHASE SILICON BRIDGES**

**SKBPC35005--SKBCP3516**

**PACKAGE OUTLINE DIMENSIONS**

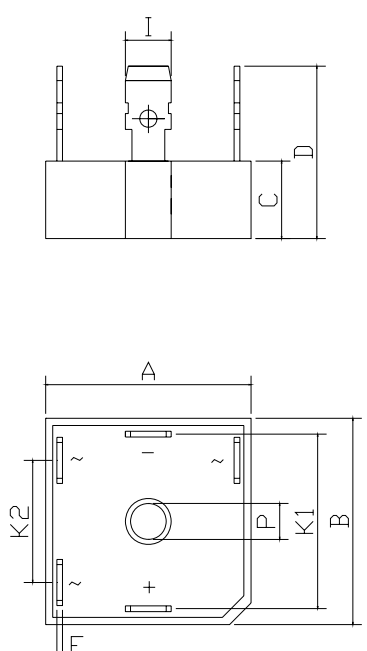

SKBPC		
Dim	Min	Max
A	28.10	28.50
B	28.10	28.50
C	10.85	11.15
D	21.0min	
E	0.8 Typical	
I	6.20	6.50
K1	23.00	24.00
K2	14.90	15.60
P	Ø5.2Typical	
All Dimensions in mm		

**PACKAGE INFORMATION**

Device	Package	Shipping
SKBPC35005--SKBPC3516	SKBPC	50Units/Box

**THREE-PHASE SILICON BRIDGES**

**SKBPC35005--SKBCP3516**

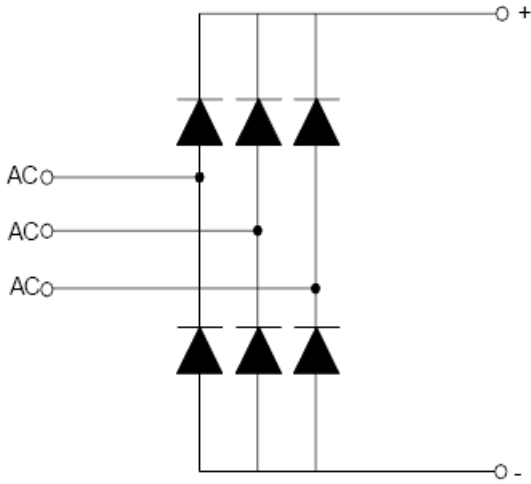

AVERAGE FORWARD OUTPUT CURRENT,  
AMPERES

**FIG.1 -- FORWARD DERATING CURVE**

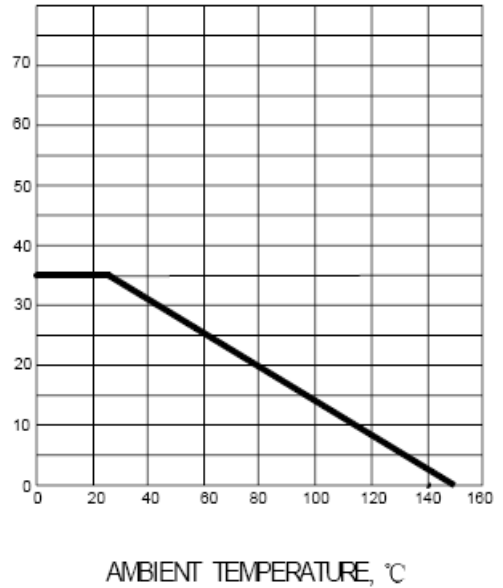

**FIG.2 -- TYPICAL FORWARD CHARACTERISTIC**

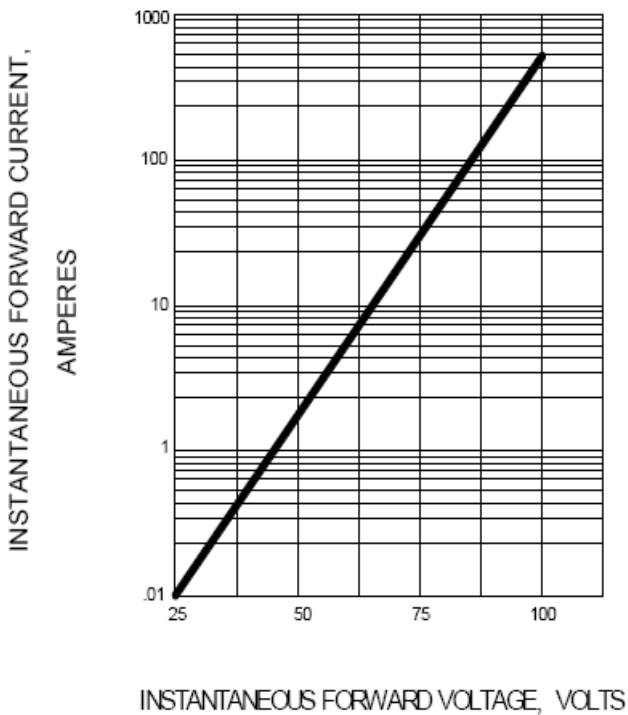

**FIG.3-- TYPICAL REVERSE CHARACTERISTIC**

INSTANTANEOUS REVERSE CURRENT,  
MICRO AMPERES

