

SKCD 04 C 060 I HD

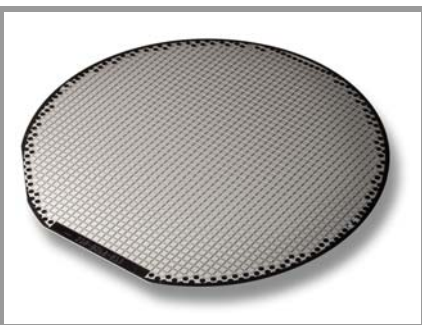

CAL-DIODE

$I_F = 10 \text{ A}$

$V_{RRM} = 600 \text{ V}$

Size: 2 mm x 2 mm

SKCD 04 C 060 I HD

Features

- high current density
- easy paralleling due to a small forward voltage spread
- positive temperature coefficient
- very soft recovery behavior
- small switching losses
- high ruggedness
- compatible to thick wire bonding
- compatible to standard solder processes

Typical Applications*

- freewheeling diode for IGBT



SKCD

Absolute Maximum Ratings			
Symbol	Conditions	Values	Unit
V_{RRM}	$T_j = 25 \text{ }^\circ\text{C}$, $I_R = 0.1 \text{ mA}$	600	V
$I_{F(AV)}$	$T_s = 80 \text{ }^\circ\text{C}$, $T_j = 175 \text{ }^\circ\text{C}$	11	A
I_{FSM}	10 ms	$T_j = 25 \text{ }^\circ\text{C}$	75
	sin 180°	$T_j = 150 \text{ }^\circ\text{C}$	65
T_{jmax}		175	°C

Electrical Characteristics					
Symbol	Conditions	min.	typ.	max.	Unit
i^2t	$T_j = 150 \text{ }^\circ\text{C}$, 10 ms, sin 180°			21	A ² s
I_R	$T_j = 25 \text{ }^\circ\text{C}$, $V_{RRM} = 600 \text{ V}$			0.10	mA
	$T_j = 150 \text{ }^\circ\text{C}$, $V_{RRM} = 600 \text{ V}$				mA
V_F	$T_j = 25 \text{ }^\circ\text{C}$, $I_F = 7 \text{ A}$		1.35		V
	$T_j = 150 \text{ }^\circ\text{C}$, $I_F = 7 \text{ A}$		1.31		V
$V_{(TO)}$	$T_j = 150 \text{ }^\circ\text{C}$		0.85		V
r_T	$T_j = 150 \text{ }^\circ\text{C}$		66.7		mΩ

Dynamic Characteristics					
Symbol	Conditions	min.	typ.	max.	Unit
t_{rr}	$T_j = 25 \text{ }^\circ\text{C}$, 6 A, 300 V, 520 A/μs				μs
t_{rr}	$T_j = 150 \text{ }^\circ\text{C}$, 6 A, 300 V, 520 A/μs				ns
Q_{rr}	$T_j = 25 \text{ }^\circ\text{C}$, 6 A, 300 V, 520 A/μs				μC
Q_{rr}	$T_j = 150 \text{ }^\circ\text{C}$, 6 A, 300 V, 520 A/μs		0.89		μC
I_{rrm}	$T_j = 25 \text{ }^\circ\text{C}$, 6 A, 300 V, 520 A/μs				A
I_{rrm}	$T_j = 150 \text{ }^\circ\text{C}$, 6 A, 300 V, 520 A/μs		11.2		A

Thermal Characteristics					
Symbol	Conditions	min.	typ.	max.	Unit
T_j		-40		175	°C
T_{stg}		-40		175	°C
T_{solder}	10 min.			250	°C
T_{solder}	5 min.			320	°C
$R_{th(j-s)}$	sold. on 0,38 mm DCB, reference point on copper heatsink close to the chip		3		K/W

Mechanical Characteristics			
Symbol	Conditions	Values	Unit
Raster size		2 x 2	mm ²
Area total		4	mm ²
Anode		bondable (Al)	
Cathode		solderable (Ag/Ni)	
Wire bond		Al, diameter ≤ 500 μm	
Package		wafer frame	
Chips / Package		2661 (5" Wafer)	pcs

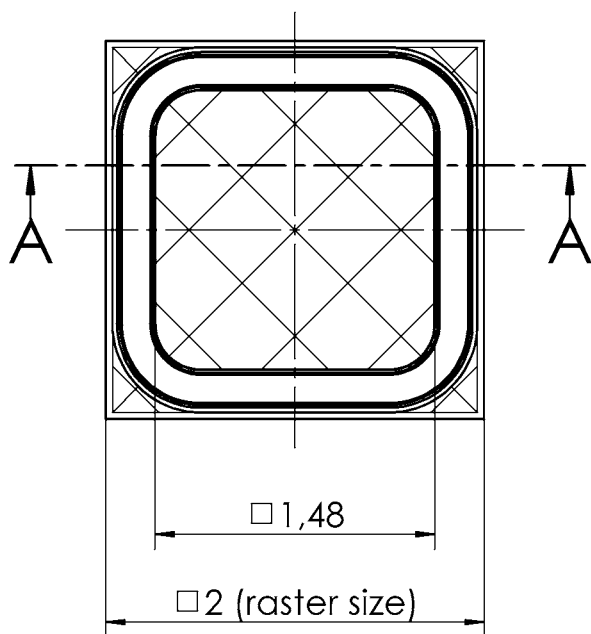
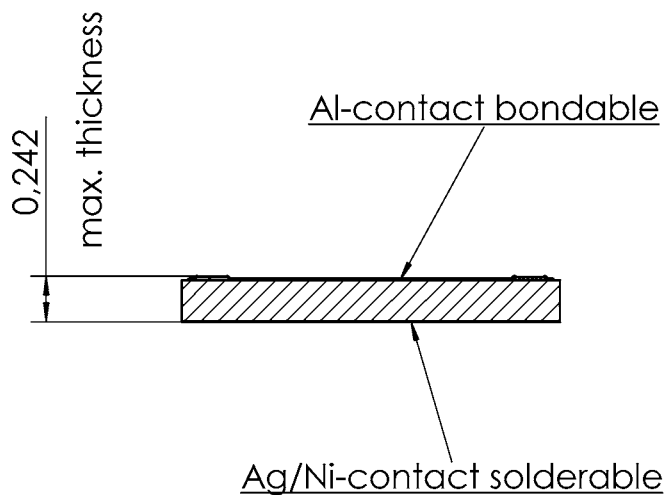

die size after cutting
 □ 1,97 mm

This is an electrostatic discharge sensitive device (ESDS), international standard IEC 60747-1, Chapter IX

* The specifications of our components may not be considered as an assurance of component characteristics. Components have to be tested for the respective application. Adjustments may be necessary. The use of SEMIKRON products in life support appliances and systems is subject to prior specification and written approval by SEMIKRON. We therefore strongly recommend prior consultation of our personal.