



## Power Bridge Rectifiers

### SKD 30

#### Features

- Isolated metal case with screw terminals
- Blocking voltage up to 1600 V
- High surge currents
- Easy chassis mounting
- UL recognized, file no. E 63 532

#### Typical Applications

- Three phase rectifiers for power supplies
- Input rectifiers for variable frequency drives
- Rectifiers for DC motor field supplies
- Battery charger rectifiers
- Recommended snubber network:  
RC: 0.1  $\mu$ F, 50  $\Omega$  ( $P_R = 1$  W)

- 1) Freely suspended or mounted on an insulator
- 2) Mounted on a painted metal sheet of min. 250 x 250 x 1 mm

$V_{RSM}, V_{RRM}$ V	$V_{VRMS}$ V	$I_D = 30$ A ( $T_c = 98$ °C) Types	$C_{max}$ $\mu$ F	$R_{min}$ $\Omega$
200		SKD 30/02A1		0,15
400		SKD 30/04A1		0,3
800		SKD 30/08A1		0,5
1200		SKD 30/12A1		0,75
1400		SKD 30/14A1		0,9
1600		SKD 30/16A1		1

Symbol	Conditions	Values	Units
$I_D$	$T_a = 45$ °C, isolated <sup>1)</sup> $T_a = 45$ °C, chassis <sup>2)</sup>	6,5 15	A A
$I_{DCL}$	$T_a = 45$ °C, isolated <sup>1)</sup> $T_a = 45$ °C, chassis <sup>2)</sup> $T_a =$ °C,	6,5 15	A A A
$I_{FSM}$	$T_{vj} = 25$ °C, 10 ms $T_{vj} = 150$ °C, 10 ms	370 320	A A
$i^2t$	$T_{vj} = 25$ °C, 8,3 ... 10 ms $T_{vj} = 150$ °C, 8,3 ... 10 ms	680 500	A <sup>2</sup> s A <sup>2</sup> s
$V_F$	$T_{vj} = 25$ °C, $I_F = 150$ A	max. 2,2	V
$V_{(TO)}$	$T_{vj} = 150$ °C	max. 0,85	V
$r_T$	$T_{vj} = 150$ °C	max. 12	m $\Omega$
$I_{RD}$	$T_{vj} = 25$ °C, $V_{RD} = V_{RRM}$ $T_{vj} =$ °C, $V_{RD} = V_{RRM} \geq V$	300	$\mu$ A $\mu$ A
$I_{RD}$	$T_{vj} = 150$ °C, $V_{RD} = V_{RRM}$ $T_{vj} =$ °C, $V_{RD} = V_{RRM} \geq V$	5	mA mA
$t_{tr}$	$T_{vj} = 25$ °C	25	$\mu$ s
$f_G$		2000	Hz
$R_{th(j-a)}$	isolated <sup>1)</sup> chassis <sup>2)</sup>	8,5 3,3	K/W K/W
$R_{th(j-c)}$	total	0,7	K/W
$R_{th(c-s)}$	total	0,1	K/W
$T_{vj}$		- 40 ... + 150	°C
$T_{stg}$		- 55 ... + 150	°C
$V_{isol}$	a. c. 50 ... 60 Hz; r.m.s.; 1 s / 1 min.	3000 / 2500	V~
$M_s$	to heatsink	5 $\pm$ 15 %	Nm
$M_t$	to terminals	1,5 $\pm$ 15 %	Nm
$a$			m/s <sup>2</sup>
$w$		125	g
$F_u$		25	A
Case		G 13	

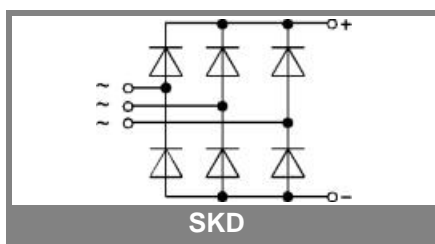

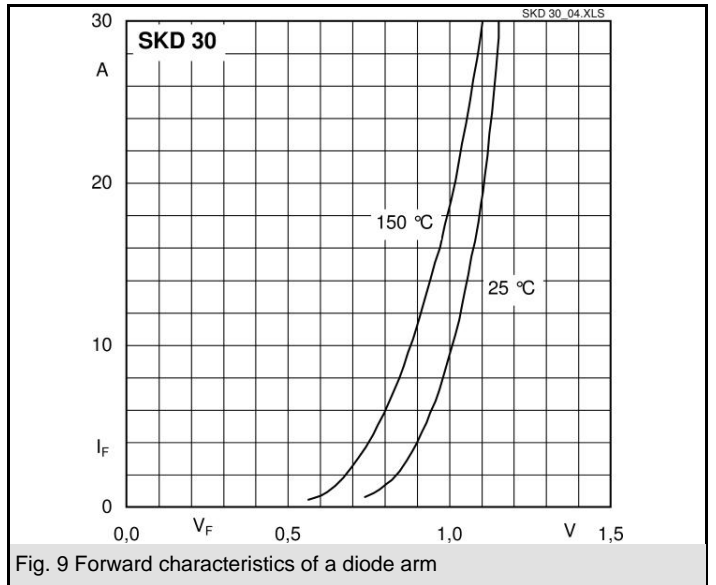
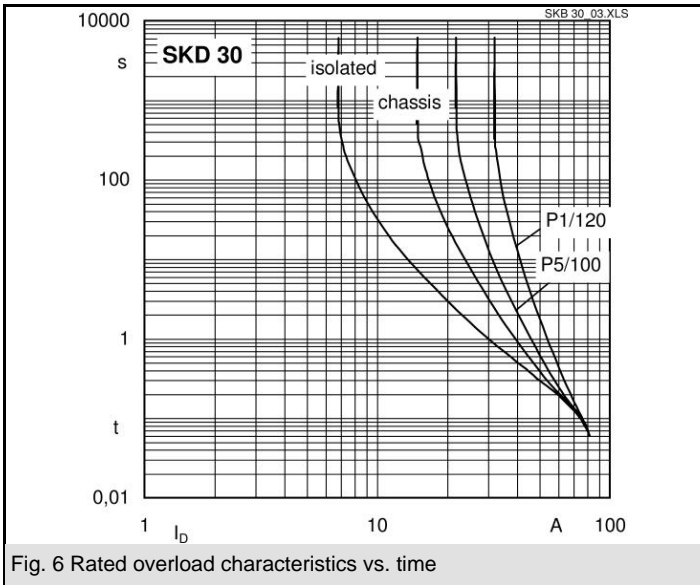
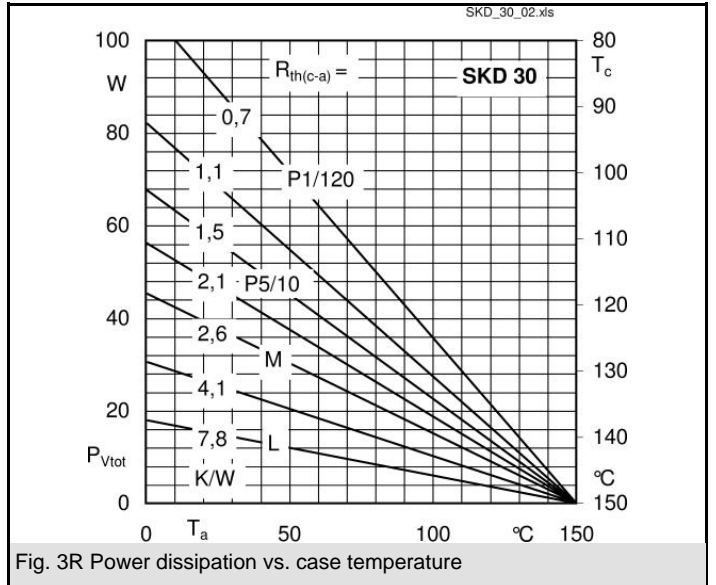
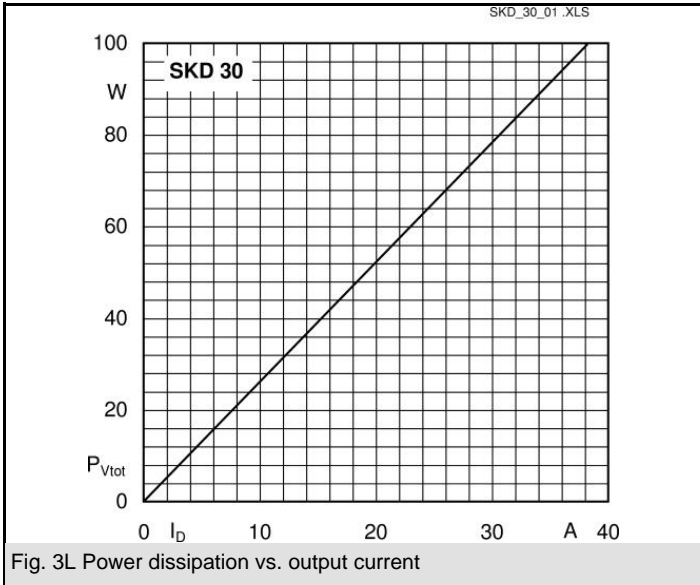

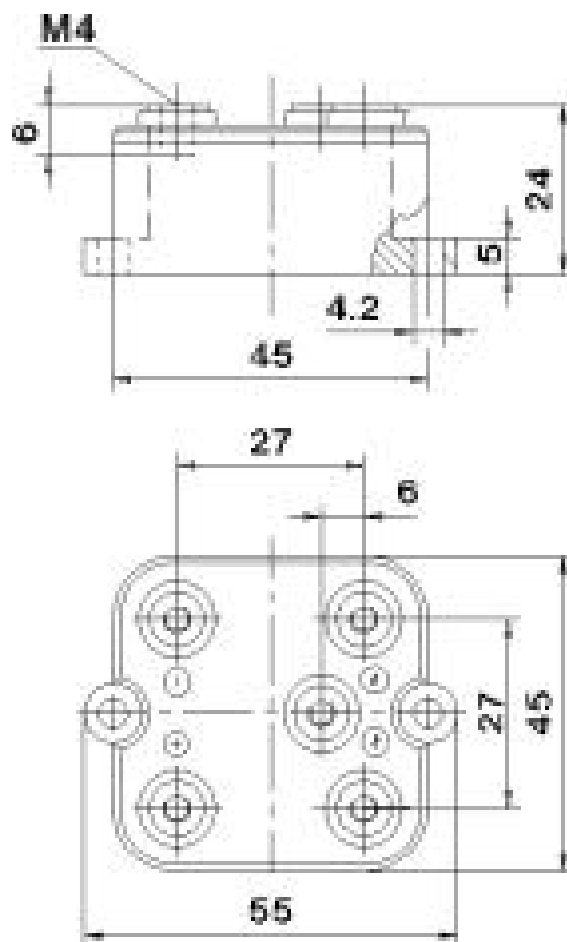

Case G 13

This technical information specifies semiconductor devices but promises no characteristics. No warranty or guarantee expressed or implied is made regarding delivery, performance or suitability.