

# Beidou/GPS Module

## Datasheet

Name: High-performance BD/GPS Module

Model No.: SKG09D

Revision: 001

Revision History:

Revision	Description	Approved	Date
001	Initial Release to 001	Woody	20140225

## General Description

The SKG09D is a high-performance GNSS all-in-one solution module that features super sensitivity, ultra low power and small form factor. The RF signal is applied to the antenna input of module, and a complete serial data message with position, velocity and time information is presented at the serial interface with NMEA protocol or custom protocol.

It is based on the high performance features of the single-chip architecture, Its  $-162\text{dBm}$  tracking sensitivity extends positioning coverage into place like urban canyons and dense foliage environment where the GNSS was not possible before. The small form factor and low power consumption make the module easy to integrate into portable device like PNDs, mobile phones, cameras and vehicle navigation systems.

## Applications

- LBS (Location Based Service)
- PND (Portable Navigation Device)
- Vehicle navigation system

- Mobile phone



Figure 1: SKG09D Top View

## Features

- BD B1/GPS L1/GALILEO/QZSS
- Ultra high sensitivity:  $-162\text{dBm}$
- Extremely fast TTFF at low signal level
- Ultra low power consumption
- $\pm 10\text{ns}$  high accuracy time pulse (1PPS)
- QZSS, SBAS (WAAS, EGNOS, MSAS, GAGAN)
- Small form factor:  $10.1 \times 9.7 \times 2.2\text{mm}$
- RoHS compliant (Lead-free)

## Pin Assignment

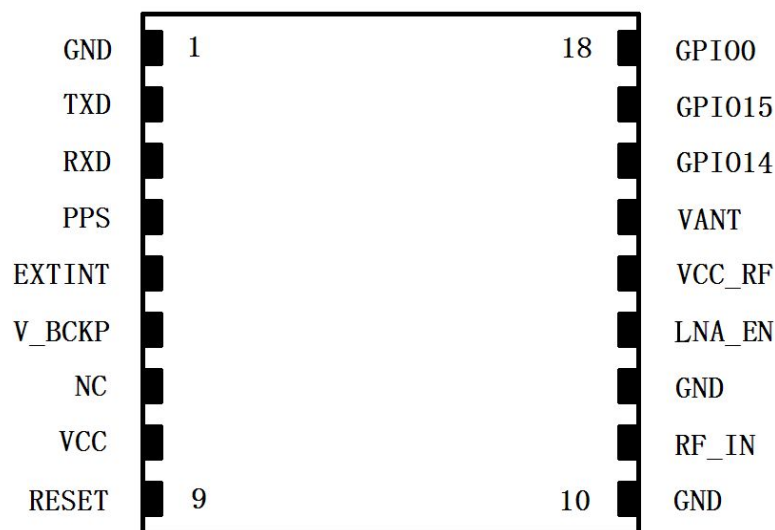

Figure 2: SKG09D Pin Package

## Pin Description

Pin No.	Pin name	I/O	Description	Remark
1	GND	G	Ground	Leave open if not used
2	TXD	O	UART Serial Data Output	Leave open if not used
3	RXD	I	UART Serial Data Input	Leave open if not used
4	PPS	O	Time Pulse Signal	Leave open if not used
5	EXTINT	I	External Interrupt	
6	V_BCKP	I	RTC and backup SRAM power	This pin may be connect to Battery or Power Supply(2.0~4.2V)
7	NC			Leave open if not used
8	VCC	I	Active Antenna External Voltage Supply	Operating range: 3.0V to 4.2V
9	RESET	I	Module Reset (Active Low)	Leave open if not used
10	GND	G	Ground	
11	RF_IN	I	GPS Signal Input	50Ω@1.57542GHz, DC block inside
12	GND	G	Ground	
13	LNA_EN	O	Active antenna or ext. LNA control pin in power save mode.	
14	VCC_RF	O	General Purpose I/O	Leave open if not used
15	VANT	I	Active Antenna External Voltage Supply	Leave open if not used
16	GPIO14	I/O	General Purpose I/O	Leave open if not used
17	GPIO15	I/O	General Purpose I/O	Leave open if not used
18	GPIO0	I/O	General Purpose I/O	Leave open if not used

## Interfaces Configuration

### Power Supply

Regulated power for the SKG09D is required. The input voltage Vcc should be 3.0V to 4.2V range, current is no less than 100mA. Suitable decoupling must be provided by external decoupling circuitry (10uF and 1uF). It can reduce the Noise from power supply and increase power stability.

Main power supply Vcc current varies according to the processor load and satellite acquisition. Maximum Vcc peak current is about 40 mA during acquisition.

### Backup Battery Power

In case of a power failure on pin Vcc, real-time clock and backup RAM are supplied through pin V\_BCKP. This enables the SKG09D BD/GPS Receiver to recover from power failure with either a hot start or a warm start (depending on the duration of Vcc outage). If no Backup Battery is connected, the receiver performs a cold start upon powered up.

Backup Battery Power V\_BCKP draws typically 15 uA current in backup state.

## Antenna

The SKG09D BD/GPS receiver is designed for supporting the active antenna or passive antenna connected with pin RF\_IN. The gain of active antenna should be no more than 25dB (18~20dB Typical). The maximum noise figure should be no more than 1.5dB and output impedance is at 50 Ohm.

### NOTE

With passive antenna keep the cable loss at minimum(<1dB).

## VCC\_RF

Antenna power output pin. When user wants to use external active antenna. The pin supply power for active antenna.

## UART Ports

The module supports one full duplex serial channels UART. The serial connections are at 2.85V LVTTTL logic levels, if need different voltage levels, use appropriate level shifters. the data format is however fixed: X, N, 8, 1, i.e. X baud rate, no parity, eight data bits and one stop bit, no other data formats are supported, LSB is sent first. The modules default baud rate is set up 9600bps. The RXD0 & TXD0 recommended to pull up (10KΩ). It can increase the stability of serial data.

## EXTINT

The default EXTINT function is Standby mode control but the function is not supported; leave signal floating (not connected).

## RF\_IN

The transmission line must to be control impedance from RF\_IN pin to the antenna or antenna connector of your choice. (Impedance 50Ω)

## PPS

A pulse per second (1 PPS) is an electrical signal that very precisely indicates the start of a second. Depending on the source, properly operating PPS signals have an accuracy ranging 10ns. The PPS signals are used for precise timekeeping and time measurement.

## Advanced Software Features

### Standby Mode

User can issue software command to make BD/GPS module go into standby mode that consumes less than 200uA current. BD/GPS module will be awaked when receiving any byte. The following flow chart is an example to make BD/GPS module go into standby mode and then wake up.

### Periodic Mode

When BD/GPS module is commanded to periodic mode, it will be in operation and standby periodically. Its status of power consumption is as below chart

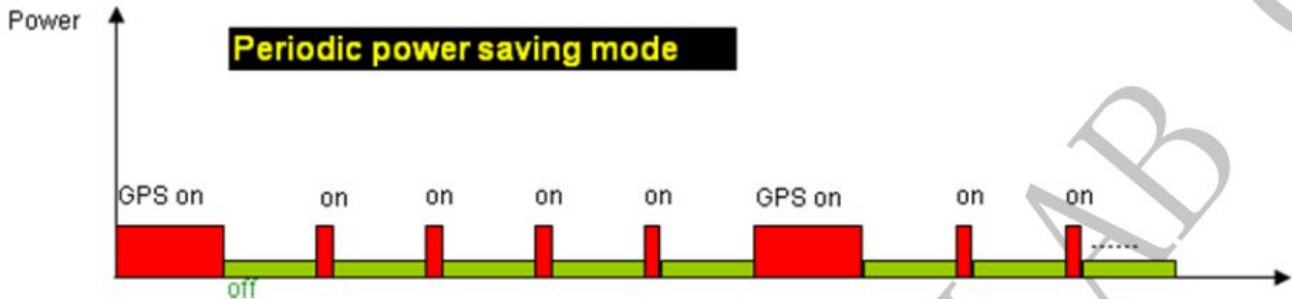

### AlwaysLocate™

AlwaysLocate™ is an intelligent controller of periodic mode. Depending on the environment and motion conditions, BD/GPS module can adaptively adjust working/standby time to achieve balance of positioning accuracy and power consumption. In this mode, the host CPU does not need to control BD/GPS module until the host CPU needs the BD/GPS position data. The following flow chart is an example to make BD/GPS module go into AlwaysLocate™ mode and then back to normal operation mode.

### AGPS Support for Fast TTFF (EPO™)

The AGPS (EPO™) supply the predicated Extended Prediction Orbit data to speed TTFF ,users can download the EPO data to GPS engine from the FTP server by internet or wireless network ,the GPS engine will use the EPO data to assist position calculation when the navigation information of satellites are not enough or weak signal zone .

### EASY™

The EASY™ is embedded assist system for quick positioning, the GPS engine will calculate and predict automatically the single emperies ( Max. up to 3 days )when power on ,and save the predict information into the memory , GPS engine will use these information for positioning if no enough information from satellites , so the function will be helpful for positioning and TTFF improvement under indoor or urban condition ,the Backup power (VBACKUP) is necessary .

### Embedded Logger function

The Embedded Logger function don't need host CPU (MCU ) and external flash to handle the operation , BD/GPS Engine will use internal flash (embedded in BD/GPS chipset ) to log the BD/GPS data (Data format : UTC, Latitude , longitude, Valid ,Checksum ), the max log days can up to 2 days under AlwaysLocate™ condition .

### AIC\_Multi-tone active interference canceller

Because different application (Wi-Fi , GSM/GPRS,3G/4G,Bluetooth )are integrated into navigation system , the harmonic of RF signal will influence the BD/GPS reception , The multi- tone active-interference canceller can reject external RF interference which come from other active components on the main board , to improve the capacity of BD/GPS reception without any needed HW change in the design .SKG09D can cancel up to 12 independent channel interference continuous wave.

## Performance Specification

Parameter	Specification	
Receiver Type	GPS L1,BD B1,GALILEO	
Sensitivity	Tracking	-162dBm Typical
	Acquisition	-145dBm Typical
Accuracy	Position	3.0m CEP50 without SA(Typical Open Sky)
	Velocity	0.1m/s without SA
	Timing (PPS)	10ns RMS
Acquisition Time	Cold Start	23s(Typical Open Sky)
	Warm Start	2-3s
	Hot Start	1s
	Re-Acquisition	<1s
Power Consumption	Tracking	30mA @3.3V Typical
	Acquisition	33mA @3.3V
Navigation Data Update Rate	Max 10Hz	Default 1Hz
Operational Limits	Altitude	Max 18,000m
	Velocity	Max 515m/s
	Acceleration	Less than 4g

## Electrical Characteristics

### Absolute Maximum Rating

Parameter	Symbol	Min	Max	Units
<b>Power Supply</b>				
Power Supply Volt.	VCC	-0.3	4.3	V
<b>Input Pins</b>				
Input voltage on any input connection	VIO	-0.3	3.6	V
Backup Battery	V_BCKP	-0.3	4.3	V
RF input power	RF_IN		10	dBm
Human Body Model ESD capability	RF_IN		2000	V
Machine Model ESD capability	RF_IN		100	V
<b>Environment</b>				
Storage Temperature	Tstg	-40	125	°C
Peak Reflow Soldering Temperature <10s	Tpeak		260	°C
Humidity			95	%

Note: Absolute maximum ratings are stress ratings only, and functional operation at the maxims is not guaranteed.

Stress beyond the limits specified in this table may affect device reliability or cause permanent damage to the device. For functional operating conditions, refer to the operating conditions tables as follow.

The SKG09D module is Electrostatic Sensitive Device (ESD) and may be damaged with ESD or spike voltage. Although it has built-in ESD protection circuitry at digital I/O, please handle with care to avoid permanent malfunction or performance degradation. Note that RFIN has no ESD protection circuits.

### Operating Conditions

Parameter	Symbol	Condition	Min	Typ	Max	Units
Power supply voltage	V <sub>cc</sub>		3	3.3	4.2	V
Backup Battery	V <sub>BCKP</sub>		2	3.3	4.2	V
Power supply voltage ripple	V <sub>cc_PP</sub>	V <sub>cc</sub> =3.3V			30	mV
Supply current, navigation	I <sub>cc</sub>	V <sub>cc</sub> =3.3V		30	35	mA
Supply current, backup state	I <sub>bckp</sub>	V <sub>cc</sub> =3.3V		15		uA
VCC_RF Antenna bias supply	VCC_RF	I <sub>ANT</sub> = 18 m A		V <sub>cc</sub>		V
Input high voltage	V <sub>IH</sub>		2		3.6	V
Input low voltage	V <sub>IL</sub>		-0.3		0.8	V
Output high voltage	V <sub>OH</sub>		2.4		3.1	V
Output low voltage	V <sub>OL</sub>		-0.3		0.4	V
Operating temperature	T <sub>opr</sub>		-40		85	°C

**Mechanical Specification**

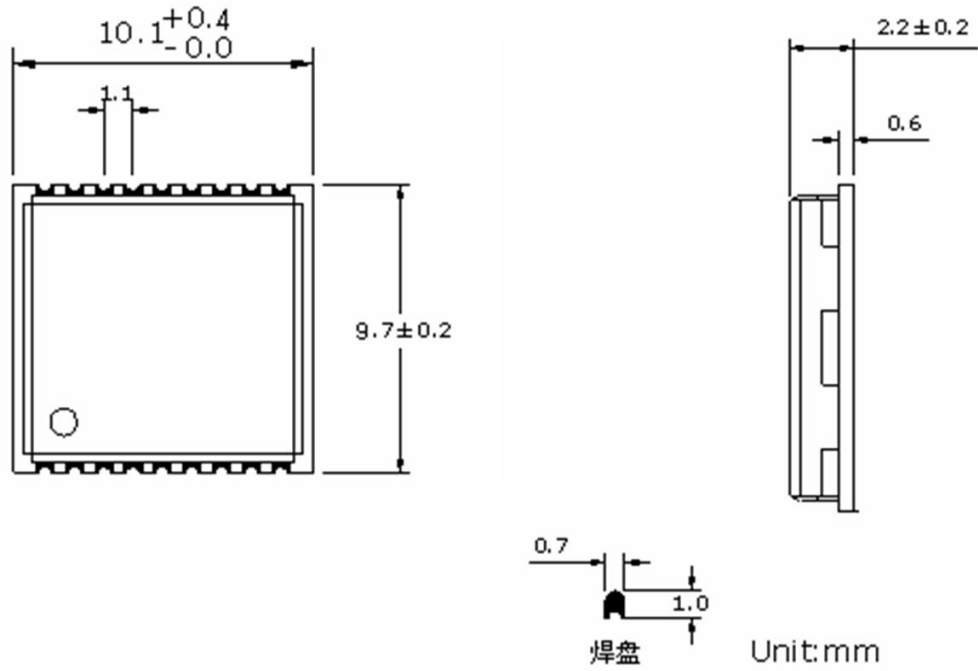

Figure 3: SKG09D Dimensions

**Recommend Layout**

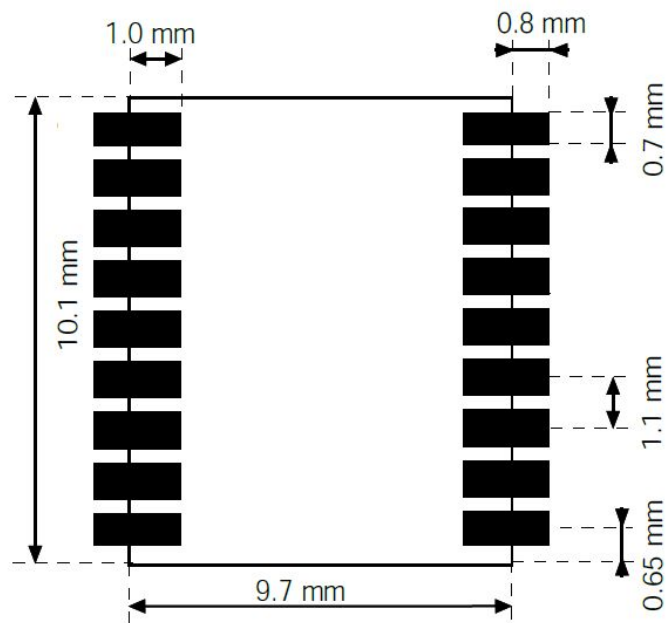
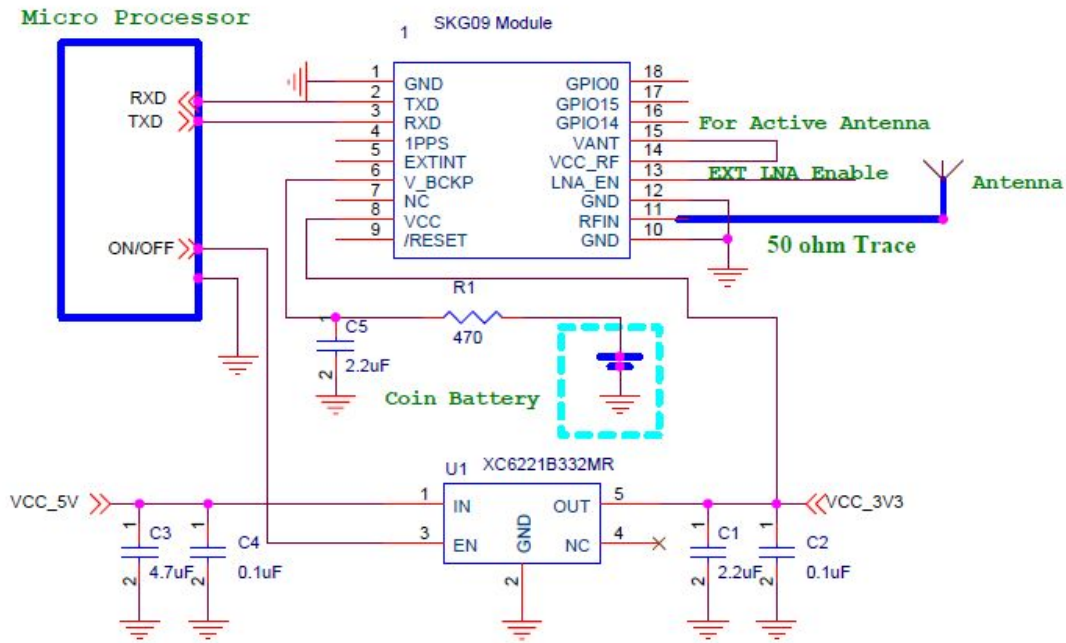

Figure 4: SKG09D Footprint



**Reference design schematic**



**Figure 5: SKG09D Typical Reference design schematic**

**Packaging Specification**

SKG09D modules are shipped in reel and with 1500 units per reel. Each tray is ‘dry’ package.

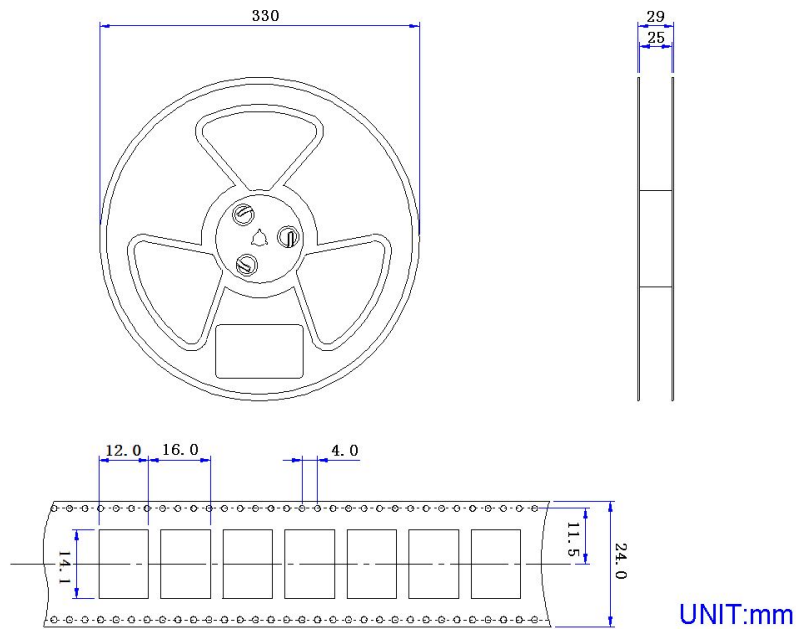

**Figure 6: SKG09D Packaging**

**Manufacturing Process Recommendations**

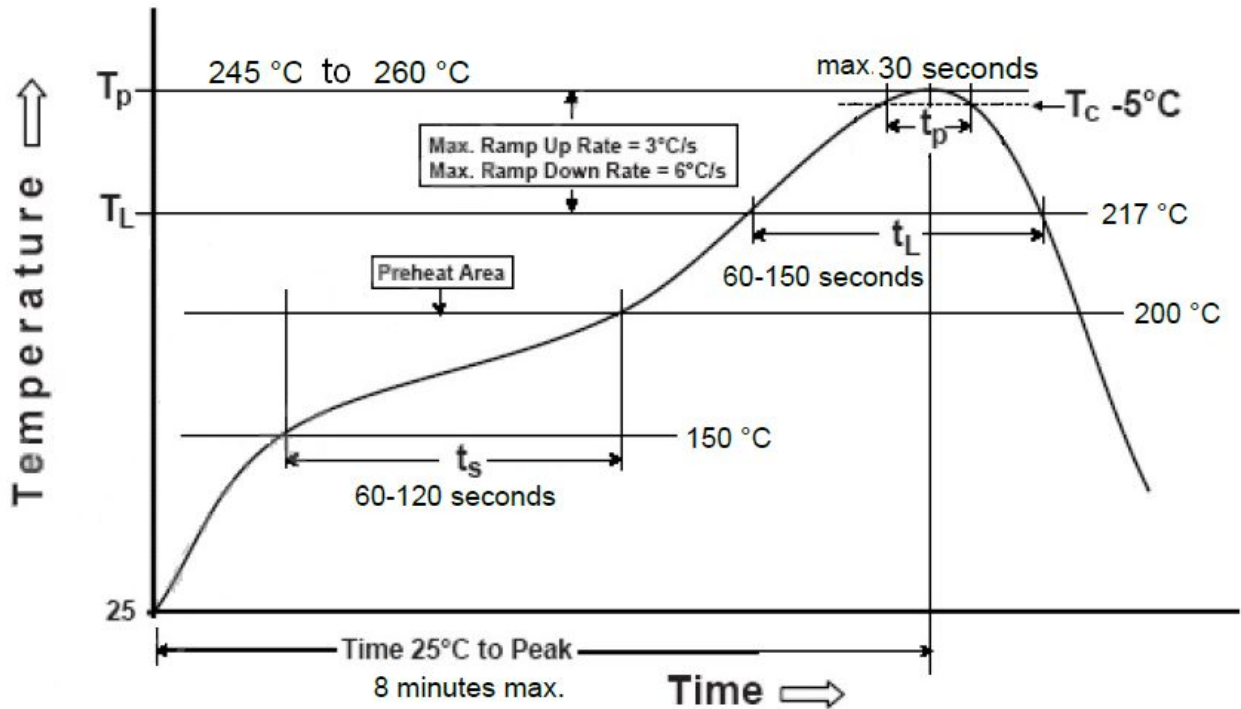

**Figure 7: SKG09D Typical Leadfree Soldering Profile**

**Note:** The final soldering temperature chosen at the factory depends on additional external factors like choice of soldering paste, size, thickness and properties of the baseboard, etc. Exceeding the maximum soldering temperature in the recommended soldering profile may permanently damage the module.

## Software Protocol

### NMEA 0183 Protocol

The NMEA protocol is an ASCII-based protocol, Records start with a \$ and with carriage return/line feed. BD/GPS specific messages all start with \$GNxxx where xxx is a three-letter identifier of the message data that follows. NMEA messages have a checksum, which allows detection of corrupted data transfers.

The Skylab SKG09D supports the following NMEA-0183 messages: GGA, GLL, GSA, GSV, RMC, VTG, ZDA. The module default NMEA-0183 output is set up GGA、GSA、RMC、GSV , and default baud rate is set up 9600bps.

Table 1: NMEA-0183 Output Messages

NMEA Record	Description	Default
GNGGA	Global positioning system fixed data	Y
GNGLL	Geographic position—latitude/longitude	N
GPGSA	GPS DOP and active satellites for GPS	Y
BDGSA	Beidou DOP and active satellites for BD	Y
GPGSV	GPS satellites in view for GPS	Y
BDGSV	Beidou satellites in view for BD	Y
GNRMC	Recommended minimum specific GNSS data	Y
GNVTG	Course over ground and ground speed	N
GNZDA	Date and Time	N

### GGA-Global Positioning System Fixed Data

This sentence contains the position, time and quality of the navigation fix.

See RMC for Fix Status, Fix Mode, Fix Date, Speed, and True Course.

See GSA for Fix Type, PDOP, and VDOP.

[\\$GNGGA,013134.000,2232.1711,N,11401.1946,E,1,9,1.17,45.2,M,-2.2,M,,\\*70](#)

Table 2: GGA Data Format

Name	Example	Units	Description
Message ID	\$GNGGA		GGA protocol header
UTC Position	013134.000		hhmmss.sss
Latitude	2232.1711		ddmm.mmmm
N/S indicator	N		N=north or S=south
Longitude	11401.1946		dddmm.mmmm
E/W Indicator	E		E=east or W=west
Position Fix Indicator	1		See Table 2-1
Satellites Used	9		Range 0 to 12
HDOP	1.17		Horizontal Dilution of Precision
MSL Altitude	45.2	meters	Altitude (referenced to the Ellipsoid)
AltUnit	M	meters	Altitude Unit

GeoSep	-2.2	meters	Geoidal Separation
GeoSepUnit	M	meters	Geoidal Separation Unit
Age of Diff.Corr.	<Null>	second	Null fields when it is not Used
Diff.Ref.Station ID	<Null>		Null fields when it is not Used
Checksum	*74		
EOL	<CR> <LF>		End of message termination

Table 2-1: Position Fix Indicators

Value	Description
0	Fix not available or invalid
1	SPS Mode, fix valid
2	Differential GPS, SPS Mode, fix valid
3	PPS Mode, fix valid

### GLL-Geographic Position – Latitude/Longitude

This sentence contains the fix latitude and longitude.

\$GNGLL,2232.1799,N,11401.1824,E,021513.000,A,A\*50

Table 3: GLL Data Format

Name	Example	Units	Description
Message ID	\$GNGLL		GLL protocol header
Latitude	2232.1799		ddmm.mmmm
N/S Indicator	N		N=north or S=south
Longitude	11401.1824		dddmm.mmmm
E/W Indicator	E		E=east or W=west
UTC Position	021513.000		hhmmss.sss
Fix Status	A		A=data valid or V=data not valid
Fix Mode	A		A=autonomous, N = No fix, D=DGPS, E=DR
Checksum	*50		
EOL	<CR> <LF>		End of message termination

### GSA-GNSS DOP and Active Satellites

This sentence contains the mode of operation, type of fix, PRNs of the satellites used in the solution as well as PDOP, HDOP and VDOP.

\$GPGSA,A,3,25,20,32,29,31,16,,,,,,,,,1.54,1.26,0.88\*13

GPS GSA message: ID1 to ID32 for GPS satellites

\$BDGSA,A,3,10,,,,,,,,,,,,,1.54,1.26,0.88\*17

BD message: ID1 to ID30 for BD satellites

Table 4: GSA Data Format

Name	Example	Units	Description
Message	\$GPGSA		GSA protocol header

Mode 1	A		See Table 4-2
Mode 2	3		See Table 4-1
ID of satellite used	28		Sv on Channel 1
ID of satellite used	20		Sv on Channel 2
...	...		...
ID of satellite used	<Null>		Sv on Channel 12 (Null fields when it is not Used)
PDOP	1.14		Position Dilution of Precision
HDOP	0.75		Horizontal Dilution of Precision
VDOP	0.85		Vertical Dilution of Precision
Checksum	*2F		
EOL	<CR> <LF>		End of message termination

Table 4-1: Mode 2

Value	Description
1	Fix not available
2	2D Fix
3	3D Fix

Table 4-2: Mode1

Value	Description
M	Manual-forced to operate in 2D or 3D mode
A	Automatic-allowed to automatically switch 2D/3D

### GSV-GNSS Satellites in View

This sentence contains the PRNs, azimuth, elevation, and signal strength of all satellites in view.

\$GPGSV,4,1,13,14,53,105,,16,46,228,27,31,46,011,28,32,39,289,23\*72

\$GPGSV,4,2,13,29,23,067,20,06,17,183,13,22,16,172,17,20,15,307,29\*70

\$GPGSV,4,3,13,27,08,188,17,25,07,039,33,03,04,197,17,33,,,\*42

\$GPGSV,4,4,13,193,,,\*40

GPS GSV message: ID1 to ID32 for GPS satellites

\$BDGSV,1,1,03,10,46,329,31,08,43,161,,09,40,217,\*52

BD GSV message: ID1 to ID30 for BD satellites

Table 5: GSV Data Format

Name	Example	Units	Description
Message ID	\$GPGSV		GSV protocol header
Number of Message	4		Total number of GSV sentences
Message Number	1		Sentence number of the total
Satellites in View	13		Number of satellites in view

Satellite ID	207		Channel 1
Elevation	79	degrees	Channel 1(Range 00 to 90)
Azinmuth	304	degrees	Channel 1(Range 000 to 359)
SNR(C/NO)	34	dB-Hz	Channel 1(Range 00 to 99, null when not tracking)
...			...
Satellite ID	210		Channel 4(Range 01 to 32)
Elevation	60	degrees	Channel 4(Range 00 to 90)
Azimuth	245	degrees	Channel 4(Range 000 to 359)
SNR(C/NO)	28	dB-Hz	Channel 4(Range 00 to 99, null when not tracking)
Checksum	*41		
EOL	<CR> <LF>		End of message termination

Depending on the number of satellites tracked multiple messages of GSV data may be required.

### RMC-Recommended Minimum Specific GNSS Data

This sentence contains the recommended minimum fix information.

See GGA for Fix Quality, Sats Used, HDOP, Altitude, Geoidal Separation, and DGPS data.

See GSA for Fix Type, PDOP and VDOP.

[\\$GNRMC,013133.000,A,2232.1711,N,11401.1946,E,0.017,0.00,040513,,,A\\*4E](#)

Table 6: RMC Data Format

Name	Example	Units	Description
Message ID	\$GNRMC		RMC protocol header
UTS Position	013133.000		hhmmss.sss
Status	A		A=data valid or V=data not valid
Latitude	2232.1711		ddmm.mmmm
N/S Indicator	N		N=north or S=south
Longitude	11401.1946		dddmm.mmmm
E/W Indicator	E		E=east or W=west
Speed Over Ground	0.017	Knots	
Course Over Ground	0.00	Degrees	True Course
Date(UTC)	040513		ddmmyy
Magnetic variation	<Null>	Degrees	Null fields when it is not Used
Magnetic Variation Direction	<Null>		E=east or W=west (Null fields when it is not Used)
Fix Mode	A		A=autonomous, N = No fix, D=DGPS, E=DR
Checksum	*6B		
EOL	<CR> <LF>		End of message termination

### VTG-Course Over Ground and Ground Speed

This sentence contains the course and speed of the navigation solution.

\$GNVTG,148.81,T,,M,0.13,N,0.24,K,A\*3D

Table 7: VTG Data Format

Name	Example	Units	Description
Message ID	\$GNVTG		VTG protocol header
Tcourse	148.81	Degrees	True Course
Reference	T		T = True
Mcourse	<Null>	Degrees	Magnetic Course (Null fields when it is not Used)
Reference	M		M = Magnetic (Null fields when it is not Used)
Speed over ground	0.13	Knots	Nautical Miles per Hour
Units	N		Knots
Speed over ground	0.24	Km/hr	in Kilometers per Hour
Units	K		Kilometer per hour
Mode	A		A=Autonomous, N=No fix, D=DGPS, E=DR
Checksum	*3D		
EOL	<CR> <LF>		End of message termination

### ZDA-Date and Time

This sentence contains UTC date & time, and local time zone offset information.

\$GNZDA,023345.000,10,04,2010,,\*50

Table 8: ZDA Data Format

Name	Example	Units	Description
Message ID	\$GNZDA		ZDA protocol header
UTC Time	023345.000		hhmmss.sss
Day	10		UTC time: day (01 ... 31) dd
Month	04		UTC time: month (01 ... 12) mm
Year	2010		UTC time: year (4 digit year) yyyy
local zone hours	<null>		Local Time Zone Offset Hours (Null fields when it is not Used)
local zone minutes	<null>		Local Time Zone Offset Minutes (Null fields when it is not Used)
Checksum	*50		
EOL	<CR> <LF>		End of message termination

**NMEA CMD List**

Table 9: NMEA CMD List

NMEA CMD TYPE	NMEA CMD Example:
Hot Restart	\$PMTK101*32<CR><LF>
Warm Restart	\$PMTK102*31<CR><LF>
Cold Restart	\$PMTK103*30<CR><LF>
Full Cold Restart	\$PMTK104*37<CR><LF>
port baudrate	\$PMTK251,38400*27<CR><LF>
MODE SET	
BD only mode	\$PMTK353,0,0,0,0,1
GPS only mode	\$PMTK353,1,0,0,0,0
GPS + BD o mixed mode	\$PMTK353,1,0,0,0,1

## Skylab M&C Technology Co., Ltd.

**Address:** 9<sup>th</sup> Floor, Zhongguang Building, Yayuan Road, Bantian, Shenzhen

**Phone:** 86-755 8340 8210 (Sales Support)

**Phone:** 86-755 8340 8130 (Technical Support)

**Fax:** 86-755-8340 8560

**E-Mail:** [sales1@skylab.com.cn](mailto:sales1@skylab.com.cn), [jasica.du@skylab.com.cn](mailto:jasica.du@skylab.com.cn)

**Website:** [www.skylab.com.cn](http://www.skylab.com.cn)