

SEMIDRIVER™

Printed Circuit Board for SKHI 21A and SKHI 22 A/B drivers

SKPC 22/2

Preliminary Data

Features

- Includes an inverter for driver error signal (capability)
- Able to connect single and paralleled IGBT modules
- Same dimensions of SKHI 10 driver
- Uses same input connector and pinouts as SKHI 23 driver
- Glass fiber epoxy (UL)
- Ready for wave soldering
- Connectors included

Remarks

- SKPC 22/2 normally should be completed by the customer, but it can be made available with parts fitted, on request
- See SKHI 21 A, 22A/B datasheet to choose components values

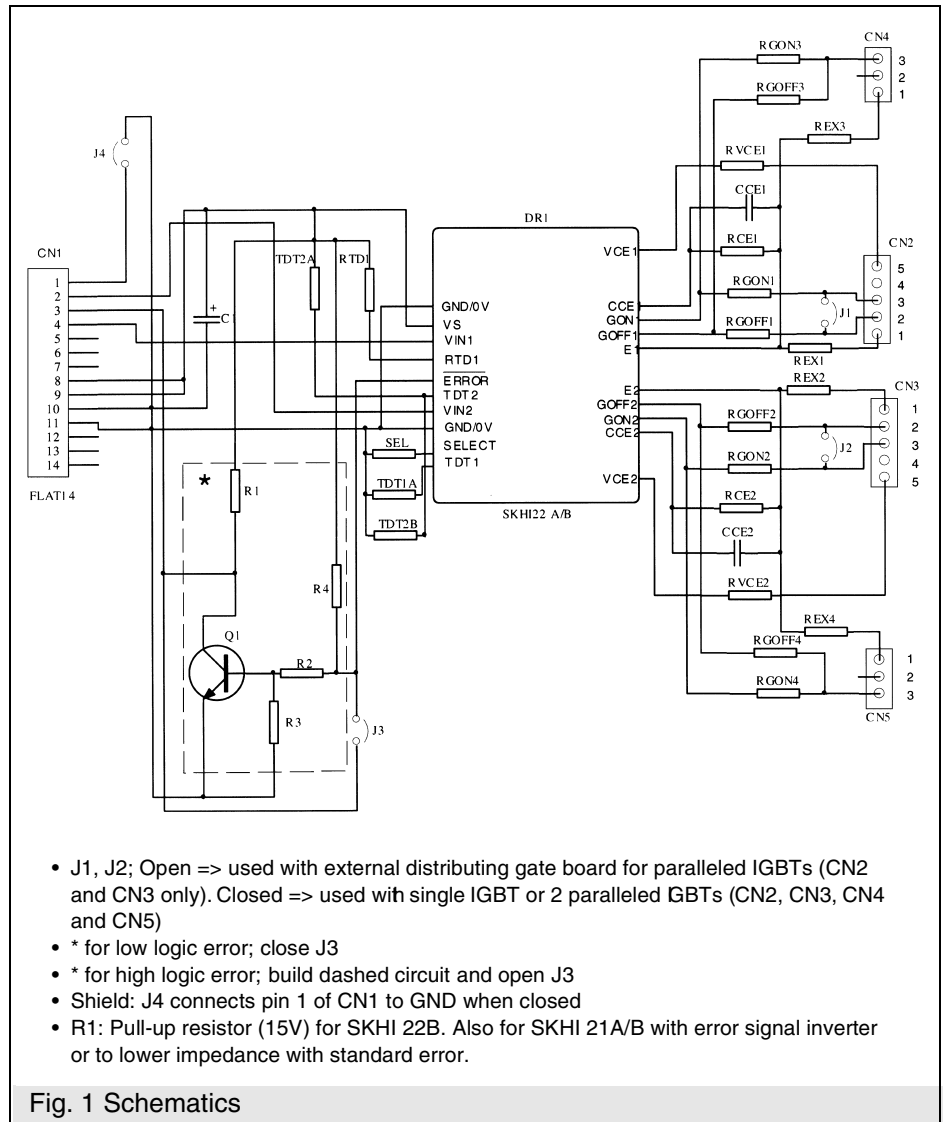

Fig. 1 Schematics

Recommended piece parts list

Part #	Function	Designation	Recommended Values ¹⁾
DR1	main driver		
C1	Vs filter	radial electrol. cap.	10...47µF / 35 V
CCE1	CceTOP	polystyrene cap.	0,33 nF > 25 V
CCE2	CceBOT	polystyrene cap	0,33 nF > 25 V
Q1	error inversion	NPN transistor	BC 547B
R1 ³⁾	error inversion	resistor 0,25W	4k7 or none (for open collector output)
R2	error inversion	resistor 0,25W	2k2
R3	error inversion	resistor 0,25W	2k2
R4	error inversion	resistor 0,25W	4k7
RGON1	RgonTOP1	resistor 0,25W	3...100 ohms (6...100 ohms with paralleled IGBTs)
RGON2	RgonBOT1	resistor 0,25W	3...100 ohms (6...100 ohms with paralleled IGBTs)
RGON3	RgonTOP2	resistor 0,25W	6...100 ohms
RGON4	RgonBOT2	resistor 0,25W	6...100 ohms
RGOFF1	RgoffTOP1	resistor 0,25W	3...100 ohms (6...100 ohms with paralleled IGBTs)
RGOFF2	RgoffBOT1	resistor 0,25W	3...100 ohms (6...100 ohms with paralleled IGBTs)
RGOFF3	RgoffTOP2	resistor 0,25W	6...100 ohms
RGOFF4	RgoffBOT2	resistor 0,25W	6...100 ohms
REX1	RexTOP1	resistor 0,25W	0 ohms (0,47 ohms with paralleled IGBTs)
REX2	RexBOT1	resistor 0,25W	0 ohms (0,47 ohms with paralleled IGBTs)
REX3	RexTOP2	resistor 0,25W	0 ohms (0,47 ohms with paralleled IGBTs)
REX4	RexBOT2	resistor 0,25W	0 ohms (0,47 ohms with paralleled IGBTs)
RVCE1	RvceTOP	resistor 0,25W	0 ohms (1k ohms with 1700V IGBTs)
RVCE2	RvceBOT	resistor 0,25W	0 ohms (1k ohms with 1700V IGBTs)
RTD1	Rtd to Vs	resistor 0,25W	open (0 ohms with legacy SKHI 21 and 22 drivers)
TDT1A	TDT1 to GND	wire jumper	open (used only with SKHI 22B)
TDT2A	Rtd / TDT2 to Vs	resistor 0,25W	open (0 ohms with legacy SKHI 21 and 22 drivers)
TDT2B	TDT2 to GND	wire jumper	open (used only with SKHI 22B)
SEL	SEL to GND	wire jumper	open (used only with SKHI 22B)
J1	external // IGBTs	wire jumper	closed (open for 2 cables to gates)
J2	external // IGBTs	wire jumper	closed (open for 2 cables to gates)
J3	error inversion	wire jumper	closed (open for error inversion)
J4	shield	wire jumper	open
CN1	input	14 pin flat cable	input connector
CN2	Top main output	Molex 41791 - 5 pos.	top IGBT output ²⁾
CN3	Bot main output	Molex 41791 - 5 pos.	bot IGBT output ²⁾
CN4	Top sec. output	Molex 41791 - 3 pos.	top IGBT output (paralleled) ²⁾
CN5	Bot sec. output	Molex 41791 - 3 pos.	bot IGBT output (paralleled) ²⁾

¹⁾ See datasheet SKHI 22 A/B

²⁾ Matches with Molex 41695 crimp housing

³⁾ Can be used as ull-up resistor even without error inversion

Obs.: Q1, R1, R2, R3 and R4 - assembled when error inversion is used

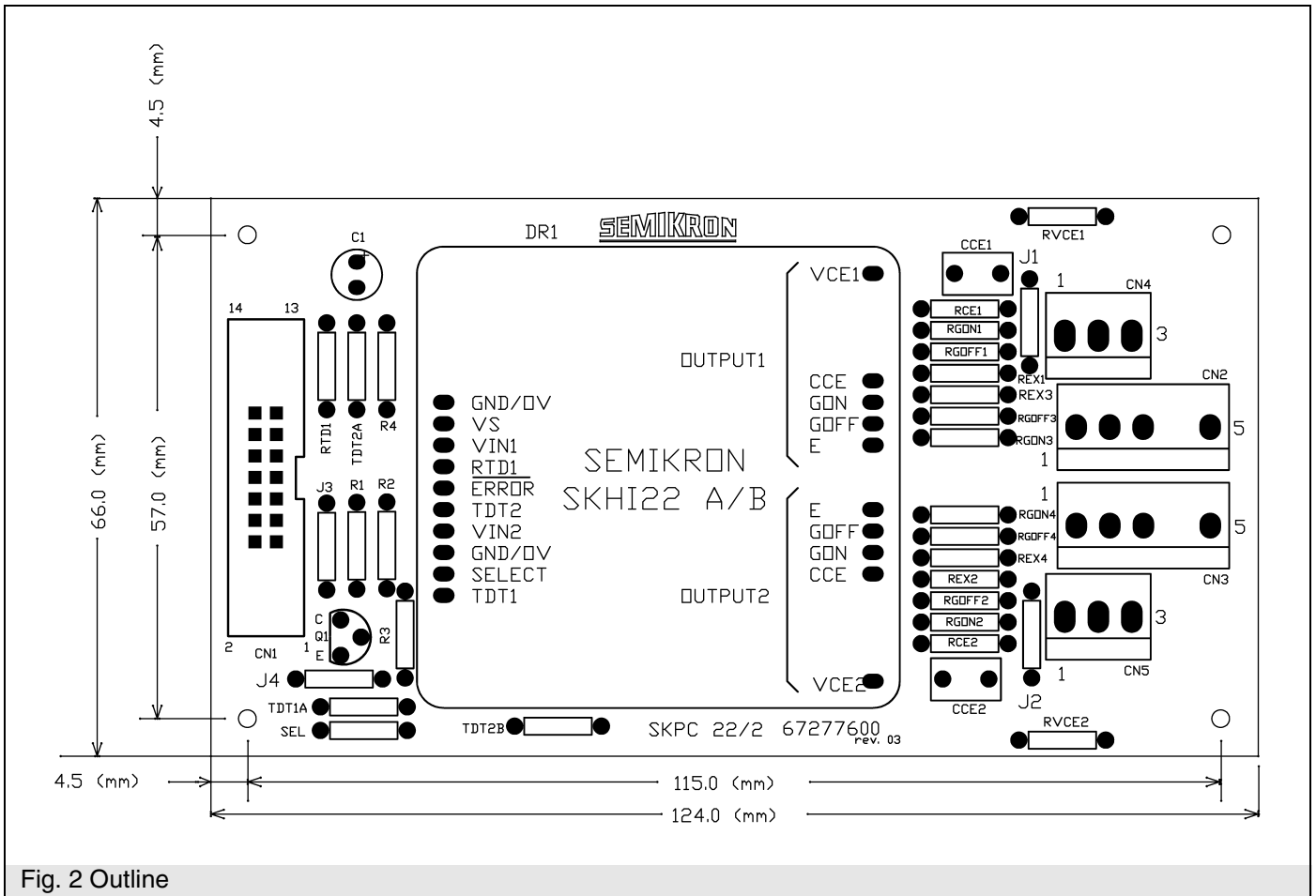

Fig. 2 Outline