

DATA SHEET

SKY12332-310LF: 6-Bit Digital Attenuator with Driver

LF–1 GHz, 0.5 dB LSB, 31.5 dB Range

Features

- Attenuation range: 31.5 dB
- LSB: 0.5 dB
- On-board low noise CMOS driver
- Excellent RF noise floor
- Single 5 V supply
- Very low DC power consumption
- Single positive control for each bit
- Small 5 x 5 mm QFN-32 package
- Available lead (Pb)-free and RoHS-compliant MSL-1 @ 260 °C per JEDEC J-STD-020

Description

The Skyworks SKY12332-310LF is 6-bit digital GaAs attenuator with an on-board low-noise CMOS driver. This attenuator offers excellent performance from low frequency through 1 GHz, making it ideal for IF and RF level control applications. It contains an on-board CMOS driver circuit which accepts CMOS logic levels at the 6 control inputs and produces a negative supply voltage to control the GaAs attenuator.

The SKY12332-310LF has excellent linearity for compatibility with non-constant envelope signals, such as W-CDMA and OFDM. The 6 attenuation bits are binary weighted, with an LSB of 0.5 dB and a total nominal attenuation range of 31.5 dB. It also has excellent attenuation accuracy and is monotonic. The low-noise CMOS driver enables a very low RF noise floor, typically -100 dBm.

Typical applications for this attenuator include level control in cellular base stations, wireless data transceivers, broadband systems, etc.

The required supply voltage for SKY12332-310LF is 5V. This part can operate over the temperature range of -40 °C to 85 °C.

An evaluation board is available upon request.

NEW Skyworks offers lead (Pb)-free, RoHS (Restriction of Hazardous Substances)-compliant packaging.



Functional Block Diagram

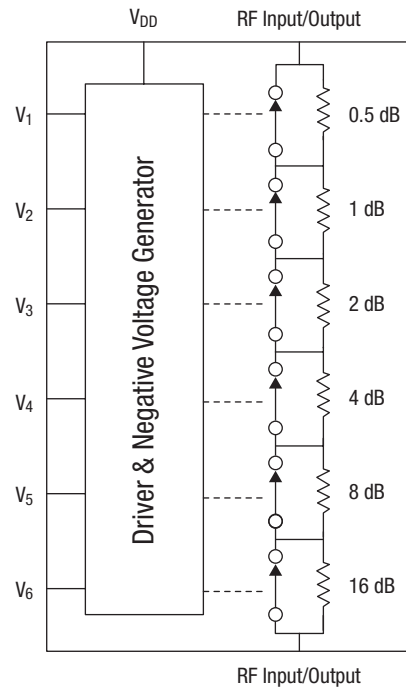

Electrical Specifications

V_{DD} = 5 V, T = 25 °C, Z₀ = 50 Ω, unless otherwise noted

Parameter	Symbol	Condition	Frequency	Min.	Typ.	Max.	Unit
Insertion loss	IL		LF–500 MHz		1.5	1.8	dB
			LF–1.0 GHz		1.8	2.2	dB
Attenuation range					31.5		dB
Attenuation accuracy		Attenuation referred to insertion loss	LF–500 MHz LF–1.0 GHz	± (0.20 + 2% of attenuation setting in dB) ± (0.25 + 3% of attenuation setting in dB)			
RF input/RF output VSWR		Non-driven port terminated in Z ₀	LF–1.0 GHz		1.4:1	1.6:1	
Control voltage	V _{CTL}	V _{CTL} = V _{LOW} V _{CTL} = V _{HIGH}		0		0.8	V
				2.7		V _{DD}	V
Control port current	I _{CTL}	V _{CTL} = V _{LOW} V _{CTL} = V _{HIGH}			20		μA
					20		μA
Switching characteristics							
Rise, fall time	t _r , t _f	10%/90% or 90%/10% of RF			30		ns
On, off time	t _{on} , t _{off}	50% V _{CTL} to 90%/10% of RF			50		ns
Video feedthrough		T _{RISE} = 1 ns, BW = 500 MHz			50		mV
Input power for 1 dB compression	IP ₁ dB		50 MHz		22		dBm
			500 MHz–1.0 GHz		29		dBm
Input third order intermodulation intercept point	IIP3	2 input tones, 5 dBm each tone	50 MHz		36		dBm
			500 MHz–1.0 GHz		48		dBm
DC supply voltage	V _{DD}			4.75	5	5.25	V
DC supply current	I _{DD}				700		μA

Typical Performance Data

$V_{DD} = 5\text{ V}$, $T = 25\text{ }^\circ\text{C}$, $Z_0 = 50\ \Omega$, unless otherwise noted

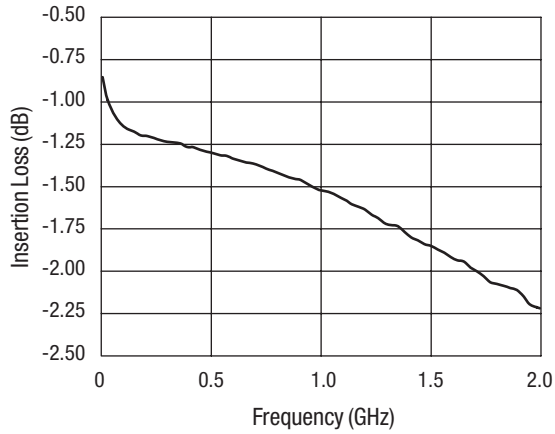

Insertion Loss vs. Frequency

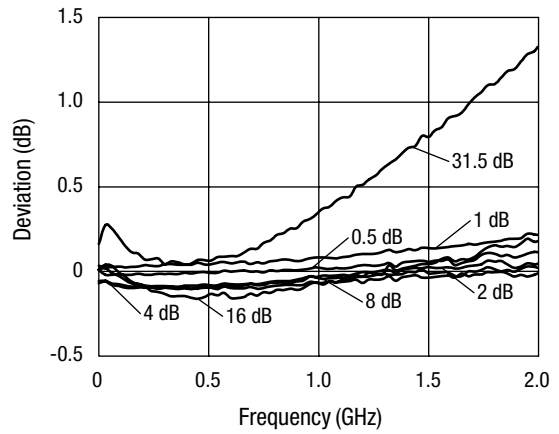

Attenuation Accuracy vs. Frequency

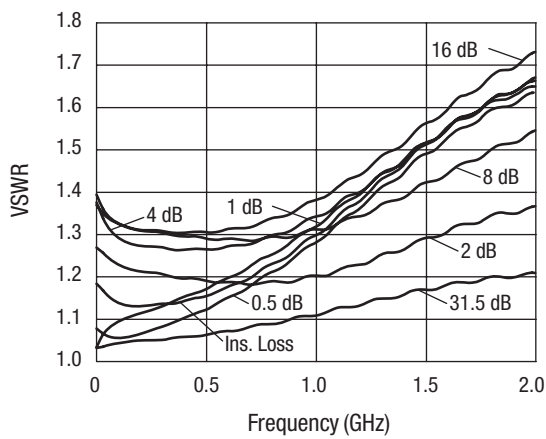

Input VSWR vs. Frequency

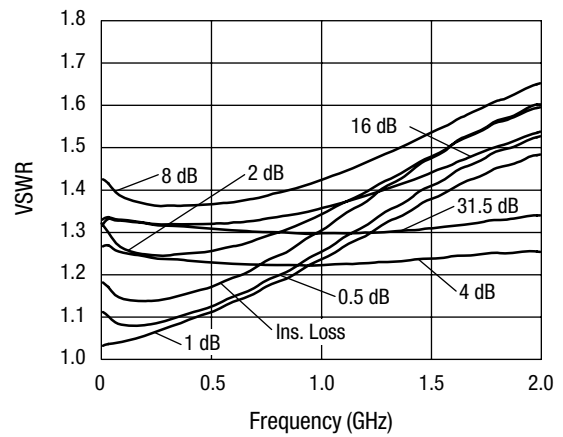

Output VSWR vs. Frequency

Absolute Maximum Ratings

Characteristic	Value
RF input power	2 W for $f > 500$ MHz 0.5 W for $50 \text{ MHz} \leq f \leq 500 \text{ MHz}$
Supply voltage	6 V
Supply current	2 mA
Operating temperature	-40 °C to +85 °C
Storage temperature	-65 °C to +150 °C

Performance is guaranteed only under the conditions listed in the specifications table and is not guaranteed under the full range(s) described by the Absolute Maximum specifications. Exceeding any of the absolute maximum/minimum specifications may result in permanent damage to the device and will void the warranty.

CAUTION: Although this device is designed to be as robust as possible, ESD (Electrostatic Discharge) can damage this device. This device must be protected at all times from ESD. Static charges may easily produce potentials of several kilovolts on the human body or equipment, which can discharge without detection. Industry-standard ESD precautions must be employed at all times.

Truth Table

V ₆	V ₅	V ₄	V ₃	V ₂	V ₁	Attenuation J ₁ -J ₂
16 dB	8 dB	4 dB	2 dB	1 dB	0.5 dB	
0	0	0	0	0	0	Ins. loss
0	0	0	0	0	1	0.5 dB
0	0	0	0	1	0	1 dB
0	0	0	1	0	0	2 dB
0	0	1	0	0	0	4 dB
0	1	0	0	0	0	8 dB
1	0	0	0	0	0	16 dB
1	1	1	1	1	1	31.5 dB

"0" = V_{LOW}
"1" = V_{HIGH}

Pin Out

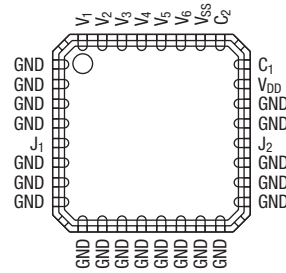

Pin Description

Pin	Symbol	Function
1-4, 6-19, 21-23	GND	Connect to system ground via lowest possible impedance
5	J ₁	RF input/output
20	J ₂	RF output/input
23	V _{DD}	Positive supply voltage input. Bypass this pin to ground via a 10 nF or larger capacitor
24, 25	C ₁ , C ₂	Connect charge pump capacitor, 25 nF typical, between these pins
26	V _{SS}	Negative supply voltage filter capacitor. Bypass this pin to ground via a 10 nF or larger capacitor.
27	V ₆	Control voltage input for 16 dB bit, MSB
28	V ₅	Control voltage input for 8 dB bit
29	V ₄	Control voltage input for 4 dB bit
30	V ₃	Control voltage input for 2 dB bit
31	V ₂	Control voltage input for 1 dB bit
32	V ₁	Control voltage input for 0.5 dB bit, LSB
Paddle		Connect to system ground via lowest possible electrical and thermal impedance

Circuit Description

The SKY12332-301LF is comprised of a Si CMOS die and a GaAs digital attenuator die, packaged in a 5 x 5 mm, 32-pin QFN surface mount package.

The CMOS die performs the following functions: it contains a charge pump circuit that generates a negative voltage, V_{SS} , from the positive supply voltage, V_{DD} ; it decodes the 6-bit control word applied to ports V_1 through V_6 ; and, it drives the corresponding switching FETs on the GaAs attenuator die. This circuit was optimized to produce the lowest possible noise in the RF signal path.

The GaAs attenuator die is comprised of 6 resistive, fixed attenuator sections with nominal input and output impedance of 50 Ω . The attenuation of these sections is binary weighted, ranging from 0.5 dB nominal up to 16 dB nominal. These attenuator sections are either switched into or out of the main signal path, between ports J_1 and J_2 , according to the 6-bit control word applied to ports V_1 through V_6 . This die is also utilized in AA113-310.

The switching is performed by depletion mode MESFETs on the attenuator die. The charge pump circuit on the CMOS die generates the negative voltage V_{SS} , nominally -3.75 V, required to enable reverse bias of the gate-source of the MESFETs that must be switched to high drain-source impedance to properly select or bypass the fixed resistive attenuator sections.

Recommended Solder Reflow Profiles

Refer to the [“Recommended Solder Reflow Profile”](#) Application Note.

Tape and Reel Information

Refer to the [“Discrete Devices and IC Switch/Attenuators Tape and Reel Package Orientation”](#) Application Note.

Suggested Circuit

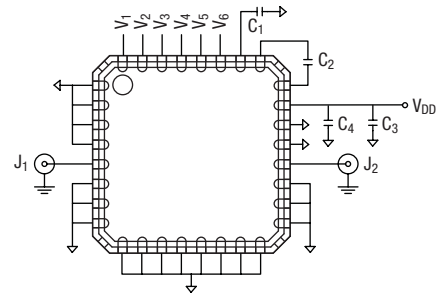

Component	Suggested Value
C_1, C_3	0.01 μF
C_2	0.025 μF
C_4	100 pF

QFN 5 x 5 (-310)

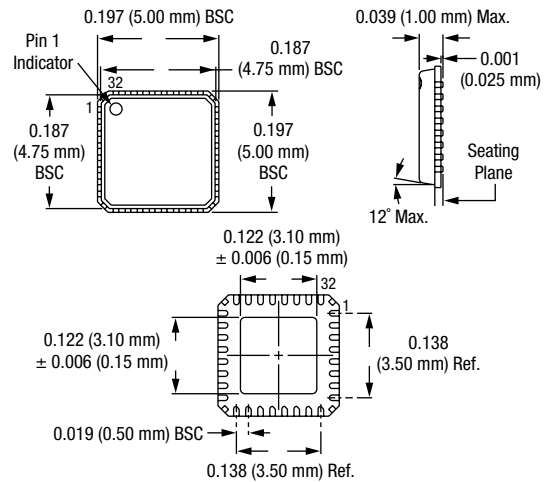

Copyright © 2002, 2003, 2004, 2005, 2006, 2007, Skyworks Solutions, Inc. All Rights Reserved.

Information in this document is provided in connection with Skyworks Solutions, Inc. ("Skyworks") products or services. These materials, including the information contained herein, are provided by Skyworks as a service to its customers and may be used for informational purposes only by the customer. Skyworks assumes no responsibility for errors or omissions in these materials or the information contained herein. Skyworks may change its documentation, products, services, specifications or product descriptions at any time, without notice. Skyworks makes no commitment to update the materials or information and shall have no responsibility whatsoever for conflicts, incompatibilities, or other difficulties arising from any future changes.

No license, whether express, implied, by estoppel or otherwise, is granted to any intellectual property rights by this document. Skyworks assumes no liability for any materials, products or information provided hereunder, including the sale, distribution, reproduction or use of Skyworks products, information or materials, except as may be provided in Skyworks Terms and Conditions of Sale.

THE MATERIALS, PRODUCTS AND INFORMATION ARE PROVIDED "AS IS" WITHOUT WARRANTY OF ANY KIND, WHETHER EXPRESS, IMPLIED, STATUTORY, OR OTHERWISE, INCLUDING FITNESS FOR A PARTICULAR PURPOSE OR USE, MERCHANTABILITY, PERFORMANCE, QUALITY OR NON-INFRINGEMENT OF ANY INTELLECTUAL PROPERTY RIGHT; ALL SUCH WARRANTIES ARE HEREBY EXPRESSLY DISCLAIMED. SKYWORKS DOES NOT WARRANT THE ACCURACY OR COMPLETENESS OF THE INFORMATION, TEXT, GRAPHICS OR OTHER ITEMS CONTAINED WITHIN THESE MATERIALS. SKYWORKS SHALL NOT BE LIABLE FOR ANY DAMAGES, INCLUDING BUT NOT LIMITED TO ANY SPECIAL, INDIRECT, INCIDENTAL, STATUTORY, OR CONSEQUENTIAL DAMAGES, INCLUDING WITHOUT LIMITATION, LOST REVENUES OR LOST PROFITS THAT MAY RESULT FROM THE USE OF THE MATERIALS OR INFORMATION, WHETHER OR NOT THE RECIPIENT OF MATERIALS HAS BEEN ADVISED OF THE POSSIBILITY OF SUCH DAMAGE.

Skyworks products are not intended for use in medical, lifesaving or life-sustaining applications, or other equipment in which the failure of the Skyworks products could lead to personal injury, death, physical or environmental damage. Skyworks customers using or selling Skyworks products for use in such applications do so at their own risk and agree to fully indemnify Skyworks for any damages resulting from such improper use or sale.

Customers are responsible for their products and applications using Skyworks products, which may deviate from published specifications as a result of design defects, errors, or operation of products outside of published parameters or design specifications. Customers should include design and operating safeguards to minimize these and other risks. Skyworks assumes no liability for applications assistance, customer product design, or damage to any equipment resulting from the use of Skyworks products outside of stated published specifications or parameters.

Skyworks, the Skyworks symbol, and "Breakthrough Simplicity" are trademarks or registered trademarks of Skyworks Solutions, Inc., in the United States and other countries. Third-party brands and names are for identification purposes only, and are the property of their respective owners. Additional information, including relevant terms and conditions, posted at www.skyworksinc.com, are incorporated by reference.