

**PRELIMINARY DATA SHEET**

# SKY13441: 0.4-2.7 GHz SP10T Switch with GPIO Interface

## Applications

- 2G/3G multimode cellular handsets (UMTS, CDMA2000, EDGE, GSM)
- Embedded data cards

## Features

- Broadband frequency range: 0.4 to 2.7 GHz
- Single, positive DC power supply (2.5 to 3.3 V)
- Excellent Band 13 2<sup>nd</sup> harmonic rejection
- Integrated, low-pass harmonic filter for GSM transmit paths
- Integrated GPIO interface
- Any of eight TRX ports can be used for WCDMA transmit/receive or GSM receive functions
- Small MCM (20-pin, 3.2 x 2.5 mm) package (MSL3, 260 °C per JEDEC J-STD-020)



Skyworks Green™ products are compliant with all applicable legislation and are halogen-free. For additional information, refer to *Skyworks Definition of Green™*, document number SQ04-0074.

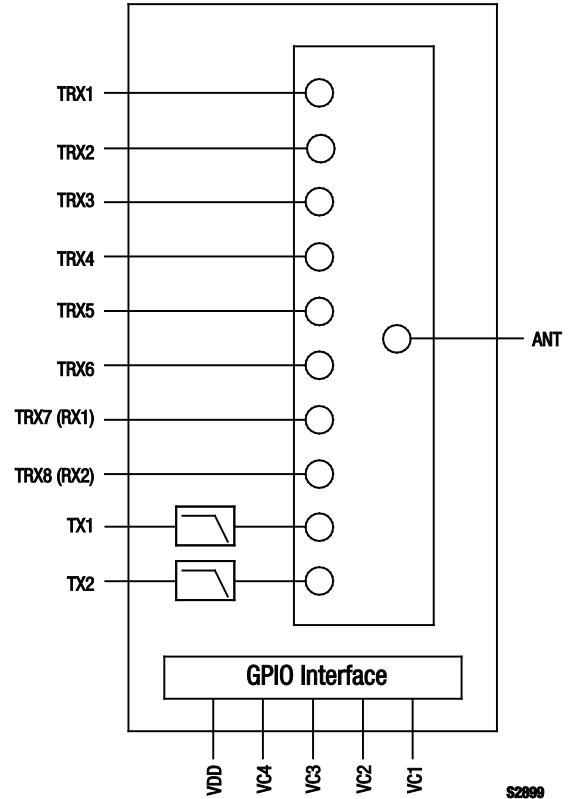

**Figure 1. SKY13441 Block Diagram**

## Description

The SKY13441 is a Single Pole, Ten-Throw (SP10T) antenna switch with an integrated General Purpose Input/Output (GPIO) interface and dual low-pass harmonic filters. The switch has eight transmit/receive ports, any of which can be used for WCDMA transmit/receive or GSM receive functions.

Using advance switching technologies, the SKY13441 maintains low insertion loss and high isolation for both transmit and receive switching paths. The switch also exhibits an excellent triple beat ratio and 2<sup>nd</sup>/3<sup>rd</sup> order modulation distortion performance.

Switching is controlled by an integrated GPIO interface. Depending on the logic applied to the decoder, the antenna pin is connected to one of ten switched RF ports using a low insertion loss path, while the paths between the antenna pin and the other RF pins are in a high isolation state. No external DC blocking capacitors are required on the RF paths.

The SKY13441 is manufactured in a compact, 3.2 x 2.5 mm, 20-pin Multi-Chip Module (MCM) package.

A functional block diagram is shown in Figure 1. The pin configuration and package are shown in Figure 2. Signal pin assignments and functional pin descriptions are provided in Table 1.

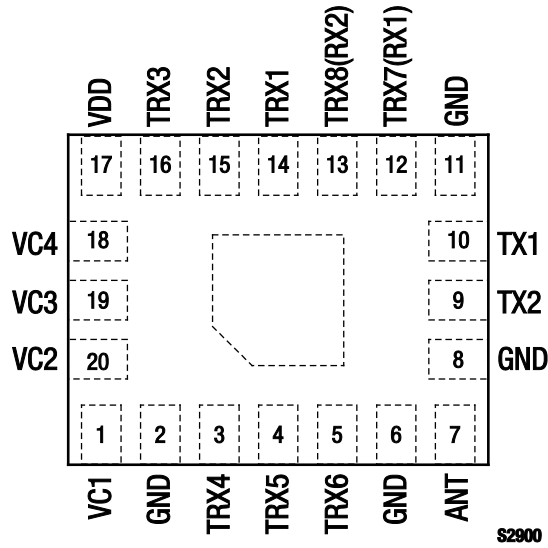

Figure 2. SKY13441 Pinout – 20-Pin MCM (Top View)

Table 1. SKY13441 Signal Descriptions

Pin #	Name	Description	Pin #	Name	Description
1	VC1	DC input control voltage 1	11	GND	Ground
2	GND	Ground	12	TRX7(RX1)	RF input/output port 7
3	TRX4	RF input/output port 4	13	TRX8(RX2)	RF input/output port 8
4	TRX5	RF input/output port 5	14	TRX1	RF input/output port 1
5	TRX6	RF input/output port 6	15	TRX2	RF input/output port 2
6	GND	Ground	16	TRX3	RF input/output port 3
7	ANT	Antenna RF port	17	VDD	DC power supply
8	GND	Ground	18	VC4	DC input control voltage 4
9	TX2	GSM high band transmit RF input port with integrated harmonic filter	19	VC3	DC input control voltage 3
10	TX1	GSM low band transmit RF input port with integrated harmonic filter	20	VC2	DC input control voltage 2

Note: Bottom ground paddles must be connected to ground.

**Table 2. SKY13441 Absolute Maximum Ratings**

Parameter	Symbol	Minimum	Maximum	Units
RF input power	P <sub>IN</sub>		+36	dBm
Power supply			5	V
DC control voltage	V <sub>CTRL</sub>		2.7	V
Storage temperature	T <sub>STG</sub>	-40	+125	°C
Operating temperature	T <sub>OP</sub>	-30	+90	°C

**Note:** Exposure to maximum rating conditions for extended periods may reduce device reliability. There is no damage to device with only one parameter set at the limit and all other parameters set at or below their nominal value. Exceeding any of the limits listed here may result in permanent damage to the device.

---

**CAUTION:** Although this device is designed to be as robust as possible, Electrostatic Discharge (ESD) can damage this device. This device must be protected at all times from ESD. Static charges may easily produce potentials of several kilovolts on the human body or equipment, which can discharge without detection. Industry-standard ESD precautions should be used at all times.

---

**Electrical and Mechanical Specifications**

The absolute maximum ratings of the SKY13441 are provided in Table 2. Electrical specifications are provided in Table 3. Table 4 provides the control logic for the SKY13441.

Typical performance characteristics of the SKY13441 are illustrated in Figures 3 to 13.

Figure 14 illustrates the test setup used to measure data for Figure 11. This industry standardized test is used to simulate the WCDMA Band 1 linearity of the antenna switch. A +20 dBm

Continuous Wave (CW) signal, f<sub>FUND</sub>, is sequentially applied to the TRX1 through TRX8 ports, while a -15 dBm CW blocker signal, f<sub>BLK</sub>, is applied to the ANT port.

The resulting 3<sup>rd</sup> Order Intermodulation Distortion (IMD3), f<sub>RX</sub>, is measured over all phases of f<sub>FUND</sub>. The SKY13441 exhibits exceptional performance for all TRX ports.

**Table 3. SKY13441 Electrical Specifications (Note 1) (1 of 2)**

(V<sub>DD</sub> = 2.85 V, VC1 = VC2 = VC3 = VC4 = 0/1.8 V, T<sub>OP</sub> = +25 °C, P<sub>IN</sub> = 0 dBm, Characteristic Impedance [Z<sub>0</sub>] = 50 Ω, Unless Otherwise Noted)

Parameter	Symbol	Test Condition	Min	Typical	Max	Units
<b>RF Specifications</b>						
Insertion loss: ANT to TRX1 through TRX8 ports	IL	824 to 960 MHz		0.5	0.7	dB
		1710 to 2170 MHz		0.6	0.8	dB
		2300 to 2690 MHz		0.9	1.1	dB
Insertion loss: ANT to TX1 port	IL	824 to 915 MHz		1.35	1.55	dB
Insertion loss: ANT to TX2 port	IL	1710 to 1910 MHz		1.2	1.4	dB
Isolation (TRX1/2/3/7/8 to TRX4/5/6 ports)	ISO	824 to 1910 MHz	40	45		dB
Isolation (TX1 to TRX1 through TRX8 ports)	ISO	824 to 915 MHz	40	44		dB
Isolation (TX2 to TRX1 through TRX8 ports)	ISO	1710 to 1910 MHz	32	39		dB
Isolation (TRX4 to TRX6 port)	ISO	824 to 1910 MHz	28	31		dB
Band XIII 2 <sup>nd</sup> harmonic	B13 2fo	P <sub>IN</sub> = +25 dBm, f = 787 MHz, TRX1 to TRX8		-85		dBm
Harmonics		UMTS, P <sub>IN</sub> = +27 dBm: TX1 port, P <sub>IN</sub> = +35 dBm		-48	-36	dBm
		TX2 port, P <sub>IN</sub> = +33 dBm		-45	-36	dBm
				-44	-36	dBm
Attenuation (TX1 port)		GSM850: 2f	25	28		dB
		3f	25	28		dB
		>4f		20		dB
		EGSM900: 2f	25	28		dB
		3f	22	25		dB
		>4f		20		dB
Attenuation (TX2 port)		DCS1800: 2f	25	28		dB
		3f	25	28		dB
		>4f		20		dB
		PCS1900: 2f	25	28		dB
		3f	25	28		dB
		>4f		20		dB
Return loss	IS11I	0.4 to 2.2 GHz	14	18		dB
2nd Order Input Intercept Point	IIP2	AWS, PCS, IMT to CDMA2000 modes	+95.5			dBm
2nd Order Intermodulation Distortion	IMD2	UMTS mode			-105	dBm
3rd Order Intermodulation Distortion	IMD3	UMTS mode		-110		dBm

**Table 3. SKY13441 Electrical Specifications (Note 1) (2 of 2)****( $V_{DD} = 2.85$  V,  $VC1 = VC2 = VC3 = VC4 = 0/1.8$  V,  $T_{OP} = +25$  °C,  $P_{IN} = 0$  dBm, Characteristic Impedance [ $Z_0$ ] = 50  $\Omega$ , Unless Otherwise Noted)**

Parameter	Symbol	Test Condition	Min	Typical	Max	Units
<b>RF Specifications (continued)</b>						
Triple Beat Ratio	TBR	650 to 900 MHz	81			dBc
		1710 to 2155 MHz	81			dBc
1 dB Input Compression Point	IP1dB	TX1 port, 824 to 915 MHz	+40			dBm
		TX2 port, 1710 to 1910 MHz	+39			dBm
Switching speed		10/90% RF		3	5	$\mu$ s
<b>DC Specifications</b>						
Supply voltage	$V_{DD}$		2.50	2.85	3.30	V
Supply current	$I_{DD}$			50	100	$\mu$ A
Control voltage: High Low	VC1, VC2, VC3, VC4		1.35	1.80	2.50	V
			0		0.45	V
Control current: High Low					10	$\mu$ A
				5		$\mu$ A

**Note 1:** Performance is guaranteed only under the conditions listed in this Table.**Table 4. SKY13441 Mode Control Logic**

Insertion Loss State	VC1 (Pin 1)	VC2 (Pin 20)	VC3 (Pin 19)	VC4 (Pin 18)
Standby (all ports in isolation state)	0	0	0	0
ANT to TX1	1	1	0	0
ANT to TX2	1	0	0	0
ANT to TRX8	0	1	1	0
ANT to TRX7	0	1	0	0
ANT to TRX1	0	0	1	0
ANT to TRX2	1	0	1	0
ANT to TRX3	1	1	1	0
ANT to TRX4	1	0	1	1
ANT to TRX5	1	1	1	1
ANT to TRX6	1	0	0	1

### Typical Performance Characteristics

( $V_{DD} = 2.85\text{ V}$ ,  $VC1 = VC2 = VC3 = VC4 = 0/1.8\text{ V}$ ,  $T_{OP} = +25\text{ }^{\circ}\text{C}$ ,  $P_{IN} = 0\text{ dBm}$ , Characteristic Impedance [ $Z_0$ ] =  $50\text{ }\Omega$ , Unless Otherwise Noted)

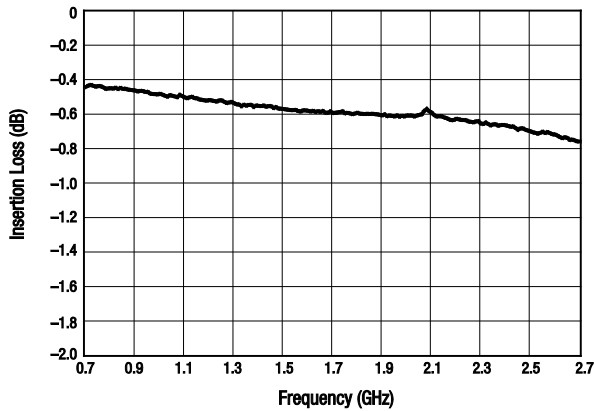

**Figure 3. Insertion Loss vs Frequency (ANT to All TRX Ports)**

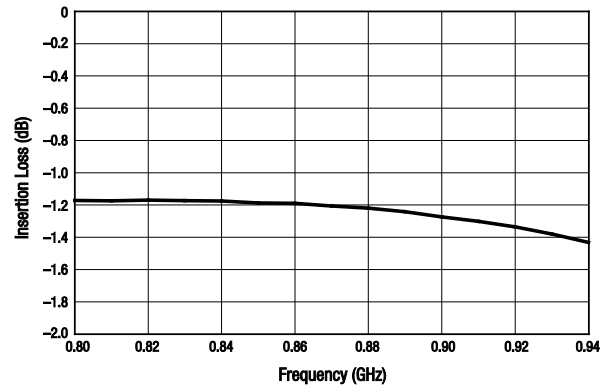

**Figure 4. Insertion Loss vs Frequency (ANT to TX1 Port)**

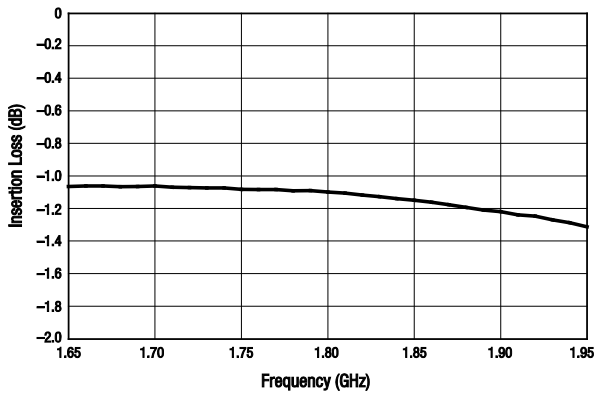

**Figure 5. Insertion Loss vs Frequency (ANT to TX2 Port)**

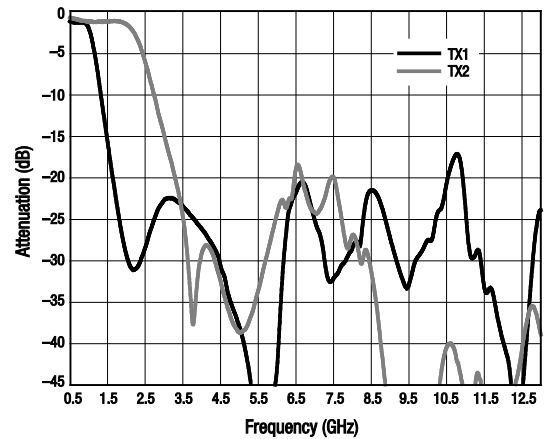

**Figure 6. Attenuation vs Frequency (ANT to TX1/2 Ports)**

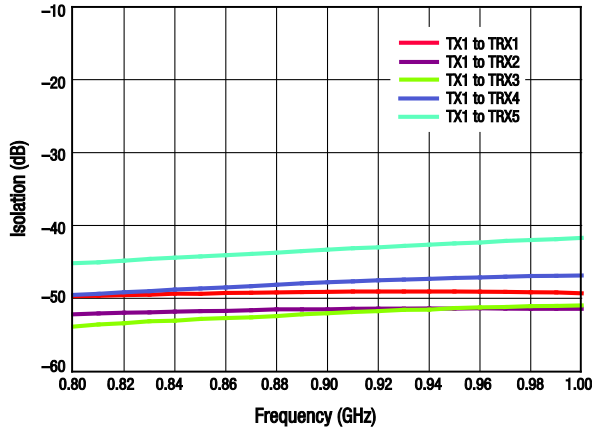

Figure 7. Isolation vs Frequency (TX1 to TRX Ports)

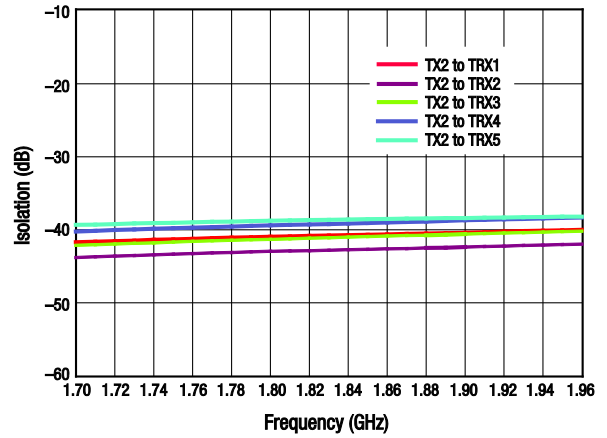

Figure 8. Isolation vs Frequency (GSM\_TX\_HB to TRX Ports)

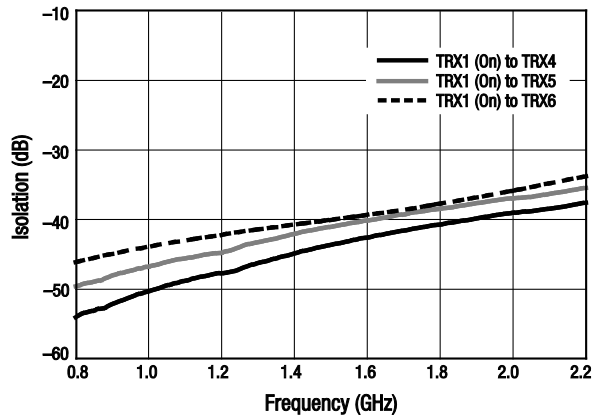

Figure 9. Isolation vs Frequency (TRX1 to TRX4/5/6 Ports)

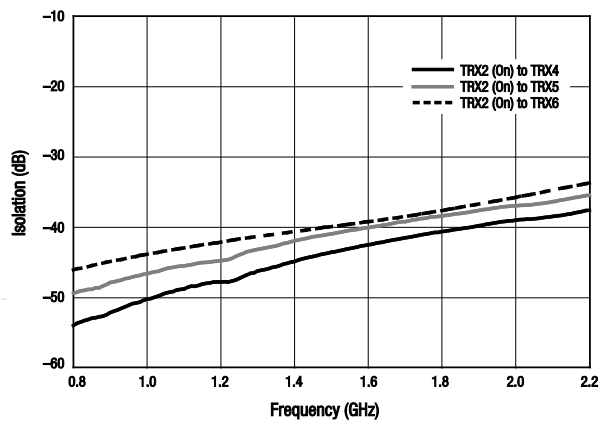

Figure 10. Isolation vs Frequency (TRX2 to TRX4/5/6 Ports)

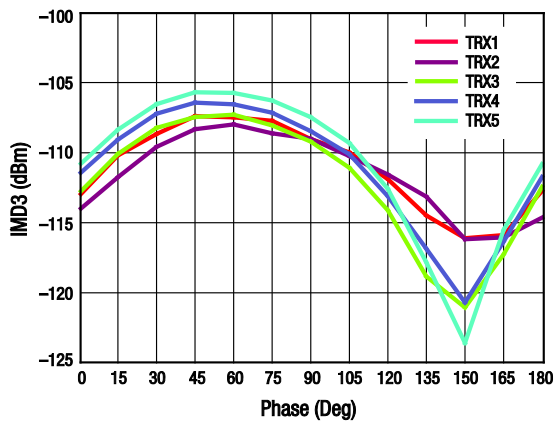

Figure 11. 3<sup>rd</sup> Order Intermodulation Distortion vs Phase, TRX Ports ( $f_{\text{FUND}} = 1.95 \text{ GHz}$ ,  $f_{\text{BLK}} = 1.76 \text{ GHz}$ ,  $f_{\text{RX}} = 2.14 \text{ GHz}$ )

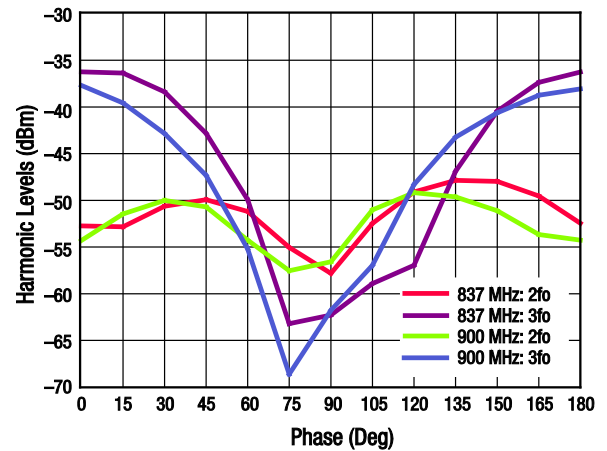
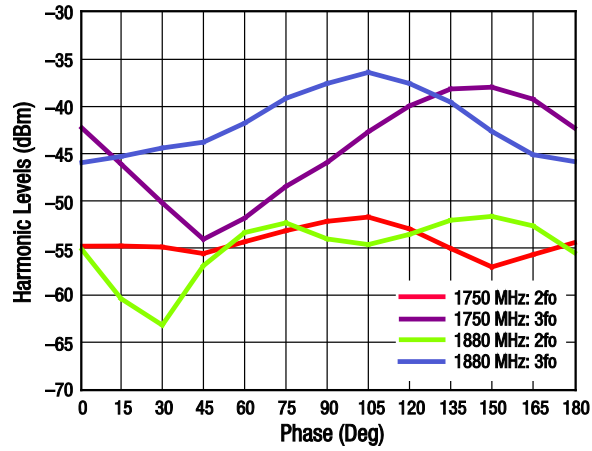
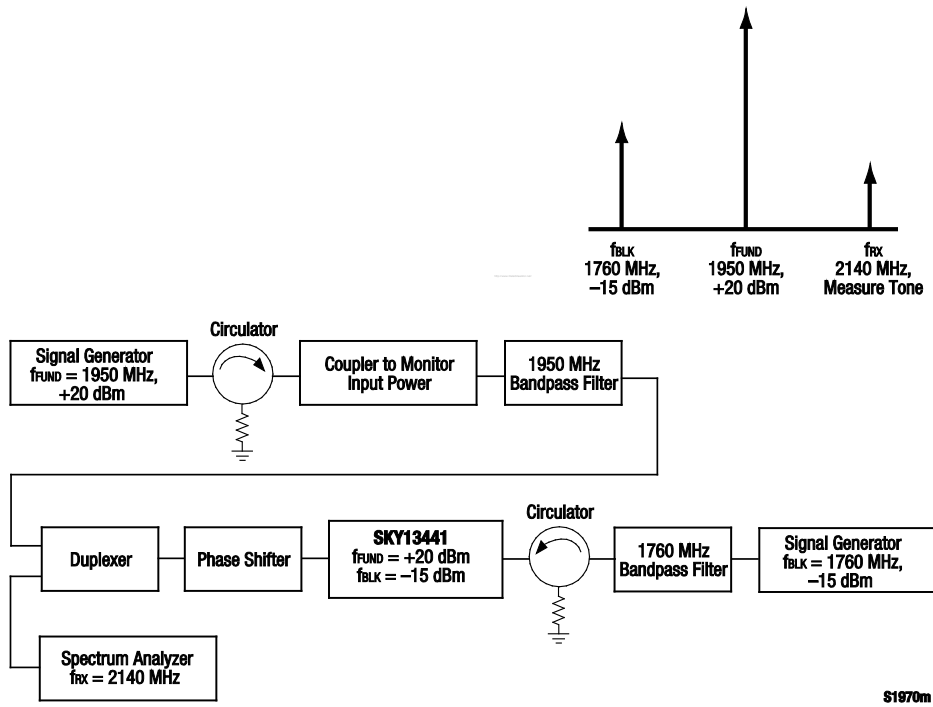

Figure 12. Harmonics vs Phase (ANT to TX1,  $P_{\text{IN}} = +35 \text{ dBm}$ , 5:1 VSWR Mismatch)



**Figure 13. Harmonics vs Phase**  
 (ANT to TX2, P<sub>IN</sub> = +33 dBm, 5:1 VSWR Mismatch)



**Figure 14. 3<sup>rd</sup> Order Intermodulation Test Setup**

S1970m



## Evaluation Board Description

The SKY13441 Evaluation Board is used to test the performance of the SKY13441 SP10T Switch. An Evaluation Board schematic diagram is provided in Figure 15. A recommended ESD protection circuit diagram is provided in Figure 16. An assembly drawing for the Evaluation Board is shown in Figure 17.

## Package Dimensions

The PCB layout footprint for the SKY13441 is provided in Figure 18. Typical case markings are shown in Figure 19. Package dimensions for the 20-pin MCM are shown in Figure 20, and tape and reel dimensions are provided in Figure 21.

## Package and Handling Information

Since the device package is sensitive to moisture absorption, it is baked and vacuum packed before shipping. Instructions on the shipping container label regarding exposure to moisture after the container seal is broken must be followed. Otherwise, problems related to moisture absorption may occur when the part is subjected to high temperature during solder assembly.

THE SKY13441 is rated to Moisture Sensitivity Level 3 (MSL3) at 260 °C. It can be used for lead or lead-free soldering. For additional information, refer to the Skyworks Application Note, *PCB Design and SMT Assembly/Rework Guidelines for MCM-L Packages*, document number 101752.

Care must be taken when attaching this product, whether it is done manually or in a production solder reflow environment. Production quantities of this product are shipped in a standard tape and reel format.

\*\*\* TBD \*\*\*

**Figure 15. SKY13441 Evaluation Board Schematic**

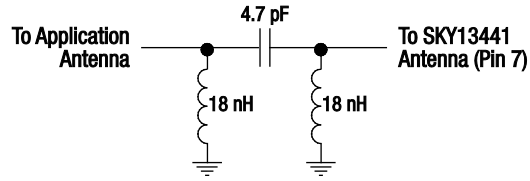

ESD Circuit 1

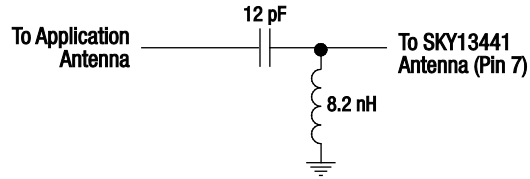

ESD Circuit 2

S2520g

Figure 16. SKY13441 Recommended ESD Protection Circuits

**\*\*\* TBD \*\*\***

**Figure 17. SKY13441 Evaluation Board Assembly Diagram**

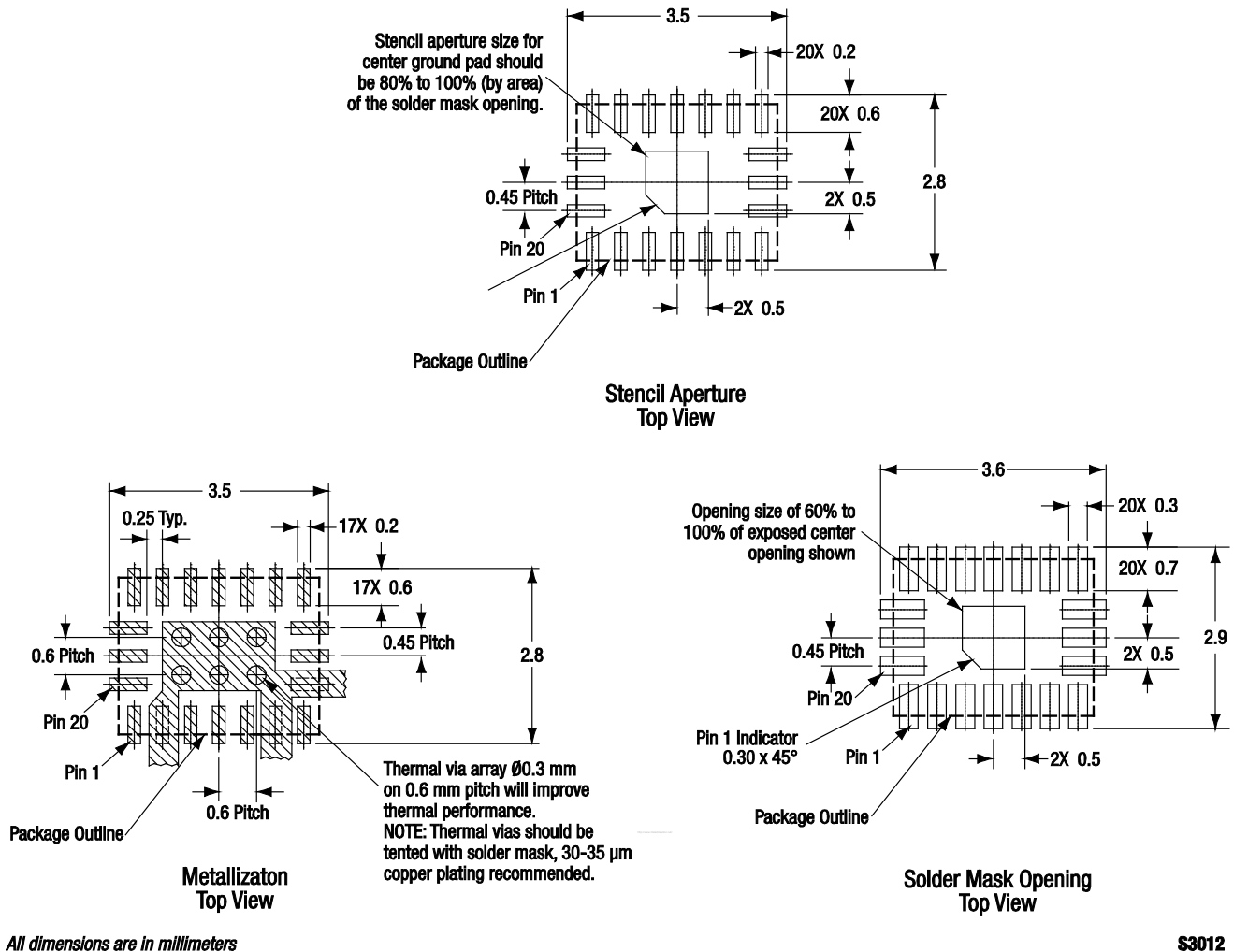
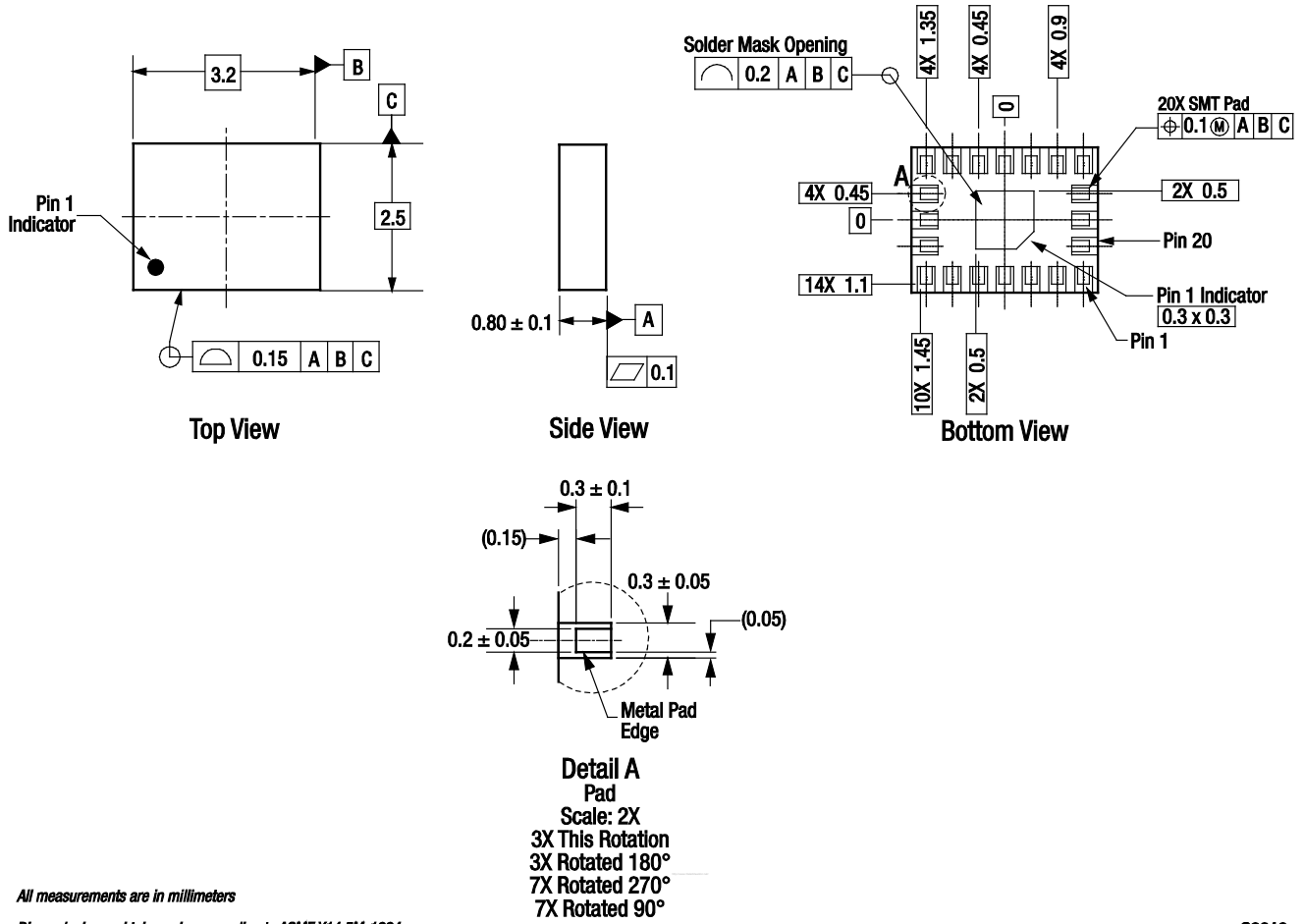

Figure 18. SKY13441 PCB Layout Footprint (Top View)

\*\*\* TBD \*\*\*

Figure 19. Typical Part Markings (Top View)



S3013

Figure 20. SKY13441 20-Pin MCM Package Dimensions

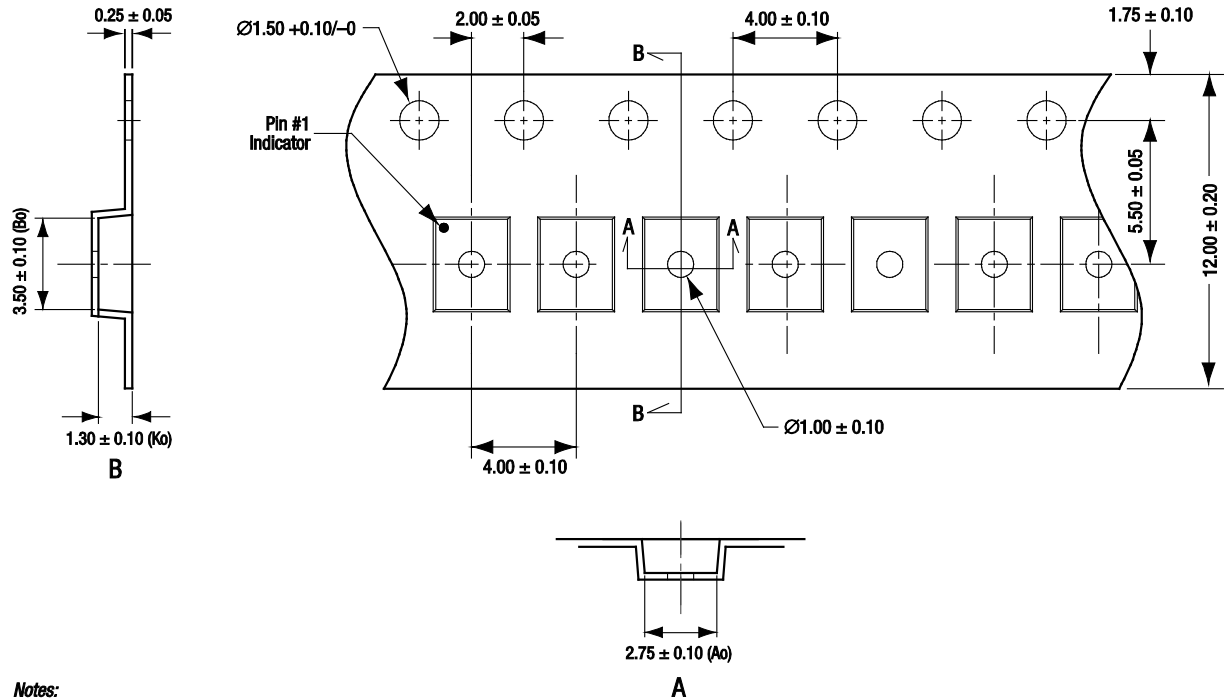

**Notes:**

1. Carrier tape: black conductive polycarbonate.
2. Cover tape material: transparent conductive material.
3. ESD-surface resistivity is  $\leq 1 \times 10^{10}$  Ohms/square per EIA, JEDEC TNR Specification.
4. 10 sprocket hole pitch cumulative tolerance:  $\pm 0.20$  mm
5.  $Ao$  and  $Bo$  measured on plane 0.30 mm above the bottom of the pocket.
6. All measurements are in millimeters.

S2686

**Figure 21. SKY13441 Tape and Reel Dimensions**

**Ordering Information**

Model Name	Manufacturing Part Number	Evaluation Board Part Number
SKY13441 0.4-2.2 GHz SP10T Switch	SKY13441	*** TBD ***

Copyright © 2012 Skyworks Solutions, Inc. All Rights Reserved.

Information in this document is provided in connection with Skyworks Solutions, Inc. (“Skyworks”) products or services. These materials, including the information contained herein, are provided by Skyworks as a service to its customers and may be used for informational purposes only by the customer. Skyworks assumes no responsibility for errors or omissions in these materials or the information contained herein. Skyworks may change its documentation, products, services, specifications or product descriptions at any time, without notice. Skyworks makes no commitment to update the materials or information and shall have no responsibility whatsoever for conflicts, incompatibilities, or other difficulties arising from any future changes.

No license, whether express, implied, by estoppel or otherwise, is granted to any intellectual property rights by this document. Skyworks assumes no liability for any materials, products or information provided hereunder, including the sale, distribution, reproduction or use of Skyworks products, information or materials, except as may be provided in Skyworks Terms and Conditions of Sale.

THE MATERIALS, PRODUCTS AND INFORMATION ARE PROVIDED “AS IS” WITHOUT WARRANTY OF ANY KIND, WHETHER EXPRESS, IMPLIED, STATUTORY, OR OTHERWISE, INCLUDING FITNESS FOR A PARTICULAR PURPOSE OR USE, MERCHANTABILITY, PERFORMANCE, QUALITY OR NON-INFRINGEMENT OF ANY INTELLECTUAL PROPERTY RIGHT; ALL SUCH WARRANTIES ARE HEREBY EXPRESSLY DISCLAIMED. SKYWORKS DOES NOT WARRANT THE ACCURACY OR COMPLETENESS OF THE INFORMATION, TEXT, GRAPHICS OR OTHER ITEMS CONTAINED WITHIN THESE MATERIALS. SKYWORKS SHALL NOT BE LIABLE FOR ANY DAMAGES, INCLUDING BUT NOT LIMITED TO ANY SPECIAL, INDIRECT, INCIDENTAL, STATUTORY, OR CONSEQUENTIAL DAMAGES, INCLUDING WITHOUT LIMITATION, LOST REVENUES OR LOST PROFITS THAT MAY RESULT FROM THE USE OF THE MATERIALS OR INFORMATION, WHETHER OR NOT THE RECIPIENT OF MATERIALS HAS BEEN ADVISED OF THE POSSIBILITY OF SUCH DAMAGE.

Skyworks products are not intended for use in medical, lifesaving or life-sustaining applications, or other equipment in which the failure of the Skyworks products could lead to personal injury, death, physical or environmental damage. Skyworks customers using or selling Skyworks products for use in such applications do so at their own risk and agree to fully indemnify Skyworks for any damages resulting from such improper use or sale.

Customers are responsible for their products and applications using Skyworks products, which may deviate from published specifications as a result of design defects, errors, or operation of products outside of published parameters or design specifications. Customers should include design and operating safeguards to minimize these and other risks. Skyworks assumes no liability for applications assistance, customer product design, or damage to any equipment resulting from the use of Skyworks products outside of stated published specifications or parameters.

Skyworks, the Skyworks symbol, and “Breakthrough Simplicity” are trademarks or registered trademarks of Skyworks Solutions, Inc., in the United States and other countries. Third-party brands and names are for identification purposes only, and are the property of their respective owners. Additional information, including relevant terms and conditions, posted at [www.skyworksinc.com](http://www.skyworksinc.com), are incorporated by reference.