

DATA SHEET

SKY13445-368LF: Dual-Band SP3T and SP2T Switch

Applications

- WLAN 802.11 a/b/g/n/ac networks
- Embedded modules

Features

- SP3T (2 GHz) and SP2T (5 GHz) switches with Bluetooth® capability
- Positive voltage control: 2.7 to 3.6 V
- IP0.5dB: +29.5 dBm typical @ 2.5 GHz and 3 V
- Small QFN (12-pin, 2 x 2 mm) package (MSL1, 260 °C per JEDEC J-STD-020)



Skyworks Green™ products are compliant with all applicable legislation and are halogen-free. For additional information, refer to *Skyworks Definition of Green™*, document number SQ04-0074.

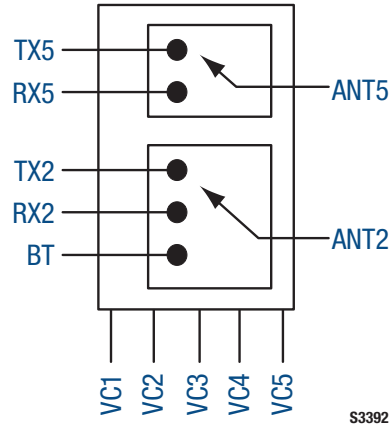

Figure 1. SKY13445-368LF Block Diagram

Description

The SKY13445-368LF is a pHEMT GaAs switch. The device includes a single-pole, triple-throw (SP3T) switch for 2 GHz WLAN transmit, receive, and Bluetooth functions, and a single-pole, double-throw (SP2T) switch for 5 GHz transmit and receive functions.

Any of the RF ports can be used for any RF function regardless of the port name. The SKY13445-368LF requires external DC blocking capacitors on all RF ports.

Both the SP3T and SP2T switches are fabricated on the same substrate. The active path is selected with five positive voltage control lines (V1, V2, and V3 for low band switching, and V4 and V5 for high band switching). In low band mode, the high band paths are in isolation by applying a low voltage to the two control lines, V4 and V5.

The switch is manufactured in a compact, 2 x 2 mm, 12-pin exposed pad plastic Quad Flat No-Lead (QFN) package.

A functional block diagram is shown in Figure 1. The pin configuration and package are shown in Figure 2. Signal pin assignments and functional pin descriptions are provided in Table 1.

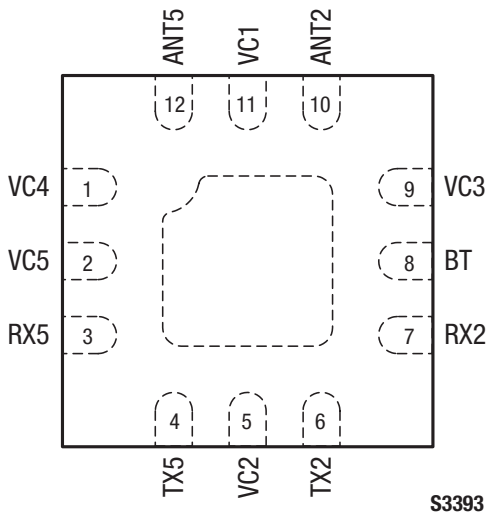

Figure 2. SKY13445-368LF Pinout – 12-Pin QFN (Top View)

Table 1. SKY13445-368LF Signal Descriptions (Note 1)

Pin	Name	Description	Pin	Name	Description
1	VC4	Control line 4 for ANT5 to RX5 path	7	RX2	2.4 to 2.5 GHz receive port. Must be DC blocked for proper operation.
2	VC5	Control line 5 for ANT5 to TX5 path	8	BT	Bluetooth RF port. Must be DC blocked for proper operation.
3	RX5	4.9 to 6.0 GHz receive port. Must be DC blocked for proper operation.	9	VC3	Control line 3 for ANT2 to RX2 path
4	TX5	4.9 to 6.0 GHz transmit port. Must be DC blocked for proper operation.	10	ANT2	2.4 to 2.5 GHz antenna port. Must be DC blocked for proper operation.
5	VC2	Control line 2 for ANT2 to TX2 path	11	VC1	Control line 1 for ANT2 to BT path
6	TX2	2.4 to 2.5 GHz transmit port. Must be DC blocked for proper operation.	12	ANT5	4.9 to 6.0 GHz antenna port. Must be DC blocked for proper operation.

Note 1: Bottom ground paddle must be connected to ground.

Table 2. SKY13445-368LF Absolute Maximum Ratings (Note 1)

Parameter	Symbol	Minimum	Maximum	Units
Control voltage (room temperature, normal operating power)	VCTL	-0.5	+5.0	V
RF input power (OFDM modulated): 2.5 GHz, SP3T switch	Pin2G		+31	dBm
5.0 GHz, SP2T switch	Pin5G		+29	dBm
Storage temperature	TSTG	-55	+150	°C
Operating temperature	TOP	-30	+90	°C

Note 1: Exposure to maximum rating conditions for extended periods may reduce device reliability. There is no damage to device with only one parameter set at the limit and all other parameters set at or below their nominal value. Exceeding any of the limits listed here may result in permanent damage to the device.

CAUTION: Although this device is designed to be as robust as possible, electrostatic discharge (ESD) can damage this device. This device must be protected at all times from ESD. Static charges may easily produce potentials of several kilovolts on the human body or equipment, which can discharge without detection. Industry-standard ESD precautions should be used at all times.

Electrical and Mechanical Specifications

The absolute maximum ratings of the SKY13445-368LF are provided in Table 2. Electrical specifications are provided in Tables 3 and 4.

The state of the SKY13445-368LF is determined by the logic provided in Table 5.

Typical performance characteristics of the SKY13445-368LF are illustrated in Figures 3 to 10.

Table 3. SKY13445-368LF Electrical Specifications (Note 1)
(V_{CTL} = 0 V [Low] and 3 V [High], T_{OP} = +25 °C, Characteristic Impedance [Z₀] = 50 Ω, Unless Otherwise Noted)

Parameter	Symbol	Test Condition	Min	Typical	Max	Units
2 GHz SP3T						
Insertion loss, 2 GHz	IL	ANT2 to RX2, TX2, and BT; f = 2.4 to 2.5 GHz		0.7	0.9	dB
Return loss (insertion loss state), 2 GHz	RL	ANT2 to RX2, TX2, and BT; f = 2.4 to 2.5 GHz	14	18		dB
Isolation, 2 GHz	Iso	ANT2 to RX2, TX2, and BT; one path on; f = 2.4 to 2.5 GHz	18	24		dB
Antenna isolation, 2 GHz	Iso	ANT2 to ANT5: One 2 GHz path on, f = 2.4 to 2.5 GHz	20	22		dB
		One 2 GHz path on, f = 4.8 to 5.0 GHz	20	22		dB
Switching speed		50% control to 90/10% RF steady state power		50		ns
Error vector magnitude	EVM	Input power for 2.5% error, WLAN 2.45 GHz, 802.11g, OFDM, 54 Mbps, 64 QAM	+20	+22		dBm
0.5 dB input compression point	IPO.5dB	f = 2.5 GHz	+27.0	+29.5		dBm
5 GHz SP2T						
Insertion loss, 5 GHz	IL	ANT5 to RX5 and TX5, f = 4.9 to 5.9 GHz		1.20	1.35	dB
Return loss (insertion loss state), 5 GHz	RL	ANT5 to RX2 and TX2, f = 4.9 to 5.9 GHz		13		dB
Isolation, 5 GHz	Iso	ANT5 to RX5, or ANT5 to TX5; one path on; f = 4.9 to 5.9 GHz	15.0	20.5		dB
Antenna isolation, 5 GHz	Iso	ANT2 to ANT5, one 5 GHz path on, f = 4.8 to 5.9 GHz	15	20		dB
Switching speed		50% control to 90/10% RF steady state power		50		ns
Error vector magnitude	EVM	Input power for 2.5% error, WLAN 4.9 to 6.0 GHz, 802.11g, OFDM, 54 Mbps, 64 QAM	+17.5	+19.0		dBm
0.5 dB input compression point	IPO.5dB	f = 5.0 GHz	+26	+28		dBm

Note 1: Performance is guaranteed only under the conditions listed in this table.

Table 4. SKY13445-368LF Electrical Specifications (Note 1)
(V_{CTL} = 3 V, T_{OP} = +25 °C, Characteristic Impedance [Z₀] = 50 Ω, Unless Otherwise Noted)

Parameter	Symbol	Test Condition	Min	Typical	Max	Units
Control voltage: Low	V _{CTL_L}		0		0.2	V
High	V _{CTL_H}		2.7	3.0	5.0	V
Leakage current	I _{LEAK}	VC1/2/3/4/5 = 3 V		15	30	μA

Note 1: Performance is guaranteed only under the conditions listed in this table.

Table 5. SKY13445-368LF Truth Table (Note 1)

Function	Control Signal Logic					Insertion Loss/Isolation State				
	VC1 (Pin 11)	VC2 (Pin 5)	VC3 (Pin 9)	VC4 (Pin 1)	VC5 (Pin 2)	ANT2 to BT	ANT2 to TX2	ANT2 to RX2	ANT5 to Rx5	ANT5 to TX5
ANT2 to BT	1	0	0	0	0	Insertion Loss	Isolation	Isolation	Isolation	Isolation
ANT2 to TX2	0	1	0	0	0	Isolation	Insertion Loss	Isolation	Isolation	Isolation
ANT2 to RX2	0	0	1	0	0	Isolation	Isolation	Insertion Loss	Isolation	Isolation
ANT5 to RX5	0	0	0	1	0	Isolation	Isolation	Isolation	Insertion Loss	Isolation
ANT5 to TX5	0	0	0	0	1	Isolation	Isolation	Isolation	Isolation	Insertion Loss
ANT2 to BT, ANT5 to RX5	1	0	0	1	0	Insertion Loss	Isolation	Isolation	Insertion Loss	Isolation
ANT2 to BT, ANT5 to TX5	1	0	0	0	1	Insertion Loss	Isolation	Isolation	Isolation	Insertion Loss
ANT2 to TX2, ANT5 to RX5	0	1	0	1	0	Isolation	Insertion Loss	Isolation	Insertion Loss	Isolation
ANT2 to TX2, ANT5 to TX5	0	1	0	0	1	Isolation	Insertion Loss	Isolation	Isolation	Insertion Loss
ANT2 to RX2, ANT5 to RX5	0	0	1	1	0	Isolation	Isolation	Insertion Loss	Insertion Loss	Isolation
ANT2 to RX2, ANT5 to TX5	0	0	1	0	1	Isolation	Isolation	Insertion Loss	Isolation	Insertion Loss

Note 1: Any state other than described in this Table places the switch into an undefined state. An undefined state will not damage the device.

Typical Performance Characteristics

($V_{CTL} = 0\text{ V [Low]}$ and 3 V [High] , $T_{OP} = +25\text{ }^{\circ}\text{C}$, Characteristic Impedance [Z_0] = $50\ \Omega$, Unless Otherwise Noted)

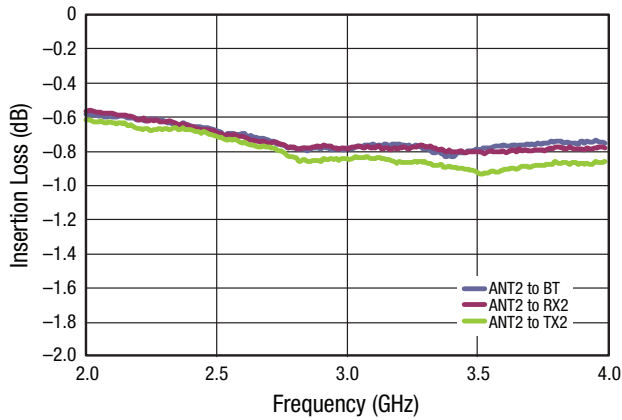

Figure 3. Typical Insertion Loss vs Frequency (2 GHz, SP3T)

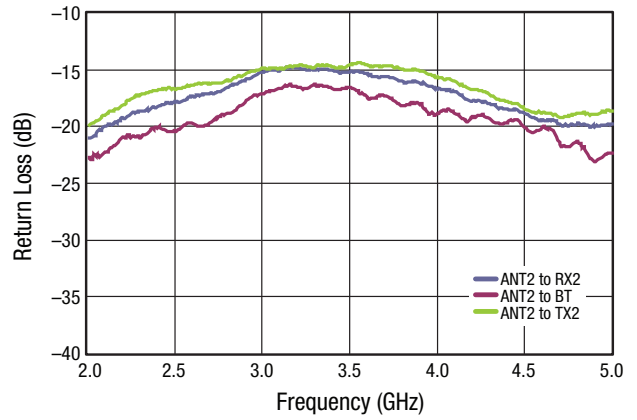

Figure 4. Typical Input Return Loss vs Frequency (2 GHz, SP3T)

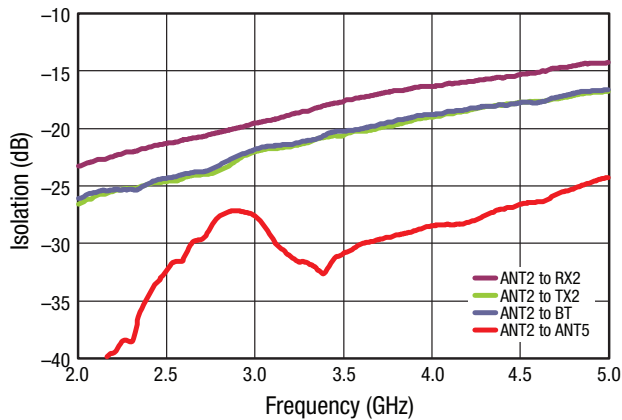

Figure 5. Typical Isolation vs Frequency (2 GHz, SP3T)

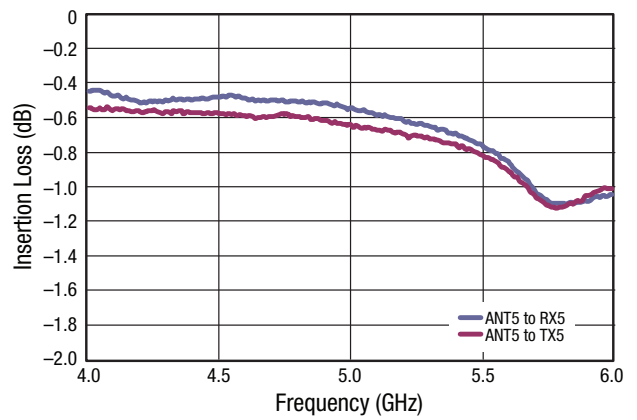

Figure 6. Typical Insertion Loss vs Frequency (5 GHz, SP2T)

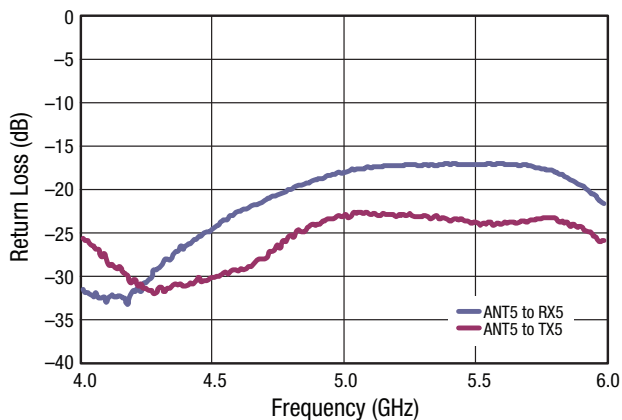

Figure 7. Typical Input Return Loss vs Frequency (5 GHz, SP2T)

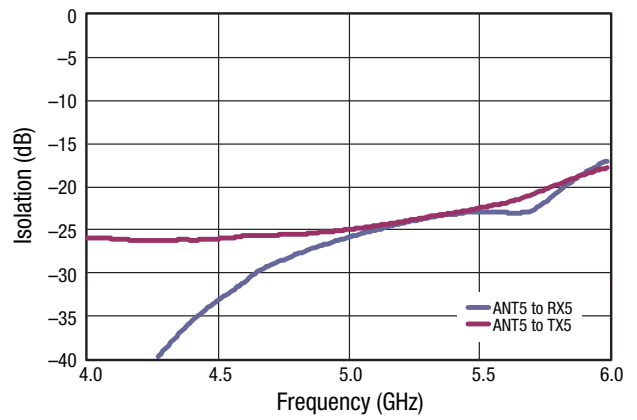

Figure 8. Typical Isolation vs Frequency (5 GHz, SP5T)

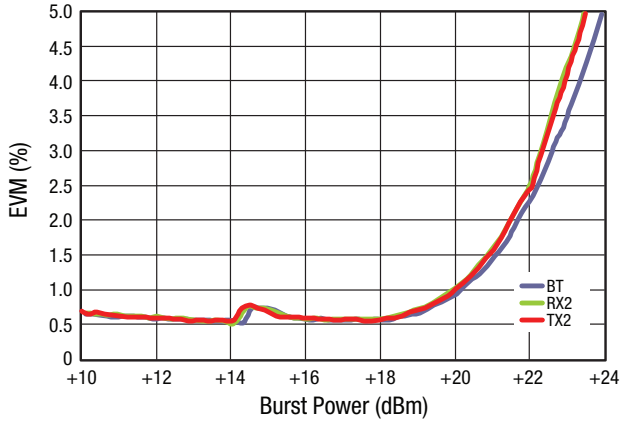

Figure 9. Typical EVM vs Burst Power @ 2500 MHz

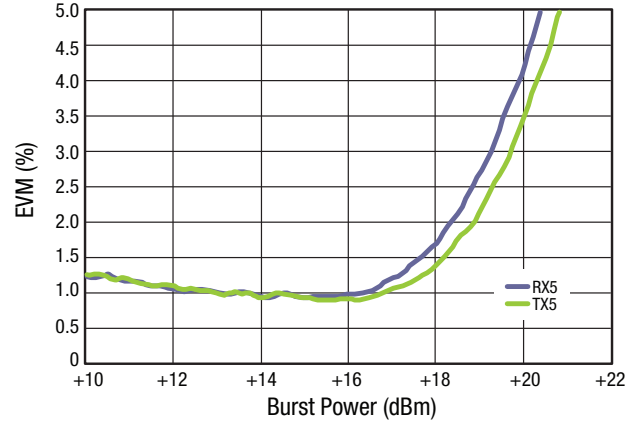

Figure 10. Typical EVM vs Burst Power @ 5500 MHz

Evaluation Board Description

The SKY13445-368LF Evaluation Board is used to test the performance of the SKY13445-368LF dual-band switch. An Evaluation Board schematic diagram is provided in Figure 11. An assembly drawing for the Evaluation Board is shown in Figure 12.

Package Dimensions

The PCB layout footprint for the SKY13445-368LF is provided in Figure 13. Typical part markings are shown in Figure 14. Package dimensions are shown in Figure 15, and tape and reel dimensions are provided in Figure 16.

Package and Handling Information

Instructions on the shipping container label regarding exposure to moisture after the container seal is broken must be followed. Otherwise, problems related to moisture absorption may occur when the part is subjected to high temperature during solder assembly.

The SKY13445-368LF is rated to Moisture Sensitivity Level 1 (MSL1) at 260 °C. It can be used for lead or lead-free soldering. For additional information, refer to the Skyworks Application Note, *Solder Reflow Information*, document number 200164.

Care must be taken when attaching this product, whether it is done manually or in a production solder reflow environment. Production quantities of this product are shipped in a standard tape and reel format.

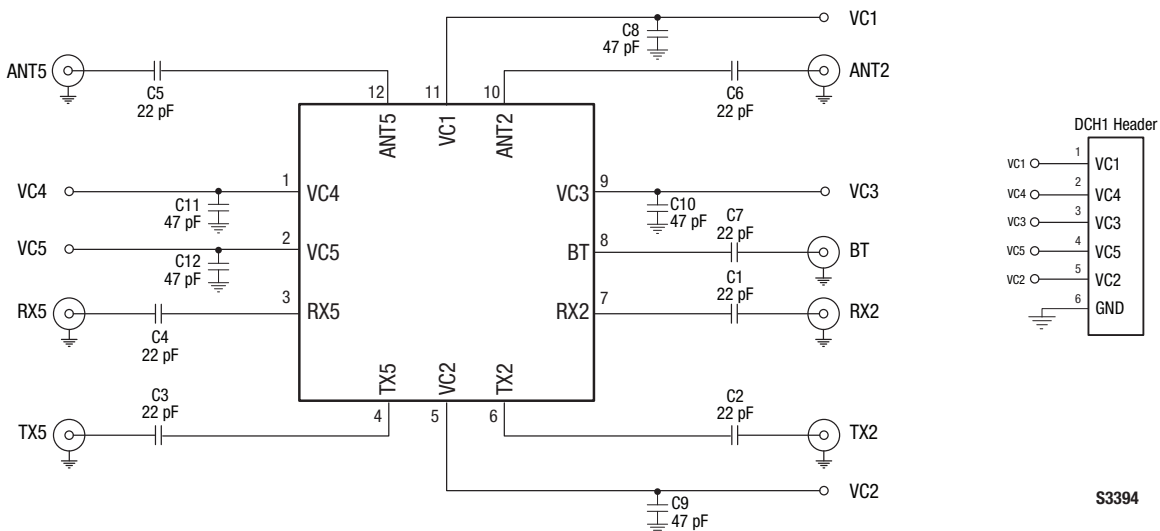

Figure 11. SKY13445-368LF Evaluation Board Schematic

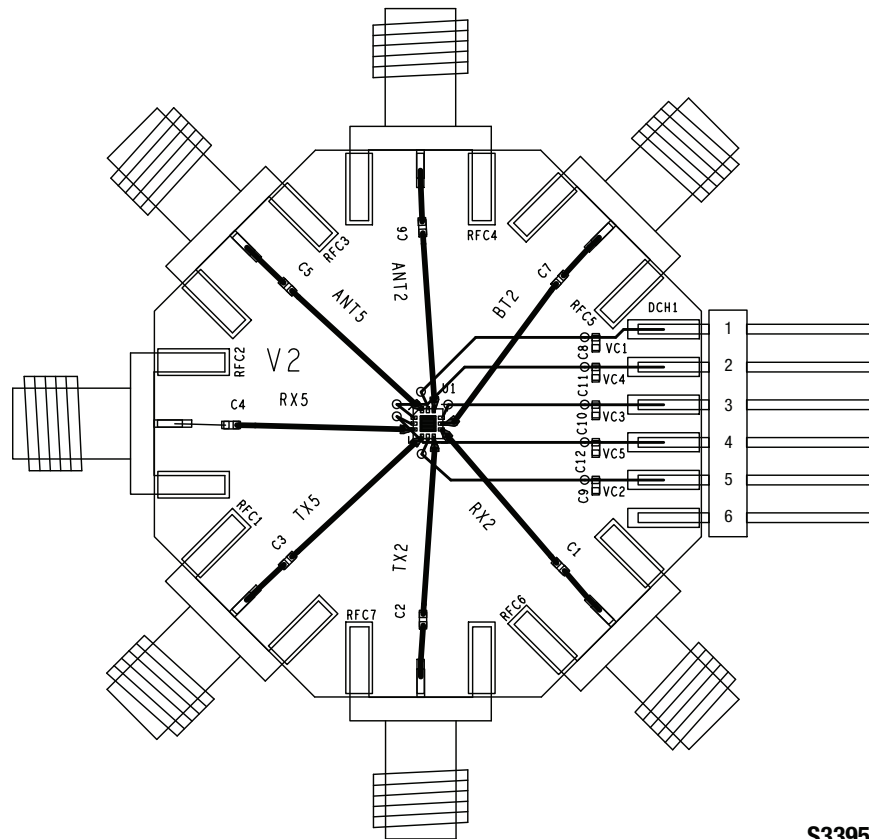

Figure 12. SKY13445-368LF Evaluation Board Assembly Diagram

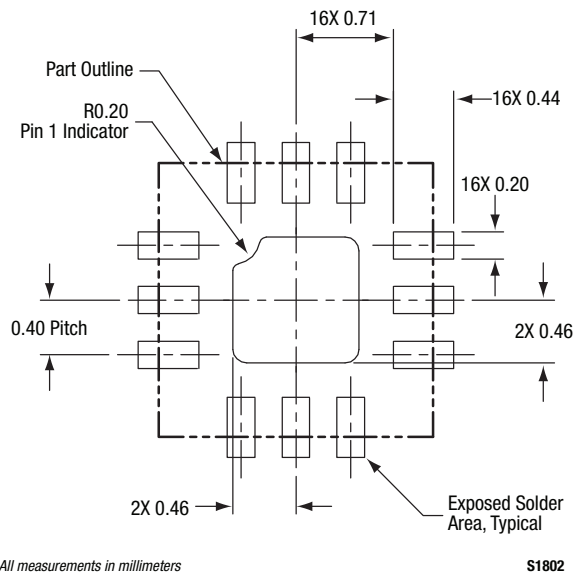
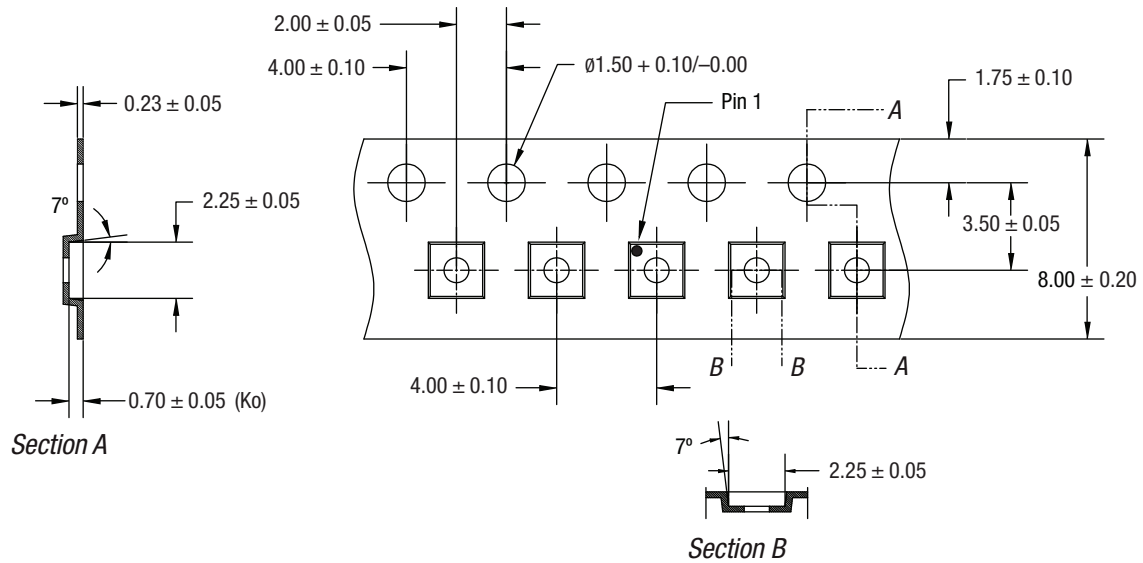

Figure 13. SKY13445-368LF PCB Layout Footprint (Top View)



Notes:

1. Carrier tape must meet all requirements of Skyworks GP01-D232 procurement spec for tape and reel shipping.
2. Carrier tape shall be black conductive polycarbonate bakeable material at 125 °C temperature.
3. Cover tape shall be transparent conductive with 5.40 mm width.
4. ESD-surface resistivity must meet all ESD requirements of Skyworks specified on GP01-D232.
5. All measurements are in millimeters.

ts737

Figure 16. SKY13445-368LF Tape and Reel Dimensions

Ordering Information

Model Name	Manufacturing Part Number	Evaluation Board Part Number
SKY13445-368LF Dual-Band SP2T and SP3T Switch	SKY13445-368LF	SKY13445-368LF-EVB

Copyright © 2013-2015 Skyworks Solutions, Inc. All Rights Reserved.

Information in this document is provided in connection with Skyworks Solutions, Inc. (“Skyworks”) products or services. These materials, including the information contained herein, are provided by Skyworks as a service to its customers and may be used for informational purposes only by the customer. Skyworks assumes no responsibility for errors or omissions in these materials or the information contained herein. Skyworks may change its documentation, products, services, specifications or product descriptions at any time, without notice. Skyworks makes no commitment to update the materials or information and shall have no responsibility whatsoever for conflicts, incompatibilities, or other difficulties arising from any future changes.

No license, whether express, implied, by estoppel or otherwise, is granted to any intellectual property rights by this document. Skyworks assumes no liability for any materials, products or information provided hereunder, including the sale, distribution, reproduction or use of Skyworks products, information or materials, except as may be provided in Skyworks Terms and Conditions of Sale.

THE MATERIALS, PRODUCTS AND INFORMATION ARE PROVIDED “AS IS” WITHOUT WARRANTY OF ANY KIND, WHETHER EXPRESS, IMPLIED, STATUTORY, OR OTHERWISE, INCLUDING FITNESS FOR A PARTICULAR PURPOSE OR USE, MERCHANTABILITY, PERFORMANCE, QUALITY OR NON-INFRINGEMENT OF ANY INTELLECTUAL PROPERTY RIGHT; ALL SUCH WARRANTIES ARE HEREBY EXPRESSLY DISCLAIMED. SKYWORKS DOES NOT WARRANT THE ACCURACY OR COMPLETENESS OF THE INFORMATION, TEXT, GRAPHICS OR OTHER ITEMS CONTAINED WITHIN THESE MATERIALS. SKYWORKS SHALL NOT BE LIABLE FOR ANY DAMAGES, INCLUDING BUT NOT LIMITED TO ANY SPECIAL, INDIRECT, INCIDENTAL, STATUTORY, OR CONSEQUENTIAL DAMAGES, INCLUDING WITHOUT LIMITATION, LOST REVENUES OR LOST PROFITS THAT MAY RESULT FROM THE USE OF THE MATERIALS OR INFORMATION, WHETHER OR NOT THE RECIPIENT OF MATERIALS HAS BEEN ADVISED OF THE POSSIBILITY OF SUCH DAMAGE.

Skyworks products are not intended for use in medical, lifesaving or life-sustaining applications, or other equipment in which the failure of the Skyworks products could lead to personal injury, death, physical or environmental damage. Skyworks customers using or selling Skyworks products for use in such applications do so at their own risk and agree to fully indemnify Skyworks for any damages resulting from such improper use or sale.

Customers are responsible for their products and applications using Skyworks products, which may deviate from published specifications as a result of design defects, errors, or operation of products outside of published parameters or design specifications. Customers should include design and operating safeguards to minimize these and other risks. Skyworks assumes no liability for applications assistance, customer product design, or damage to any equipment resulting from the use of Skyworks products outside of stated published specifications or parameters.

Skyworks and the Skyworks symbol are trademarks or registered trademarks of Skyworks Solutions, Inc., in the United States and other countries. Third-party brands and names are for identification purposes only, and are the property of their respective owners. Additional information, including relevant terms and conditions, posted at www.skyworksinc.com, are incorporated by reference.