

DATA SHEET

SKY66108-11: 2.4 GHz ZigBee®/Smart Energy Front-End Module

Applications

- Smart meters
- In-home appliances
- Smart thermostats

Features

- Integrated:
 - PA with up to +16 dBm output power
 - LNA with programmable bypass
 - Transmit and receive switching function
- +2.7 dB FEM Rx NF
- Differential Rx/Tx interface with integrated balun
- Fast switch on/off time <800 ns
- 2.0 V to 3.6 V supply operation
- Sleep mode current 0.05 μ A typical
- QFN (20-pin, 3.0 mm x 3.0 mm x 0.55 mm) package (MSL1 @ 260 °C per JEDEC J-STD-020)



Skyworks Green™ products are compliant with all applicable legislation and are halogen-free. For additional information, refer to *Skyworks Definition of Green™*, document number SQ04-0074.

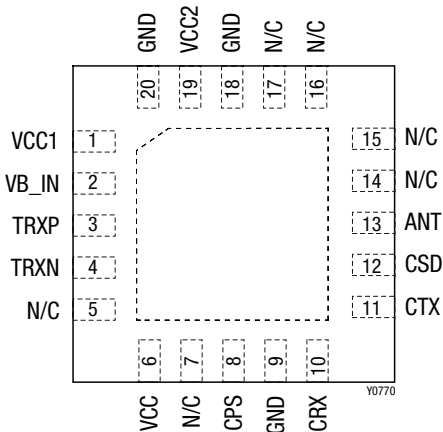

Figure 2. SKY66108-11 Pinout—20-Pin QFN (Top View)

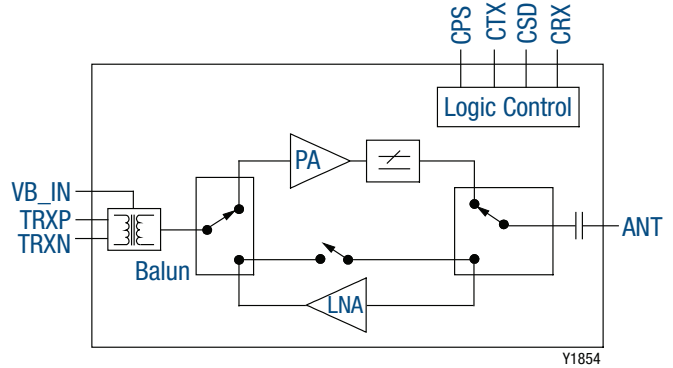

Figure 1. SKY66108-11 Block Diagram

Description

The SKY66108-11 is a high-performance, fully integrated RF Front-End Module (FEM) that is designed for ZigBee®/Smart Energy applications.

The SKY66108-11 is designed for ease of use and maximum flexibility, with integrated fully matched input balun, integrated inter-stage matching and harmonic filter, and digital controls that are compatible with 1.6 V to 3.6 V Complementary Metal Oxide Semiconductor (CMOS) levels.

The RF blocks operate over a wide supply voltage range from 2.0 V to 3.6V, which allows the SKY66108-11 to be used in battery-powered applications over a wide spectrum of the battery discharge curve.

A functional block diagram is shown in Figure 1. The pin configuration and package are shown in Figure 2. Signal pin assignments and functional pin descriptions are provided in Table 1.

Table 1. SKY66108-11 Signal Descriptions

Pin	Name	Description	Pin	Name	Description
1	VCC1	Positive supply	12	CSD	Sleep mode control
2	VB_IN	Bias voltage input supply to the transceiver (see Figure 3)	13	ANT	Connect to 50 Ω antenna
3	TRXP	Input/output signal to the transceiver, 100 Ω differential	14	N/C	Not connected
4	TRXN	Input/output signal to the transceiver, 100 Ω differential	15	N/C	Not connected
5	N/C	Not connected	16	N/C	Not connected
6	VCC	Positive supply	17	N/C	Not connected
7	N/C	Not connected	18	GND	Connect to PCB ground
8	CPS	Bypass mode control, connect to RFIC or SoC GPIO	19	VCC2	Positive supply
9	GND	Connect to PCB the ground	20	GND	Connect to PCB ground
10	CRX	Receive function control	Paddle	GND	Exposed die paddle; electrical and thermal ground; connect to PCB ground
11	CTX	Transmit function control			

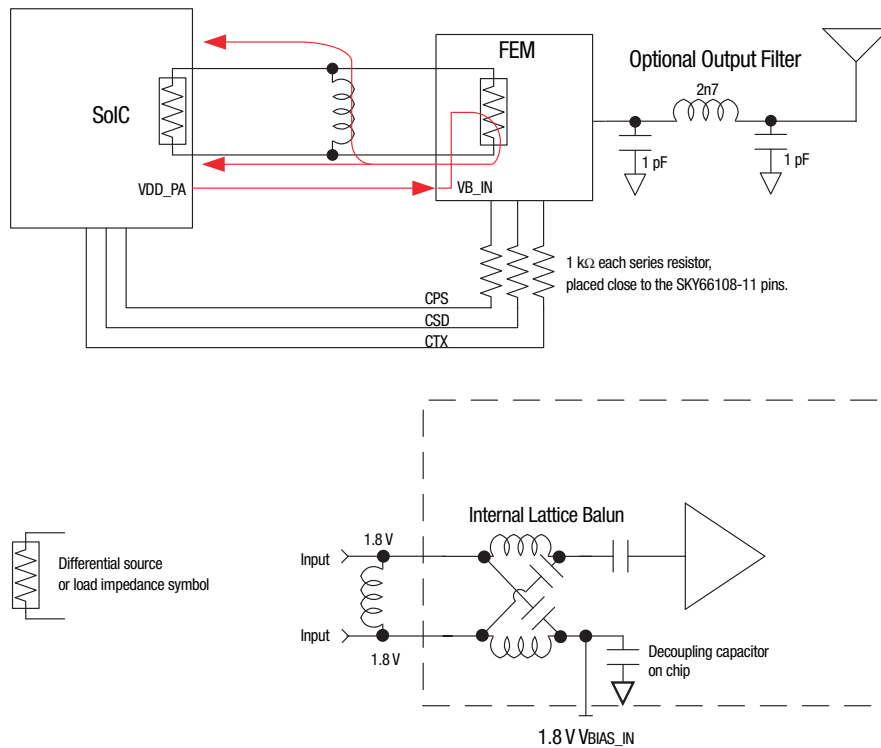

The balun at the FEM PA input (or LNA output) can also be used to inject a bias operating point for the transceiver output stage (the shunt inductor provides a DC path on the other side). The inductor also tunes out any parasitic capacitance.

If the SOIC transceiver does not require a DC bias, leave the VB_IN open.

Y1902

Figure 3. Injecting a Bias Operating Point for the Transceiver Output Stage

Electrical and Mechanical Specifications

The absolute maximum ratings of the SKY66108-11 are provided in Table 2. The recommended operating conditions are specified in Table 3.

The electrical specifications are provided in Tables 4 through 7. The state of the SKY66108-11 is determined by the logic provided in Table 8.

Table 2. SKY66108-11 Absolute Maximum Ratings

Parameter	Symbol	Minimum	Maximum	Units
Supply voltage	V _{CC1} , V _{CC2} , V _{CC3}	-0.3	3.6	V
Control pin voltages		-0.3	3.6	V
Operating temperature	T _A	-40	125	°C
Storage temperature	T _{STG}	-40	125	°C
Tx output power at the ANT port into 50 Ω load	P _{OUT_TX_MAX}		+16	dBm
Tx input power at the TR port	P _{IN_TX_MAX}		+6	dBm
Rx input power at the ANT port	P _{IN_RX_MAX}		+5	dBm
Thermal resistance	θ _{JC}		69	°C/W
Electrostatic discharge: Human Body Model (HBM), Class 1C	ESD		1000	V

Note: Exposure to maximum rating conditions for extended periods may reduce device reliability. There is no damage to device with only one parameter set at the limit and all other parameters set at or below their nominal value. Exceeding any of the limits listed here may result in permanent damage to the device.

CAUTION: Although this device is designed to be as robust as possible, electrostatic discharge (ESD) can damage this device. This device must be protected at all times from ESD. Static charges may easily produce potentials of several kilovolts on the human body or equipment, which can discharge without detection. Industry-standard ESD precautions should be used at all times.

Table 3. Recommended Operating Conditions

Parameter	Symbol	Minimum	Typical	Maximum	Units
Ambient temperature	T _A	-40	+25	+125	°C
Supply voltage for transceiver core	V _{B_IN}	1.6		3.6	V
Supply voltage on Vcc pins	V _{CC1} , V _{CC2} , V _{CC3}	2.0	3.0	3.6	V

Table 4. SKY66108-11 Electrical Specifications: DC (Note 1)
(VCC = VCC1 = VCC2 = 3 V, TA = +25 °C, Measured on the Evaluation Board [De-embedded to the Device], Unless Otherwise Noted)

Parameter	Symbol	Test Condition	Min	Typical	Max	Units
Total supply current	I _{CC_TX14}	Tx mode P _{OUT} = +14 dBm		33		mA
Total supply current	I _{CC_TX12}	Tx mode P _{OUT} = +12 dBm		25		mA
Total supply current	I _{CC_TX10}	Tx mode P _{OUT} = +10 dBm		20		mA
Quiescent current	I _{CC_TX}	No RF		6		mA
Total supply current	I _{CC_RXHG}	Rx Low Noise Amplifier (LNA) High Gain mode		5.5		mA
Total supply current	I _{CC_RXLG}	Rx LNA Low Gain mode		2.7		mA
Total supply current	I _{CC_RxBypass}	Rx Bypass mode			10	μA
Sleep supply current	I _{CC_OFF}	No RF		0.05	1.0	μA

Note 1: Performance is guaranteed only under the conditions listed in this table.

Table 5. SKY66108-11 Electrical Specifications: Logic Characteristics (Note 1)
(VCC = VCC1 = VCC2 = 3.0 V, TA = +25 °C, Measured on the Evaluation Board [De-embedded to the Device], Unless Otherwise Noted)

Parameter	Symbol	Test Condition	Min	Typical	Max	Units
Logic input high voltage	V _{BIHB}		1.6		3.6	V
Logic input low voltage	V _{BILB}		0		0.3	V
Logic input high current	I _{BIHB}				1	μA
Logic input low current	I _{BILB}				1	μA

Note 1: Performance is guaranteed only under the conditions listed in this table.

Table 6. SKY66108-11 Electrical Specifications: AC Characteristics (Note 1)
(VCC = VCC1 = VCC2 = 3.0 V, TA = +25 °C, Measured on the Evaluation Board [De-embedded to the Device],
All Unused Ports Terminated with 50 Ω, Unless Otherwise Noted)

Parameter	Symbol	Test Condition	Minimum	Typical	Maximum	Units
Transmit (Tx)						
Frequency range	f _{IN}		2400		2483	MHz
Output power at ANT port	P _{OUT_HI}	2400 MHz to 2483 MHz, OEVM = 1% typical: VCC = VCC1 = VCC2 = 3.6 V VCC = VCC1 = VCC2 = 3.3 V VCC = VCC1 = VCC2 = 3.0 V VCC = VCC1 = VCC2 = 2.0 V VCC = VCC1 = VCC2 = 1.8 V		+16.0 +15.0 +14.0 +11.0 +9.5		dBm
Small signal gain high power mode	S _{21_HI}	2400 MHz to 2483 MHz	14			dB
Small signal gain variation	ΔS ₂₁	2400 MHz to 2483 MHz Gain variation across all 802.15.4 channels			1	dBp-p
Second and third harmonics	H _{D2} , H _{D3}	2400 MHz to 2483 MHz IEEE 802.15.4 source P _{OUT} = +14 dBm Measured with the antenna match and filter components per the SKY66108-11-EK1 evaluation board			-42	dBm/ MHz
Bluetooth® V 1.0 and BLE spectral mask	ACPR	ACPR @ ± 2 channels ACPR @ ± 3 channels		> -40 > -40		dB dB
Turn on and off times	t _{ON} t _{OFF}	From 50% of the CTX edge to 90% of the final RF output power. From 50% of the CTX edge to 10% of the final RF output power.			800	ns
Stability	STAB	CW, PIN = +0 dBm 0.1 GHz to 20.0 GHz Load VSWR = 6:1	All non-harmonically related outputs <-35.0 dBm/MHz			
Ruggedness	Ru	CW, PIN = +6 dBm, Load VSWR = 10:1	No permanent damage			
Receive (Rx)						
Frequency range	f _{IN}		2400		2483	MHz
Rx gain high-gain mode	Rx_gain_HG	2400 MHz to 2483 MHz	10.3	12.3	14.3	dB
Rx gain low-gain mode	Rx_gain_LG	2400 MHz to 2483 MHz	5	7	9	dB
Rx noise figure (NF) high-gain mode	NF_HG	2400 MHz to 2483 MHz		2.7		dB
Rx NF low-gain mode	NF_LG	2400 MHz to 2483 MHz		+3.8		dB
Input 1 dB compression point high-gain mode	IP1dB_HG	2400 MHz to 2483 MHz	-13	-8		dBm
Input 1 dB compression point low-gain mode	IP1dB_LG	2400 MHz to 2483 MHz	-3	+2		dBm
Turn on and off times	t _{ON} t _{OFF}	From 50% of the CTX edge to 90% of the final RF output power. From 50% of the CTX edge to 10% of the final RF output power.			800	ns
Gain in bypass mode	G_bp			-3.5		dB
Input 1 dB compression point in bypass mode	IP1dB		+10			dBm

Note 1: Performance is guaranteed only under the conditions listed in this table.

Table 7. SE2438T Electrical Specifications: AC Characteristics, Antenna Switch (Note 1)
(Vcc1 = Vcc2 = Vcc3 = 3 V, TA = +25 °C, Measured on the Evaluation Board [De-embedded to the Device],
All Unused Ports Terminated with 50 Ω, Unless Otherwise Noted)

Parameter	Symbol	Min	Typical	Max	Units
Input return loss at ANT port, Rx mode	S11		-10	-5	dB
Output return loss at ANT port, Tx mode	S22		-10	-5	dB

Note 1: Performance is guaranteed only under the conditions listed in this table.

Table 8. SKY66108-11 Logic Controls (Notes 1 and 2)
(VCC = VCC1 = VCC2 = 3.0 V, TA = +25 °C, Unless Otherwise Noted)

Mode	Description	CSD	CPS	CRX	CTX	Current Consumption
0	All off	0	0	0	0	Table 4
1	Standby	0	0	0	1	1.907 μA
2	Standby	0	0	1	0	1.907 μA
3	Standby	0	0	1	1	3.8 μA
4	Standby	0	1	0	0	1.907 μA
5	Standby	0	1	0	1	3.8 μA
6	Standby	0	1	1	0	3.8 μA
7	Standby	0	1	1	1	5.69 μA
8	Standby	1	0	0	0	1.907 μA
9	Tx bypass mode	1	0	0	1	Same as Rx Bypass mode (Table 4)
10	Rx bypass mode	1	0	1	0	Table 4
11	Regulator enabled	1	0	1	1	210 μA
12	Rx LNA (LG)	1	1	0	0	Table 4
13	TX high power mode	1	1	0	1	Table 4
14	Rx LNA(HG)	1	1	1	0	Table 4
15	Standby	1	1	1	1	7.6 μA

Note 1: Performance is guaranteed only under the conditions listed in this table.

Note 2: Modes 1 through 8, 11, and 15 are for internal use only.

Evaluation Board Description

The SKY66108-11 Evaluation Board is used to test the performance of the SKY66108-11 FEM. The board is optimized for evaluation, experimentation, and investigation with an 802.15.4 signal source. The design and layout can be quickly and easily transferred into a production design.

An Evaluation Board schematic diagram is provided in Figure 4. A reference design schematic is provided in Figure 5. Table 9 describes the pins on the power and control I/O header (J3). Table 10 provides the Bill of Materials (BOM) list for Evaluation Board components. A photograph of the Evaluation Board is shown in Figure 6.

Evaluation Board Setup Procedure

1. Connect (J1, J2) to 50 Ω instruments. Terminate all unused ports (if applicable) with 50 Ω .
2. Connect the supply ground to pin 19 or 20 of J3.
3. Connect 3.0 V to VCC, VCC1, and VCC2 of J3.
4. Connect 1.8 V to Pin 8 of J3.
5. Monitor the 2.5 GHz amplifier transmit performance by applying an RF signal to J2 and monitoring the output power on J1 (ANT).
6. Monitor the 2.5 GHz amplifier receive performance by applying an RF signal to connector J1 (ANT) and monitoring the output signal on connector J2.

CAUTION: Care should be taken not to overdrive the amplifier by applying too much RF on the input to the device. A suitable starting input power would be -20 dBm.

Package Dimensions

The PCB layout footprint for the SKY66108-11 is provided in Figure 7. Typical part markings for the SKY66108-11 are shown in Figure 8. Package dimensions are shown in Figure 9, and tape and reel dimensions are provided in Figure 10.

Package and Handling Information

Instructions on the shipping container label regarding exposure to moisture after the container seal is broken must be followed. Otherwise, problems related to moisture absorption may occur when the part is subjected to high temperature during solder assembly.

The SKY66108-11 package is Pb free, RoHS compliant, halogen free, and rated to Moisture Sensitivity Level 1 (MSL1). For additional information, refer to the Skyworks Application Note, *Solder Reflow Information*, document number 200164.

Care must be taken when attaching this product, whether it is done manually or in a production solder reflow environment. Production quantities of this product are shipped in a standard tape and reel format.

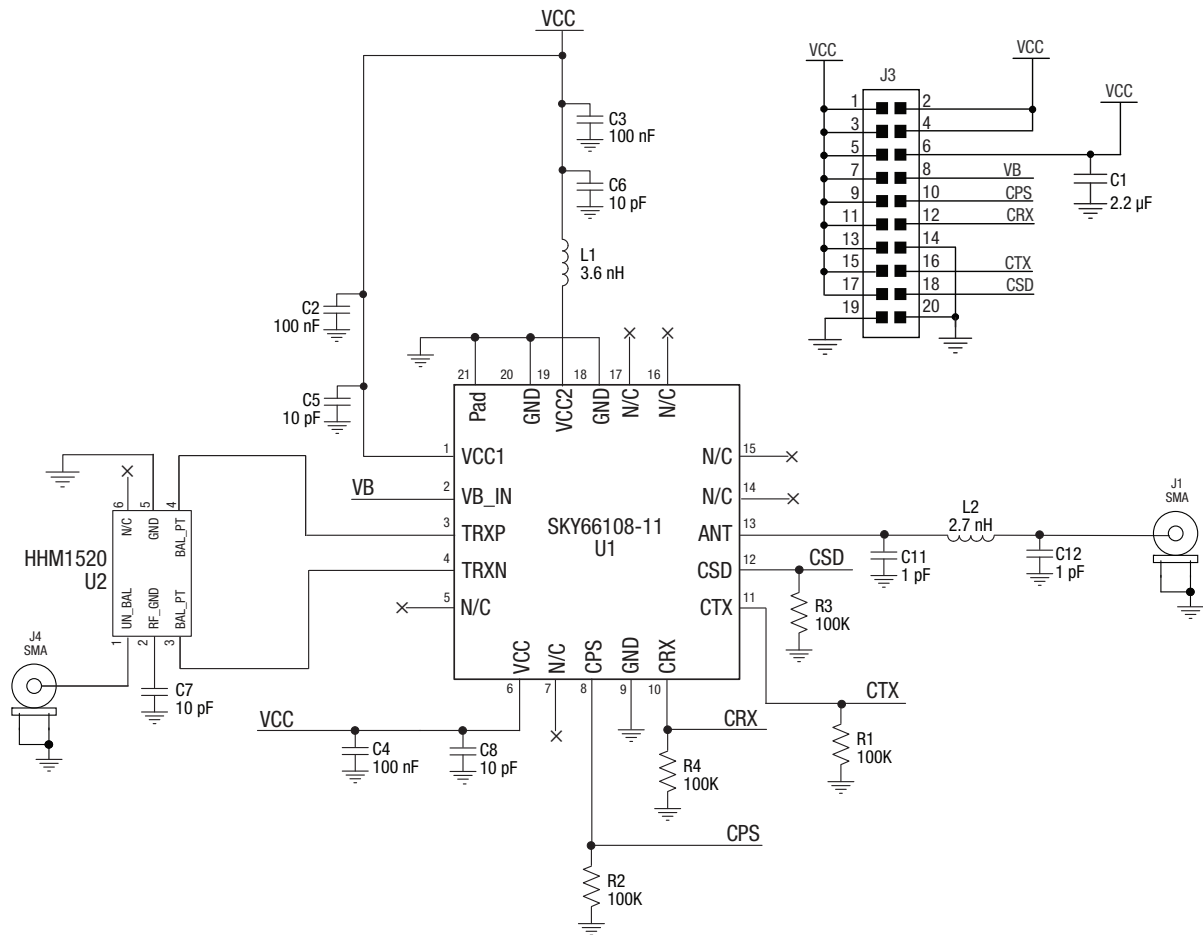

PCB Recommendations:

Metal Layer 1 = RF traces + control lines. Core thickness between top RF layer and ground plane is critical.
 Metal Layer 2 = Solid ground plane. No traces routing.
 Metal Layer 3 and 4 = Control lines + VCC traces (no VCC plane).
 Pour copper on each layer connected to the ground plane. Use VCC traces in a star distribution pattern.

Y1903

Figure 4. SKY66108-11 Evaluation Board Schematic

Table 9. SKY66108-11 Power and Analog I/O Header: J3, 10x2

Pin Number	Evaluation Board Label	Description	Recommended setting
14, 19, 20	GND	Ground	General purpose grounds
1, 3, 5, 6, 7, 9, 11, 13, 15, 17	VCC	Supply voltage	General purpose VCC provided as the main power supply
4	VCC1	Supply voltage	General purpose VCC provided as the main power supply
2	VCC2	Supply voltage	General purpose VCC provided as the main power supply
8	VB	Bias	Output bias to transceiver
16	CTX	Control	See Table 8
10	CPS	Control	
18	CSD	Control	
12	CRX	Control	

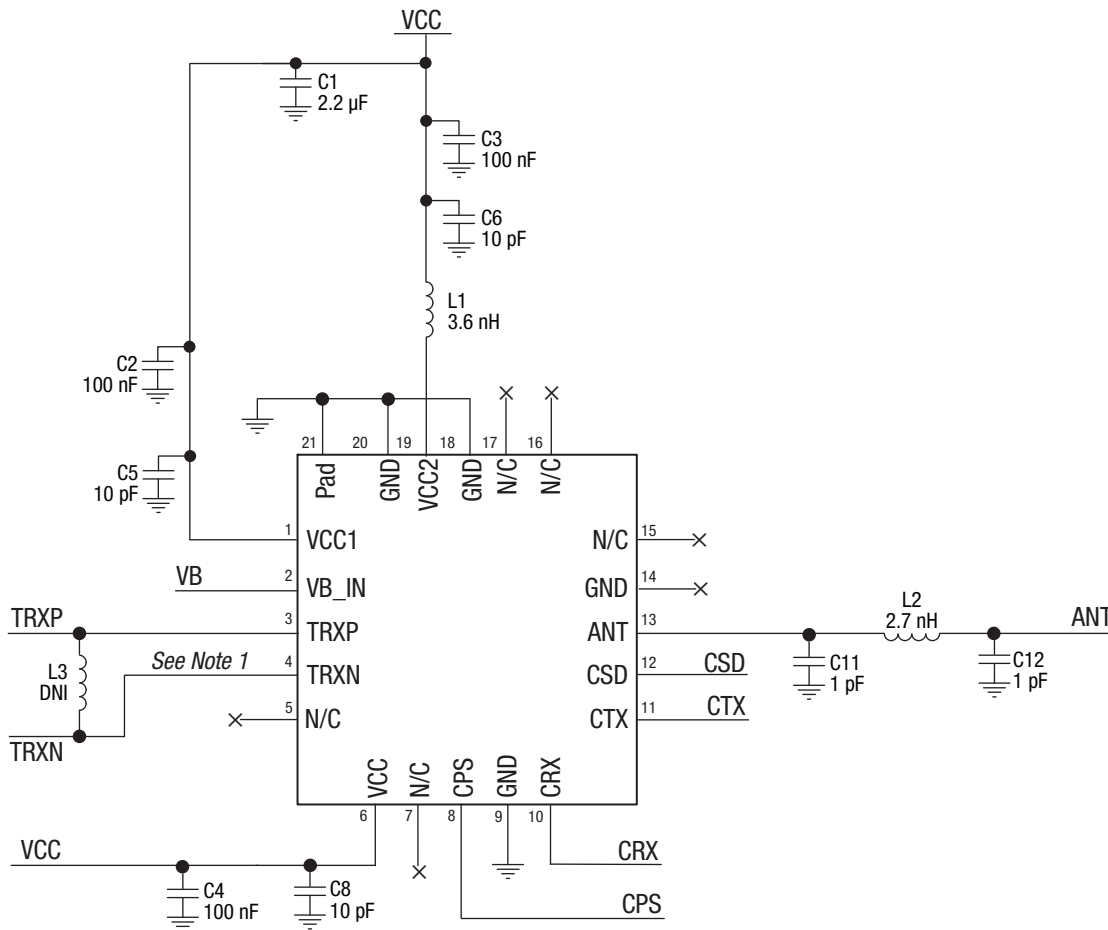

Note 1:

There are two ways that the SKY66108-11 input can be interface single ended:

1. One input can be terminated with 50 Ω to ground, the other input impedance is 50 Ω.
2. One input can be shorted to ground, the other input impedance is 100 Ω.

Y1904

Figure 5. SKY66108-11 Evaluation Board Reference Design Schematic

Table 10. SKY66108-11 Evaluation Board Bill of Materials

Description	Value	Manufacturer	Mfr Part Number	Package	Description
C1	2.2 μ F	Murata	GRM21BR71A225KA01L	0805	Capacitor ceramic 2.2 μ F 10 V 10% X7R 0805
L2	2.7 nH	Murata	LQG15HN2N7S02D	0402	High frequency multilayer
L1	3.6 nH	Murata	LQG15HN3N6S02D	0402	High frequency multilayer
J3	10 x 2	Samtec	TSW-110-07-G-D	100 mil	100 mil header
U2	HHM1520	TDK	HHM1520	2.00MMX1.25	Multilayer chip baluns 2.4 GHz
U1	SKY66108-11	Skyworks	SKY66108-11	QFN3X3-20	2.4 GHz 14 dBm FEIC
C11, C12	1 pF	Murata	GRM1555C1H1R0CZ01	0402	Multilayer ceramic
J1, J2	SMA	Johnson Components	142-0701-851	End Launch	SMA end launch straight jack receptacle—tab contact
C2, C3, C4	100 nF	Murata	GRM155R71C104KA88D	0402	Monolithic ceramic
C5, C6, C7, C8	10 pF	Murata	GRM1555C1H100JZ01	0402	Multilayer ceramic
R1, R2, R3, R4	100 k Ω	Panasonic	ERJ2GEJ104	0402	Thick film chip resistor

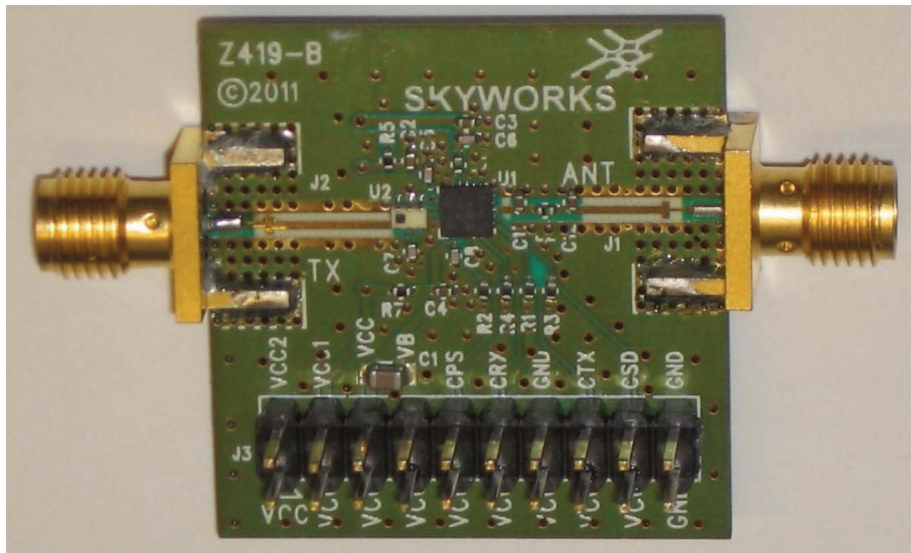

Y0771

Figure 6. SKY66108-11 Evaluation Board Photograph

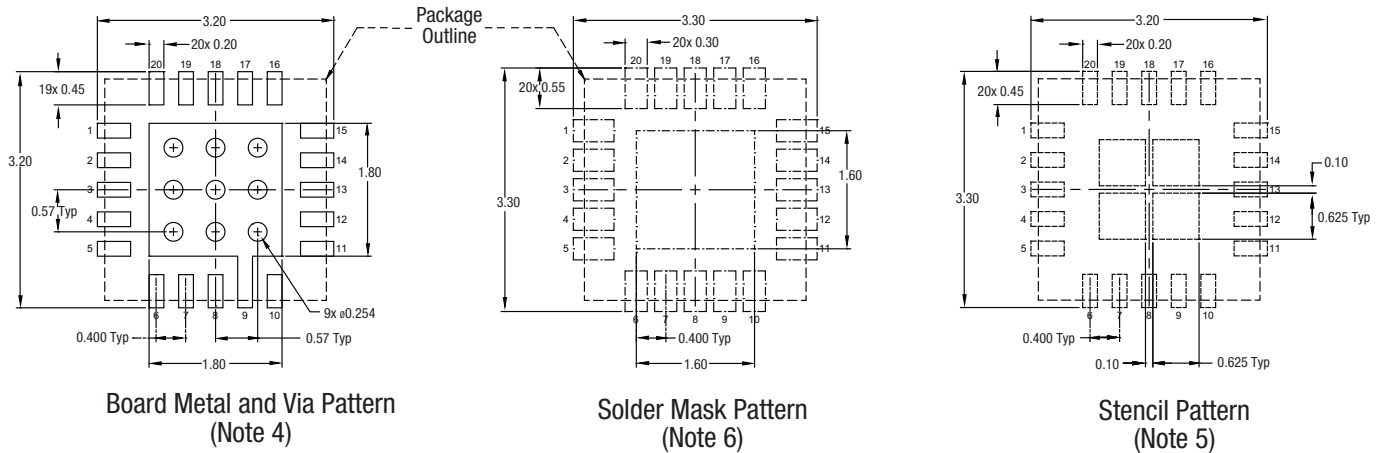

Notes:

1. All dimensions are in millimeters.
2. Dimensions and tolerances according to ASME Y14.5M-1994.
3. Unless specified, dimensions are symmetrical about center lines.
4. Via hole recommendations: 30 to 35 μ m Cu via wall plating (minimum), via holes should be tented with solder mask on the back side and filled with solder.
5. Stencil recommendations: 0.125 mm stencil thickness, laser cut apertures, trapezoidal walls and rounded corners offer better paste release.
6. Solder mask recommendations: contact board fabricator for recommended solder mask offset and tolerance.

61% solder coverage
on center pad

Y0774

Figure 7. PCB Layout Footprint

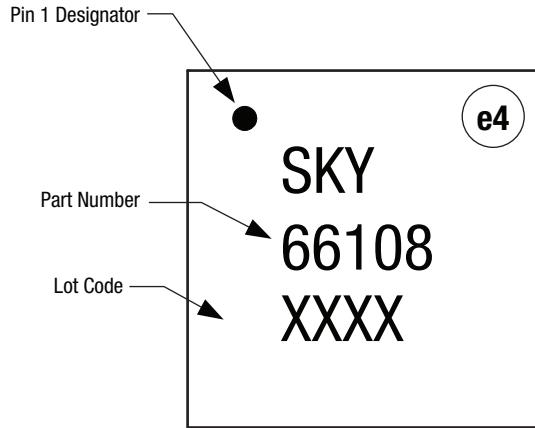
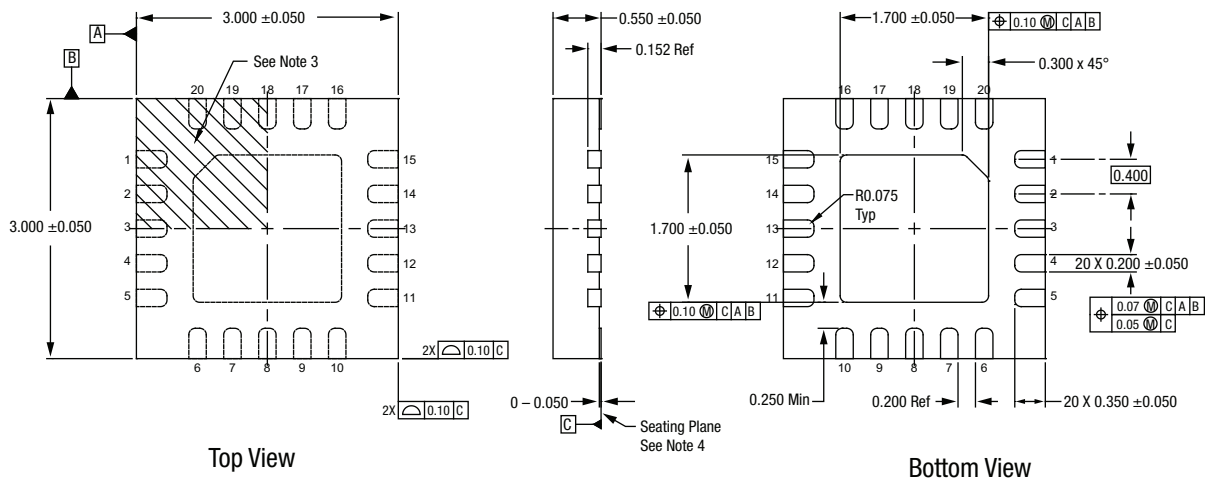

Figure 8. SKY66108-11 Part Markings (Top View)



Notes:

1. All dimensions are in millimeters.
2. Dimensions and tolerances according to ASME Y14.5--1994.
3. Terminal 1 identification mark located within this area.
4. Unilateral coplanarity zone applies to the exposed heat sink ground pad as well as the terminals.

Y0773

Figure 9. SKY66108-11 Package Dimensions

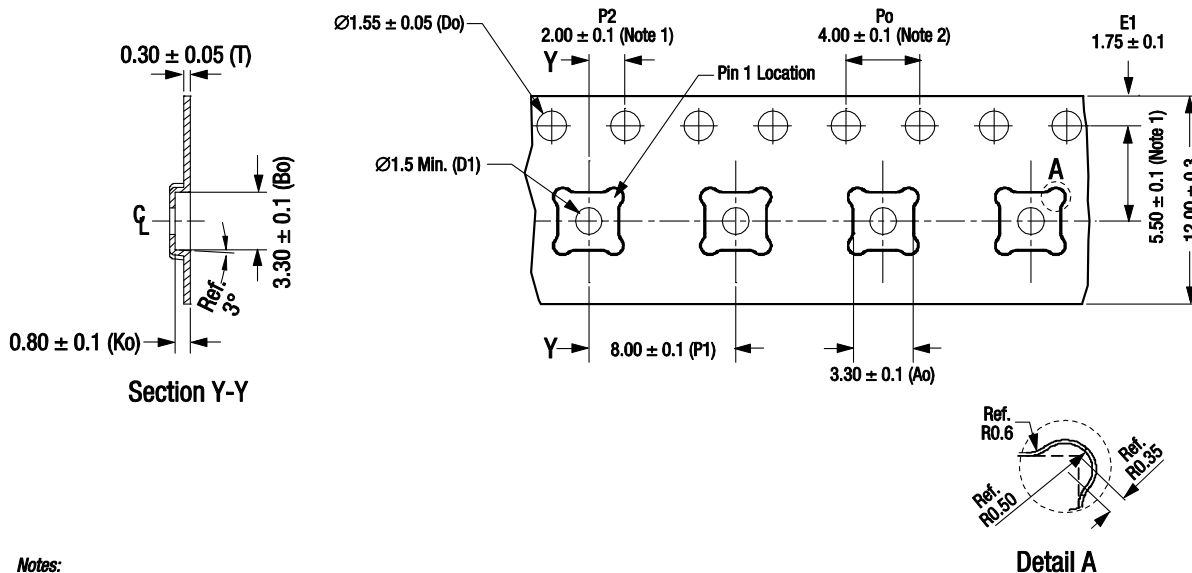

Notes:

1. Measured from center line of sprocket hole to center line of pocket.
2. Cumulative tolerance of 10 sprocket holes is ± 0.20 mm.
3. Other material available.
4. Typical ESD surface resistivity is from 10^5 to 10^{11} Ohms/square per EIA, JEDEC tape and reel specification.

All measurements are in millimeters.

S2615

Figure 10. SKY66108-11 Tape and Reel Dimensions

Ordering Information

Model Name	Manufacturing Part Number	Evaluation Board Part Number
SKY66108-11: 2.4 GHz Smart Energy/ZigBee Front-End Module	SKY66108-11	SKY66108-11-EK1

Copyright © 2012-2015 Skyworks Solutions, Inc. All Rights Reserved.

Information in this document is provided in connection with Skyworks Solutions, Inc. ("Skyworks") products or services. These materials, including the information contained herein, are provided by Skyworks as a service to its customers and may be used for informational purposes only by the customer. Skyworks assumes no responsibility for errors or omissions in these materials or the information contained herein. Skyworks may change its documentation, products, services, specifications or product descriptions at any time, without notice. Skyworks makes no commitment to update the materials or information and shall have no responsibility whatsoever for conflicts, incompatibilities, or other difficulties arising from any future changes.

No license, whether express, implied, by estoppel or otherwise, is granted to any intellectual property rights by this document. Skyworks assumes no liability for any materials, products or information provided hereunder, including the sale, distribution, reproduction or use of Skyworks products, information or materials, except as may be provided in Skyworks Terms and Conditions of Sale.

THE MATERIALS, PRODUCTS AND INFORMATION ARE PROVIDED "AS IS" WITHOUT WARRANTY OF ANY KIND, WHETHER EXPRESS, IMPLIED, STATUTORY, OR OTHERWISE, INCLUDING FITNESS FOR A PARTICULAR PURPOSE OR USE, MERCHANTABILITY, PERFORMANCE, QUALITY OR NON-INFRINGEMENT OF ANY INTELLECTUAL PROPERTY RIGHT; ALL SUCH WARRANTIES ARE HEREBY EXPRESSLY DISCLAIMED. SKYWORKS DOES NOT WARRANT THE ACCURACY OR COMPLETENESS OF THE INFORMATION, TEXT, GRAPHICS OR OTHER ITEMS CONTAINED WITHIN THESE MATERIALS. SKYWORKS SHALL NOT BE LIABLE FOR ANY DAMAGES, INCLUDING BUT NOT LIMITED TO ANY SPECIAL, INDIRECT, INCIDENTAL, STATUTORY, OR CONSEQUENTIAL DAMAGES, INCLUDING WITHOUT LIMITATION, LOST REVENUES OR LOST PROFITS THAT MAY RESULT FROM THE USE OF THE MATERIALS OR INFORMATION, WHETHER OR NOT THE RECIPIENT OF MATERIALS HAS BEEN ADVISED OF THE POSSIBILITY OF SUCH DAMAGE.

Skyworks products are not intended for use in medical, lifesaving or life-sustaining applications, or other equipment in which the failure of the Skyworks products could lead to personal injury, death, physical or environmental damage. Skyworks customers using or selling Skyworks products for use in such applications do so at their own risk and agree to fully indemnify Skyworks for any damages resulting from such improper use or sale.

Customers are responsible for their products and applications using Skyworks products, which may deviate from published specifications as a result of design defects, errors, or operation of products outside of published parameters or design specifications. Customers should include design and operating safeguards to minimize these and other risks. Skyworks assumes no liability for applications assistance, customer product design, or damage to any equipment resulting from the use of Skyworks products outside of stated published specifications or parameters.

Skyworks and the Skyworks symbol are trademarks or registered trademarks of Skyworks Solutions, Inc., in the United States and other countries. Third-party brands and names are for identification purposes only, and are the property of their respective owners. Additional information, including relevant terms and conditions, posted at www.skyworksinc.com, are incorporated by reference.