

PRODUCT SUMMARY

SKY74068-11: Dual-Band, Dual-Mode Transmitter for CDMA, AMPS, and PCS Mobile Handset Applications

Applications

- Dual-band, dual-mode handsets
- Cellular and PCS band phones
 - CDMA and AMPS modes in the cellular band
 - CDMA mode in the PCS band

Features

- Low power consumption in all operating modes
- Direct upconversion architecture
- Device controlled using a three-wire read/write serial bus interface with independent supply voltage
- Baseband RC filter to reject receive band noise
- Fully integrated VCO with auto-tuning
- Dual-mode fractional-N/integer-N PLL
- Variable gain PA drivers
- Differential cellular driver output matched to 200 Ω
- Single-ended PCS driver output matched to 50 Ω
- Transmit power control with >85 dB dynamic range
- Low current consumption at low transmit power minimizes current consumption and noise
- Hardware TX_ENABLE for gated mode operation
- RFLGA™ (32-pin, 5 x 5 x 1 mm) Pb-free (MSL3, 260 °C per JEDEC J-STD-020) package with downset paddle

NEW

Skyworks offers lead (Pb)-free, RoHS (Restriction of Hazardous Substances) compliant packaging.



Description

The SKY74068-11 transmitter is a highly integrated device for dual-band Code Division Multiple Access (CDMA) handsets in the cellular CDMA, Advanced Mobile Phone System (AMPS), and Personal Communications System (PCS) modes.

The device requires a minimum number of external components to complete a CDMA radio subsystem. Included on-chip are the baseband filter, direct upconversion In-Phase and Quadrature (I/Q) mixers, variable gain power amplifier (PA) drivers, a fully integrated Voltage Controlled Oscillator (VCO) with Local Oscillator (LO) generation blocks, and a dual-mode fractional-N/integer-N Phase Locked Loop (PLL).

External components needed for operation include bias resistors, bypass capacitors, and passives to comprise the PLL loop filter.

The signal enters the chip as an analog baseband I/Q signal. It is filtered by the baseband filter and upconverted to the desired RF transmit frequency. The signal is amplified by one of two upconverters, depending on whether the chip is operating in cellular or PCS mode. The resulting signal is fed through the appropriate PA driver stage to provide variable output power and to drive the external PA. The signal is then filtered by an external Surface Acoustic Wave (SAW) filter and sent to the PA to obtain the final rated power.

A functional block diagram for the SKY74068-11 is shown in Figure 1.

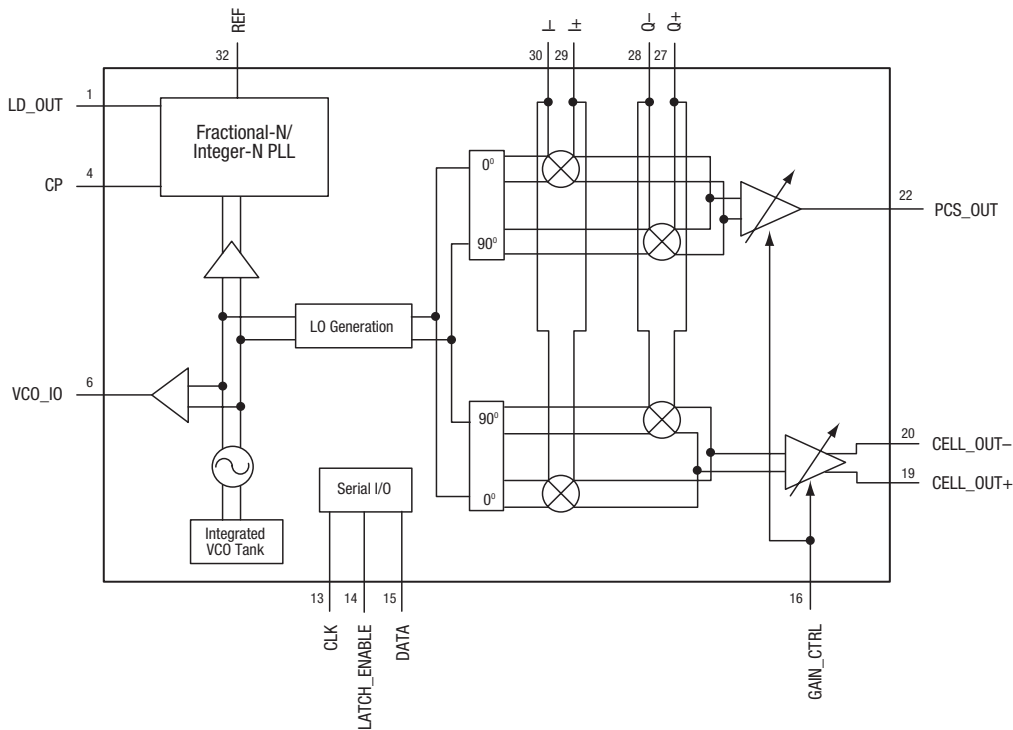

Figure 1. SKY74068-11 Transmitter Block Diagram

Ordering Information

Model Name	Manufacturing Part Number	Evaluation Kit Part Number
SKY74068-11 Transmitter	SKY74068-11 (Pb-free package)	

Copyright © 2006, 2007 Skyworks Solutions, Inc. All Rights Reserved.

Information in this document is provided in connection with Skyworks Solutions, Inc. (“Skyworks”) products or services. These materials, including the information contained herein, are provided by Skyworks as a service to its customers and may be used for informational purposes only by the customer. Skyworks assumes no responsibility for errors or omissions in these materials or the information contained herein. Skyworks may change its documentation, products, services, specifications or product descriptions at any time, without notice. Skyworks makes no commitment to update the materials or information and shall have no responsibility whatsoever for conflicts, incompatibilities, or other difficulties arising from any future changes.

No license, whether express, implied, by estoppel or otherwise, is granted to any intellectual property rights by this document. Skyworks assumes no liability for any materials, products or information provided hereunder, including the sale, distribution, reproduction or use of Skyworks products, information or materials, except as may be provided in Skyworks Terms and Conditions of Sale.

THE MATERIALS, PRODUCTS AND INFORMATION ARE PROVIDED “AS IS” WITHOUT WARRANTY OF ANY KIND, WHETHER EXPRESS, IMPLIED, STATUTORY, OR OTHERWISE, INCLUDING FITNESS FOR A PARTICULAR PURPOSE OR USE, MERCHANTABILITY, PERFORMANCE, QUALITY OR NON-INFRINGEMENT OF ANY INTELLECTUAL PROPERTY RIGHT; ALL SUCH WARRANTIES ARE HEREBY EXPRESSLY DISCLAIMED. SKYWORKS DOES NOT WARRANT THE ACCURACY OR COMPLETENESS OF THE INFORMATION, TEXT, GRAPHICS OR OTHER ITEMS CONTAINED WITHIN THESE MATERIALS. SKYWORKS SHALL NOT BE LIABLE FOR ANY DAMAGES, INCLUDING BUT NOT LIMITED TO ANY SPECIAL, INDIRECT, INCIDENTAL, STATUTORY, OR CONSEQUENTIAL DAMAGES, INCLUDING WITHOUT LIMITATION, LOST REVENUES OR LOST PROFITS THAT MAY RESULT FROM THE USE OF THE MATERIALS OR INFORMATION, WHETHER OR NOT THE RECIPIENT OF MATERIALS HAS BEEN ADVISED OF THE POSSIBILITY OF SUCH DAMAGE.

Skyworks products are not intended for use in medical, lifesaving or life-sustaining applications, or other equipment in which the failure of the Skyworks products could lead to personal injury, death, physical or environmental damage. Skyworks customers using or selling Skyworks products for use in such applications do so at their own risk and agree to fully indemnify Skyworks for any damages resulting from such improper use or sale.

Customers are responsible for their products and applications using Skyworks products, which may deviate from published specifications as a result of design defects, errors, or operation of products outside of published parameters or design specifications. Customers should include design and operating safeguards to minimize these and other risks. Skyworks assumes no liability for applications assistance, customer product design, or damage to any equipment resulting from the use of Skyworks products outside of stated published specifications or parameters.

Skyworks, the Skyworks symbol, and “Breakthrough Simplicity” are trademarks or registered trademarks of Skyworks Solutions, Inc., in the United States and other countries. Third-party brands and names are for identification purposes only, and are the property of their respective owners. Additional information, including relevant terms and conditions, posted at www.skyworksinc.com, are incorporated by reference.