

SKiM301TMLI12E4C

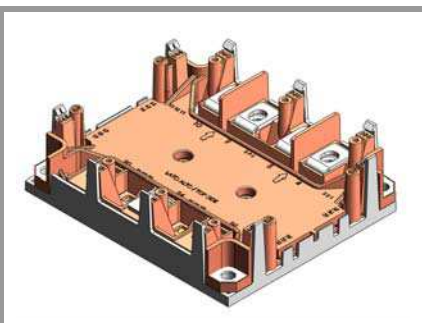

SKiM® 4

Trench IGBT Modules

SKiM301TMLI12E4C

Features

- IGBT 4 Trench Gate Technology
- Solder technology
- $V_{CE(sat)}$ with positive temperature coefficient
- Low inductance case
- Isolated by Al_2O_3 DCB (Direct Copper Bonded) ceramic substrate
- Pressure contact technology for thermal contacts
- Spring contact system to attach driver PCB to the control terminals
- High short circuit capability, self limiting to $6 \times I_C$
- Integrated temperature sensor

Typical Applications*

- Automotive inverter
- High reliability AC inverter wind
- High reliability AC inverter drives

Remarks

- Case temperature limited to $T_s = 125^\circ C$ max; $T_c = T_s$ (for baseplateless modules)
- Recommended $T_{op} = -40 \dots +150^\circ C$

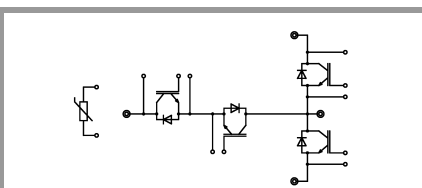

TMLI

Absolute Maximum Ratings				
Symbol	Conditions		Values	Unit
IGBT 1				
V_{CES}	$T_j = 25^\circ C$		1200	V
I_C	$T_j = 150^\circ C$	$T_s = 25^\circ C$	263	A
		$T_s = 70^\circ C$	200	A
I_C	$T_j = 175^\circ C$	$T_s = 25^\circ C$	294	A
		$T_s = 70^\circ C$	237	A
I_{Cnom}			300	A
I_{CRM}	$I_{CRM} = 3 \times I_{Cnom}$		900	A
V_{GES}			-20 ... 20	V
t_{psc}	$V_{CC} = 800 V$ $V_{GE} \leq 15 V$ $V_{CES} \leq 1200 V$	$T_j = 150^\circ C$	10	μs
T_j			-40 ... 175	$^\circ C$

Absolute Maximum Ratings				
Symbol	Conditions		Values	Unit
IGBT 2				
V_{CES}	$T_j = 25^\circ C$		1200	V
I_C	$T_j = 150^\circ C$	$T_s = 25^\circ C$	263	A
		$T_s = 70^\circ C$	200	A
I_C	$T_j = 175^\circ C$	$T_s = 25^\circ C$	294	A
		$T_s = 70^\circ C$	237	A
I_{Cnom}			300	A
I_{CRM}	$I_{CRM} = 3 \times I_{Cnom}$		900	A
V_{GES}			-20 ... 20	V
t_{psc}	$V_{CC} = 800 V$ $V_{GE} \leq 15 V$ $V_{CES} \leq 1200 V$	$T_j = 150^\circ C$	10	μs
T_j			-40 ... 175	$^\circ C$

Absolute Maximum Ratings				
Symbol	Conditions		Values	Unit
Module				
$I_{t(RMS)}$	$T_{terminal} = 80^\circ C,$		400	A
T_{stg}			-40 ... 125	$^\circ C$
V_{isol}	AC sinus 50 Hz, $t = 1 \text{ min}$		2500	V

SKiM301TMLI12E4C

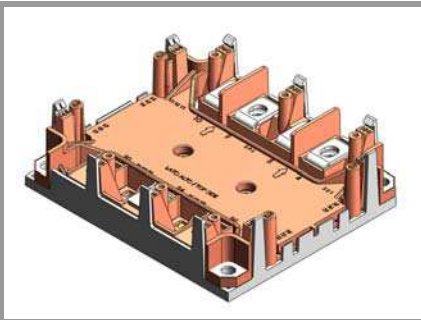

SKiM® 4

Trench IGBT Modules

SKiM301TMLI12E4C

Features

- IGBT 4 Trench Gate Technology
- Solder technology
- $V_{CE(sat)}$ with positive temperature coefficient
- Low inductance case
- Isolated by Al_2O_3 DCB (Direct Copper Bonded) ceramic substrate
- Pressure contact technology for thermal contacts
- Spring contact system to attach driver PCB to the control terminals
- High short circuit capability, self limiting to $6 \times I_C$
- Integrated temperature sensor

Typical Applications*

- Automotive inverter
- High reliability AC inverter wind
- High reliability AC inverter drives

Remarks

- Case temperature limited to $T_s = 125^\circ C$ max; $T_C = T_s$ (for baseplateless modules)
- Recommended $T_{op} = -40 \dots +150^\circ C$

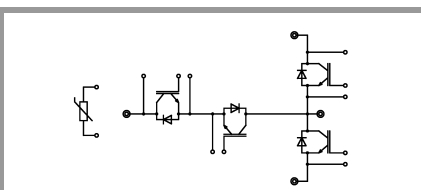

TMLI

Absolute Maximum Ratings				
Symbol	Conditions		Values	Unit
Diode 1				
V_{RRM}	$T_j = 25^\circ C$		1200	V
I_F	$T_j = 175^\circ C$	$T_s = 25^\circ C$	274	A
		$T_s = 70^\circ C$	217	A
I_F	$T_j = 175^\circ C$	$T_s = 25^\circ C$	274	A
		$T_s = 70^\circ C$	217	A
I_{Fnom}			300	A
I_{FRM}	$I_{FRM} = 3 \times I_{Fnom}$		900	A
I_{FSM}	10 ms, sin 180° , $T_j = 150^\circ C$		1485	A
T_j			-40 ... 175	$^\circ C$

Absolute Maximum Ratings				
Symbol	Conditions		Values	Unit
Diode 2				
V_{RRM}	$T_j = 25^\circ C$		1200	V
I_F	$T_j = 175^\circ C$	$T_s = 25^\circ C$	274	A
		$T_s = 70^\circ C$	217	A
I_F	$T_j = 175^\circ C$	$T_s = 25^\circ C$	274	A
		$T_s = 70^\circ C$	217	A
I_{Fnom}			300	A
I_{FRM}	$I_{FRM} = 3 \times I_{Fnom}$		900	A
I_{FSM}	10 ms sin 180°	$T_j = 25^\circ C$	1485	A
		$T_j = 150^\circ C$	1485	A
T_j			-40 ... 175	$^\circ C$

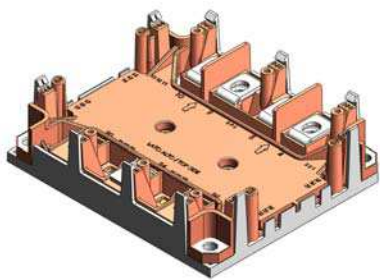

SKiM® 4

Trench IGBT Modules

SKiM301TMLI12E4C

Features

- IGBT 4 Trench Gate Technology
- Solder technology
- $V_{CE(sat)}$ with positive temperature coefficient
- Low inductance case
- Isolated by Al_2O_3 DCB (Direct Copper Bonded) ceramic substrate
- Pressure contact technology for thermal contacts
- Spring contact system to attach driver PCB to the control terminals
- High short circuit capability, self limiting to $6 \times I_C$
- Integrated temperature sensor

Typical Applications*

- Automotive inverter
- High reliability AC inverter wind
- High reliability AC inverter drives

Remarks

- Case temperature limited to $T_s = 125^\circ C$ max; $T_C = T_s$ (for baseplateless modules)
- Recommended $T_{op} = -40 \dots +150^\circ C$

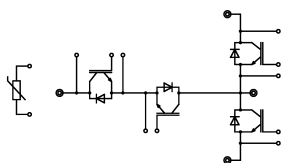

TMI

Characteristics					
Symbol	Conditions	min.	typ.	max.	Unit
IGBT 1					
$V_{CE(sat)}$	$I_C = 300 A$ $V_{GE} = 15 V$ chipllevel	$T_j = 25^\circ C$	1.80	2.05	V
		$T_j = 150^\circ C$	2.20	2.40	V
V_{CE0}	chipllevel	$T_j = 25^\circ C$	0.8	0.9	V
		$T_j = 150^\circ C$	0.7	0.8	V
r_{CE}	$V_{GE} = 15 V$ chipllevel	$T_j = 25^\circ C$	3.3	3.8	m Ω
		$T_j = 150^\circ C$	5.0	5.3	m Ω
$V_{GE(th)}$	$V_{GE} = V_{CE} V, I_C = 11.4 mA$	5	5.8	6.5	V
I_{CES}	$V_{GE} = 0 V$ $V_{CE} = 1200 V$	$T_j = 25^\circ C$			mA
					mA
C_{ies}	$V_{CE} = 25 V$ $V_{GE} = 0 V$	$f = 1 MHz$	18.45		nF
C_{oes}		$f = 1 MHz$	1.215		nF
C_{res}		$f = 1 MHz$	1.035		nF
Q_G	- 8 V...+ 15 V		1695		nC
R_{Gint}	$T_j = 25^\circ C$		2.50		Ω
$t_{d(on)}$	$V_{CE} = 3 V$ $I_C = 300 A$	$T_j = 150^\circ C$	217.9		ns
t_r	$R_{G on} = 2.7 \Omega$ $R_{G off} = 2.7 \Omega$	$T_j = 150^\circ C$	69.43		ns
E_{on}	$R_{G on} = 2.7 \Omega$ $R_{G off} = 2.7 \Omega$	$T_j = 150^\circ C$	6.619		mJ
$t_{d(off)}$	$di/dt_{on} = 5626 A/\mu s$	$T_j = 150^\circ C$	355.5		ns
t_f	$di/dt_{off} = 2636 A/\mu s$	$T_j = 150^\circ C$	91.3		ns
E_{off}	$V_{GE neg} = -15 V$ $V_{GE pos} = 15 V$	$T_j = 150^\circ C$	19.376		mJ
$R_{th(j-s)}$	per IGBT		0.21		K/W

Characteristics					
Symbol	Conditions	min.	typ.	max.	Unit
IGBT 2					
$V_{CE(sat)}$	$I_C = 300 A$ $V_{GE} = 15 V$ chipllevel	$T_j = 25^\circ C$	1.8	2.05	V
		$T_j = 150^\circ C$	2.2	2.4	V
V_{CE0}	chipllevel	$T_j = 25^\circ C$	0.8	0.9	V
		$T_j = 150^\circ C$	0.7	0.8	V
r_{CE}	$V_{GE} = 15 V$ chipllevel	$T_j = 25^\circ C$	3.3	3.8	m Ω
		$T_j = 150^\circ C$	5.0	5.3	m Ω
$V_{GE(th)}$	$V_{GE} = V_{CE} V, I_C = 11.4 mA$	5	5.8	6.5	V
I_{CES}	$V_{GE} = 0 V$ $V_{CE} = 1200 V$	$T_j = 25^\circ C$			mA
		$T_j = 150^\circ C$			mA
C_{ies}	$V_{CE} = 25 V$ $V_{GE} = 0 V$	$f = 1 MHz$	18.45		nF
C_{oes}		$f = 1 MHz$	1.215		nF
C_{res}		$f = 1 MHz$	1.035		nF
Q_G	- 8 V...+ 15 V		1695		nC
R_{Gint}	$T_j = 25^\circ C$		2.50		Ω
$t_{d(on)}$	$V_{CE} = 300 V$ $I_C = 300 A$	$T_j = 150^\circ C$	217.9		ns
t_r	$R_{G on} = 2.7 \Omega$ $R_{G off} = 2.7 \Omega$	$T_j = 150^\circ C$	69.43		ns
E_{on}	$R_{G on} = 2.7 \Omega$ $R_{G off} = 2.7 \Omega$	$T_j = 150^\circ C$	6.619		mJ
$t_{d(off)}$	$di/dt_{on} = 5626 A/\mu s$	$T_j = 150^\circ C$	355.5		ns
t_f	$di/dt_{off} = 2336 A/\mu s$	$T_j = 150^\circ C$	91.3		ns
E_{off}	$V_{GE neg} = -15 V$ $V_{GE pos} = 15 V$	$T_j = 150^\circ C$	19.376		mJ
$R_{th(j-s)}$	per IGBT		0.21		K/W

SKiM301TMLI12E4C

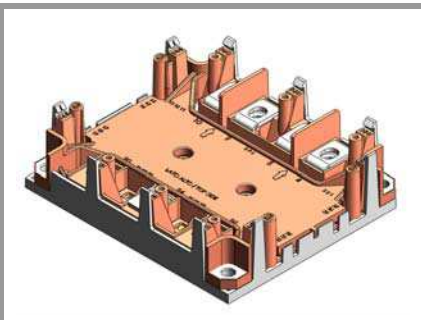

SKiM® 4

Trench IGBT Modules

SKiM301TMLI12E4C

Features

- IGBT 4 Trench Gate Technology
- Solder technology
- $V_{CE(sat)}$ with positive temperature coefficient
- Low inductance case
- Isolated by Al_2O_3 DCB (Direct Copper Bonded) ceramic substrate
- Pressure contact technology for thermal contacts
- Spring contact system to attach driver PCB to the control terminals
- High short circuit capability, self limiting to $6 \times I_C$
- Integrated temperature sensor

Typical Applications*

- Automotive inverter
- High reliability AC inverter wind
- High reliability AC inverter drives

Remarks

- Case temperature limited to $T_s = 125^\circ C$ max; $T_C = T_s$ (for baseplateless modules)
- Recommended $T_{op} = -40 \dots +150^\circ C$

Characteristics						
Symbol	Conditions		min.	typ.	max.	Unit
Diode 1						
$V_F = V_{EC}$	$I_F = 300 \text{ A}$ $V_{GE} = 15 \text{ V}$ chipelevel	$T_j = 25^\circ C$		2.20	2.52	V
		$T_j = 150^\circ C$		2.15	2.47	V
V_{F0}	chipelevel	$T_j = 25^\circ C$	1.1	1.3	1.5	V
		$T_j = 150^\circ C$	0.7	0.9	1.1	V
r_F	chipelevel	$T_j = 25^\circ C$	2.7	3.0	3.4	m Ω
		$T_j = 150^\circ C$	3.5	4.2	4.6	m Ω
I_{RRM}	$I_F = 300 \text{ A}$	$T_j = 150^\circ C$		132.43		A
Q_{rr}		$T_j = 150^\circ C$		21.47		μC
E_{rr}		$T_j = 150^\circ C$		1.79		mJ
$R_{th(j-s)}$	per DIODE			0.25		K/W

Characteristics						
Symbol	Conditions		min.	typ.	max.	Unit
Diode 2						
$V_F = V_{EC}$	$I_F = 300 \text{ A}$ $V_{GE} = 15 \text{ V}$ chipelevel	$T_j = 25^\circ C$		2.2	2.50	V
		$T_j = 150^\circ C$		2.15	2.47	V
V_{F0}	chipelevel	$T_j = 25^\circ C$	1.1	1.3	1.5	V
		$T_j = 150^\circ C$	0.7	0.9	1.1	V
r_F	chipelevel	$T_j = 25^\circ C$	2.7	3.0	3.4	m Ω
		$T_j = 150^\circ C$	3.5	4.2	4.6	m Ω
I_{RRM}	$I_F = 300 \text{ A}$	$T_j = 150^\circ C$		132.43		A
Q_{rr}		$T_j = 150^\circ C$		21.47		μC
E_{rr}		$T_j = 150^\circ C$		1.79		mJ
$R_{th(j-s)}$	per DIODE			0.25		K/W

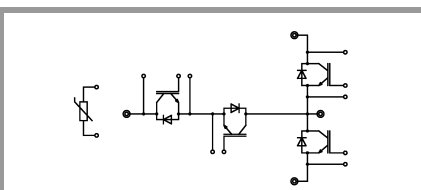

TMLI

SKiM301TMLI12E4C

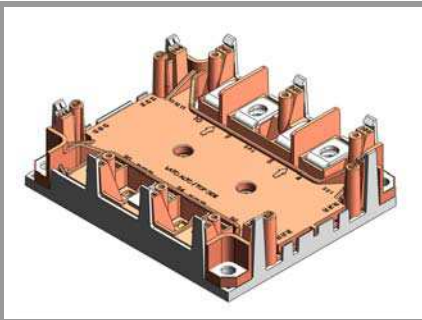

SKiM® 4

Trench IGBT Modules

SKiM301TMLI12E4C

Features

- IGBT 4 Trench Gate Technology
- Solder technology
- $V_{CE(sat)}$ with positive temperature coefficient
- Low inductance case
- Isolated by Al_2O_3 DCB (Direct Copper Bonded) ceramic substrate
- Pressure contact technology for thermal contacts
- Spring contact system to attach driver PCB to the control terminals
- High short circuit capability, self limiting to $6 \times I_C$
- Integrated temperature sensor

Typical Applications*

- Automotive inverter
- High reliability AC inverter wind
- High reliability AC inverter drives

Remarks

- Case temperature limited to $T_s = 125^\circ C$ max; $T_C = T_s$ (for baseplateless modules)
- Recommended $T_{op} = -40 \dots +150^\circ C$

Characteristics						
Symbol	Conditions		min.	typ.	max.	Unit
Module						
L_{CE}				18		nH
$R_{CC'+EE'}$	terminal-chip	$T_s = 25^\circ C$		1.35		$m\Omega$
		$T_s = 125^\circ C$		1.75		$m\Omega$
$R_{th(c-s)}$	per module					K/W
M_s	to heat sink (M5)		2		3	Nm
M_t		to terminals M6	4		5	Nm
						Nm
w				317		g

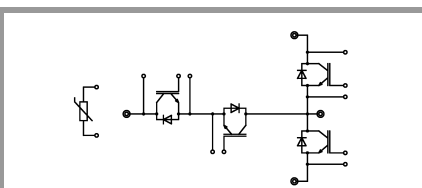

TMLI

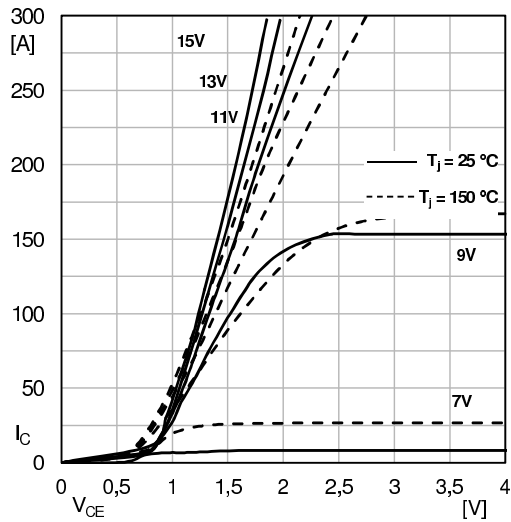

Fig. 1: Typ. output characteristic, inclusive $R_{CC'+EE'}$

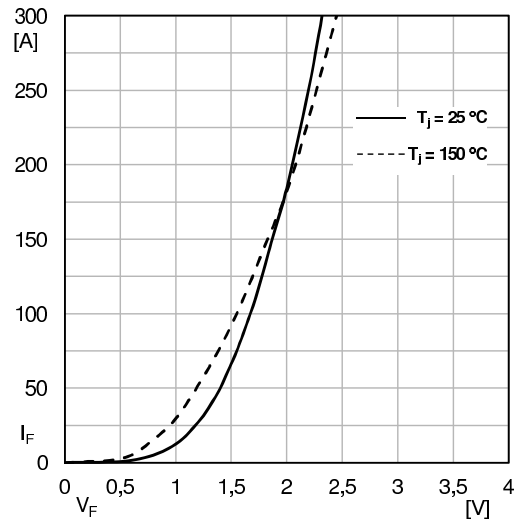

Fig. 2: Typ. Diode 1 output characteristics

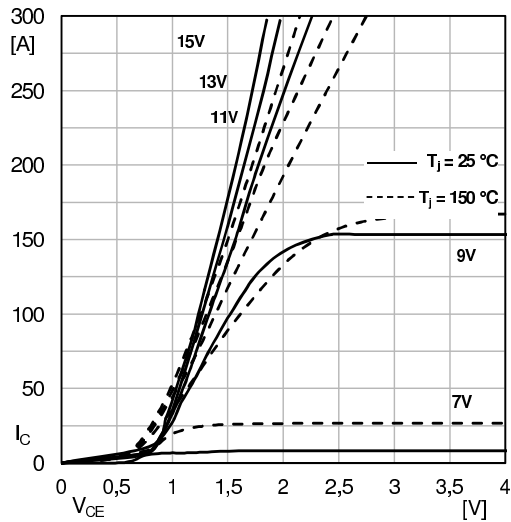

Fig. 3: Typ. IGBT 2 output characteristic, inclusive $R_{CC'+EE'}$

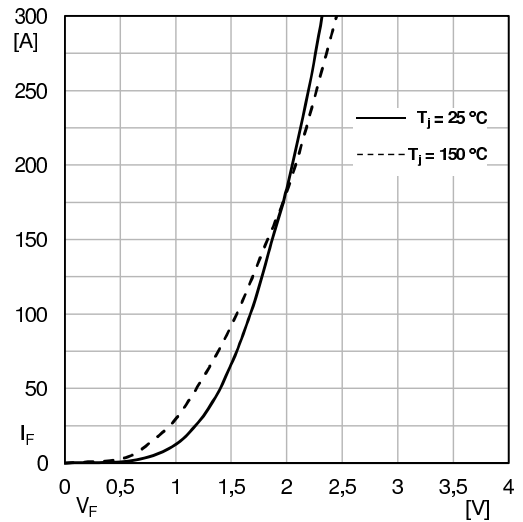

Fig. 4: Typ. Diode 2 output characteristic

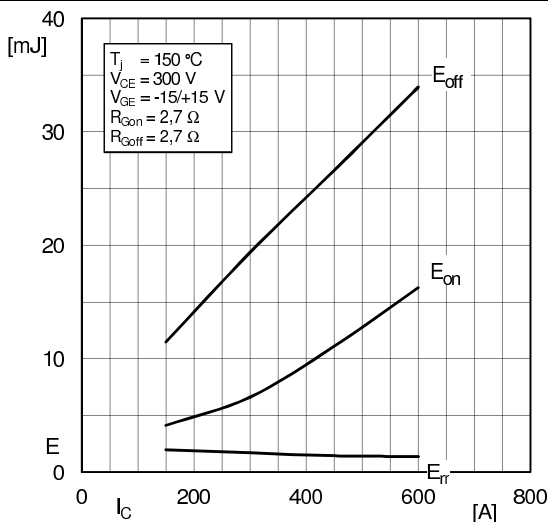

Fig. 5: Typ. IGBT 1 turn-on /-off energy = $f(I_c)$

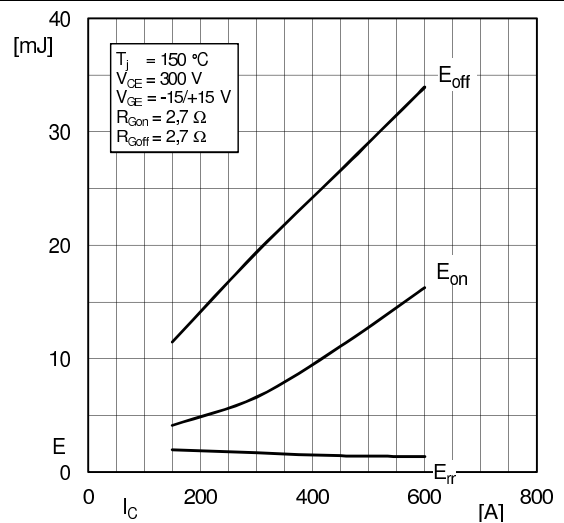

Fig. 6: Typ. IGBT 2 turn-on /-off energy = $f(I_c)$

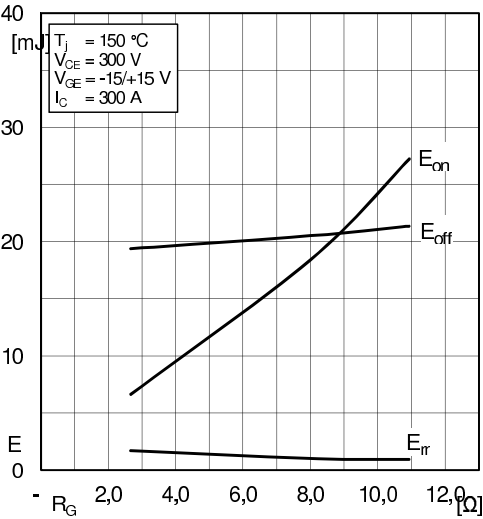

Fig. 7: Typ. IGBT 1 turn-on /-off energy = f (R_G)

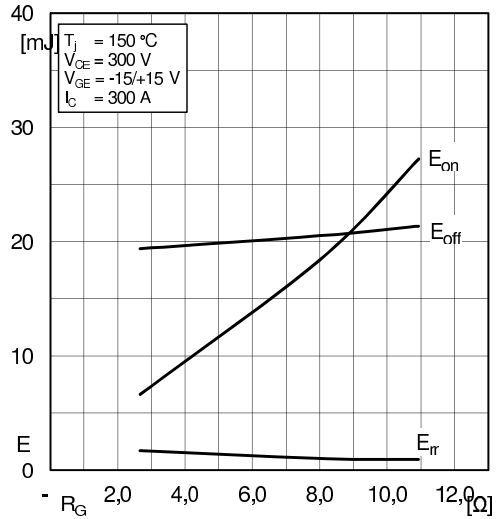

Fig. 8: Typ. IGBT 2 turn-on /-off energy = f (R_G)

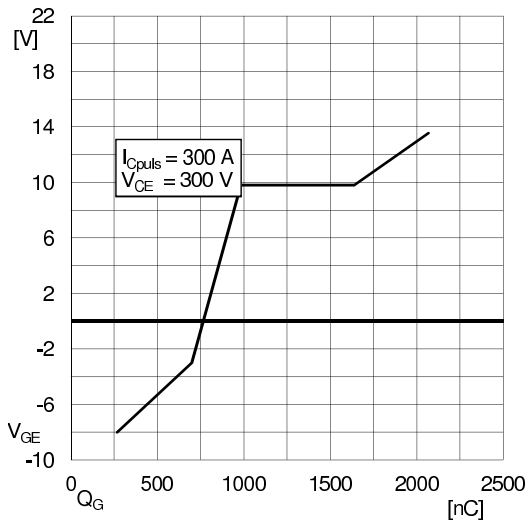

Fig. 9: Typ. IGBT 1 gate charge characteristic

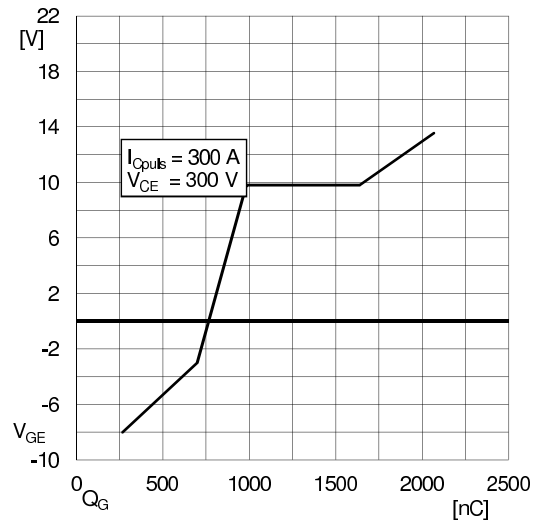

Fig. 10: Typ. IGBT 2 gate charge characteristic

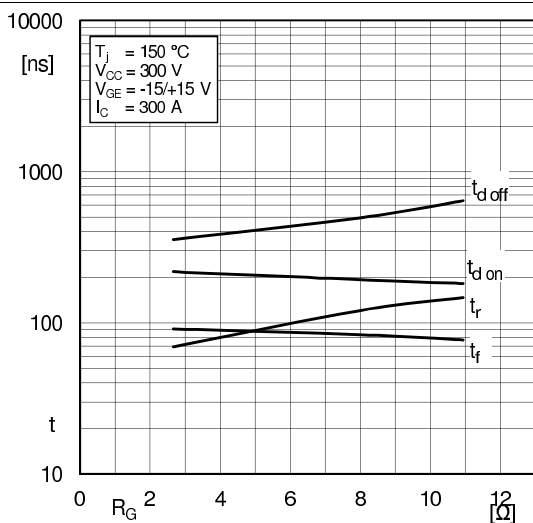

Fig. 11: Typ. IGBT 1 switching times vs. gate resistor R_G

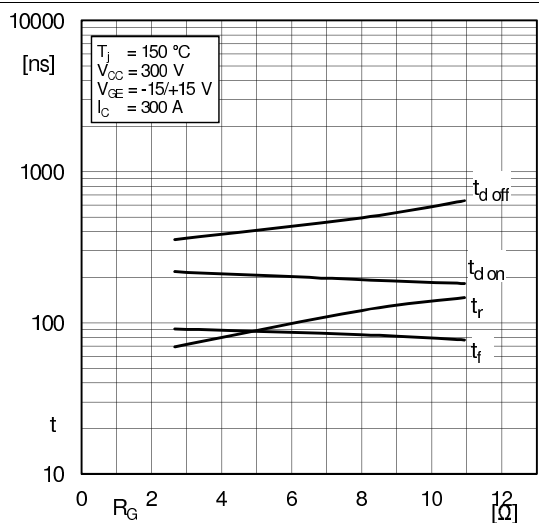

Fig. 12: Typ. IGBT 2 switching times vs. gate resistor R_G

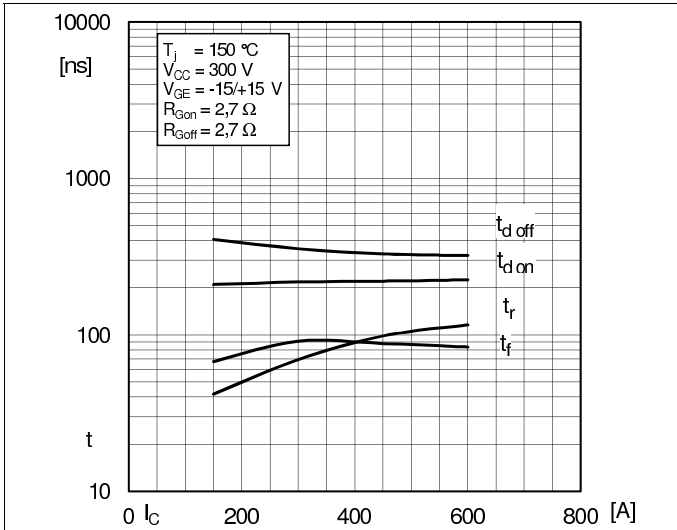

Fig. 13: Typ. IGBT 1 switching times vs. I_C

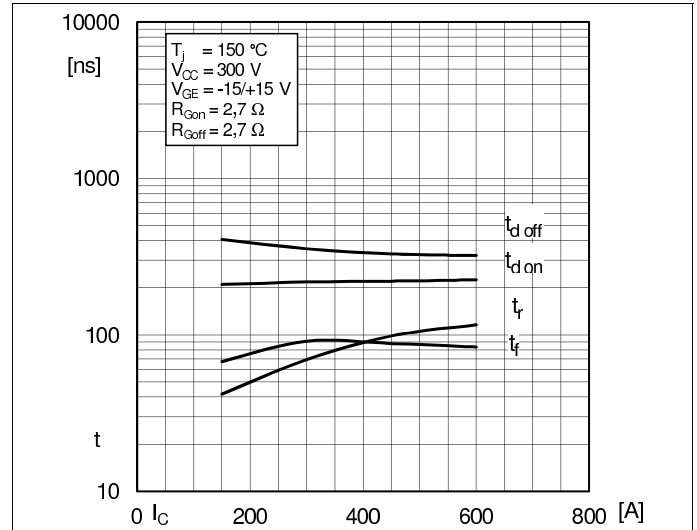

Fig. 14: Typ. IGBT 2 switching times vs. I_C

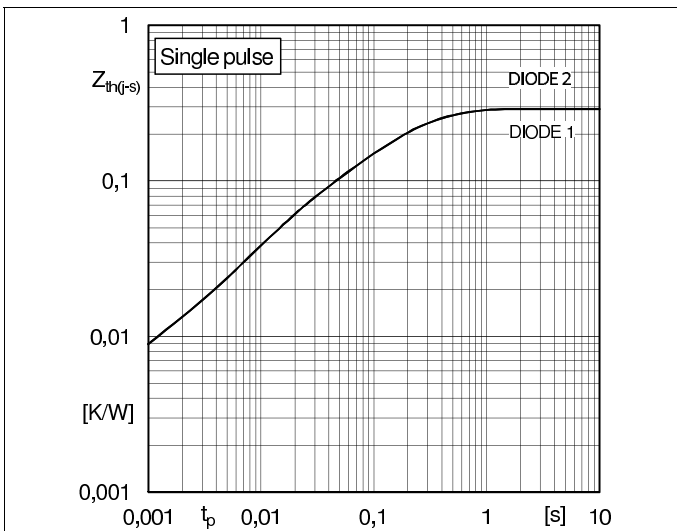

Fig. 15: Typ. DIODEs transient thermal impedance

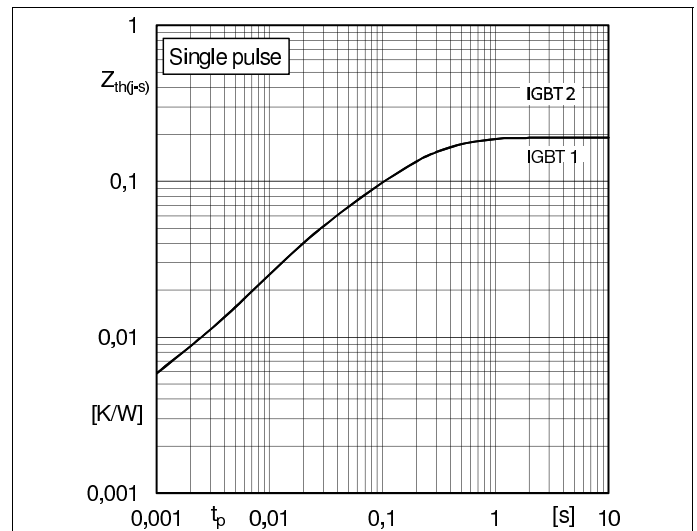
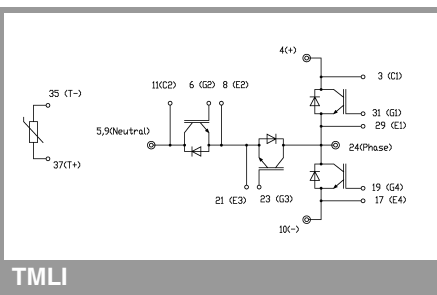
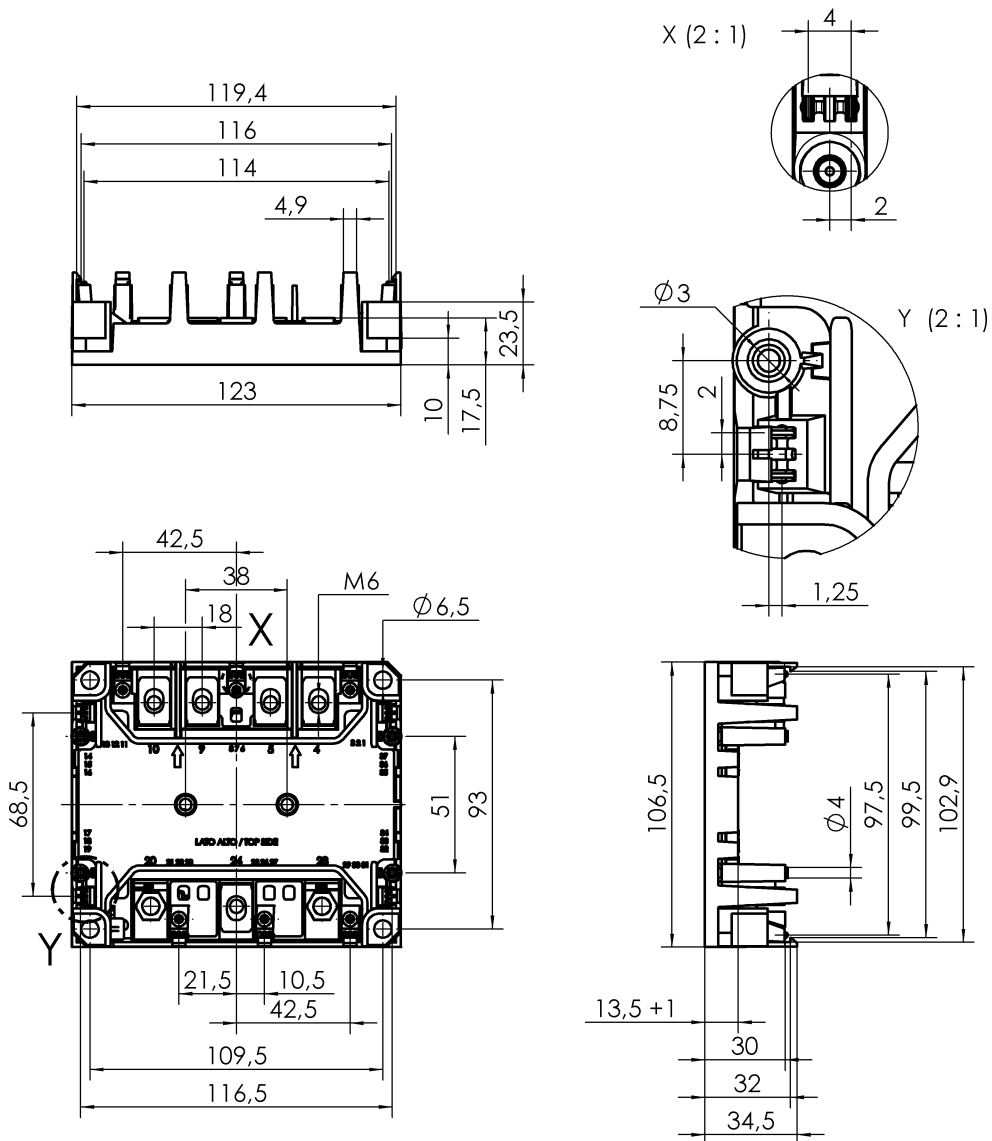

Fig. 16: Typ. IGBTs transient thermal impedance

SKiM301TMLI12E4C



TM LI

This is an electrostatic discharge sensitive device (ESDS), international standard IEC 60747-1, Chapter IX

* The specifications of our components may not be considered as an assurance of component characteristics. Components have to be tested for the respective application. Adjustments may be necessary. The use of SEMIKRON products in life support appliances and systems is subject to prior specification and written approval by SEMIKRON. We therefore strongly recommend prior consultation of our staff.