

FAST RECOVER DIODE

Features

- 600V,30A
- Soft Recovery
- Operation Temperature < 175°C
- Planar Construction

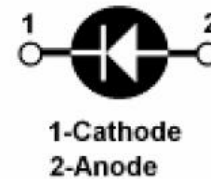
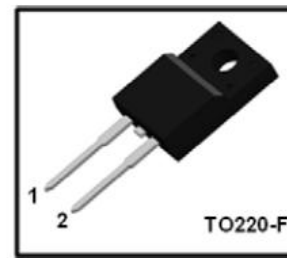

Applications

- Freewheeling, Snubber, Clamp
- Inversion Welder
- PFC
- Plating Power Supply
- Ultrasonic Cleaner and Welder
- Converter & Chopper
- UPS

Absolute Maximum Ratings

Symbol	Parameter	Value	Units
V_R	Maximum D.C. Reverse Voltage	600	V
V_{RRM}	Maximum Repetitive Reverse Voltage	600	V
$I_{F(AV)}$	Diode Continuous Forward Current ($T_C=100^\circ\text{C}$)	30	A
I_{FRMS}	RMS Forward Current ($T_C=100^\circ\text{C}$)	42	A
I_{FSM}	Non-Repetitive Surge Forward Current	300	A
P_D	Power Dissipation	104	W
T_J	Operating Junction Temperature Range	-55 to +175	°C
T_{STG}	Storage Temperature Range	-55 to +175	°C
R_{thJC}	Thermal Resistance	1.2	°C/W

Electrical Characteristics ($T_C=25^\circ\text{C}$ unless otherwise noted)

Symbol	Parameter	Test Conditions	Min.	Typ.	Max.	Units
V_F	Diode Forward Voltage	$I_F=15\text{A } T_C=25^\circ\text{C}$		1.2	1.6	V
	Diode Forward Voltage	$I_F=15\text{A } T_C=125^\circ\text{C}$		1.1	1.5	V
IR	Instantaneous reverse current	$V_R=600\text{V}$			10	μA
I_{RRM}	Diode peak Reverse Recovery Current	$I_F=1\text{A}$		1.6		A
t_{rr}	Diode Reverse Recovery Time	$di_F/dt=200\text{A}/\mu\text{s}$		45		ns
Q_{RR}	Diode Reverse Recovery Charge	$V_R=30\text{V}$		40		nC
I_{RRM}	Diode peak Reverse Recovery Current	$I_F=15\text{A}$,		8.8		A
t_{rr}	Diode Reverse Recovery Time	$di_F/dt=200\text{A}/\mu\text{s}$		120		ns
Q_{RR}	Diode Reverse Recovery Charge	$V_R=300\text{V}$		570		nC

Fig.1 Forward Current vs Forward Voltage

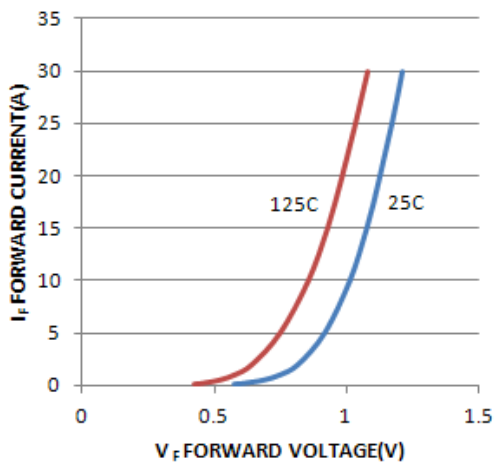

Fig.2 Reverse Current vs Reverse Voltage

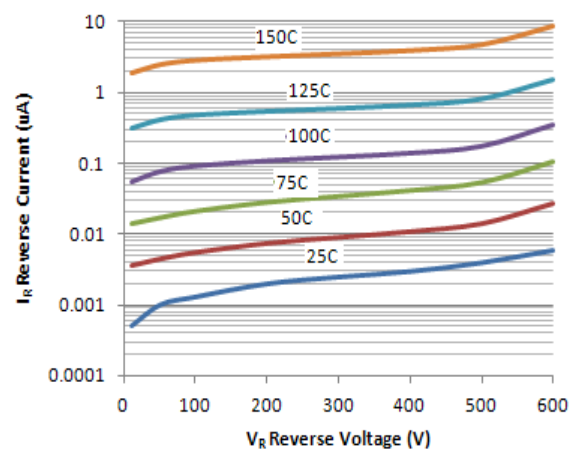

Fig.3 t_{rr} Test Circuit

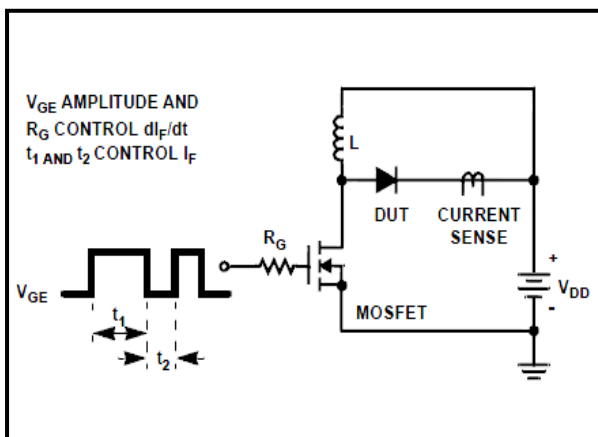

Fig.4 t_{rr} Waveforms and Definitions

