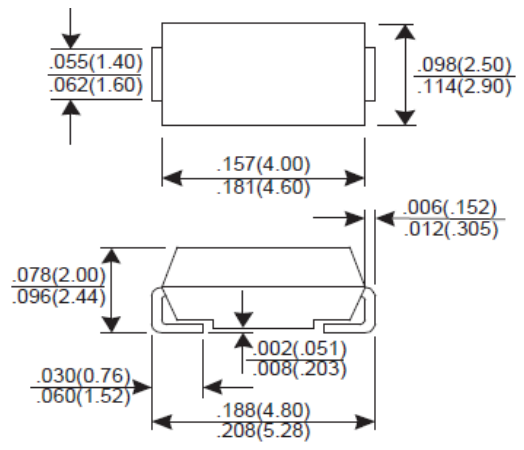

SL32A THRU SLL34A

Surface Mount Schottky Barrier Rectifier

<p>Features</p> <ul style="list-style-type: none"> • Low forward voltage drop • High current capability • High reliability • High surge current capability <p>Mechanical Data</p> <ul style="list-style-type: none"> • Case: Molded plastic SMA/DO-214AC • Epoxy: UL 94V-0 rate flame retardant • Terminals: Solderable per MIL-STD-750 method 2026 • Polarity: Color band denotes cathode end • Mounting position: Any • Weight: 0.064 grams 	<p>Voltage Range 20V-40V / Current 3.0 Ampere SMA/DO-214AC</p>  <p>Dimensions in inches and (millimeters)</p>
---	---

MAXIMUM RATINGS AND ELECTRICAL CHARACTERISTICS

Rating at 25°C ambient temperature unless otherwise specified.

Single phase, half wave, 60Hz, resistive or inductive load.

For capacitive load, derate current by 20%.

PARAMETER	SYMBOL	SL32A	SLL32A	SL34A	SLL34A	UNIT
Max. Recurrent Peak Reverse Voltage	VRRM	20		40		V
Max. RMS Voltage	VRMS	14		28		V
Max. DC Blocking Voltage	VDC	20		40		V
Max. Average Forward Rectified Current T _L =105°C	I _{F(AV)}	3.0				A
Peak Forward Surge Current, 8.3ms single half sine-wave superimposed on rated load (JEDEC method)	I _{FSM}	80				A
Max. Instantaneous Forward Voltage: @3.0A	V _F	0.42	0.38	0.45	0.40	V
Max. DC Reverse Current @T _J =25°C At Rated DC Blocking Voltage @T _J =125°C	I _R	1.5 35				mA
Maximum Reverse Recovery Time (Note 1)	C _J	250				pF
Operating Junction and Storage Temperature Range	T _J , T _{STG}	-55 to +125 / -55 to +150				°C

NOTES : (1) Measured at 1.0 MHz and applied reverse voltage of 4.0 Volts DC.

(2) Pulse test : 300us pulse width, 1% duty cycle

RATINGS AND CHARACTERISTIC CURVES SL32A THRU SLL34A

FIG. 1 - FORWARD CURRENT DERATING CURVE

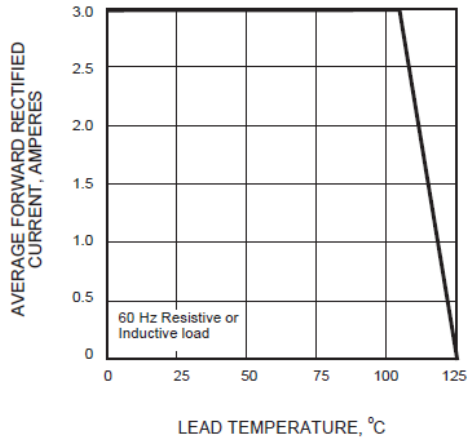

FIG. 2 - MAXIMUM NON-REPETITIVE PEAK FORWARD SURGE CURRENT

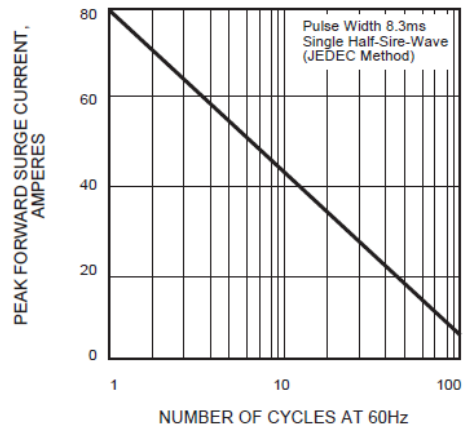

FIG. 3 - TYPICAL INSTANTANEOUS FORWARD CHARACTERISTICS

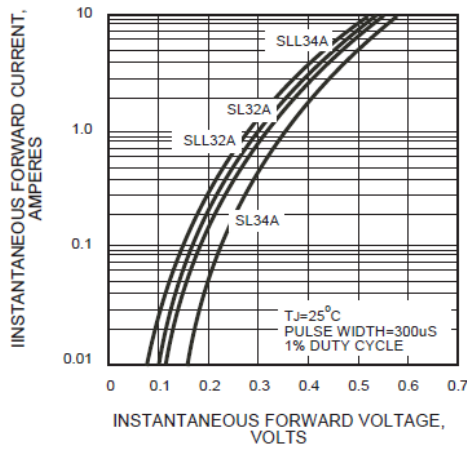

FIG. 4 - TYPICAL REVERSE CHARACTERISTICS

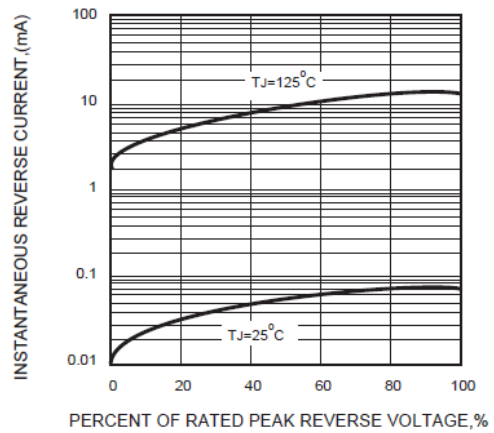

FIG. 5 - TYPICAL JUNCTION CAPACITANCE

