

Schottky Barrier Rectifiers

SL32BF--SL345BF

Features

- Metal silicon junction, majority carrier conduction
- High surge capability
- High temperature soldering guaranteed:
260°C/10 seconds
- High current capability, low forward voltage drop
- RoHS Compliant

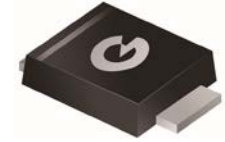

Mechanical Data

- Case: SMBF molded plastic
- Molding compound, UL flammability classification rating 94V-0
- Terminals: Solder plated, solderable per MIL-STD-202, Method 208
- Polarity: Color band denotes cathode end

Maximum Ratings (@T_A = 25°C unless otherwise specified)

Characteristic	Symbol	SL32BF	SL33BF	SL34BF	SL345BF	Units
Peak repetitive reverse voltage	V _{RRM}	20	30	40	45	V
RMS reverse voltage	V _{RMS}	14	21	28	31.5	V
DC blocking voltage	V _{DC}	20	30	40	45	V
Maximum average forward output current	I _{F(AV)}	3.0				A
Peak forward surge current, 8.3ms single half-sine-wave	I _{FSM}	80				A

Thermal Characteristics

Parameter	Symbol	SL32BF	SL33BF	SL34BF	SL345BF	Units
Typical thermal resistance (Note 1)	R _{θJA}	65				°C/W
	R _{θJC}	16				
	R _{θJL}	15				
Operating junction temperature range	T _J	- 55 ---- + 125				°C
Storage temperature range	T _{STG}	- 55 ---- + 150				°C

Note:

1. Device mounted on PCB with 10 mm x 20 mm x 0.1mm copper pad areas

Schottky Barrier Rectifiers

SL32BF--SL345BF

Electrical Characteristics (@T_A = 25°C unless otherwise specified)

Parameter	Symbol	Test conditions		Typ.	Max.	Units
Maximum instantaneous forward voltage(Note 1)	V _F	I _F =3.0A	@T _A =25°C	--	0.45	V
Maximum Reverse current (Note 2)	I _R	Rated V _R ,	@T _J =25°C	--	500	μ A
			@T _J =100°C	--	40	m A

Note:

- 1.Pulse test: 300us pulse width, 1 % duty cycle
- 2.Pulse test: Pulse width 40ms

Schottky Barrier Rectifiers

SL32BF--SL345BF

Ratings and Characteristic Curves ($T_A=25^{\circ}\text{C}$ unless otherwise noted)

Fig.1-Forward Current Derating Curve

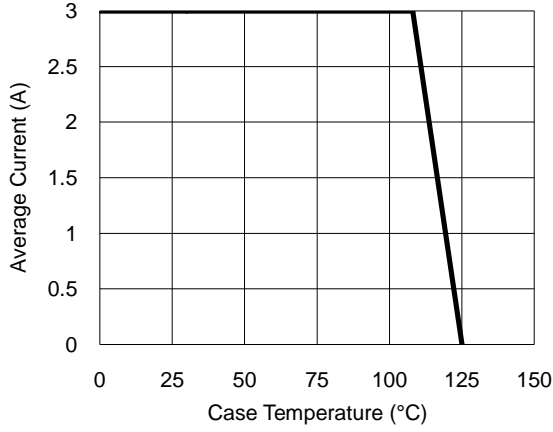

Fig.2- Surge Current Derating Curve

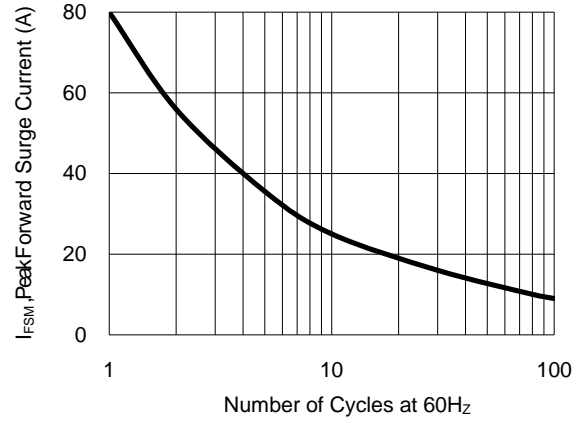

Fig.3- Typical Forward Voltage Characteristic

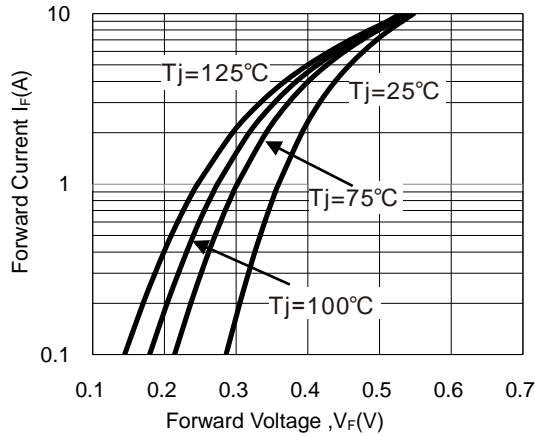
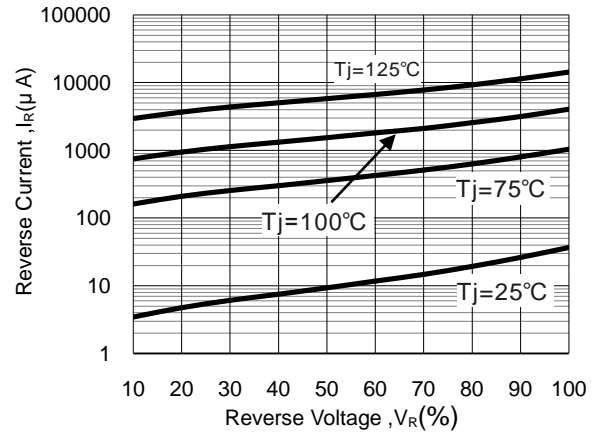

Fig.4- Typical Reverse Characteristic



Schottky Barrier Rectifiers

SL32BF--SL345BF

Package Outline Dimensions(unit:mm)

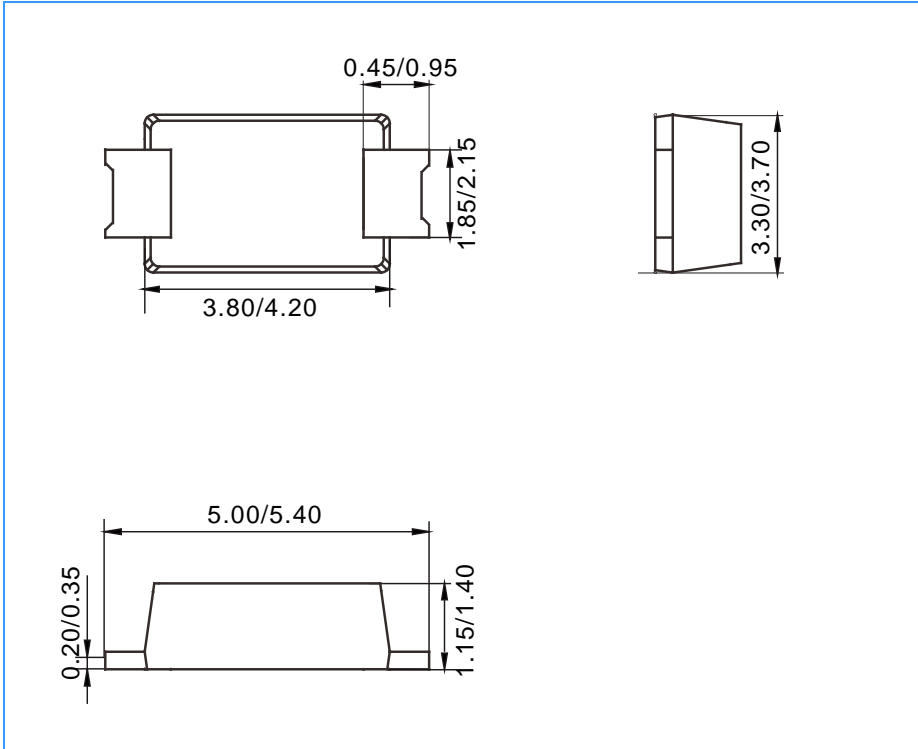

Mounting Pad Layout(unit:mm)

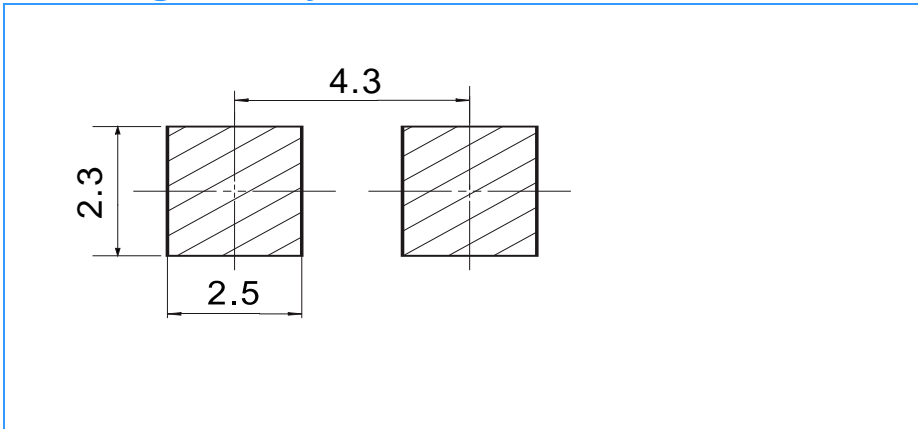

Ordering Information

Part No.	Marking	Package	Shipping
SL32BF	SL32BF	SMBF	4000/ Tape&Reel
SL33BF	SL33BF	SMBF	4000/ Tape&Reel
SL34BF	SL34BF	SMBF	4000/ Tape&Reel
SL345BF	SL345BF	SMBF	4000/ Tape&Reel