

Schottky Barrier Rectifiers

SL58F--SL510F

Features

- Metal silicon junction, majority carrier conduction
- High surge capability
- High temperature soldering guaranteed:
260°C/10 seconds
- High current capability, low forward voltage drop
- RoHS Compliant



Mechanical Data

- Case: SMAF molded plastic
- Molding compound, UL flammability classification rating 94V-0
- Terminals: Solder plated, solderable per MIL- STD-202, Method 208
- Polarity: Color band denotes cathode end

Maximum Ratings (@T_A = 25°C unless otherwise specified)

Characteristic	Symbol	SL58F	SL59F	SL510F	Units
Peak repetitive reverse voltage	V _{RRM}	80	90	100	V
RMS reverse voltage	V _{RMS}	56	63	70	V
DC blocking voltage	V _{DC}	80	90	100	V
Maximum average forward output current	I _{F(AV)}	5.0			A
Peak forward surge current, 8.3ms single half-sine-wave	I _{FSM}	150			A

Thermal Characteristics

Parameter	Symbol	SL58F	SL59F	SL510F	Units
Typical thermal resistance (Note 1)	R _{θJA}	78			°C/W
	R _{θJC}	18			
	R _{θJL}	20			
Operating junction temperature range	T _J	- 55 ---- + 150			°C
Storage temperature range	T _{STG}	- 55 ---- + 150			°C

Note:

1. Device mounted on PCB with 10 mm x 20 mm x 0.1mm copper pad areas

Schottky Barrier Rectifiers

SL58F--SL510F

Electrical Characteristics (@T_A = 25°C unless otherwise specified)

Parameter	Symbol	Test conditions		Typ.	Max.	Units
Maximum instantaneous forward voltage	V _F	I _F =5.0A	@T _A =25°C	--	0.77	V
Maximum Reverse current	I _R	Rated V _R ,	@T _A =25°C	--	250	μ A
			@T _A =100°C	--	20	m A

Schottky Barrier Rectifiers

SL58F--SL510F

Ratings and Characteristic Curves ($T_A=25^\circ\text{C}$ unless otherwise noted)

Fig.1-Forward Current Derating Curve

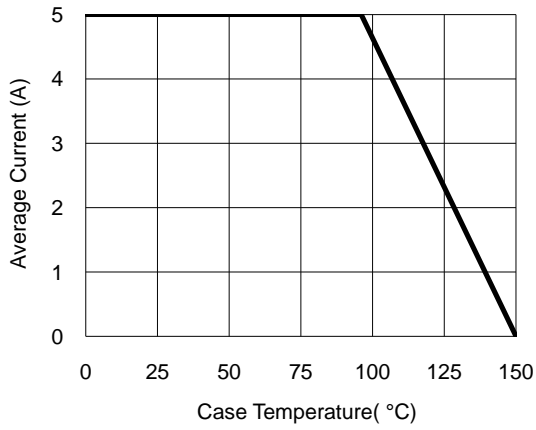

Fig.2- Surge Current Derating Curve

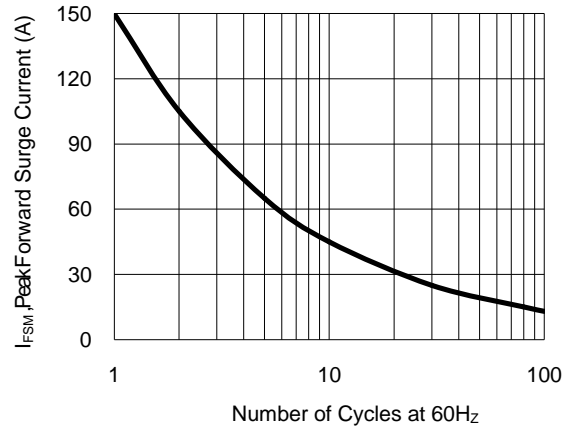

Fig.3- Typical Forward Voltage Characteristic

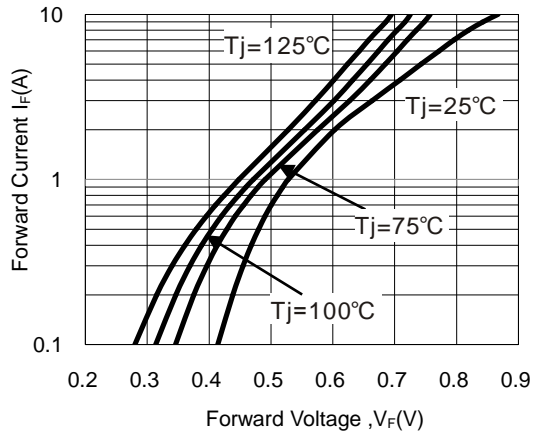
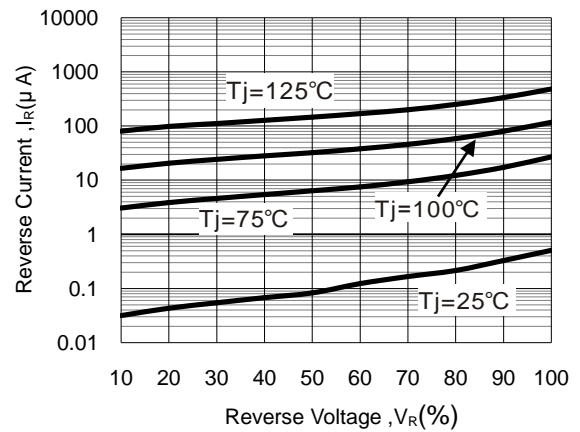

Fig.4- Typical Reverse Characteristic



Schottky Barrier Rectifiers

SL58F--SL510F

Package Outline Dimensions(unit:mm)

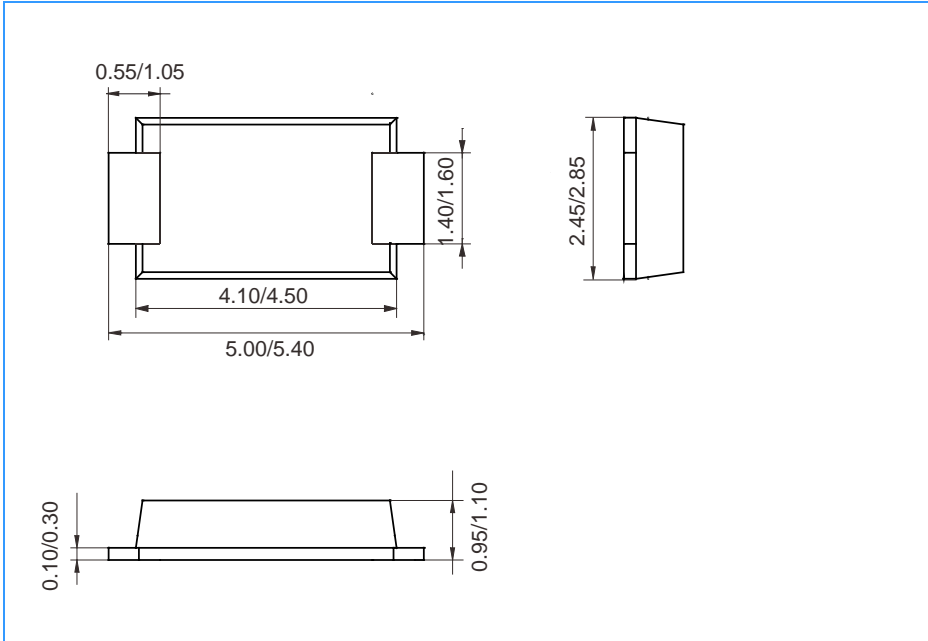

Mounting Pad Layout(unit:mm)

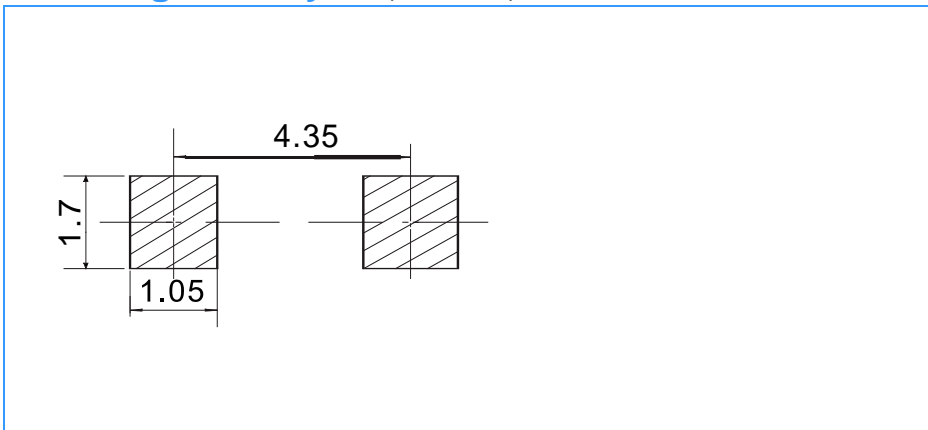

Ordering Information

Part No.	Marking	Package	Shipping
SL58F	SL58F	SMAF	10000/ Tape&Reel
SL59F	SL59F	SMAF	10000/ Tape&Reel
SL510F	SL510F	SMAF	10000/ Tape&Reel