

FAST RECOVER DIODE

Features

- 300V,60A
- Soft Recovery
- Operation Temperature < 150°C
- Planar Construction

Applications

- Freewheeling, Snubber, Clamp
- Inversion Welder
- PFC
- Plating Power Supply
- Ultrasonic Cleaner and Welder
- Converter & Chopper
- UPS

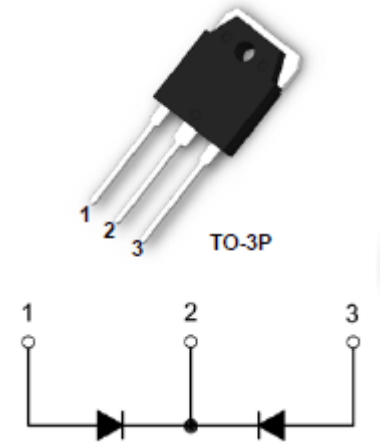

Absolute Maximum Ratings

Symbol	Parameter	Value	Units
V_R	Maximum D.C. Reverse Voltage	300	V
V_{RRM}	Maximum Repetitive Reverse Voltage	300	V
$I_{F(AV)}$	Continuous Forward Current Per Diode ($T_C=100^\circ\text{C}$)	30	A
	Continuous Forward Current Per Package($T_C=100^\circ\text{C}$)	60	A
I_{FRMS}	RMS Forward Current ($T_C=100^\circ\text{C}$)	42	A
I_{FSM}	Non-Repetitive Surge Forward Current	300	A
P_D	Power Dissipation	156	W
T_J	Operating Junction Temperature Range	-55 to +175	°C
T_{STG}	Storage Temperature Range	-55 to +175	°C
R_{thJC}	Thermal Resistance	0.8	°C/W

Electrical Characteristics ($T_C=25^\circ\text{C}$ unless otherwise noted)

Symbol	Parameter	Test Conditions	Min.	Typ.	Max.	Units
V_F	Diode Forward Voltage	$I_F=30\text{A } T_C=25^\circ\text{C}$		0.95	1.2	V
	Diode Forward Voltage	$I_F=30\text{A } T_C=125^\circ\text{C}$		0.8	1.1	V
IR	Instantaneous reverse current	$V_R=300\text{V}$			10	μA
I_{RRM}	Diode peak Reverse Recovery Current	$I_F=1\text{A}$		1.8		A
t_{rr}	Diode Reverse Recovery Time	$di_F/dt=200\text{A}/\mu\text{s}$		50		ns
Q_{RR}	Diode Reverse Recovery Charge	$V_R=30\text{V}$		50		nC
I_{RRM}	Diode peak Reverse Recovery Current	$I_F=30\text{A},$		6.7		A
t_{rr}	Diode Reverse Recovery Time	$di_F/dt=200\text{A}/\mu\text{s}$		70		ns
Q_{RR}	Diode Reverse Recovery Charge	$V_R=150\text{V}$		270		nC

Fig.1 Forward Current vs Forward Voltage

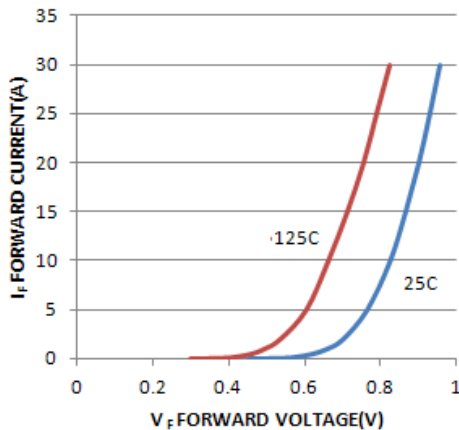

Fig.2 Reverse Current vs Reverse Voltage

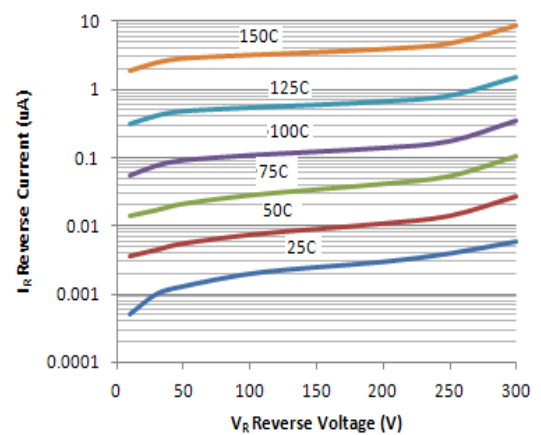

Fig.3 t_{rr} Test Circuit

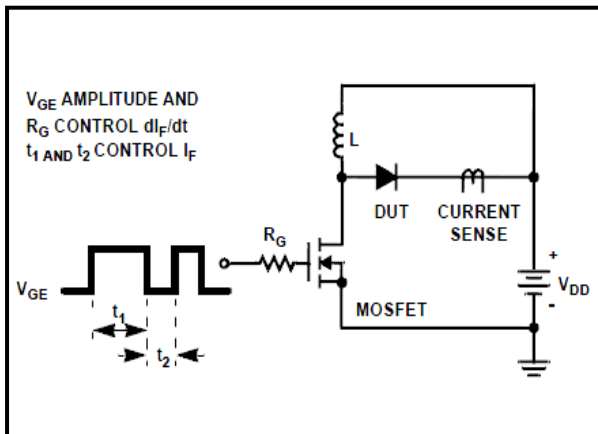

Fig.4 t_{rr} Waveforms and Definitions

