

SL621

AGC GENERATOR

The SL621C is an AGC generator designed specifically for use in SSB receivers in conjunction with the SL610C, SL611C and SL612C RF and IF amplifiers. In common with other advanced systems it generates a suitable AGC voltage directly from the detected audio waveform, provides a 'hold' period to maintain the AGC level during pauses in speech, and is immune to noise interference. In addition it will smoothly follow the fading signals characteristic of HF communication.

When used in a receiver comprising one SL610C and one SL612C amplifier and a suitable detector, the SL621C will maintain the output within a 4dB range for a 110dB range of receiver input signal

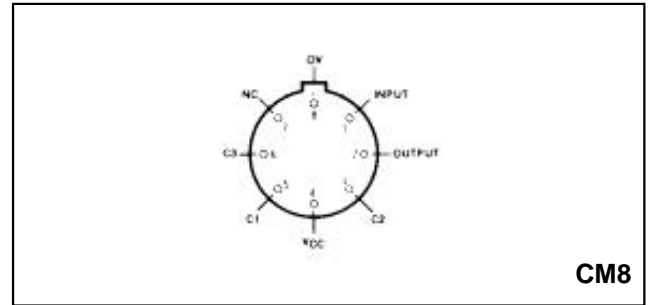

Fig.1 Pin connections (bottom view)

FEATURES

- All Time Constants Set Externally
- Easy Interfacing
- Compatible with SL610/611/612

QUICK REFERENCE DATA

- Supply voltage: 6V
- Supply current: 3mA

ORDERING INFORMATION

- SL621 C CM
- SL621 CB CM

APPLICATIONS

- SSB Receivers
- Test Equipment

ABSOLUTE MAXIMUM RATINGS

Supply voltage:	12V
Storage temperature:	-65°C to +150°C
Operating temperature range	-30°C to +85°C
Chip operating temperature	+175°C
Thermal resistance	
Chip-to-ambient	225°C/W
Chip-to-case	65°C/W

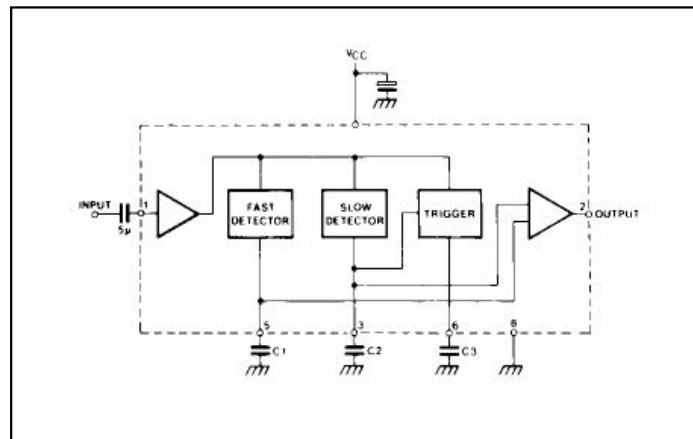

Fig.2 Block diagram

SL621

ELECTRICAL CHARACTERISTICS

These characteristics are guaranteed over the following conditions (unless otherwise stated)

Supply voltage $V_{CC} = 6V$

Ambient temperature: $22^{\circ}C \pm 2^{\circ}C$

Test frequency: 1KHz

Test circuit as Fig.2

Characteristics	Value			Units	Conditions
	Min.	Typ.	Max.		
Supply current		3.1	4.3	mA	No signal
Cut-of-frequency (-3dB)		6		KHz	
Input for 2.2V DC output	3	7	11	mVrms	
Input for 4.6V DC output	9	11	16	mVrms	
Maximum output voltage	5.1			V	
AC ripple on output		12	20	mV pk-pk	1KHz, output open circuit
Input resistance	350	500	700	Ω	
Output resistance		70	230	Ω	
'Fast' rise time t_1		20	55	ms	0 to 50% full output
'Fast' decay time t_2	150	200	330	ms	100% to 36% full output
'Slow' rise time t_3	150	200	300	ms	Time to output transition point
Hold collapse time t_4	65	100	150	ms	90% to 10% full output
Hold time t_5	0.75	1.0	1.25	s	

APPLICATION NOTES

The SL621 C consists of an input AF amplifier coupled to a DC output amplifier by means of two detectors having short and long rise and fall times respectively. The time constants of these detectors are set externally by capacitors on pins 5 (C_1) and 3 (C_2).

The detected audio signal at the input will rapidly establish an AGC level via the 'fast' detector time in t_1 (see Fig. 3). Meanwhile the long time constant detector output will rise and after t_3 will control the output because this detector is more sensitive.

Input signals greater than approximately 4mV rms will actuate a trigger circuit whose output pulses provide a discharge current for C_2 .

By this means the voltage on C_2 can decay at a maximum rate, which corresponds to a rise in receiver gain of 20dB/s. Therefore the AGC system will smoothly follow signals which are fading at this rate or slower. However should the receiver input signals fade faster than this, or disappear completely as during pauses in speech, then the input to the AGC generator will drop below the 4mV rms threshold and the trigger will cease to operate. As C_2 then has no discharge path, it will hold its charge (and hence the output AGC level) at the last attained value. The output of the short time constant detector will drop to zero in time t_2 after the disappearance of the signal.

The trigger pulses also charge C_3 . When the trigger pulses cease, C_3 discharges and after t_5 C_2 is discharged rapidly (in time t_4) and so full receiver gain is restored. The hold time, t_5 is approximately one second with $C_3 = 100\mu F$.

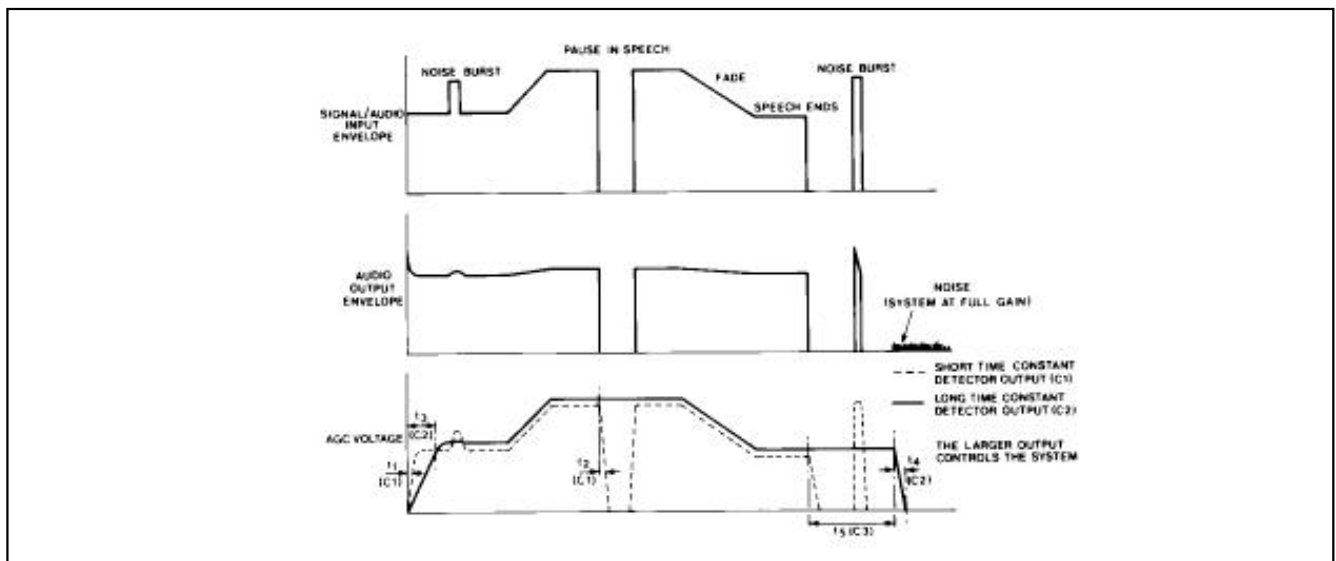

Fig.3 Dynamic response of a system controlled by SL621C AGC generator

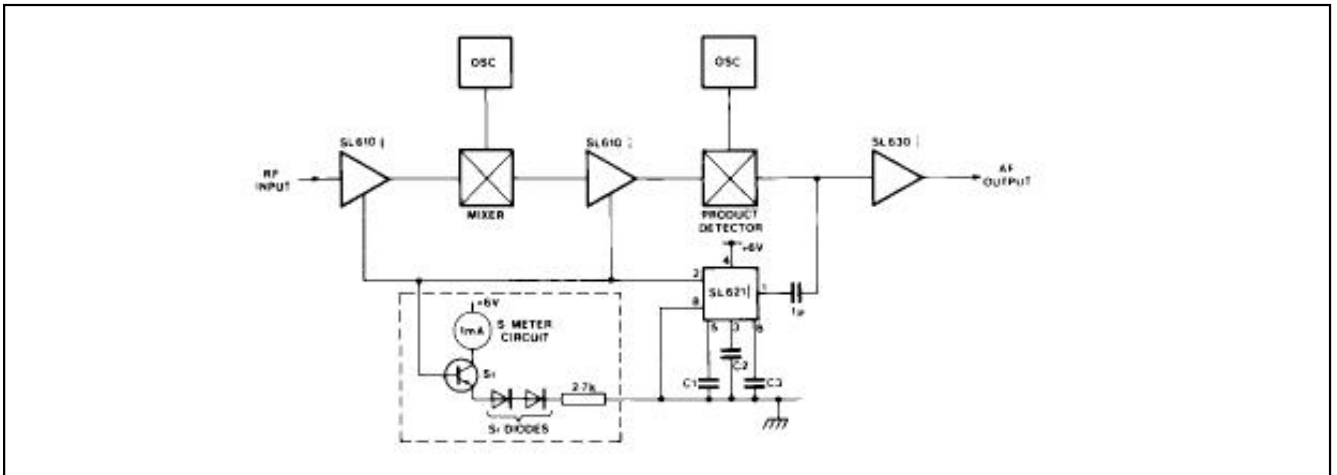

Fig.4 SL621C used to control SSB receiver

If signals reappear during t_5 , then C_3 will recharge and normal operation will continue. The C_3 recharge time is made long enough to prevent prolongation of the hold time by noise pulses.

Fig. 3 shows how a noise burst superimposed on speech will initiate rapid AGC action via the short time constant detector while the long time constant detector effectively remembers the pre-noise AGC level.

The various time constants quoted are for $C_1 = 50\text{pF}$ and $C_2 = C_3 = 100\mu\text{F}$. These time constants may be altered by varying the appropriate capacitors C_1 controls t_1, t_2 ; C_2 controls t_3, t_4 ; C_3 controls t_5 .

The supply must either have a source resistance of less than 2Ω at LF or be decoupled by at least $500\mu\text{F}$ so that it is not affected by the current surge resulting from a sudden input on pin 1.

In a receiver for both AM and SSB using an SL623C detector/carrier AGC generator, the AGC outputs of the SL621 C and SL623C may be connected together provided that no audio reaches the SL621 C input while the SL623C is controlling the system.

AGC lines may require some RF decoupling but the total capacitance on the output should not exceed 15000pF or the impulse suppression will suffer.

Under some conditions, overload of the AGC output may occur in a receiver. Possible solutions are shown in Figs 6 and 7.

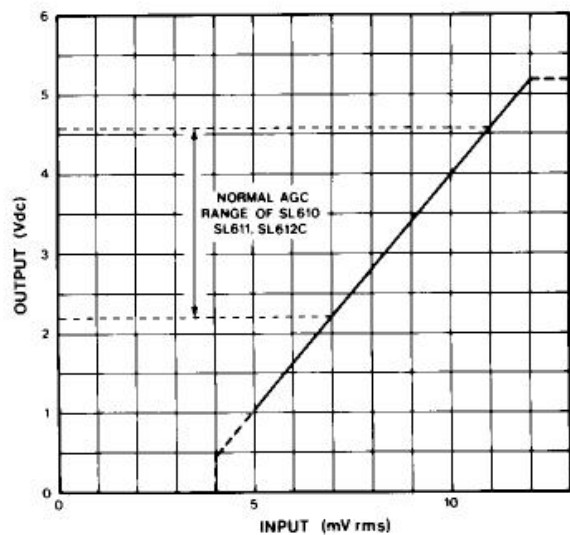

Fig.5 Transfer characteristic of SL621C (typical)

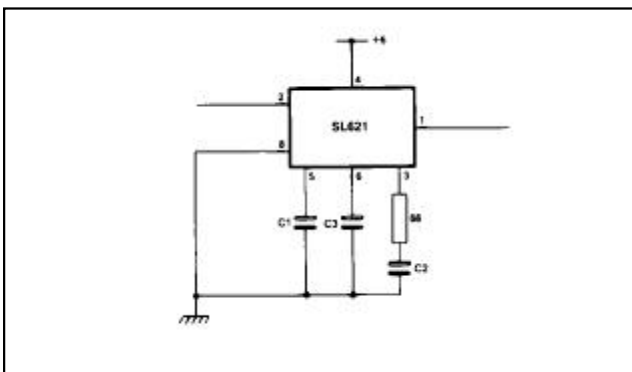

Fig.6

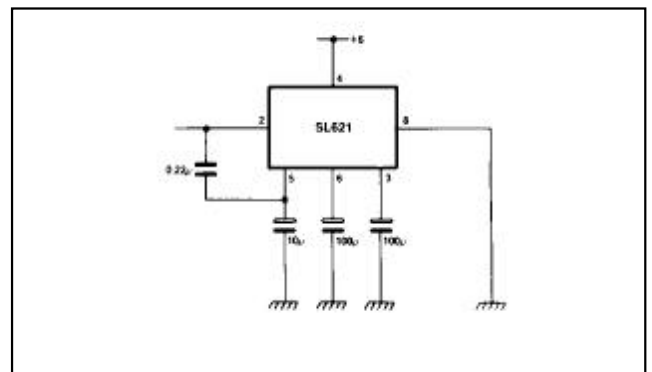

Fig.7