

5-phase Stepper Motor Pentagon Connection Driver ICs

SI-7502

SLA5011

SLA6503

■ Absolute maximum ratings

(Ta = 25°C)

Type No.	Parameter	Symbol	Ratings	Unit
SI-7502	Motor supply voltage	V _{CC}	44	V
	Auxiliary supply voltage	V _S	15	V
	Control voltage	V _b	7	V
	Reference voltage	V _{ref}	1.5	V
	Detected voltage	V _{RS}	5	V
	Power dissipation	P _D	1	W
	Ambient operating temperature	T _{OP}	0 to +65	°C
SLA5011	Drain source voltage	V _{DSS}	60	V
	Drain current	I _D	±5	A
	Avalanche energy proof quantity (Single pulse)	E _{AS}	2	mJ
	Power dissipation	P _T	35	W
	Channel temperature	T _{ch}	150	°C
	Storage temperature	T _{stg}	-40 to +150	°C
SLA6503	Collector-Base voltage	V _{CB0}	-60	V
	Controller-Emitter voltage	V _{CEO}	-60	V
	Emitter-Base voltage	V _{EBO}	-6	V
	Collector current	I _c	-3	A
	Collector current (Pulse)	I _c (pulse)	-6	A
	Base current	I _B	-1	A
	Power dissipation	P _T	35	W
	Junction temperature	T _J	150	°C
Storage temperature	T _{stg}	-40 to +150	°C	

SI-7502, SLA5011 and SLA6503

■ Electrical characteristics

Type No.	Parameter	Symbol	Limit			Unit	Condition
			min	typ	max		
SI-7502	Supply current	I_{CC}			40	mA	$V_{CC} = 42V, V_b = 5.5V$
		I_S			12.5	mA	$V_S = 12.4V$
		I_b			50	mA	$V_b = 5.5V$
	Input current	I_{IU-L}, I_{IL-L}			1.6	mA	$V_{IU} = V_{IL} = 0.4V$
	Upper drive circuit drive current	I_{OU-on}	8		11	mA	$V_b = 5V, AIU \text{ to } EIU \text{ pin open}$
		I_{OU-off}			10	μA	$V_b = 5V$
	Lower drive circuit voltage	V_{OL-on}	$V_S - 1.5$			V	$V_b = 5V, AIL-EIL \text{ pin open}$
		V_{OL-off}			1.5	V	$V_b = 5V$
Oscillation frequency	F	20		30	kHz	$V_b = 5V$	
Detected current	V_{RS}	0.8		1.05	V	$V_b = 5V, V_{ref} \text{ pin}$	
SLA5011	Gate threshold voltage	V_{TH}	2.0		4.0	V	$V_{DS} = 10V, I_D = 250\mu A$
	Current transmission conductance	$Re(y_{fs})$	2.2	3.3		S	$V_{DS} = 10V, I_D = 5A$
	DC ON-resistance	$R_{DS(ON)}$		0.17	0.22	Ω	$V_{GS} = 10V, I_D = 5A$
	Input capacity	C_{ISS}		300		pF	$V_{DS} = 25V, f = 1.0MHz,$
	Output capacity	C_{OSS}		160		pF	$V_{GS} = 0V$
	Di forward voltage between source and drain	V_{SD}		1.1	1.5	V	$I_{SD} = 5A$
Di reverse recovery time between source and drain	t_{rr}		150		ns	$I_{SD} = \pm 100mA$	
SLA6503	Collector cut-off current	I_{CBO}			-10	μA	$V_{CB} = -60V$
	Collector emitter voltage	V_{CEO}	-60			V	$I_C = -10mA$
	DC current gain	h_{FE}	2000				$V_{CE} = -4V, I_C = -3A$
	Collector emitter saturation voltage	$V_{CE(sat)}$			-1.5	V	$I_C = -3A, I_B = -6mA$

■ Block diagram

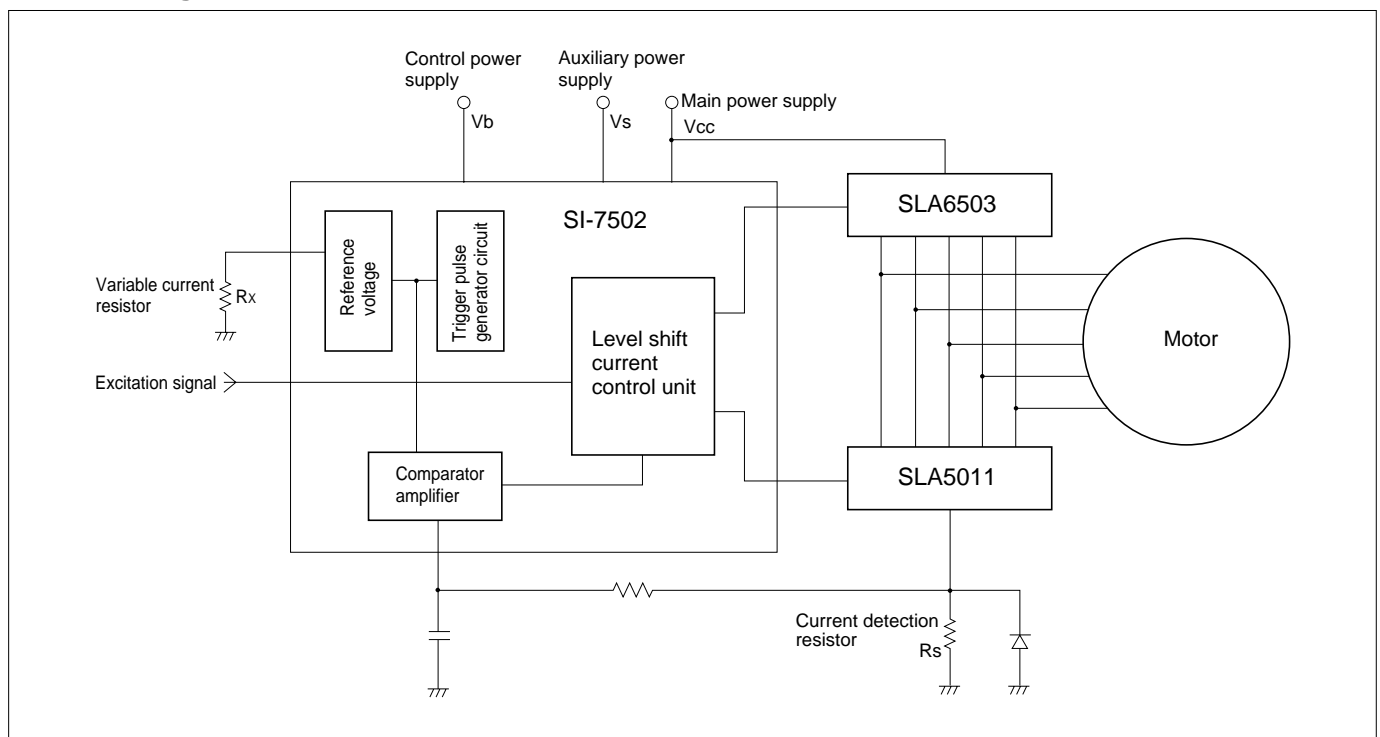

SI-7502, SLA5011 and SLA6503

Equivalent circuit diagram

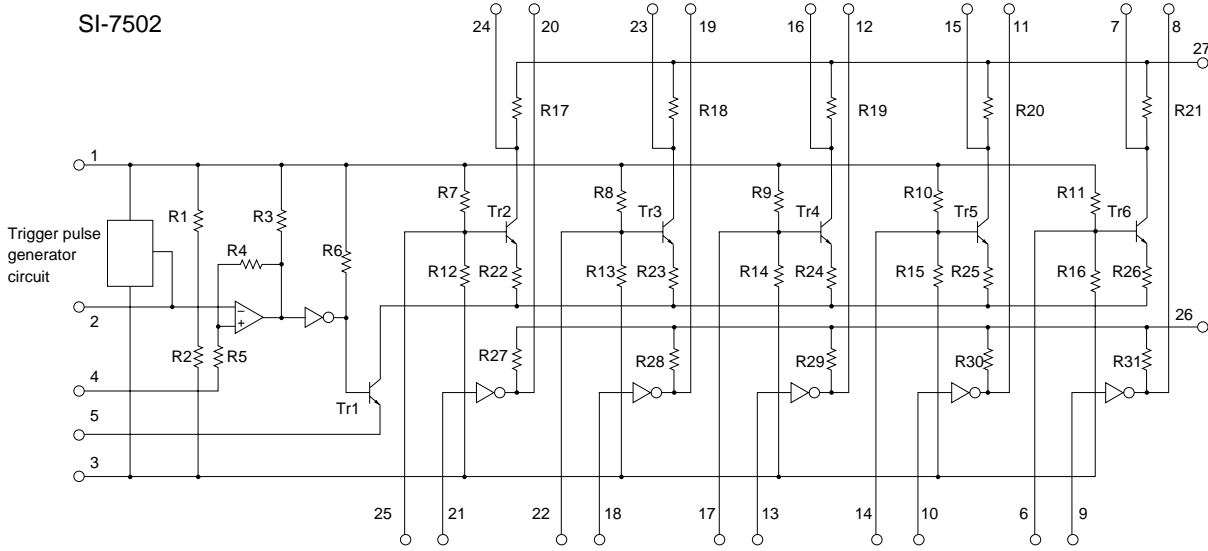

SLA6503

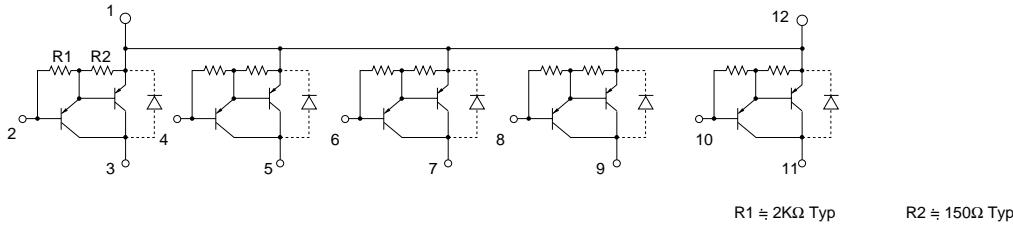

SLA5011

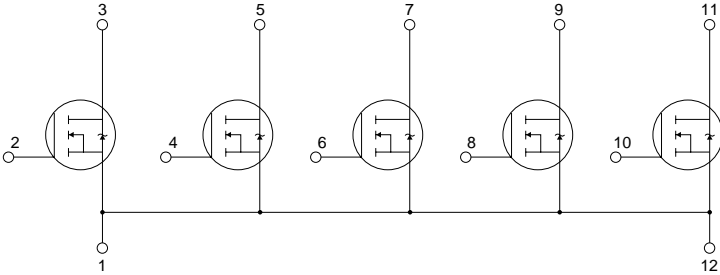

SI-7502, SLA5011 and SLA6503

External connection diagram

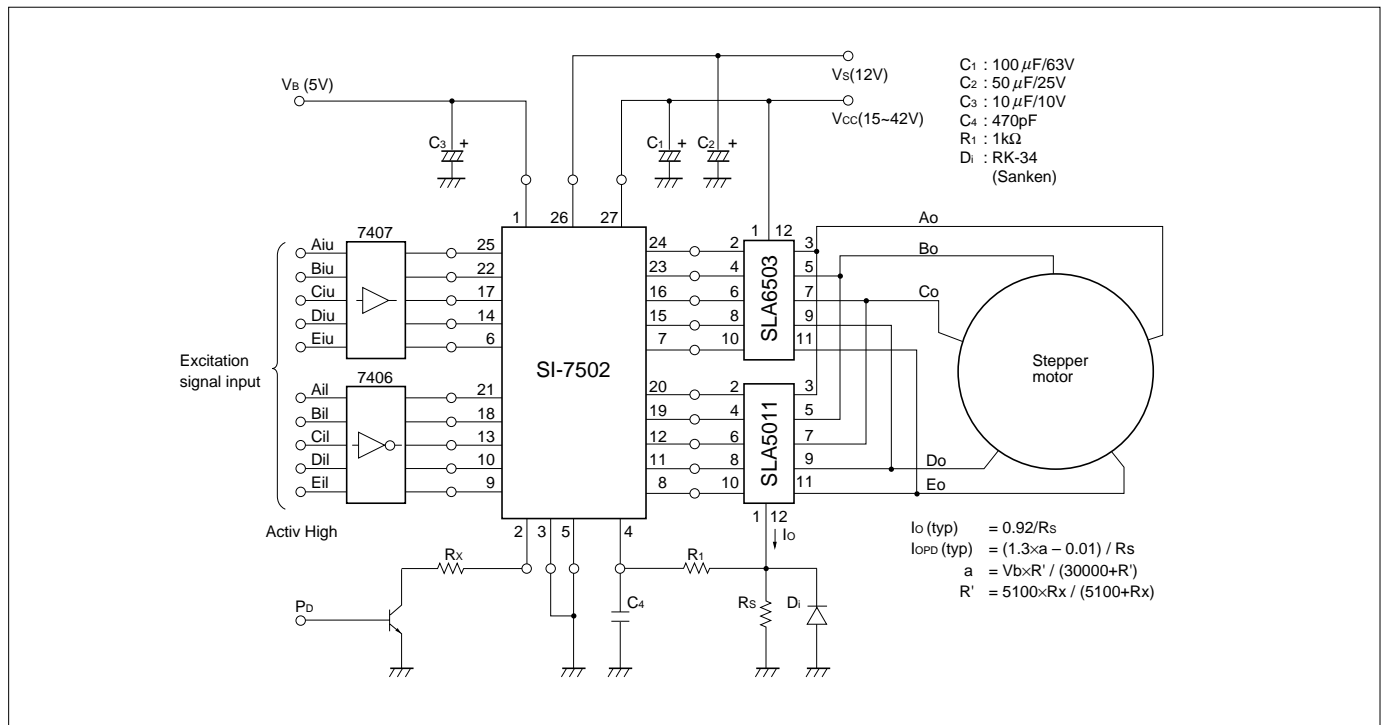

External dimensions (Unit: mm)

SI-7502

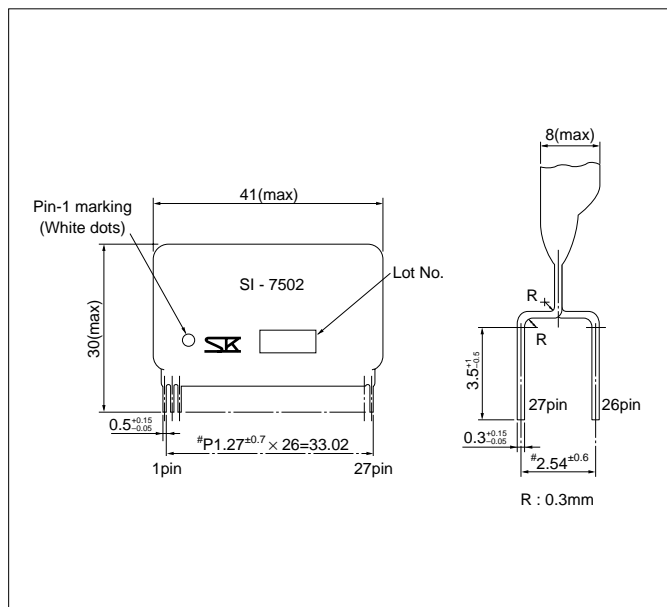

SLA6503/SLA5011

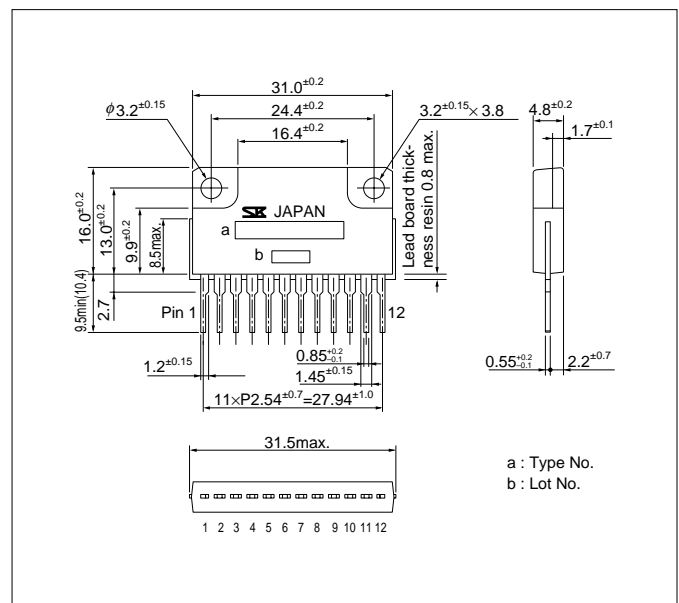

Application Note

■ Determining the output current I_o (motor coil current)

The main elements that determine the output current are Current detection resistor R_s , Supply voltage V_b , and Variable current resistor R_x .

(1) Normal mode

To operate a motor at maximum current level, set R_x to infinity (open).

From Fig. A, when the maximum output current ripple is designated as I_{OH} , its value will be,

$$I_{OH} = \frac{V_{RSH}}{R_s} \dots\dots\dots [A]$$

V_{RSH} can be computed as follows:

$$V_{RSH} = 0.19 \times V_b - 0.03 \text{ (center value)} \dots\dots\dots [B]$$

From equations [A] and [B], the output current I_{OH} can be computed as follows:

$$I_{OH} = \frac{I}{R_s} (0.19 \times V_b - 0.03)$$

The relationship between I_{OH} and R_s is shown in Fig. B.

(2) Power down mode

When an external resistor R_x is connected, V_{RSH} changes as shown in the Fig. C even when R_s is retained. Obtain the power down output current I_{OHPD} from Fig. C and equation [A].

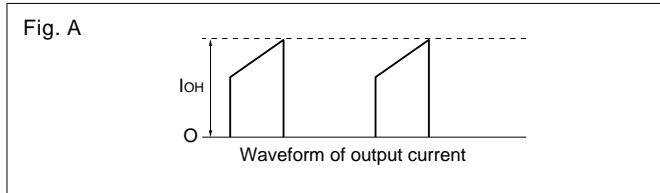

■ Relation between Output Current I_o (Control Current) and Motor Winding Current I_{OM}

The SI-7502 adopts the total current control system; therefore, the output current I_o is different from the motor winding current. In a general pentagonal driving system, the current flows as shown in Figure D. The relation between I_o and I_{OM} is as follows:

$$I_o = 4 \times I_{OM}$$

The following relation is obtained depending on driving systems:

$$I_o = 2 \times I_{OM}$$

Fig. B Output current vs. Current detection resistor

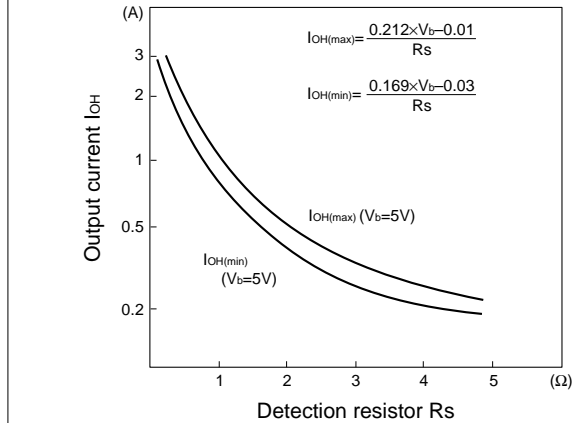

Fig. C Detection voltage vs. Variable current resistor

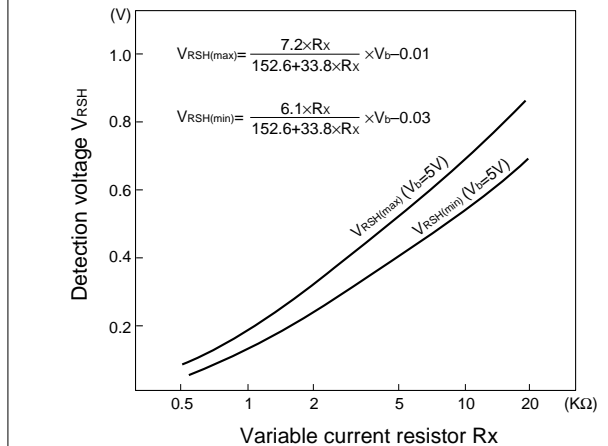
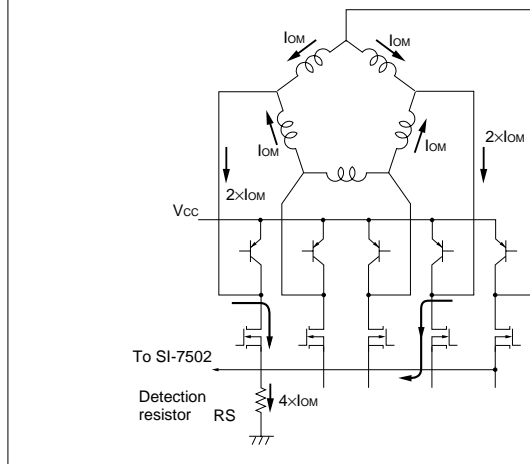

Fig. D Coil current flow at pentagonal driving



SI-7502, SLA5011 and SLA6503

■ Motor connection

The 5-phase stepping motor supports various driving systems and the motor connection varies depending on those driving systems.

In some driving systems, the use of the motor may be restricted by patents. Therefore, be sure to ask the motor manufacturer about the motor connection and driving system to be used.

■ Thermal design

The driver (SLA5011/SLA6503) dissipation varies depending on a driving system to be used even if those output currents (control current) are the same. Therefore, measure the temperature rise of the driver under the actual operation conditions and determine the size of heatsink.

Figure E shows an SLA5011/SLA6503 derating curve. This derating curve indicates $T_j = 150^\circ\text{C}$; however, before using this device, set a margin and select a heatsink so that $T_c < 100^\circ\text{C}$ (Al FIN temperature on the back of the SLA) is obtained.

Fig. E SLA5011/SLA6503 Derating curve

