Description

The SLD332F is a 1W high power laser diode designed to have a uniform emission area that is suitable for the applications for solid-state laser excitation, measurement, printing, etc.

Features

www.DataSheet4U.com

- ◆ High-power
Recommended optical power output $P_o = 1W$
- ◆ High-optical power density: $1W/100\mu m$ (Emitting line width)

Package

M-S035

Structure

- ◆ AlGaAs quantum well structure laser diode

Operating Lifetime

- ◆ MTTF 10,000h (effective value) at $P_o = 1W$, $T_c = 25^\circ C$

Sony reserves the right to change products and specifications without prior notice. This information does not convey any license by any implication or otherwise under any patents or other right. Application circuits shown, if any, are typical examples illustrating the operation of the devices. Sony cannot assume responsibility for any problems arising out of the use of these circuits.

Absolute Maximum Ratings

(Tc = 25°C)

♦ Optical power output	Pomax	1.1	W
♦ Reverse voltage	VR LD	2	V
♦ Operating temperature	Tc	-10 to +30	°C
♦ Storage temperature	Tstg	-40 to +85	°C

Warranty

Reliability assurance does not apply to this product. Because of the nature of an open heat sink product, the product shall be handled with special care to avoid any damage by handling and atmosphere including dusts and humidity. Quality shall be assured by proper atmosphere maintained by sealed packaging. Laser diodes naturally has differing lifetimes which follow a Weibull distribution.

www.DataSheet4U.com

Electrical and Optical Characteristics

(Tc = Case temperature, Tc = 25°C)

Item	Symbol	Conditions	Min.	Typ.	Max.	Unit	
Threshold current	I _{th}		—	0.4	0.5	A	
Operating current	I _{op}	P _o = 1W	—	1.2	1.5	A	
Operating voltage	V _{op}	P _o = 1W	—	1.8	3.0	V	
Wavelength	λ _p	P _o = 1W	805	—	811	nm	
Radiation angle	Perpendicular	θ _⊥	P _o = 1W	15	24	33	degree
	Parallel	θ _{//}	P _o = 1W	4	8	15	degree
Positional accuracy	Position	ΔX		—	—	±100	μm
		ΔY		—	—	±100	μm
	Angle	Δθ _⊥	P _o = 1W	—	—	±3	degree
		Δθ _{//}	P _o = 1W	—	—	±4	degree
Differential efficiency	η _D	P _o = 1W	0.65	1.1	—	W/A	

Notes On Handling

Care should be taken for the following points when using this product.

1. This product corresponds to a Class 4 product under IEC60825-1 and JIS standard C6802 "Laser Product Emission Safety Standards".

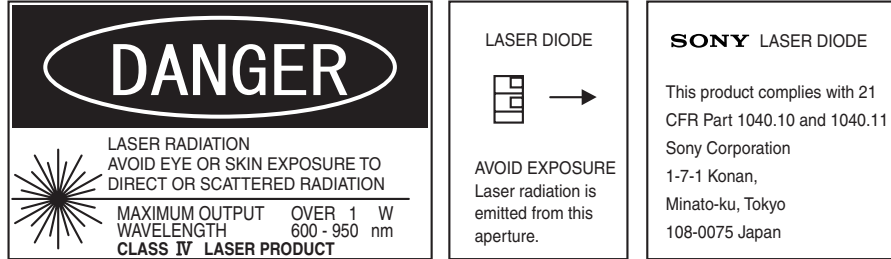

2. Eye protection against laser beams

Take care not to allow laser beams to enter your eyes under any circumstances.

For observing laser beams, ALWAYS use safety goggles that block laser beams. Usage of IR scopes, IR cameras and fluorescent plates is also recommended for monitoring laser beams safely.

3. Gallium Arsenide

This product uses gallium arsenide (GaAs). This is not a problem for normal use, but GaAs vapors may be potentially hazardous to the human body. Therefore, never crush, heat to the maximum storage temperature or higher, or place the product in your mouth.

In addition, the following disposal methods are recommended when disposing of this product.

- (1) Engaging the services of a contractor certified in the collection, transport and intermediate treatment of items containing arsenic.
- (2) Managing the product through to final disposal as specially managed industrial waste which is handled separately from general industrial waste and household waste.

4. Prevention of surge current and electrostatic discharge

Laser diodes are most sensitive to electrostatic discharge among semiconductors. When a large current is passed through the laser diode for even an extremely short time, the strong light emitted from the laser diode promotes deterioration and then destruction of the laser diode. Therefore, note that surge current should not flow to the laser diode driving circuit from switches and others. Also, if the laser diode is handled carelessly, it may be destroyed instantly because electrostatic discharge is easily applied by a human body. Therefore, be extremely careful about overcurrent and electrostatic discharge.

5. Use for special applications

This product is not designed or manufactured for use in equipment used under circumstances where failure may pose a risk to life and limb, or result in significant material damage, etc.

Consult your Sony sales representative when investigating use for medical, vehicle, nuclear power control or other special applications. Also, use the power supply that was designed not to exceed the optical power output specified at the absolute maximum ratings.

6. Environment-related Substances to be Controlled

No substances classified at Level 1 (immediate ban) of Sony Technical Standard, SS-00259, "Management regulations for the Environment-related Substances to be Controlled". The excerpt from SS-00259 is introduced on following URL.

<http://www.sony.net/SonyInfo/procurementinfo/ss00259/>

Package Outline

(Unit: mm)

M-S035

www.DataSheet4U.com

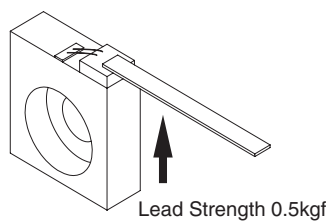
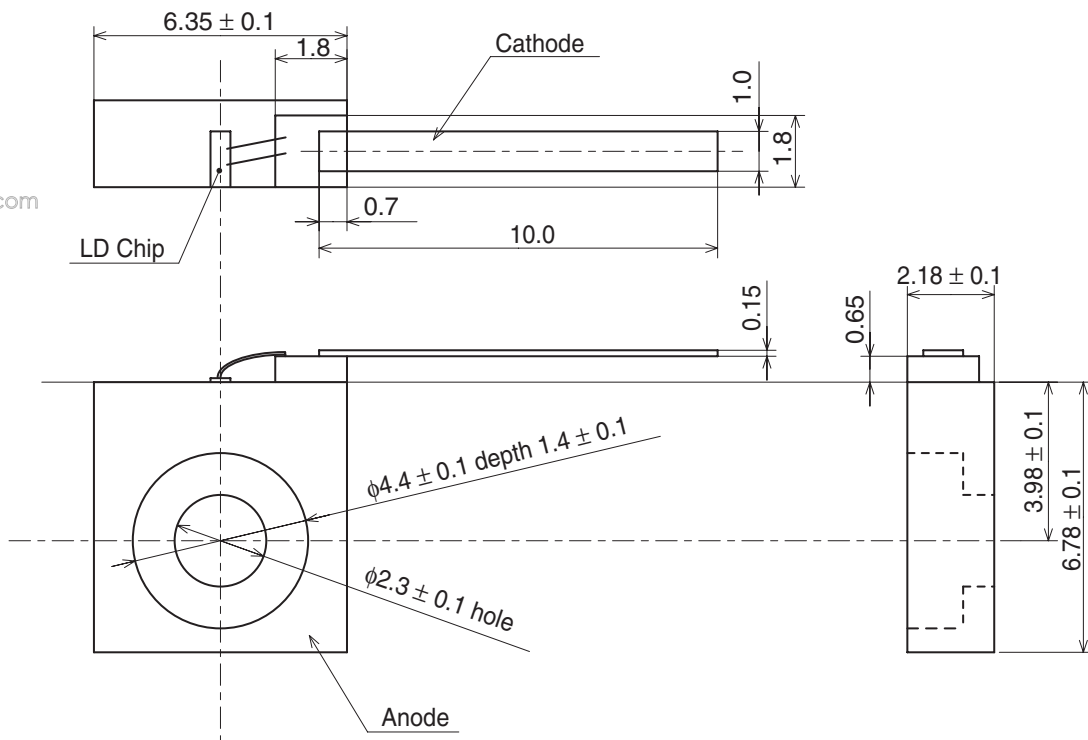

SONY CODE	M-S035
EIAJ CODE	_____
JEDEC CODE	_____

PACKAGE MASS	1g
--------------	----