



SLU5N50S / SLD5N50S

650V N-Channel MOSFET

General Description

This Power MOSFET is produced using Maple semi's advanced planar stripe DMOS technology. This advanced technology has been especially tailored to minimize on-state resistance, provide superior switching performance, and withstand high energy pulse in the avalanche and commutation mode. These devices are well suited for high efficiency switched mode power supplies, active power factor correction based on half bridge topology.

Features

- 5.0A, 500V, $R_{DS(on)} = 1.35\Omega @ V_{GS} = 10V$
- Low gate charge (typical 26nC)
- High ruggedness
- Fast switching
- 100% avalanche tested
- Improved dv/dt capability

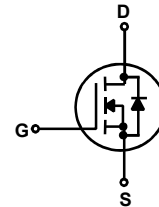
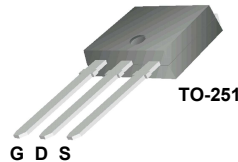
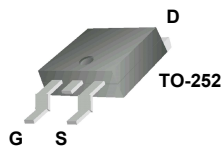

Absolute Maximum Ratings $T_C = 25^\circ C$ unless otherwise noted

Symbol	Parameter	SLU5N50S	SLD5N50S	Units
V_{DSS}	Drain-Source Voltage	500		V
I_D	Drain Current - Continuous ($T_C = 25^\circ C$)	5.0		A
	Drain Current - Continuous ($T_C = 100^\circ C$)	3.0		A
I_{DM}	Drain Current - Pulsed (Note 1)	20		A
V_{GSS}	Gate-Source Voltage	± 30		V
EAS	Single Pulsed Avalanche Energy (Note 2)	280		mJ
I_{AR}	Avalanche Current (Note 1)	5.0		A
E_{AR}	Repetitive Avalanche Energy (Note 1)	--		mJ
dv/dt	Peak Diode Recovery dv/dt (Note 3)	5.5		V/ns
P_D	Power Dissipation ($T_C = 25^\circ C$)	50		W
T_J, T_{STG}	Operating and Storage Temperature Range	-55 to +150		$^\circ C$
T_L	Maximum lead temperature for soldering purposes, 1/8" from case for 5 seconds	300		$^\circ C$

Thermal Characteristics

Symbol	Parameter	Max		Units
		SLU5N50S	SLD5N50S	
$R_{\theta JC}$	Thermal Resistance, Junction-to-Case	2.50	2.50	$^\circ C/W$
$R_{\theta JS}$	Thermal Resistance, Case-to-Sink Typ.	62.5	62.5	$^\circ C/W$
$R_{\theta JA}$	Thermal Resistance, Junction-to-Ambient	110	110	$^\circ C/W$

Electrical Characteristics

$T_C = 25^\circ \text{C}$ unless otherwise noted

Symbol	Parameter	Test Conditions	Min	Typ	Max	Units
Off Characteristics						
BV_{DSS}	Drain-Source Breakdown Voltage	$V_{GS} = 0 \text{ V}, I_D = 250 \mu\text{A}$	500	--	--	V
$\Delta BV_{DSS} / \Delta T_J$	Breakdown Voltage Temperature Coefficient	$I_D = 250 \mu\text{A}$, Referenced to 25°C	--	0.6	--	V/ $^\circ \text{C}$
I_{DSS}	Zero Gate Voltage Drain Current	$V_{DS} = 500 \text{ V}, V_{GS} = 0 \text{ V}$	--	--	25	μA
		$V_{DS} = 400 \text{ V}, T_C = 125^\circ \text{C}$	--	--	250	μA
I_{GSSF}	Gate-Body Leakage Current, Forward	$V_{GS} = 30 \text{ V}, V_{DS} = 0 \text{ V}$	--	--	100	nA
I_{GSSR}	Gate-Body Leakage Current, Reverse	$V_{GS} = -30 \text{ V}, V_{DS} = 0 \text{ V}$	--	--	-100	nA
On Characteristics						
$V_{GS(th)}$	Gate Threshold Voltage	$V_{DS} = V_{GS}, I_D = 250 \mu\text{A}$	2.0	--	4.0	V
$R_{DS(on)}$	Static Drain-Source On-Resistance	$V_{GS} = 10 \text{ V}, I_D = 2.0 \text{ A}$	--	1.35	1.5	Ω
g_{FS}	Forward Transconductance	$V_{DS} = 40 \text{ V}, I_D = 2.0 \text{ A}$ (Note 4)	2.4	--	--	S
Dynamic Characteristics						
C_{iss}	Input Capacitance	$V_{DS} = 25 \text{ V}, V_{GS} = 0 \text{ V}, f = 1.0 \text{ MHz}$	--	560	--	pF
C_{oss}	Output Capacitance		--	45	--	pF
C_{riss}	Reverse Transfer Capacitance		--	17	--	pF
Switching Characteristics						
$t_{d(on)}$	Turn-On Delay Time	$V_{DD} = 250 \text{ V}, I_D = 5.0 \text{ A}, R_G = 25 \Omega$ (Note 4, 5)	--	--	--	ns
t_r	Turn-On Rise Time		--	--	--	ns
$t_{d(off)}$	Turn-Off Delay Time		--	20	--	ns
t_f	Turn-Off Fall Time		--	--	--	ns
Q_g	Total Gate Charge	$V_{DS} = 480 \text{ V}, I_D = 4.0 \text{ A}, V_{GS} = 10 \text{ V}$ (Note 4, 5)	--	13.3	--	nC
Q_{gs}	Gate-Source Charge		--	4.0	--	nC
Q_{gd}	Gate-Drain Charge		--	15	--	nC
Drain-Source Diode Characteristics and Maximum Ratings						
I_S	Maximum Continuous Drain-Source Diode Forward Current		--	--	5.0	A
I_{SM}	Maximum Pulsed Drain-Source Diode Forward Current		--	--	20	A
V_{SD}	Drain-Source Diode Forward Voltage	$V_{GS} = 0 \text{ V}, I_S = 4.0 \text{ A}$	--	--	1.6	V
t_{rr}	Reverse Recovery Time	$V_{GS} = 0 \text{ V}, I_S = 4.0 \text{ A}$	--	220	--	ns
Q_{rr}	Reverse Recovery Charge	$di_F / dt = 100 \text{ A/us}$ (Note 4)	--	1.0	--	μC

Notes:

1. Repetitive Rating : Pulse width limited by maximum junction temperature
2. $I_{AS} = 5.0 \text{ A}, L = 24 \text{ mH}, V_{DD} = 50 \text{ V}, R_G = 25 \Omega$, Starting $T_J = 25^\circ \text{C}$
3. $I_{SD} \leq 5.0 \text{ A}, di/dt \leq 200 \text{ A/us}, V_{DD} \leq BV_{DSS}$, Starting $T_J = 25^\circ \text{C}$
4. Pulse Test : Pulse width $\leq 300 \mu\text{s}$, Duty cycle $\leq 2\%$
5. Essentially independent of operating temperature

Typical Characteristics

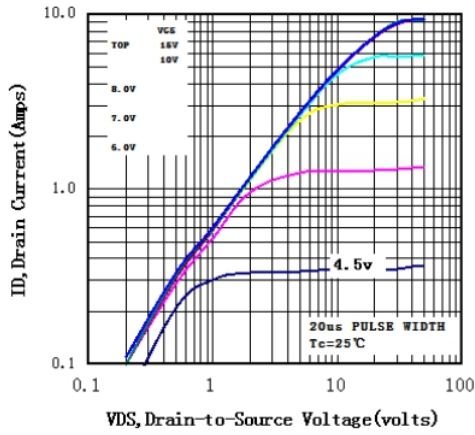

Figure 1. Typical Output Characteristics
Tc=25°C

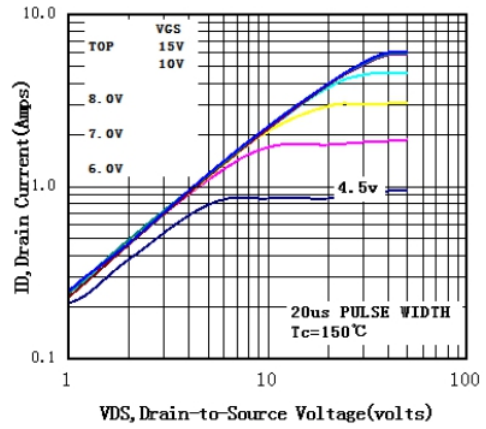

Figure 2. Typical Output Characteristics
Tc=150°C

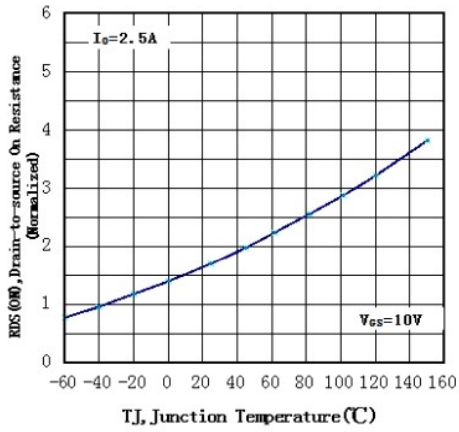

Figure 3. Normalized Resistance VS
Temperature

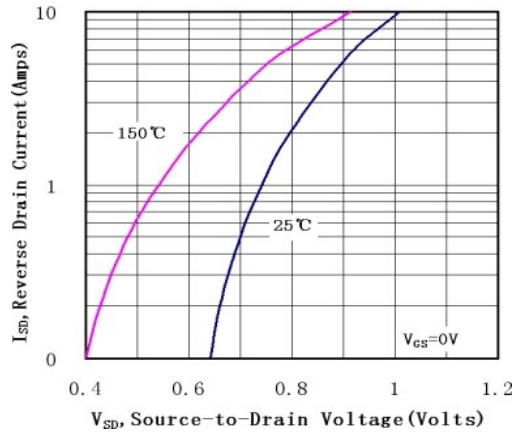

Figure 4. Typical Source-Drain Diode
Forward Voltage

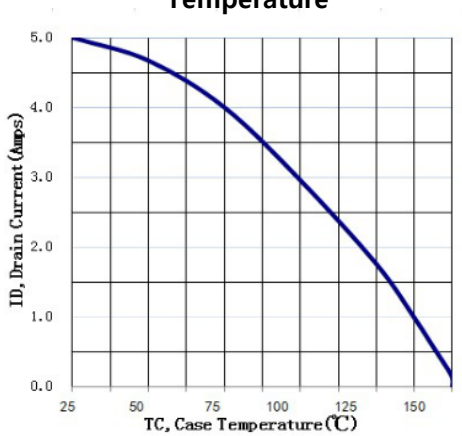

Figure 5. Maximum Current VS
Case Temperature

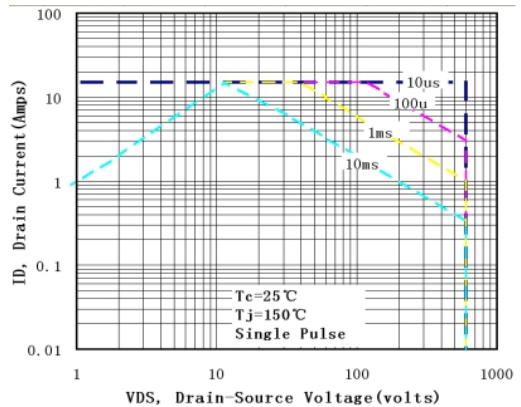
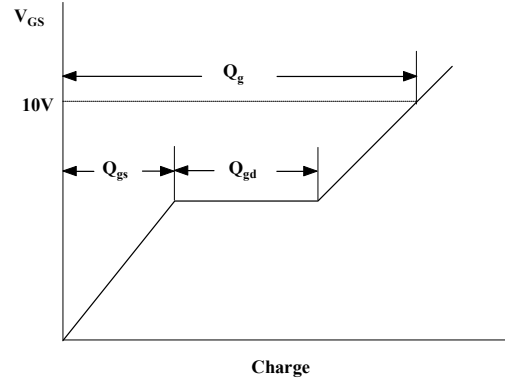
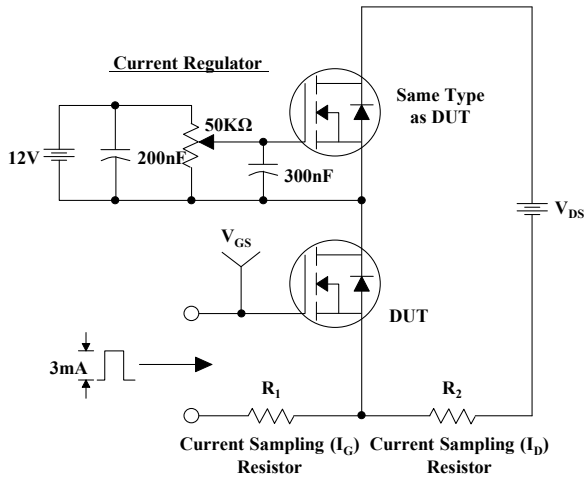
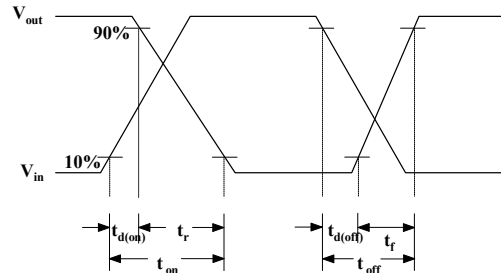
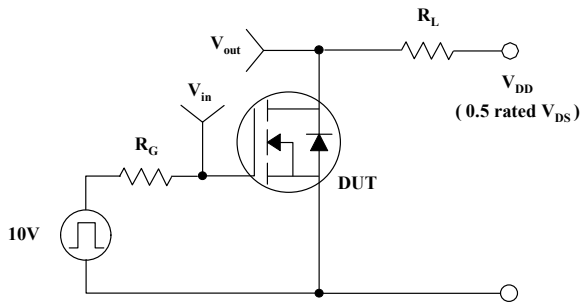

Figure 6. Maximum Safe Operating Area

Gate Charge Test Circuit & Waveform



Resistive Switching Test Circuit & Waveforms



Unclamped Inductive Switching Test Circuit & Waveforms

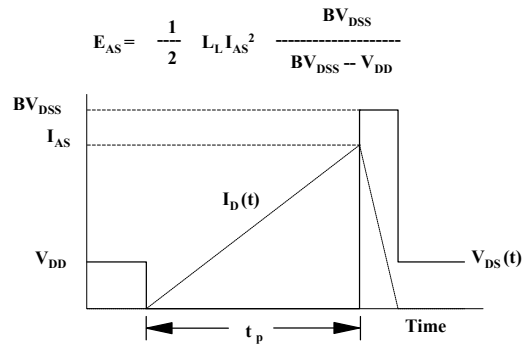
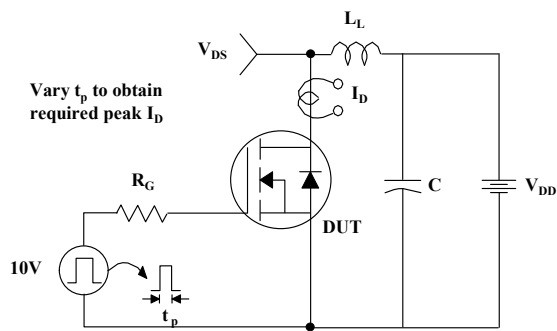

Peak Diode Recovery dv/dt Test Circuit & Waveforms

