



Clock Divider and Chip Select Extender

General Description

Silego SLG7NT4779 is a low power and small form device. The SoC is housed in a 1.6 x 1.6 mm STQFN package which is optimal for using with small devices.

Features

- Low Power Consumption
- Pb-Free / RoHS Compliant
- Halogen-Free
- STQFN-12 Package

Output Summary

- 3 Outputs — Push Pull 1X
- 1 Output — 3-State 1X

Pin Configuration

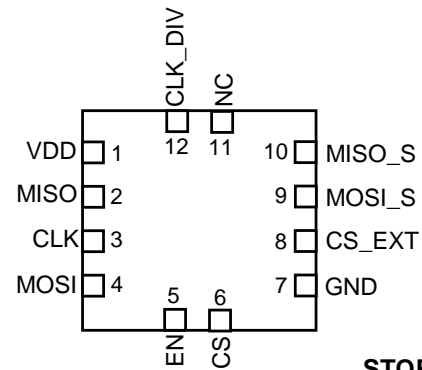

**STQFN-12
TOP VIEW**



Clock Divider and Chip Select Extender

Pin Configuration

Pin #	Pin Name	Type	Pin Description
1	VDD	PWR	Supply Voltage
2	MISO	Digital Input	Digital Input without Schmitt trigger
3	CLK	Digital Input	Digital Input without Schmitt trigger
4	MOSI	Digital Input	Digital Input without Schmitt trigger
5	EN	Digital Input	Digital Input without Schmitt trigger
6	CS	Digital Input	Digital Input without Schmitt trigger
7	GND	GND	Ground
8	CS_EXT	Digital Output	Push Pull 1X
9	MOSI_S	Digital Output	Push Pull 1X
10	MISO_S	Digital Output	3-State Output 1X
11	NC	--	Keep Floating or Connect to GND
12	CLK_DIV	Digital Output	Push Pull 1X

Ordering Information

Part Number	Package Type
SLG7NT4779V	V=STQFN-12
SLG7NT4779VTR	STQFN-12 – Tape and Reel (3k units)



Clock Divider and Chip Select Extender

Absolute Maximum Conditions

Parameter	Min.	Max.	Unit
V _{HIGH} to GND	-0.3	7	V
Voltage at input pins	-0.3	7	V
Current at input pin	-1.0	1.0	mA
Storage temperature range	-65	125	°C
Junction temperature	--	150	°C
ESD Protection (Human Body Model)	2000	--	V
ESD Protection (Charged Device Model)	1000	--	V
Moisture Sensitivity Level	1		

Electrical Characteristics

(@ 25°C, unless otherwise stated)

Symbol	Parameter	Condition/Note	Min.	Typ.	Max.	Unit
V _{DD}	Supply Voltage		3	3.3	3.6	V
T _A	Operating Temperature		-40	25	85	°C
I _Q	Quiescent Current	Static inputs and outputs	--	1	--	µA
V _O	Maximal Voltage Applied to any PIN in High-Impedance State		--	--	VDD	V
I _O	Maximal Average or DC Current (note 1)	Per Each Chip Side	--	--	90	mA
V _{IH}	HIGH-Level Input Voltage	Logic Input, at VDD=3.3V	1.78	--	VDD	V
V _{IL}	LOW-Level Input Voltage	Logic Input, at VDD=3.3V	--	--	1.21	V
I _{IH}	HIGH-Level Input Current	Logic Input PINs; V _{IN} = VDD	-1.0	--	1.0	µA
I _{IL}	LOW-Level Input Current	Logic Input PINs; V _{IN} = 0V	-1.0	--	1.0	µA
V _{OH}	HIGH-Level Output Voltage (note 1)	Push Pull & PMOS OD, I _{OH} = 3mA, 1X Driver, at VDD=3.3 V	2.71	3.09	--	V
V _{OL}	LOW-Level Output Voltage (note 1)	Push Pull, I _{OL} = 3mA, 1X Driver, at VDD=3.3 V	--	0.18	0.28	V
I _{OH}	HIGH-Level Output Current (note 1)	Push Pull & PMOS OD, V _{OH} = 2.4 V, 1X Driver, at VDD=3.3 V	5.83	10.158	--	mA
I _{OL}	LOW-Level Output Current (note 1)	Push Pull, V _{OL} = 0.4V, 1X Driver, at VDD=3.3 V	4.06	6.44	--	mA
T _{PD_CLK}	CLK to CLK_DIV Propagation Delay Time		33	--	63	ns
T _{PD_CS}	CS to CS_N Propagation Delay Time		34	--	62	ns
T _{PD_MOSI}	MOSI to MOSI_S Propagation Delay Time		29	--	57	ns
T _{PD_MISO}	MISO to MISO_S Propagation Delay Time		28	--	58	ns
T _{SU}	Start up Time	From VDD rising past 1.35V	--	0.31	--	ms

1. Guaranteed by Design.



Clock Divider and Chip Select Extender

Package Top Marking

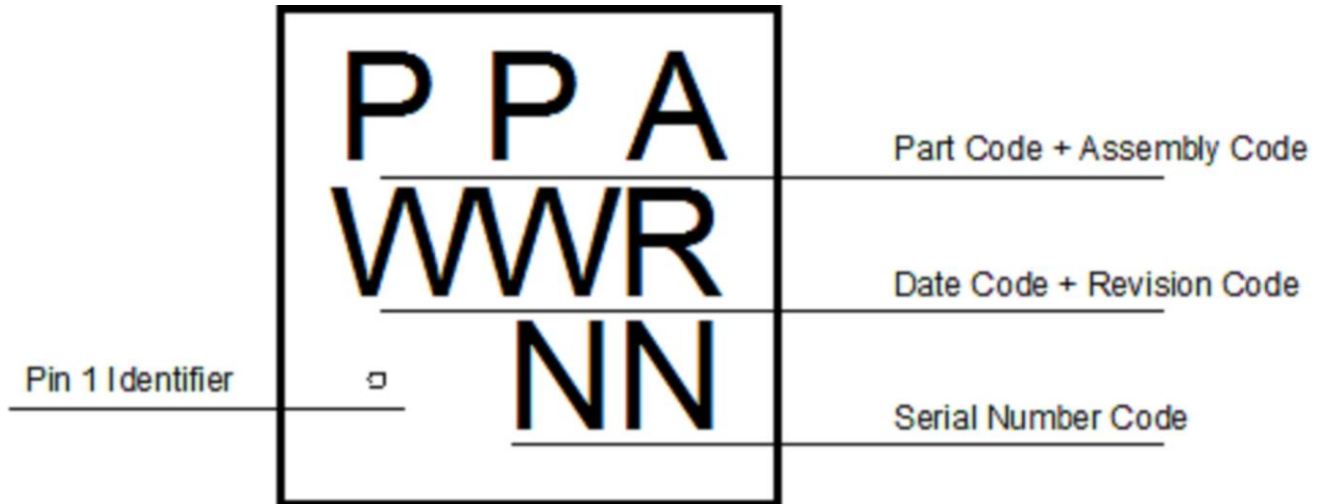

Datasheet Revision	Programming Code Number	Locked Status	Part Code	Revision	Date
0.15	004	U	UW	A	09/28/2015

The IC security bit is locked/set for code security for production unless otherwise specified. Revision number is not changed for bit locking.



Clock Divider and Chip Select Extender

Package Drawing and Dimensions

12 Lead STQFN Package
JEDEC MO-220

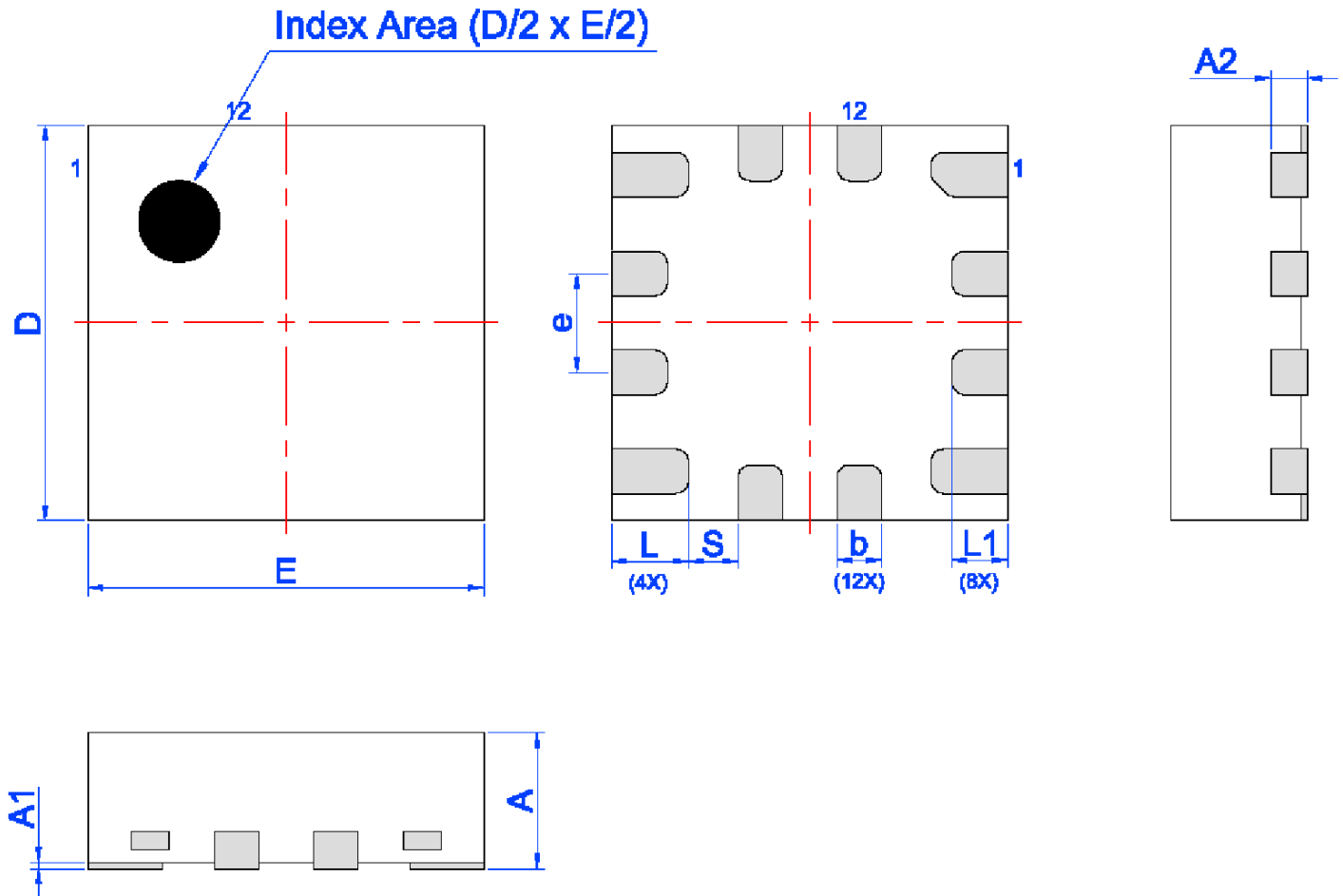

Unit: mm

Symbol	Min	Nom.	Max	Symbol	Min	Nom.	Max
A	0.50	0.55	0.60	D	1.55	1.60	1.65
A1	0.005	-	0.060	E	1.55	1.60	1.65
A2	0.10	0.15	0.20	L	0.26	0.31	0.36
b	0.13	0.18	0.23	L1	0.175	0.225	0.275
e	0.40 BSC			S	0.2 REF		



Clock Divider and Chip Select Extender

Tape and Reel Specification

Package Type	# of Pins	Nominal Package Size (mm)	Max Units		Reel & Hub Size (mm)	Trailer A		Leader B		Pocket (mm)	
			per reel	per box		Pockets	Length (mm)	Pockets	Length (mm)	Width	Pitch
STQFN 12L FC 0.4P Green	12	1.6x1.6x0.55	3000	3000	178/60	100	400	100	400	8	4

Carrier Tape Drawing and Dimensions

Package Type	Pocket BTM Length (mm)	Pocket BTM Width (mm)	Pocket Depth (mm)	Index Hole Pitch (mm)	Pocket Pitch (mm)	Index Hole Diameter (mm)	Index Hole to Tape Edge (mm)	Index Hole to Pocket Center (mm)	Tape Width (mm)
	A0	B0	K0	P0	P1	D0	E	F	W
STQFN 12L FC 0.4P Green	1.9	1.9	0.8	4	4	1.5	1.75	3.5	8

Refer to EIA-481 Specifications

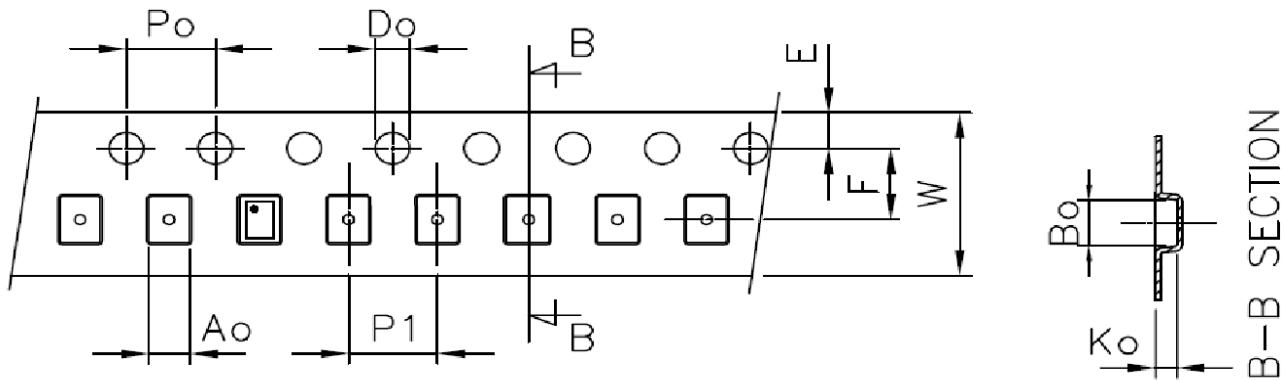

Recommended Reflow Soldering Profile

Please see IPC/JEDEC J-STD-020: latest revision for reflow profile based on package volume of 1.408 mm³ (nominal). More information can be found at www.jedec.org.



Clock Divider and Chip Select Extender

Silego Website & Support

Silego Technology Website

Silego Technology provides online support via our website at <http://www.silego.com/>. This website is used as a means to make files and information easily available to customers.

For more information regarding Silego Green products, please visit:

<http://greenpak.silego.com/>
<http://greenpak2.silego.com/>
<http://greenpak3.silego.com/>
<http://greenfet.silego.com/>
<http://greenfet2.silego.com/>
<http://greenclock.silego.com/>

Products are also available for purchase directly from Silego at the Silego Online Store at <http://www.silego.com/>

Silego Technical Support

Datasheets and errata, application notes and example designs, user guides, and hardware support documents and the latest software releases are available at the Silego website or can be requested directly at info@silego.com.

For specific GreenPAK design or applications questions and support please send e-mail requests to GreenPAK@silego.com

Users of Silego products can receive assistance through several channels:

Online Training

Silego Technology has live training assistance and sales support available at <http://www.silego.com/>. Please contact us to schedule a 1 on 1 training session with one of our application engineers.

Contact Your Local Sales Representative

Customers can contact their local sales representative or field application engineer (FAE) for support. Local sales offices are also available to help customers. More information regarding your local representative is available at the Silego website or send a request to info@silego.com

Contact Silego Directly

Silego can be contacted directly via e-mail at info@silego.com or user submission form, located at the following URL: <http://support.silego.com/>

Other Information

The latest Silego Technology press releases, listing of seminars and events, listings of worldwide Silego Technology offices and representatives are all available at <http://www.silego.com/>

THIS PRODUCT HAS BEEN DESIGNED AND QUALIFIED FOR THE CONSUMER MARKET. APPLICATIONS OR USES AS CRITICAL COMPONENTS IN LIFE

SUPPORT DEVICES OR SYSTEMS ARE NOT AUTHORIZED. SILEGO TECHNOLOGY DOES NOT ASSUME ANY LIABILITY ARISING OUT OF SUCH APPLICATIONS OR USES OF ITS PRODUCTS. SILEGO TECHNOLOGY RESERVES THE RIGHT TO IMPROVE PRODUCT DESIGN, FUNCTIONS AND RELIABILITY WITHOUT NOTICE