

General Description

This Power MOSFET is produced using Maple semi's Advanced Super-Junction technology.

This advanced technology has been especially tailored to minimize conduction loss, provide superior switching performance, and withstand high energy pulse in the avalanche and commutation mode.

These devices are well suited for AC/DC power conversion

Features

- 76A, 600V, RDS(on) typ.= 36mΩ@VGS =10 V
- Low gate charge (typical 142nC)
- High ruggedness
- Fast switching
- 100% avalanche tested
- Improved dv/dt capability

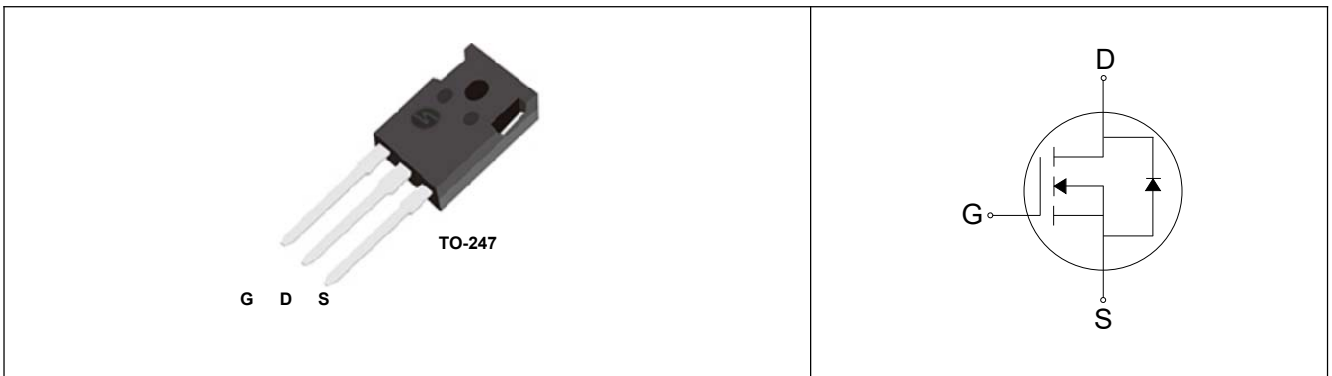

Absolute Maximum Ratings

TC = 25°C unless otherwise noted

Symbol	Parameter	SLH60R042SS	Units
VDSS	Drain-Source Voltage	600	V
ID	Drain Current - Continuous (TC = 25°C)	76	A
	- Continuous (TC = 100°C)	45*	A
IDM	Drain Current - Pulsed (Note 1)	226	A
VGSS	Gate-Source Voltage	±20	V
EAS	Single Pulsed Avalanche Energy (Note 2)	2890	mJ
dv/dt	Peak Diode Recovery dv/dt (Note 3)	45	V/ns
PD	Power Dissipation (TC = 25°C)	355	W
	- Derate above 25°C	2.86	W/°C
TJ, TSTG	Operating and Storage Temperature Range	-55 to +150	°C
TL	Maximum lead temperature for soldering purposes,	300	°C
	1/8" from case for 5 seconds		

*Drain current limited by maximum junction temperature.

Thermal Characteristics

Symbol	Parameter	Value	Units
RθJC	Thermal Resistance, Junction-to-Case	0.35	°C/W
RθJS	Thermal Resistance, Case-to-Sink Typ.	0.5	°C/W
RθJA	Thermal Resistance, Junction-to-Ambient	60	°C/W

Electrical Characteristics (TC = 25 °C unless otherwise noted)

Symbol	Parameter	Test Conditions	Min	Typ	Max	Units
Off Characteristics						
BVDSS	Drain-Source Breakdown Voltage	VGS = 0V, ID = 250uA, TJ=25°C	600	-	-	V
		VGS = 0V, ID = 250uA, TJ=150°C	-	650	-	V
Δ BVDSS Δ TJ	Breakdown Voltage Temperature coefficient	ID = 250uA, referenced to 25°C	-	0.6	-	V/°C
IDSS	Drain-Source Leakage Current	VDS =600V, VGS = 0V	-	-	1	uA
		VDS =480V, TC = 125 °C	-	10	-	uA
IGSS	Gate-Source Leakage, Forward	VGS = 20V, VDS = 0V	-	-	100	nA
	Gate-source Leakage, Reverse	VGS = -20V, VDS = 0V	-	-	-100	nA
On Characteristics						
VGS(th)	Gate Threshold Voltage	VDS = VGS, ID = 250uA	2.0	3.0	4.0	V
RDS(ON)	Static Drain-Source On-state Resistance	VGS =10 V, ID = 28A	-	36	42	mΩ
Dynamic Characteristics						
Ciss	Input Capacitance	VGS =0 V, VDS =25V, f = 1MHz	-	6018	-	pF
Coss	Output Capacitance		-	245	-	
Crss	Reverse Transfer Capacitance		-	33	-	
Dynamic Characteristics						
td(on)	Turn-on Delay Time	VDD =300V, ID =40A, RG =25Ω	-	48	-	nS
tr	Rise Time		-	114	-	
td(off)	Turn-off Delay Time		-	179	-	
tf	Fall Time		-	113	-	
Qg	Total Gate Charge	VDS =480V, VGS =40V, ID =20A	-	142	-	nC
Qgs	Gate-Source Charge		-	39	-	
Qgd	Gate-Drain Charge(Miller Charge)		-	59	-	

Source-Drain Diode Ratings and Characteristics

Symbol	Parameter	Test Conditions	Min.	Typ.	Max.	Unit.
IS	Maximum Continuous Drain-Source Diode Forward Current		-	-	76	A
ISM	Maximum Pulsed Drain-Source Diode Forward Current		-	-	226	
VSD	Diode Forward Voltage	IS =40A, VGS =0V	-	-	1.5	V
trr	Reverse Recovery Time	IS =40A, VGS=0V, dIF/dt=100A/us	-	625	-	nS
Qrr	Reverse Recovery Charge		-	2.5	-	uC

NOTES

1. Repeativity rating : pulse width limited by junction temperature
2. L =40mH, IAS =12A, VDD = 50V, RG = 25Ω, Starting TJ = 25°C
3. ISD ≤ ID, di/dt ≤ 200A/us, VDD ≤ BVDSS, Starting TJ = 25°C
4. Pulse Test : Pulse Width ≤ 300us, Duty Cycle ≤ 2%
5. Essentially independent of operating temperature.

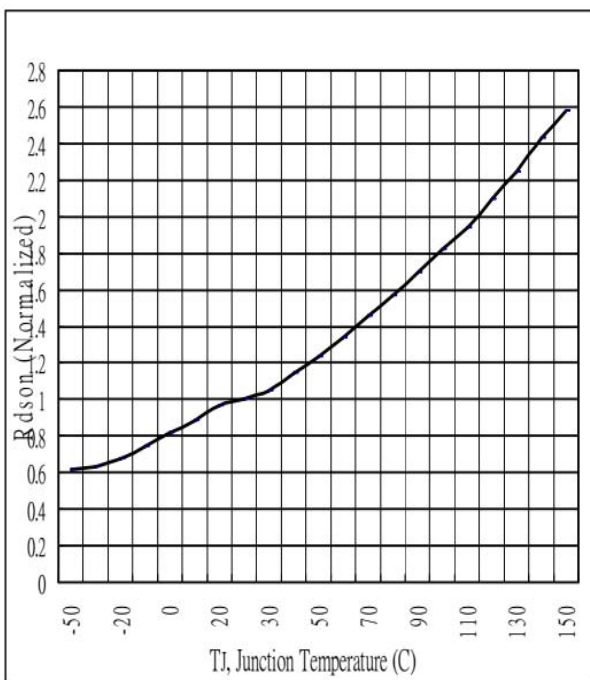

Fig 1. On-Resistance Variation with vs. Temperature

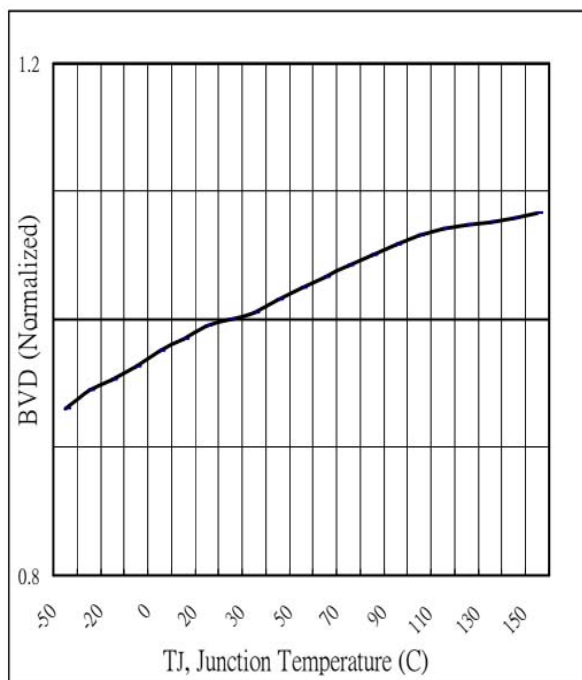

Fig.2 Breakdown Voltage Variation vs. Temperature

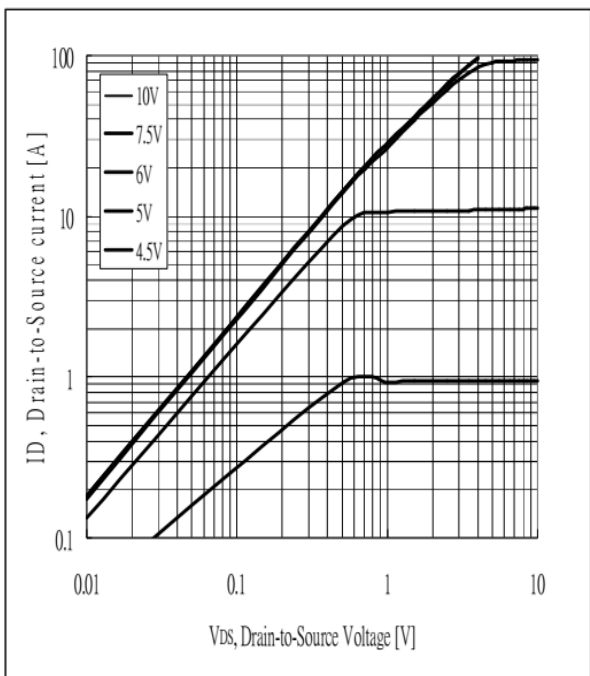

Fig 3. Typical Output Characteristics

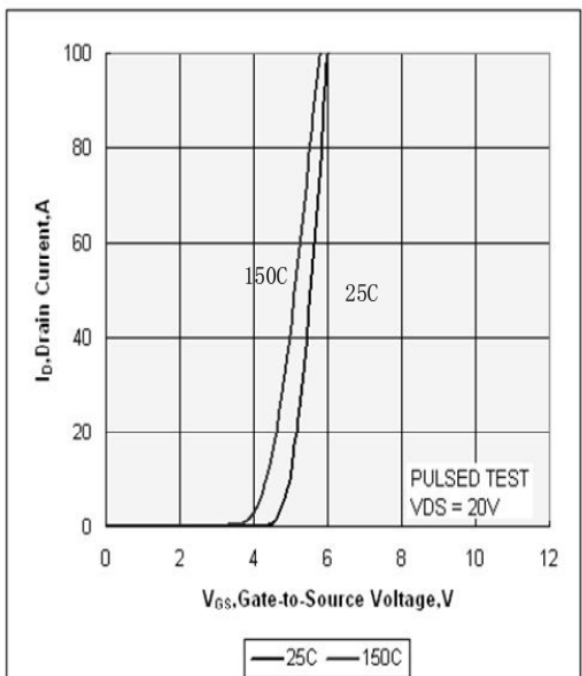

Fig 4. Typical Transfer Characteristics

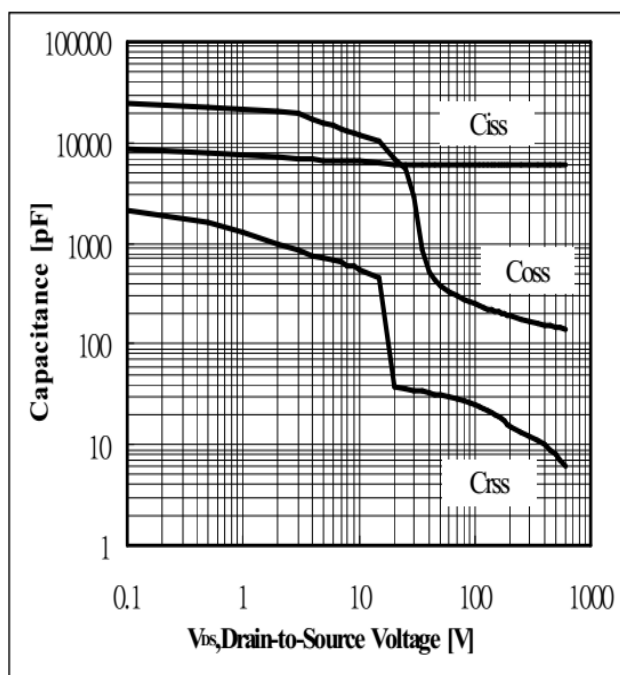

Fig 5. Typical Capacitance Vs. Drain-to-Source Voltage

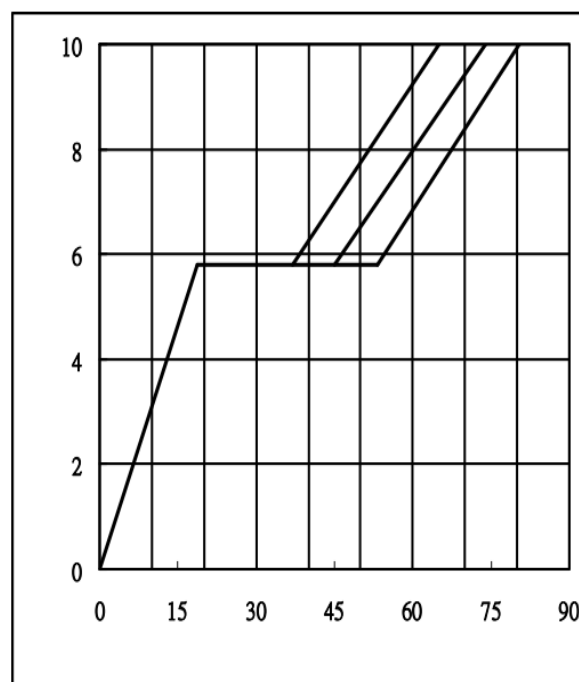
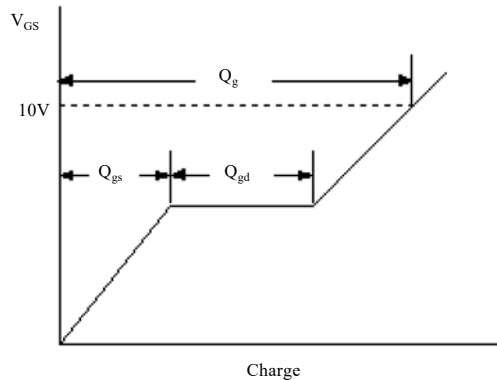
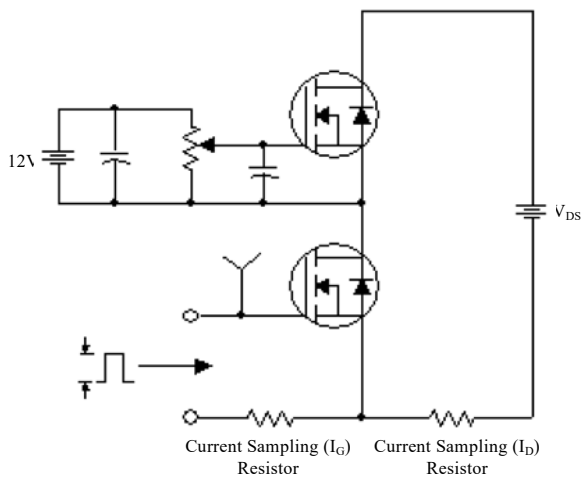
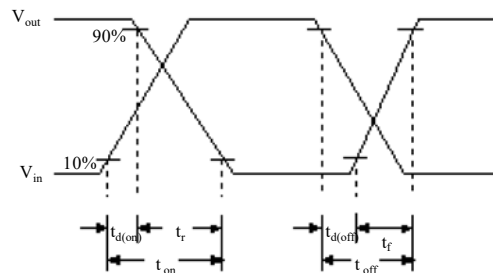
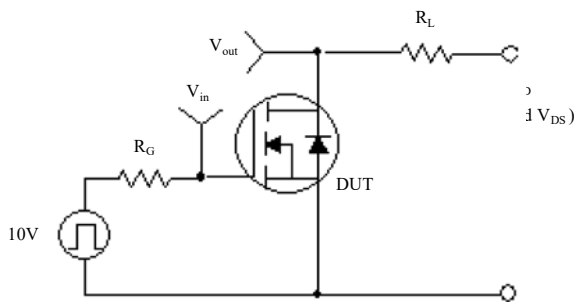

Fig 6. Typical Gate Charge Vs. Gate-to-Source Voltage

Gate Charge Test Circuit & Waveform



Resistive Switching Test Circuit & Waveforms



Unclamped Inductive Switching Test Circuit & Waveforms

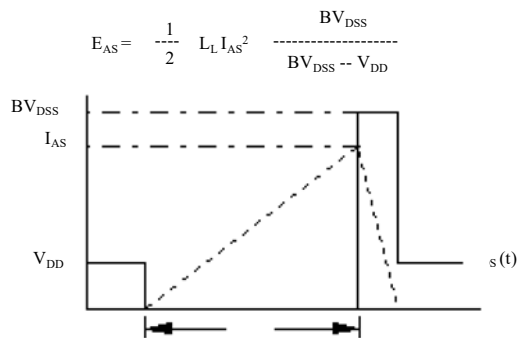
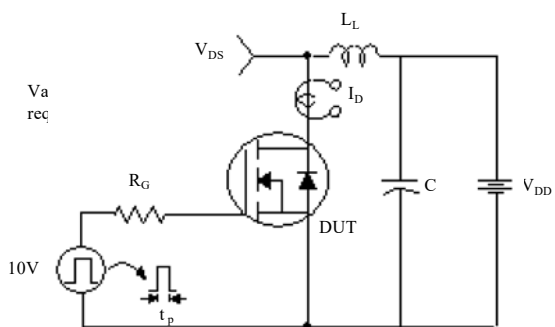

Peak Diode Recovery dv/dt Test Circuit & Waveforms

