

RED SLR2016
HIGH EFFICIENCY RED SLO2016
GREEN SLG2016
YELLOW SLY2016
X/Y Stackable 0.180" 4-Digit 5 x 7 Dot Matrix
Alphanumeric Intelligent Display® Devices
with Memory/Decoder/Driver

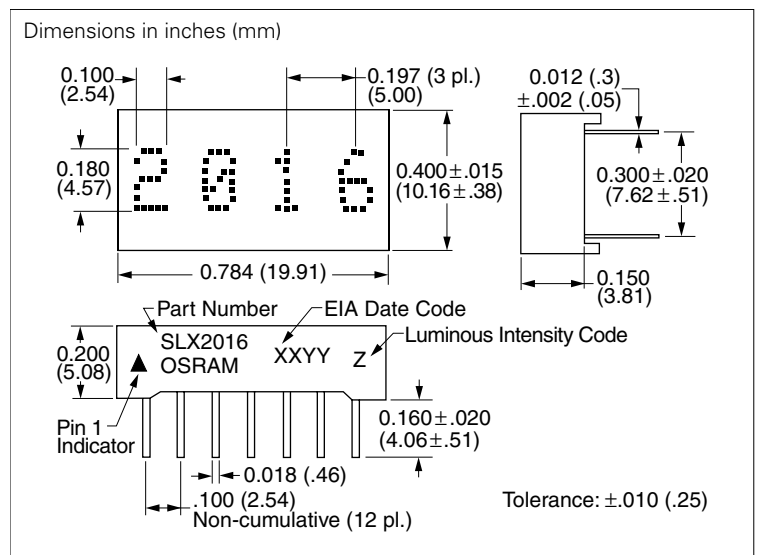
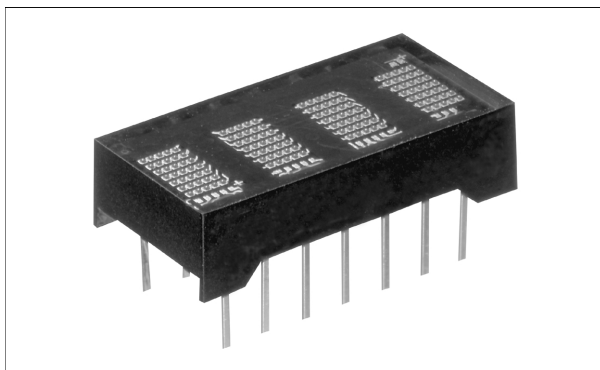

FEATURES

- **Very Close Multi-line Spacing, 0.4" Centers**
- **0.180" 5 x 7 Dot Matrix Characters**
- **128 Special ASCII Characters for English, German, Italian, Swedish, Danish, and Norwegian Languages**
- **Wide Viewing Angle: X axis 50° Maximum, Y Axis ±75° Maximum**
- **Fast Access Time, 110 ns at 25°C**
- **Full Size Display for Stationary Equipment**
- **Built-in Memory**
- **Built-in Character Generator**
- **Built-in Multiplex and LED Drive Circuitry**
- **Direct Access to Each Digit Independently and Asynchronously**
- **Clear Function that Clears Character Memory**
- **True Blanking for Intensity Dimming Applications**
- **End-stackable, 4-Character Package**
- **Intensity Coded for Display Uniformity**
- **Extended Operating Temperature Range: -40°C to +85°C**
- **Superior ESD Immunity**
- **100% Burned-in and Tested**
- **Wave Solderable**
- **TTL Compatible over Operating Temperature Range**

See Appnotes 18, 19, 22, and 23 at www.infineon.com/opto for additional information.

DESCRIPTION

The SLR/SLO/SLG/SLY2016 is a four digit 5 x 7 dot matrix display module with a built-in CMOS integrated circuit. This display is X/Y stackable.

The integrated circuit contains memory, a 128 ASCII ROM decoder, multiplexing circuitry and drivers. Data entry is asynchronous. A display system can be built using any number of SLR/SLO/SLG/SLY2016 since each digit can be addressed independently and will continue to display the character last stored until replaced by another.

System interconnection is very straightforward. Two address bits (A0, A1) are normally connected to the like-named inputs of all displays in the system.

Data lines are connected to all SLR/SLO/SLG/SLY2016s directly and in parallel as is the write line (\overline{WR}). The display will then behave as a write-only memory.

The SLR/SLO/SLG/SLY2016 has several features superior to competitive devices. 100% burn-in processing insures that the SLR/SLO/SLG/SLY2016 will function in more stressful assembly and use environments. True "blanking" allows the designer to dim the display for more flexibility of display presentation. Finally the CLR clear function will clear the ASCII character RAM.

DESCRIPTION (continued)

The character set consists of 128 special ASCII characters for English, German, Italian, Swedish, Danish, and Norwegian.

All products are 100% burned-in and tested, then subjected to out-going AQL's of .25% for brightness matching, visual alignment and dimensions, .065% for electrical and functional.

Maximum Ratings

DC Supply Voltage	-0.5 V to +7.0 Vdc
Input Voltage, Respect to GND (all inputs)	-0.5 V to $V_{CC} + 0.5$ Vdc
Operating Temperature	-40°C to +85°C
Storage Temperature	-40°C to +100°C
Relative Humidity at 85°C	85%
Maximum Solder Temperature, 0.063" (1.59 mm) below Seating Plane, $t < 5.0$ s	260°C

Optical Characteristics

Spectral Peak Wavelength

Red	660 nm typ.
HER	635 nm typ.
Green	565 nm typ.
Yellow	585 nm typ.

Digit Height..... 0.180" (4.57 mm)
Time Averaged Luminous Intensity ⁽¹⁾
at $V_{CC}=5.0$ V

Red.....	50 μ cd/LED min.
HER/Yellow	60 μ cd/LED min.
Green	75 μ cd/LED min.

LED to LED Intensity Matching, $V_{CC}=5.0$ V 1.8:1.0 max.

Viewing Angle (off normal axis)

Horizontal	$\pm 50^\circ$ max.
Vertical	$\pm 75^\circ$ max.

Note:

- 1) Peak luminous intensity values can be calculated by multiplying these values by 7.

Figure 1. Top View

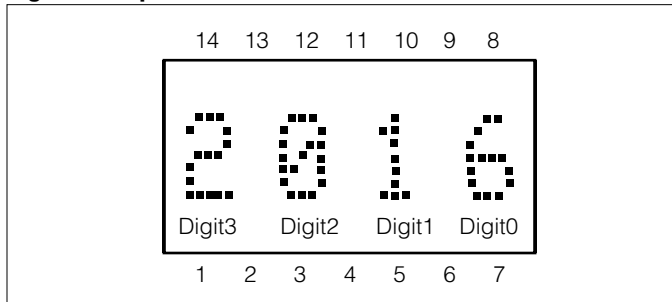

DC Characteristics at 25°C

Parameters	Min.	Typ.	Max.	Units	Conditions
V_{CC}	4.5	5.0	5.5	V	—
I_{CC} Blank	—	2.3	3.0	mA	$V_{CC}=5.0$ V
I_{CC} (80 dots on)	—	80	105	mA	$V_{CC}=5.0$ V
V_{IL} (all inputs)	—	—	0.8	V	4.5 V $< V_{CC} < 5.5$ V
V_{IH} (all inputs)	2.0	—	—	V	4.5 V $< V_{CC} < 5.5$ V
I_{IL} (all inputs)	25	—	100	μ A	4.5 V $< V_{CC} < 5.5$ V, $V_{IN}=0.8$ V

Pin Function

Pin	Function	Pin	Function
1	\overline{WR} Write	8	D3 Data
2	A1 Digit Select	9	D4 Data
3	A0 Digit Select	10	D5 Data
4	V_{CC}	11	D6 Data
5	D0 Data	12	\overline{BL} Display Blank
6	D1 Data	13	\overline{CLR} Clear
7	D2 Data	14	GND

Figure 2. Timing Characteristics—Write Cycle Waveforms

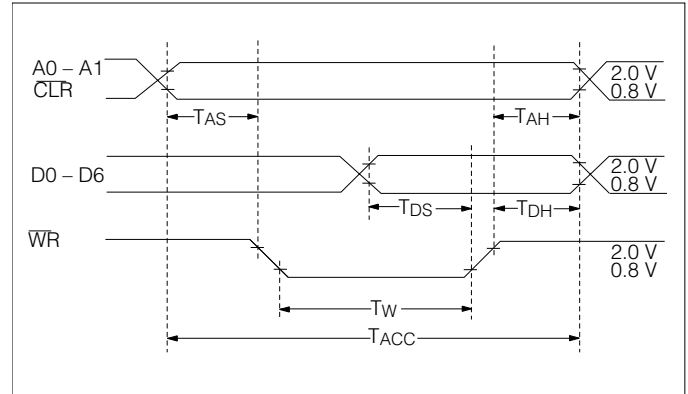

AC Characteristics (guaranteed minimum timing parameters at $V_{CC}=5.0\text{ V} \pm 0.5\text{ V}$)

Parameter	Symbol	-40°C	+25°C	+85°C	Unit
Address Set Up Time	T_{AS}	10	10	10	ns
Write Time	T_W	60	70	90	ns
Data Set Up Time	T_{DS}	20	30	50	ns
Address Hold Time	T_{AH}	20	30	40	ns
Data Hold Time	T_{DH}	20	30	40	ns
Access Time	$T_{ACC}^{(1)}$	90	110	140	ns
Clear Disable Time	$T_{CLR D}$	1.0	1.0	1.0	μs
Clear Time	T_{CLR}	1.0	1.0	1.0	ms

Note:

1) $T_{ACC} = \text{Set Up Time} + \text{Write Time} + \text{Hold Time}$

Loading Data

The desired data code (D0–D6) and digit address (A0, A1) must be held stable during the write cycle for storing new data.

Data entry may be asynchronous. Digit 0 is defined as right hand digit with $A1=A2=0$.

Clearing the entire internal four-digit memory can be accomplished by holding the clear (\overline{CLR}) low for 1.0 msec minimum. The clear function will clear the ASCII RAM. Loading an illegal data code will display a blank.

Typical Loading State Table

WR	A1	A0	D6	D5	D4	D3	D2	D1	D0	Digit			
										3	2	1	0
H			previously loaded display							G	R	E	Y
L	L	L	H	L	L	L	H	L	H	G	R	E	E
L	L	H	H	L	H	L	H	L	H	G	R	U	E
L	H	L	H	L	L	L	H	L	L	G	L	U	E
L	H	H	H	L	L	L	L	H	L	B	L	U	E
L	L	H	H	L	L	L	H	L	H	B	L	E	E
L	L	L	H	L	H	L	H	H	H	B	L	E	W
L	X	X	see character code							see char. set			

Display Blanking

Blank the display by loading a blank or space into each digit of the display or by using the (\overline{BL}) display blank input. Setting the (\overline{BL}) input low does not affect the contents of data memory.

A flashing circuit can easily be constructed using a 555 as table multivibrator. Figure 3 illustrates a circuit in which varying R1 (100K~10K) will have a flash rate of 1.0 Hz~10 Hz.

The display can be dimmed by pulse width modulating the (\overline{BL}) at a frequency sufficiently fast to not interfere with the internal clock. The dimming signal frequency should be 2.5 kHz or higher. Dimming the display also reduces power consumption.

An example of a simple dimming circuit using a 556 is illustrated in Figure 4. Adjusting potentiometer R3 will dim the display by changing the blanking pulse duty cycle.

Figure 3. Flashing Circuit Using a 555 and Flashing (Blanking) Timing

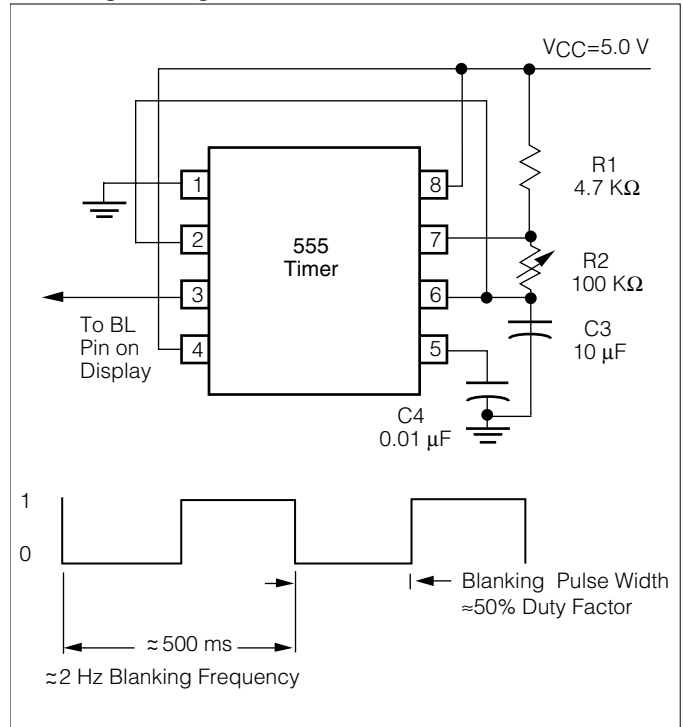

Figure 4. Dimming Circuit Using a 556 and Dimming (Blanking) Timing

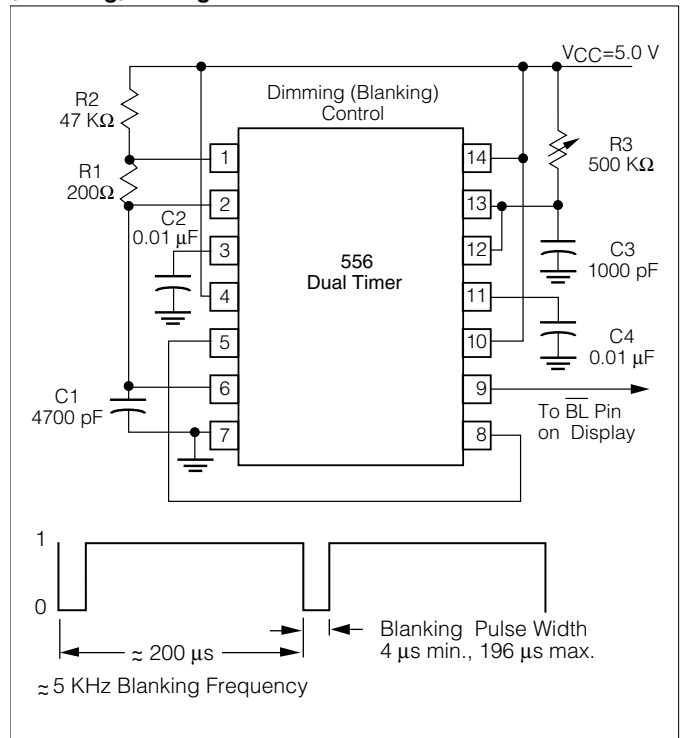

Figure 5. Character Set

ASCII CODE				D0	0	1	0	1	0	1	0	1	0	1	0	1	0	1		
				D1	0	0	1	1	0	0	1	1	0	0	1	1	0	0	1	1
				D2	0	0	0	0	1	1	1	1	0	0	0	0	1	1	1	1
				D3	0	0	0	0	0	0	0	0	1	1	1	1	1	1	1	1
D6	D5	D4	HEX	0	1	2	3	4	5	6	7	8	9	A	B	C	D	E	F	
0	0	0	0	0	1	2	3	4	5	6	7	8	9	A	B	C	D	E	F	
0	0	1	1	0	1	2	3	4	5	6	7	8	9	A	B	C	D	E	F	
0	1	0	2	0	1	2	3	4	5	6	7	8	9	A	B	C	D	E	F	
0	1	1	3	0	1	2	3	4	5	6	7	8	9	A	B	C	D	E	F	
1	0	0	4	0	1	2	3	4	5	6	7	8	9	A	B	C	D	E	F	
1	0	1	5	0	1	2	3	4	5	6	7	8	9	A	B	C	D	E	F	
1	1	0	6	0	1	2	3	4	5	6	7	8	9	A	B	C	D	E	F	
1	1	1	7	0	1	2	3	4	5	6	7	8	9	A	B	C	D	E	F	

Notes:

1. High=1 level
2. Low=0 level
3. Upon power up, the device will initialize in a random state.

Figure 6. Block Diagram

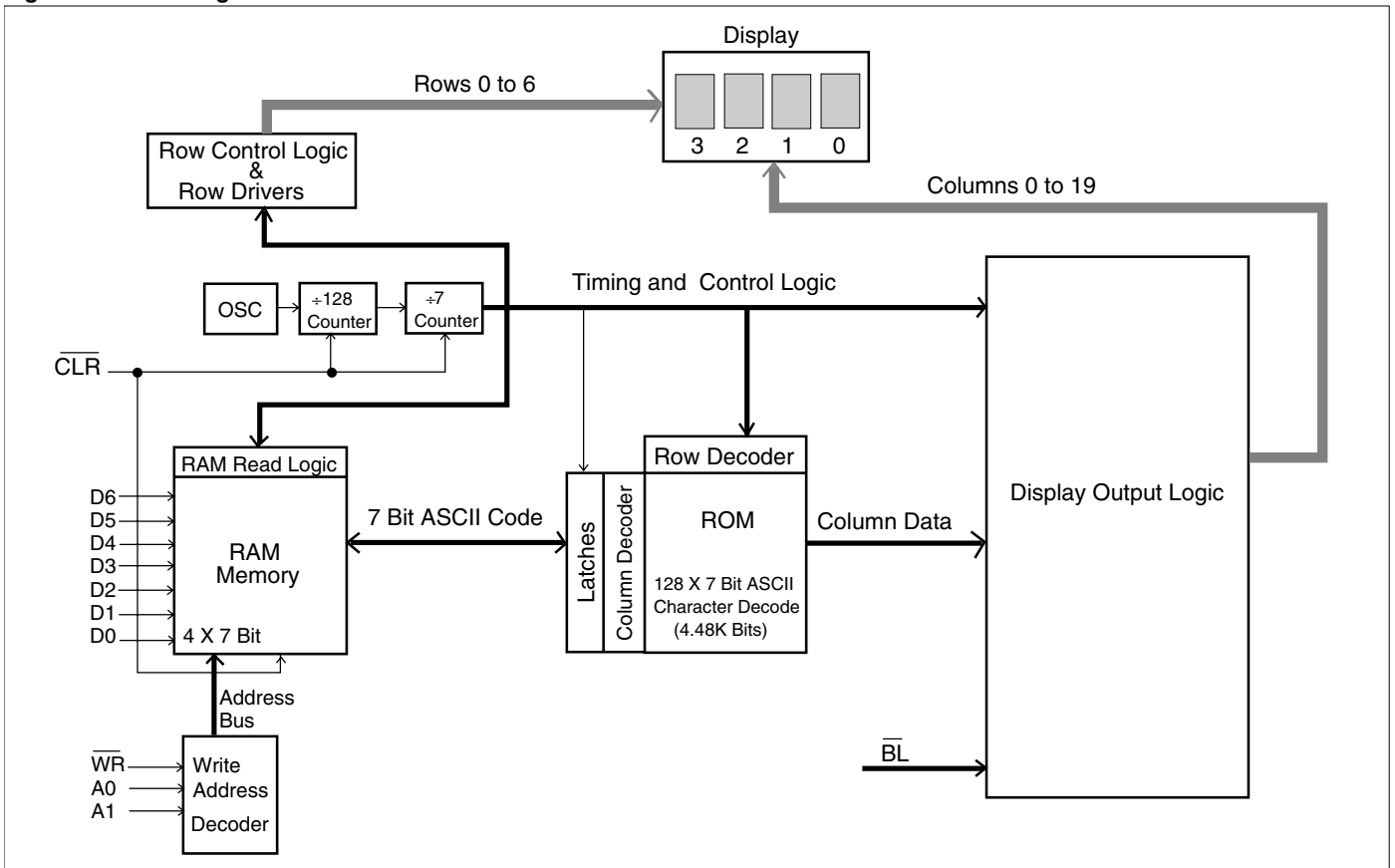

Design Considerations

For details on design and applications of the SLX2016 in multiple display systems, refer to Appnote 15 at www.infineon.com/opto.

Electrical & Mechanical Considerations

Voltage Transient Suppression

We recommend that the same power supply be used for the display and the components that interface with the display to avoid logic inputs higher than V_{CC} . Additionally, the LEDs may cause transients in the power supply line while they change display states. The common practice is to place .01 mF capacitors close to the displays across V_{CC} and GND, one for each display, and one 10 μ F capacitor for every second display.

ESD Protection

The CMOS IC of the SLX2016 is resistant to ESD damage and capable of withstanding discharges less than 2.0 kV. However, take all the standard precautions, normal for CMOS components. These include properly grounding personnel, tools, tables, and transport carriers that come in contact with unshielded parts. If these conditions are not, or cannot be met, keep the leads of the device shorted together or the parts in anti-static packaging.

Soldering Considerations

The SLX2016 can be hand soldered with SN63 solder using a grounded iron set to 260°C.

Wave soldering is also possible following these conditions: Pre-heat that does not exceed 93°C on the solder side of the PC board or a package surface temperature of 85°C. Water soluble organic acid flux (except carboxylic acid) or rosin-based RMA flux without alcohol can be used.

Wave temperature of 245°C \pm 5°C with a dwell between 1.5 sec. to 3.0 sec. Exposure to the wave should not exceed temperatures above 260°C for five seconds at 0.063" below the seating plane. The packages should not be immersed in the wave.

Post Solder Cleaning Procedures

The least offensive cleaning solution is hot D.I. water (60°C) for less than 15 minutes. Addition of mild saponifiers is acceptable. Do not use commercial dishwasher detergents.

For faster cleaning, solvents may be used. Carefully select any solvent as some may chemically attack the nylon package. Maximum exposure should not exceed two minutes at elevated temperatures. Acceptable solvents are TF (trichlorotrifluoroethane), TA, 111 Trichloroethane, and unheated acetone.

Note:

Acceptable commercial solvents are: Basic TF, Arklone, P. Genesolv, D. Genesolv DA, Blaco-Tron TF, Blaco-Tron TA, and Freon TA.

Unacceptable solvents contain alcohol, methanol, methylene chloride, ethanol, TP35, TCM, TMC, TMS+, TE, or TES. Since many commercial mixtures exist, contact a solvent vendor for chemical composition information. Some major solvent manufacturers are: Allied Chemical Corporation, Specialty Chemical Division, Morristown, NJ; Baron-Blakeslee, Chicago, IL; Dow Chemical, Midland, MI; E.I. DuPont de Nemours & Co., Wilmington, DE.

For further information refer to Appnotes 18 and 19 at www.infineon.com/opto.

An alternative to soldering and cleaning the display modules is to use sockets. Standard pin DIP sockets .300" wide with .100" centers work well for single displays. Multiple display assemblies are best handled by longer SIP sockets or DIP sockets when available for uniform package alignment. Socket manufacturers are Aries Electronics, Inc., Frenchtown, NJ; Garry Manufacturing, New Brunswick, NJ; Robinson-Nugent, New Albany, IN; and Samtec Electronic Hardware, New Albany, IN.

For further information refer to Appnote 22 at www.infineon.com/opto.

Optical Considerations

The .180" high characters of the SLX2016 gives readability up to eight feet. Proper filter selection enhances readability over this distance.

Filters enhance the contrast ratio between a lit LED and the character background intensifying the discrimination of different characters. The only limitation is cost. Take into consideration the ambient lighting environment for the best cost/benefit ratio for filters.

Incandescent (with almost no green) or fluorescent (with almost no red) lights do not have the flat spectral response of sunlight. Plastic band-pass filters are an inexpensive and effective way to strengthen contrast ratios. The SLR2016 is a standard red display and should be matched with long wavelength pass filter in the 600 nm to 620 nm range.

The SLO2016 is a high efficiency red display and should be matched with a long wavelength pass filter in the 470 nm to 590 nm range. The SLG/SLY2016 should be matched with a yellow-green band-pass filter that peaks at 565 nm. For displays of multiple colors, neutral density gray filters offer the best compromise.

Additional contrast enhancement is gained by shading the displays. Plastic band-pass filters with built-in louvers offer the next step up in contrast improvement. Plastic filters can be improved further with anti-reflective coatings to reduce glare. The trade-off is fuzzy characters. Mounting the filters close to the display reduces this effect. Take care not to overheat the plastic filter by allowing for proper air flow.

Optimal filter enhancements are gained by using circular polarized, anti-reflective, band-pass filters. Circular polarizing further enhances contrast by reducing the light that travels through the filter and reflects back off the display to less than 1%.

Several filter manufacturers supply quality filter materials. Some of them are: Panelgraphic Corporation, W. Caldwell, NJ; SGL Homalite, Wilmington, DE; 3M Company, Visual Products Division, St. Paul, MN; Polaroid Corporation, Polarizer Division, Cambridge, MA; Marks Polarized Corporation, Deer Park, NY; Hoya Optics, Inc., Fremont, CA.

One last note on mounting filters: recessing displays and bezel assemblies is an inexpensive way to provide a shading effect in overhead lighting situations. Several Bezel manufacturers are: R.M.F. Products, Batavia, IL; Nobex Components, Griffith Plastic Corp., Burlingame, CA; Photo Chemical Products of California, Santa Monica, CA; I.E.E.-Atlas, Van Nuys, CA.

Refer to Appnote 23 at www.infineon.com/opto for further information.