

Medium Pressure Digital & Analog Sensor

SM1291, SM1391, SM1491 Gauge and Differential Pressure Sensor



DESCRIPTION

The SM1X91 series are a medium pressure MEMS sensor family offering state-of-the-art pressure transducer technology and CMOS mixed signal processing technology to produce both digital & analog output, fully conditioned, multi-order pressure and temperature compensated outputs. This series provides two JEDEC standard SOIC-16 packages with dual vertical or horizontal port options. It is available in gauge, differential or asymmetric configurations. With dual porting, a reference measurement is possible to minimize errors due to changes in ambient pressure.

FEATURES

- 15 psi gauge, differential or asymmetric differential outputs
- Digital Accuracy: +/- 1 %FS; Analog Accuracy: +/- 1.5 %FS
- 16-bit digital, pressure calibrated and temperature compensated output
- I2C and analog output interface available
- Compensated temperature range: -20°C to 85°C
- Robust JEDEC SOIC-16 package for automated assembly
- Manufactured according to ISO9001 and ISO/TS 16949 standards

Combining the pressure sensor with a signal-conditioning ASIC in a single package simplifies the use of advanced silicon micro-machined pressure sensors. The pressure sensor can be mounted directly on a standard printed circuit board and a high level calibrated pressure signal can be acquired from the digital interface. This eliminates the need for additional circuitry, such as a compensation network or microcontroller containing a custom correction algorithm.

Customer-specified pressure ranges and supply voltages are available.

The SM1291, SM1391 and SM1491 series are shipped in sticks or tape & reel.

Medical	Industrial	Consumer
Sleep Apnea	Airflow Measurement	Sports Equipment
CPAP	Pneumatic Gauges	Appliances
Ventilators	Pressure Switches	
Gas Flow Instrumentation	Safety Cabinets	
Air Flow Monitors	Life Sciences	
Negative Pressure Wound Therapy	Gas Flow Instrumentation	

1. Absolute Maximum Ratings

All parameters are specified at VDD = 3.3 V / 5.0 V supply voltage at 25°C, unless otherwise noted.

No.	Characteristic	Symbol	Minimum	Maximum	Units
1	Compensated Temperature	T_{COMP}	-20	85	°C
2	Operating Temperature ^(a)	T_{OP}	-40	105	°C
3	Storage Temperature ^(a)	T_{STG}	-40	125	°C
4	Proof Pressure ^(a, c)	P_{Proof}		45	psi
5	Burst Pressure ^(a, d)	P_{Burst}		75	psi
6	Supply voltage	$V_{DD_{MIN/MAX}}$	-0.3	6	V
7	Media Compatibility ^(b)				

Notes:

- Tested on a sample basis.
- Clean, dry gas compatible with wetted materials. Wetted materials include silicon, epoxy, RTV, gold and aluminum.
- Proof pressure is defined as the maximum pressure to which the device can be taken and still perform within specifications after returning to the operating pressure range
- Burst pressure is the pressure at which the device suffers catastrophic failure resulting in pressure loss through the device.

2. ESD

All parameters are specified at VDD = 3.3 V / 5.0 V supply voltage at 25°C, unless otherwise noted.

No.	Description	Condition	Symbol	Min.	Typ.	Max.	Units
8	ESD HBM Protection at all Pins	AEC Q100-002 (HBM) chip level test	$V_{ESD(HBM)}$	-2		+2	kV

3. Electrical Characteristics

All parameters are specified at VDD = 5.0 V / 3.3 V DC supply voltage at 25°C, unless otherwise noted.

No.	Description	Symbol	Min.	Typ.	Max.	Units
9	Supply Voltage	V_{DD}	4.75	5.0	5.25	V
			3	3.3	3.6	
10	Low level input voltage at Digital I/O	$V_{IN,I2C,lo}$	-0.3		0.9	V
11	High level input voltage at Digital I/O	$V_{IN,I2C,hi}$	0.8*VDD		VDD + 0.3	V
12	Current Consumption with analog output			4.5		mA
13	Current Consumption without analog output			3.3		mA

4. External Components

No.	Description	Symbol	Min.	Typ.	Max.	Units
14	Supply bypass capacitor	C_{VDD}		100		nF

5. OPERATING CHARACTERISTICS TABLE

All parameters are specified at VDD = 5.0 V / 3.3 V DC supply voltage at 25°C, unless otherwise noted.

No.	Characteristic	Symbol	Minimum	Typical	Maximum	Units
15	Digital Pressure Output @ P_{MIN}	$DOUT_{MIN}$		-26214		Counts
16	Digital Pressure Output @ P_{MAX}	$DOUT_{MAX}$		26214		Counts
17	Digital Full Scale Span	DFS		52428		Counts
18	Resolution			16		Bits
19	Digital Output Accuracy ^(f, g, h)	DACC	-1		+1	%FS
20	Analog Pressure Output @ P_{MIN}	$AOUT_{MIN}$		10		%VDD
21	Analog Pressure Output @ P_{MAX}	$AOUT_{MAX}$		90		%VDD
22	Analog Full Scale Span	AFS		80		%VDD
23	Analog Output Accuracy ^(f, g, h)	AACC	-1.5		+1.5	%FS

Calibrated Pressure Ranges				
No.	Device Type	P_{MIN} (psi)	P_{MAX} (psi)	Comment
24	SM1291 – Gauge	0	+15	
25	SM1391 – Differential	-15	+15	Absolute value of P_{MIN} must match absolute value of P_{MAX}
26	SM1491 -- Asymmetric	-15 to 0	0 to +15	Delta between P_{MAX} and P_{MIN} must be at least 15psi

Notes:

- e. Only the typical values are shown here. However, the digital output values can be customized or changed upon request. Please refer to the tear sheet for the specific product to get updated information.
- f. The accuracy specification applies across the compensated temperature range. This specification includes the combination of linearity, repeatability, and hysteresis errors over pressure, temperature, and voltage.
- g. Maximum 10-year total output shift < ±1%FS based on 1000 hours of HTOL testing.
- h. For less demanding applications, devices with relaxed accuracy specifications are available.

***Custom calibration pressures and voltages are available to meet specific customer demands.**

5. Sensor Transfer Function

Digital Pressure Transfer Function

$$P_{read} = P_{min} + \frac{P_{DOUT_{read}} - P_{DOUT_{min}}}{P_{DOUT_{max}} - P_{DOUT_{min}}} (P_{max} - P_{min})$$

P_{min} and P_{max} are minimum and maximum rating pressure in specified pressure unit on the specification.

$P_{DOUT_{min}}$ and $P_{DOUT_{max}}$ are minimum and maximum digital counts on the specification.

$P_{DOUT_{read}}$ is digital reading from the output and P_{read} is the converted pressure output based on $P_{DOUT_{read}}$.

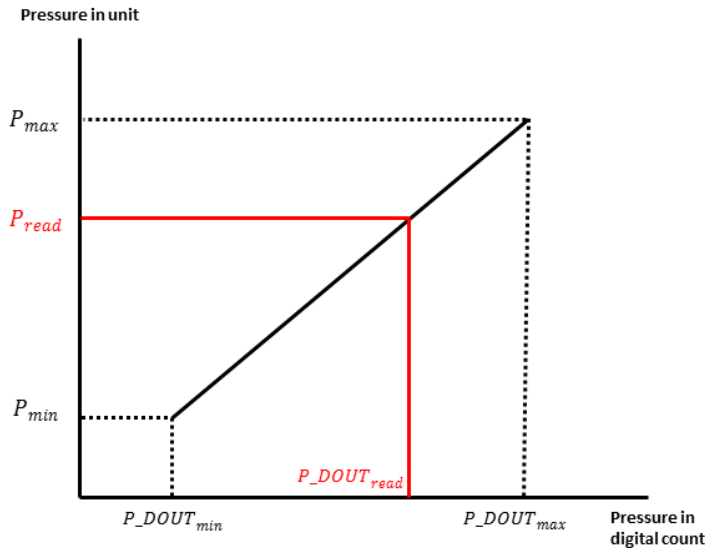

For example, the P_{min} and P_{max} for the sensor are specified as -15 psi and +15 psi. The $DOUT_{min}$ and $DOUT_{max}$ are -26214 and +26214. So,

$$P_{read} = -15 + \frac{DOUT_{read} + 26214}{52428} \times 30 \text{ psi}$$

6. Package Dimensions

SOIC-16 (C) Vertical Package Dimensions

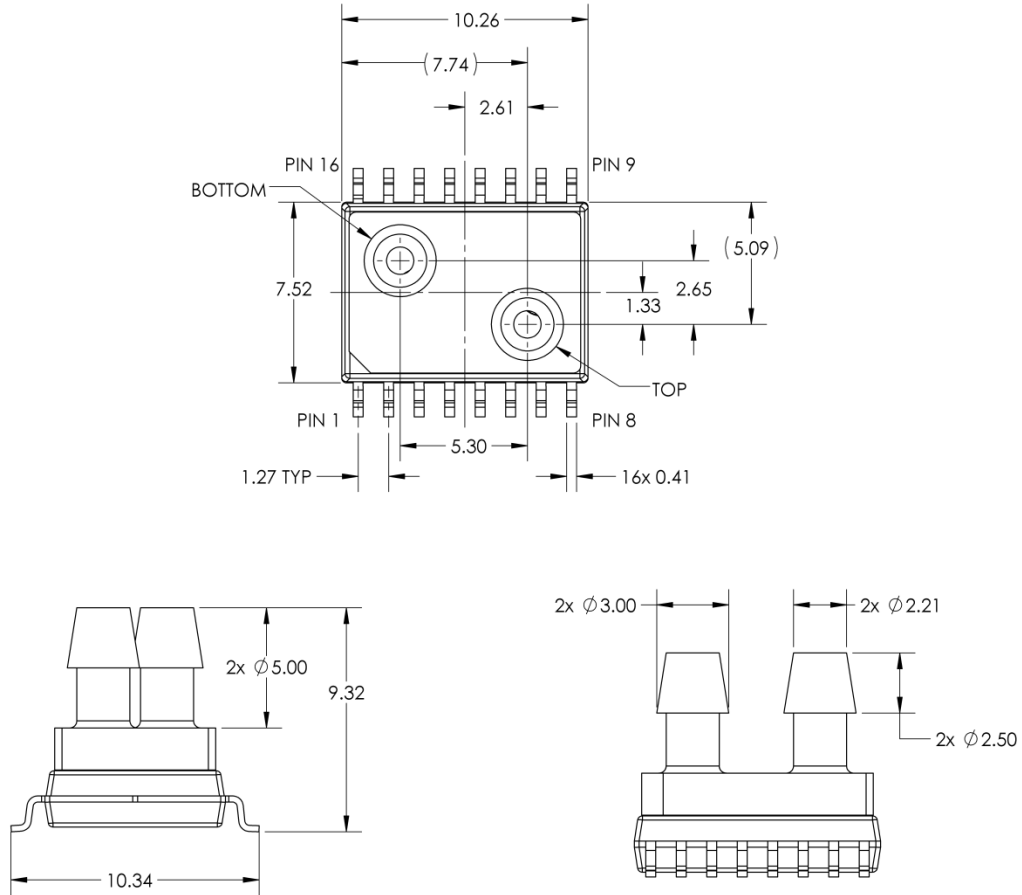

Notes:

- All dimensions in units of [mm]
- Moisture Sensitivity Level (MSL): Level 3
- Wetted materials: Silicon, glass, gold, aluminum, copper, silicone, epoxy, mold compound.

Part & Lot Number Identification

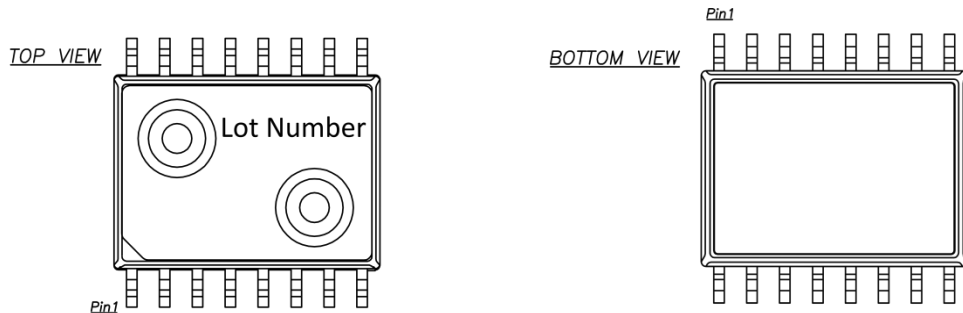

SOIC-16 Horizontal (B) Package Dimensions

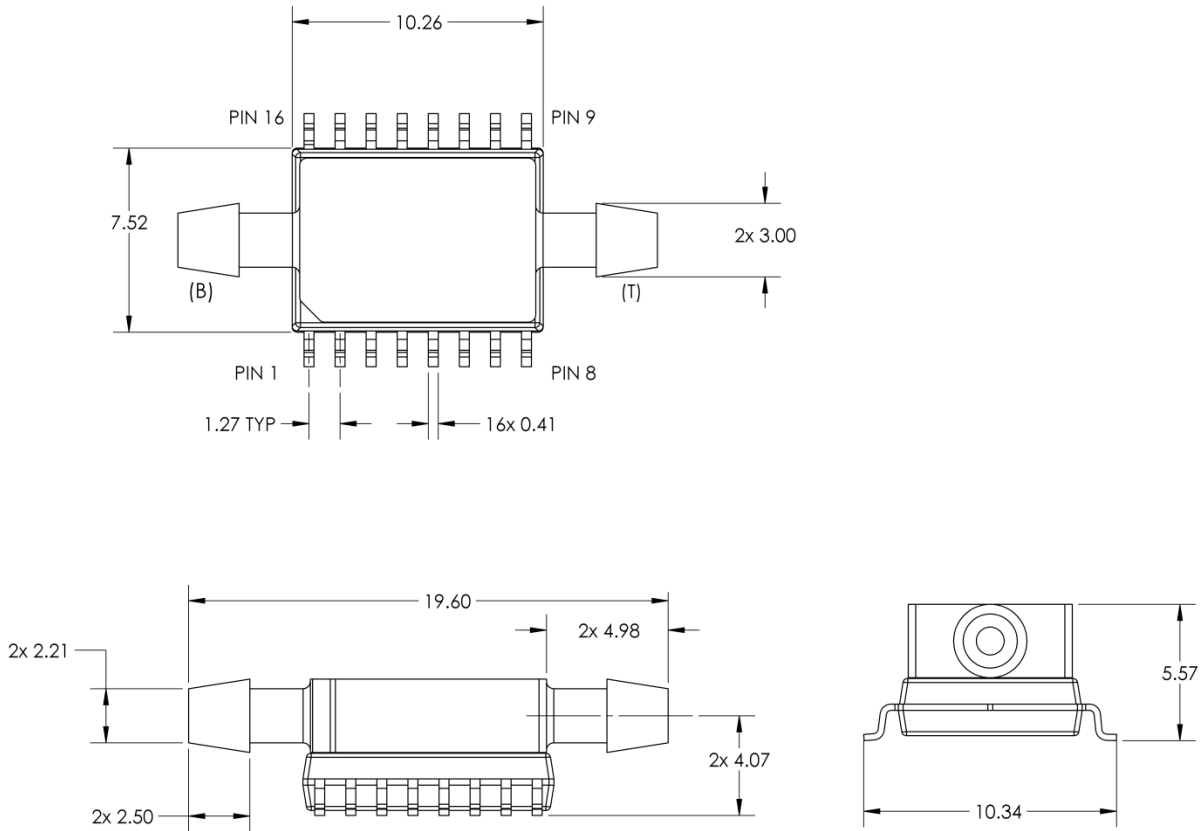

SOIC-16 (BG) Single Vertical Package Dimensions

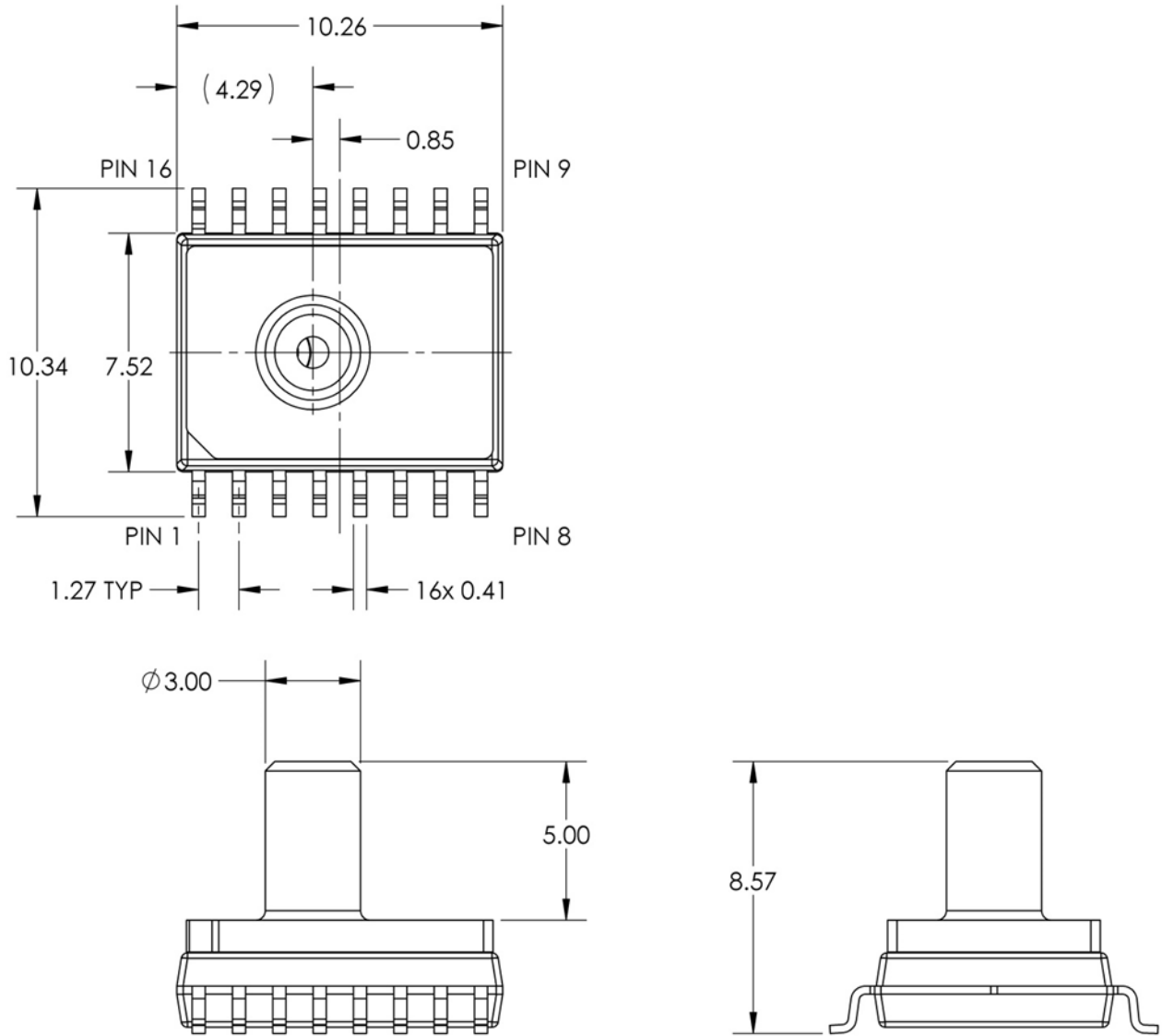

Notes:

- All dimensions in units of [mm].
- Moisture Sensitivity Level (MSL): Level 3
- Positive pressure applied to the port is resulting in a positive change in output. Pressure is applied to the backside of the die.

Qualification Standards

REACH Compliant
RoHS Compliant
PFOS/PFOA Compliant
For qualification specifications, please contact Sales at sales@si-micro.com



SM4x91 Family Applications Circuit

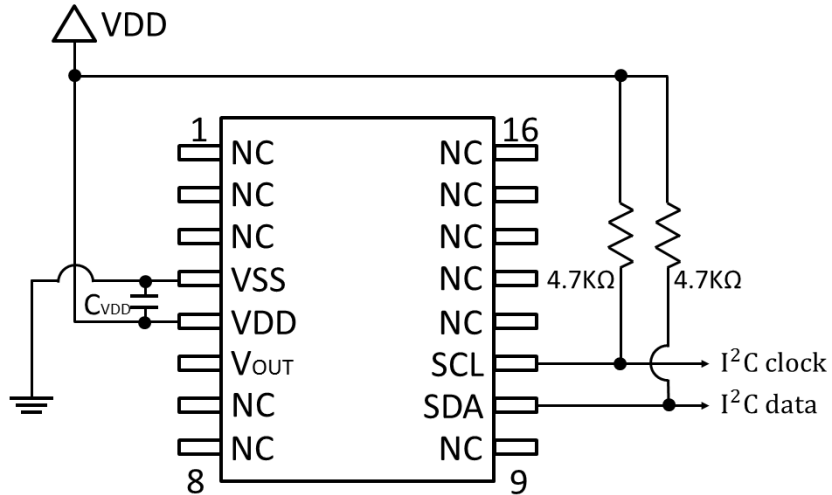

Pin No.	Pin function	Pin No.	Pin function
1	NC	9	NC
2	NC	10	SDA
3	NC	11	SCL
4	VSS	12	NC
5	VDD	13	NC
6	VOOUT (analog output)	14	NC
7	NC	15	NC
8	NC	16	NC

Ordering Information: Specific part number information is provided on a separate tear sheet for each product. The general part number ordering information is provided below:

Part Number Legend

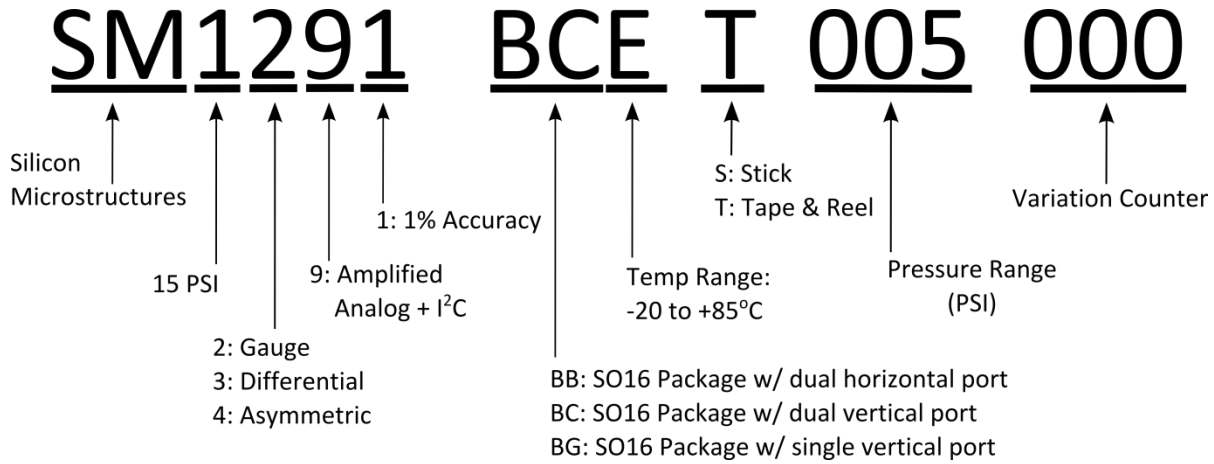

Silicon Microstructures Warranty and Disclaimer:

Silicon Microstructures, Inc. reserves the right to make changes without further notice to any products herein and to amend the contents of this data sheet at any time and at its sole discretion.

Information in this document is provided solely to enable software and system implementers to use Silicon Microstructures, Inc. products and/or services. No express or implied copyright licenses are granted hereunder to design or fabricate any silicon-based microstructures based on the information in this document.

Silicon Microstructures, Inc. makes no warranty, representation, or guarantee regarding the suitability of its products for any particular purpose, nor does Silicon Microstructures, Inc. assume any liability arising out of the application or use of any product or silicon-based microstructure, and specifically disclaims any and all liability, including without limitation consequential or incidental damages. "Typical" parameters which may be provided in Silicon Microstructure's data sheets and/or specifications can and do vary in different applications and actual performance may vary over time. All operating parameters, including "Typicals", must be validated for each customer application by customer's technical experts. Silicon Microstructures, Inc. does not convey any license under its patent rights nor the rights of others. Silicon Microstructures, Inc. makes no representation that the circuits are free of patent infringement. Silicon Microstructures, Inc. products are not designed, intended, or authorized for use as components in systems intended for surgical implant into the body, or other applications intended to support or sustain life, or for any other application in which the failure of the Silicon Microstructures, Inc. product could create a situation where personal injury or death may occur. Should Buyer purchase or use Silicon Microstructures, Inc. products for any such unintended or unauthorized application, Buyer shall indemnify and hold Silicon Microstructures, Inc. and its officers, employees, subsidiaries, affiliates, and distributors harmless against all claims, costs, damages, and expenses, and reasonable attorney fees arising out of, directly or indirectly, any claim of personal injury or death associated with such unintended or unauthorized use, even if such claim alleges that Silicon Microstructures, Inc. was negligent regarding the design or manufacture of the part.

Silicon Microstructures, Inc. warrants goods of its manufacture as being free of defective materials and faulty workmanship. Silicon Microstructures, Inc. standard product warranty applies unless agreed to otherwise by Silicon Microstructures, Inc. in writing; please refer to your order acknowledgement or contact Silicon Microstructures, Inc. directly for specific warranty details. If warranted goods are returned to Silicon Microstructures, Inc. during the period of coverage, Silicon Microstructures, Inc. will repair or replace, at its option, without charge those items it finds defective. The foregoing is buyer's sole remedy and is in lieu of all warranties, expressed or implied, including those of merchantability and fitness for a particular purpose. In no event shall Silicon Microstructures, Inc. be liable for consequential, special, or indirect damages.

While Silicon Microstructures, Inc. provides application assistance personally, through its literature and the Silicon Microstructures, Inc. website, it is up to the customer to determine the suitability of the product for its specific application. The information supplied by Silicon Microstructures, Inc. is believed to be accurate and reliable as of this printing. However, Silicon Microstructures, Inc. assumes no responsibility for its use. Silicon Microstructures, Inc. assumes no responsibility for any inaccuracies and/or errors in this publication and reserves the right to make changes without further notice to any products or specifications herein

Silicon Microstructures, Inc.TM and the Silicon Microstructures, Inc. logo are trademarks of Silicon Microstructures, Inc. All other service or product names are the property of their respective owners.

© Silicon Microstructures, Inc. 2001-2018. All rights reserved.