



SM320A thru SM3200A



Schottky Barrier Rectifiers



DO-214AC(SMA)

Primary Characteristics		
I_F	3	A
V_{RRM}	20~200	V
I_{FSM}	80	A
V_F	0.50, 0.7, 0.85, 0.87, 0.90	V
$T_J \text{ max}$	125, 150	°C

Features
<ul style="list-style-type: none"> • High current capability • High surge current capability • Low reverse current • Component in accordance to RoHS 2002/95/EC

Mechanical Data
<ul style="list-style-type: none"> • Cases:DO-214AC(SMA) • Case Material: Molded Plastic. UL Flammability Classification Rating 94V-0 • Terminals: Lead free Plating (Tin Finish) Solderable per MIL-STD-202, Method 208 • Polarity: Cathode Band • Weight: 0.062 grams (approximate)

Ordering Information			
Part No.	Remark	Package	Packing
SM3xxA	General	SMA	5000 / Tape & Reel
SM3xxA-H	Halogen Free		
SM3xxA-Q	AEC-Q101 qualified		

Maximum Ratings (TA=25°C unless otherwise noted)												
PARAMETER	SYMBOL	SM 320A	SM 330A	SM 340A	SM 350A	SM 360A	SM 380A	SM 3100A	SM 3150A	SM 3200A	UNIT	
Maximum repetitive peak reverse voltage	V_{RRM}	20	30	40	50	60	80	100	150	200	V	
Maximum RMS voltage	V_{RMS}	14	21	28	35	42	56	70	105	140	V	
Maximum DC blocking voltage	V_{DC}	20	30	40	50	60	80	100	150	200	V	
Maximum average forward rectified current	I_F	3									A	
Peak forward surge current, 8.3ms single half sine-wave superimposed on rated load	I_{FSM}	80									A	
Maximum Instantaneous Forward Voltage IF=3A @ 25°C	V_F	0.50		0.70			0.85		0.87	0.90	V	
Maximum DC Reverse Current @ TA=25°C at Rated DC Blocking Voltage @ TA=100°C	I_R	0.5 10					0.2 5.0				mA	
Typical Junction Capacitance(NOTE1)	C_j	150					100		80			pF
Typical Thermal Resistance	$R_{\theta JC}$	25									°C/W	
Operating Temperature Range	T_J	-55 to +125					-55 to +150					°C
Storage Temperature Range	T_{STG}	-55 to +150									°C	
Marking Code		SM 320A	SM 330A	SM 340A	SM 350A	SM 360A	SM 380A	SM 3100A	SM 3150A	SM 3200A		

NOTES:

1.Measured at 1.0MHZ and applied reverse voltage of 4.0V DC



Schottky Barrier Rectifiers

Rating and Characteristics Curvers

FIG. 1-Typical Forward Current Derating Curve

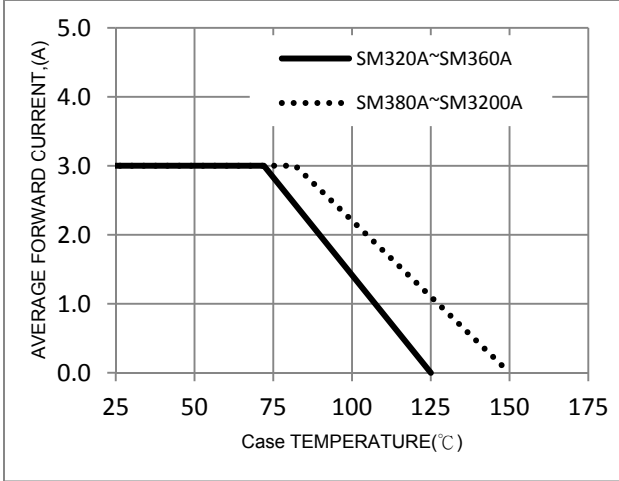

FIG. 2-Typical Forward Characteristics

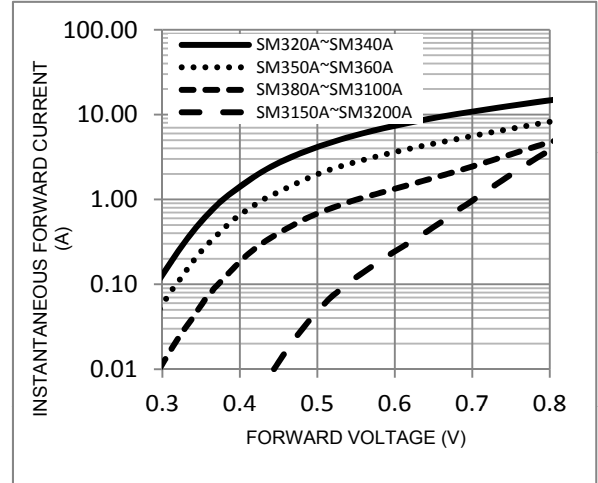

FIG. 3-Maximum Non-Repetitive Forward Surge Current

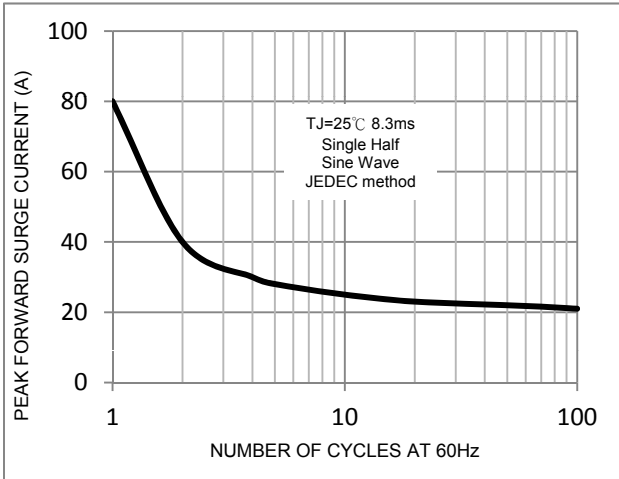

FIG. 4-Typical Reverse Characteristics

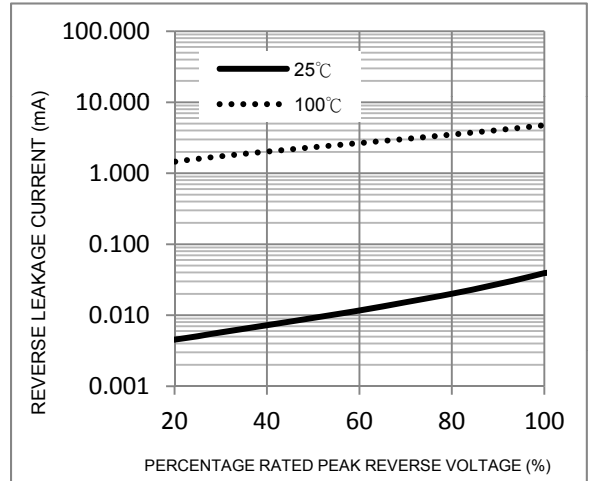
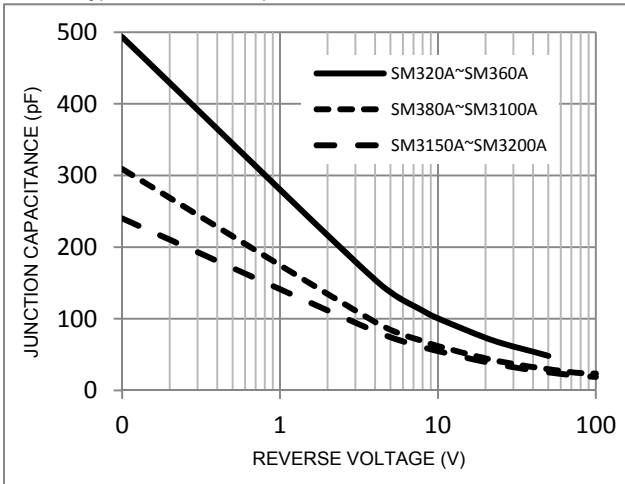

FIG. 5-Typical Junction Capacitance





SM320A thru SM3200A



Schottky Barrier Rectifiers

Package Outline Dimensions

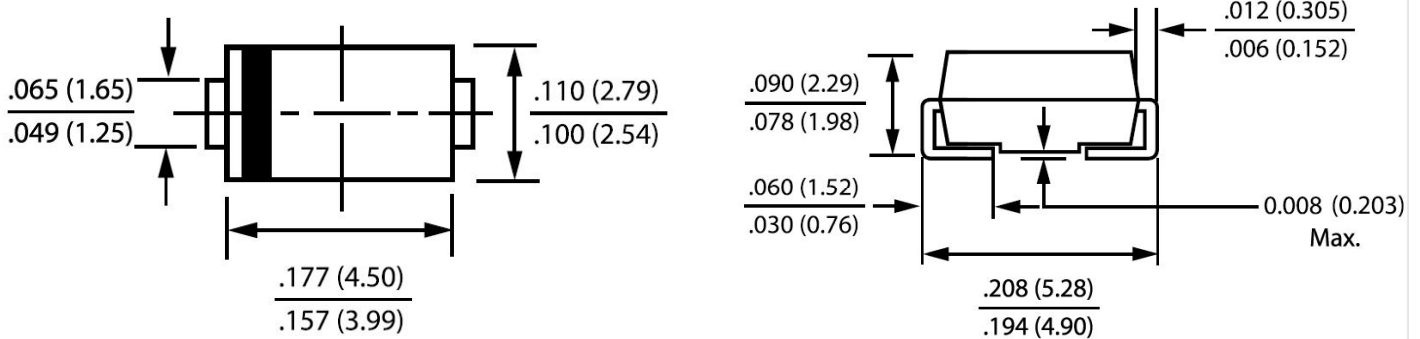

DO-214AC(SMA)

Dimensions in inches and (millimeters)

Marking Information

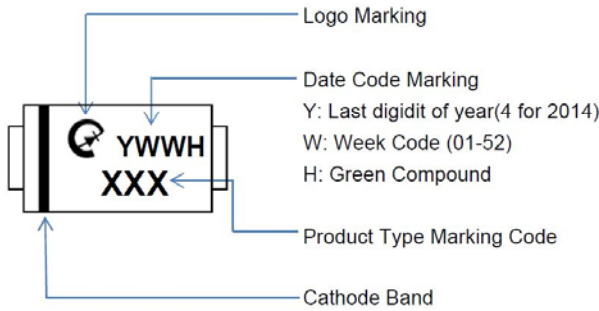

Suggested Pad Layout

Dimension	Outline	SMA (DO-214AC)
A		6.50
B		1.50
C		1.70
D		2.50
E		4.00

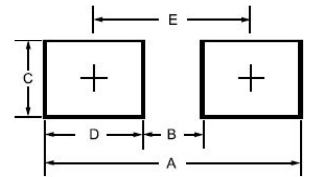

Tap & Reel Specification

ITEM	SYMBOL	SMA(mm) DO-214AC
Carrier width	A	2.9(max)
Carrier length	B	5.9(max)
Carrier depth	C	2.66(max)
Sprocket hole	d	1.50±0.1
Reel outside diameter	D	330±2.0
Feed hole diameter	D0	13.5±1
Reel inner diameter	D1	50 (min.)
Sprocket hole position	E	1.75±0.1
Punch hole position	F	5.5±0.05
Sprocket hole pitch	P	4.0±0.1
Sprocket hole pitch	Po	4.0±0.1
Embossment center	P1	2.0±0.05
Overall tape thickness	T	0.6 (max)
Tape width	W	12.0±0.3
Reel width	W2	18.4 (max)
Reel width	W1	14.4 (max)

