

DC to DC Converter Controller

FEATURES

- operation from 3.0 to 40V input
- short circuit current limiting
- low standby current
- output switch current of 1.5A
- output voltage adjustable
- frequency of operation from 100Hz to 100KHz
- step-up, step-down or inverting switching regulators
- current limiting

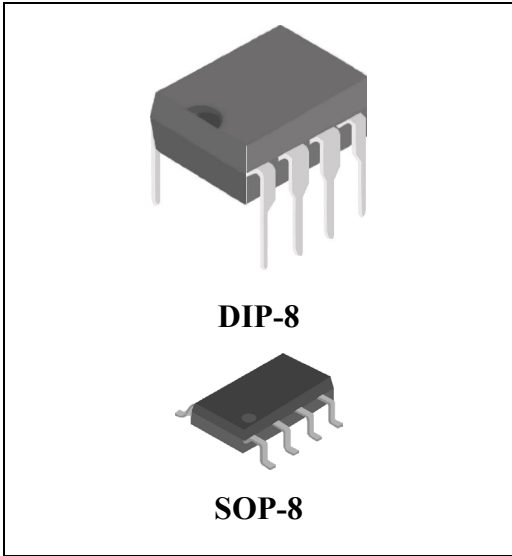

PRODUCT DESCRIPTION

The SM34063 is a monolithic control circuit containing the primary functions required for DC-to-DC converters. This device consists of an internal temperature compensated reference, comparator, controlled duty cycle oscillator with an active current limit circuit, driver and high current output switch.

This device was specifically designed to be incorporated in Step-Down and Step-Up and Voltage-inverting applications with a minimum number of external components.

PIN CONFIGURATION

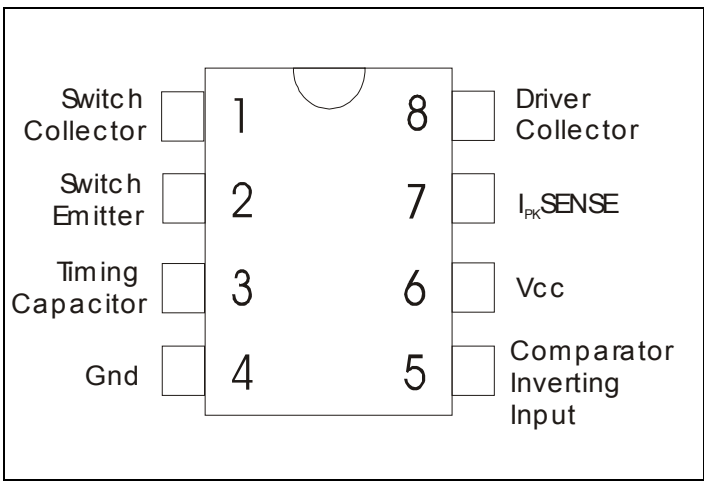

ORDERING INFORMATION

Part Number	Operating Temperature Range	Package Type
SM34063N	0°C~+70°C	DIP-8
SM34063M	0°C~+70°C	SOP-8

DC to DC Converter Controller

ABSOLUTE MAXIMUM RATING

Characteristic	Symbol	Value	Unit
Power Supply Voltage	V_{CC}	40	V
Comparator Input Voltage Range	V_{IR}	-0.3 to +40	V
Switch Collector Voltage	$V_{C(switch)}$	40	V
Switch Emitter Voltage ($V_{Pin1}=40V$)	$V_{E(switch)}$	40	V
Switch Collector to Emitter Voltage	$V_{CE(switch)}$	40	V
Driver Collector Voltage	$V_{C(driver)}$	40	V
Driver Collector Current (Note 1)	$I_{C(driver)}$	100	mA
Switch Current	I_{SW}	1.5	A
Power Dissipation and Thermal Characteristics			
Plastic Package $T_A=25^{\circ}C$	P_D	1.25	W
Thermal Resistance	$R_{\theta JA}$	100	$^{\circ}C/W$
SOIC Package $T_A=25^{\circ}C$	P_D	0.625	W
Thermal Resistance	$R_{\theta JA}$	100	$^{\circ}C/W$
Operating Junction Temperature	T_J	+150	$^{\circ}C$
Operating Ambient Temperature Range	T_A	0 to +70	$^{\circ}C$
Storage Temperature Range	T_{stg}	-65 to +150	$^{\circ}C$

NOTES: 1. Maximum package power dissipation limits must be observed. 2. ESD data available upon request.

BLOCK DIAGRAM

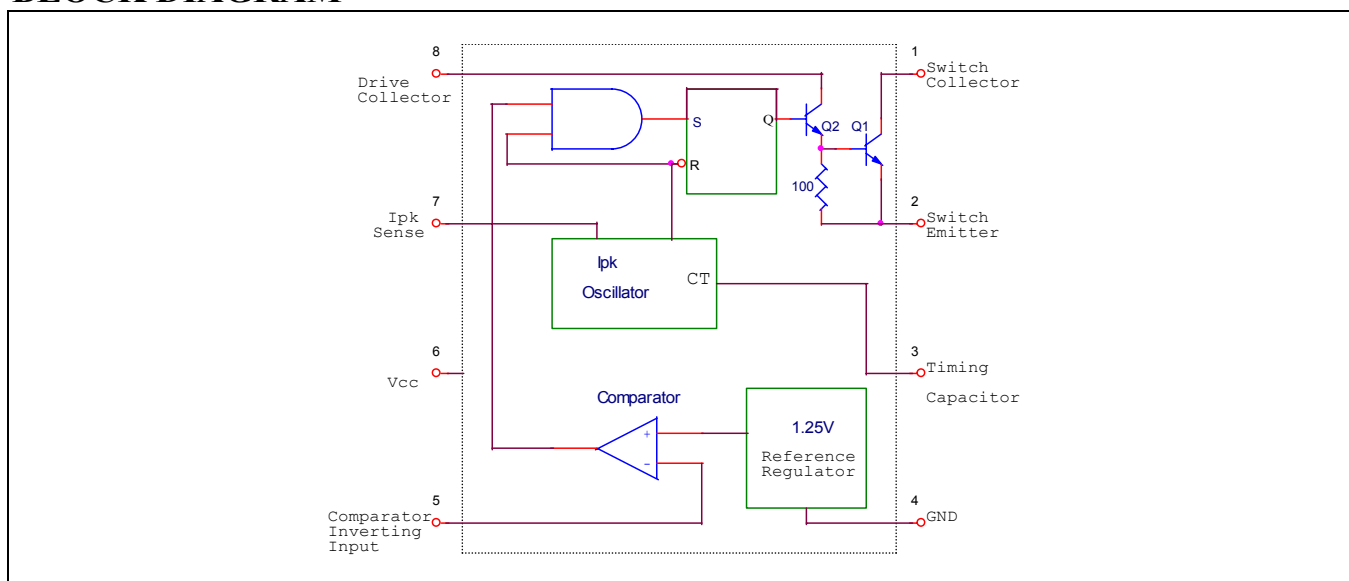

DC to DC Converter Controller

ELECTRICAL CHARACTERISTICS ($V_{CC}=5.0V$, $T_A=T_{low}$ to T_{high} [Note1], unless otherwise specified.)

Characteristics	Symbol	Min	Typ	Max	Unit
-----------------	--------	-----	-----	-----	------

OSCILLATOR

Frequency ($V_{Pin 5}=0V$, $C_T=1.0nF$, $T_A=25^\circ C$)	f_{OSC}	24	33	42	kHz
Charge Current ($V_{CC}=5.0V$ to $40V$, $T_A=25^\circ C$)	I_{chg}	24	35	42	μA
Discharge Current ($V_{CC}=5.0V$ to $40V$, $T_A=25^\circ C$)	I_{dischg}	140	220	260	μA
Discharge to Charge Current Ratio (Pin 7 to V_{CC} , $T_A=25^\circ C$)	I_{dischg} / I_{chg}	5.2	6.5	7.5	-
Current Limit Sense Voltage ($I_{chg}=I_{dischg}$, $T_A=25^\circ C$)	$V_{ipk(sence)}$	250	300	350	mV

OUTPUT SWITCH (NOTE 2)

Saturation Voltage, Darlington Connection (Note 3) ($I_{SW}=1.0A$, Pins 1, 8 connected)	$V_{CE(sat)}$	-	1.0	1.3	V
Saturation Voltage, Darlington Connection ($I_{SW}=1.0A$, $R_{Pin 8}=82\Omega$ to V_{CC} , Forced $\beta \cong 20$)	$V_{CE(sat)}$	-	0.45	0.7	V
DC Current Gain ($I_{SW}=1.0A$, $V_{CE}=5.0V$, $T_A=25^\circ C$)	h_{FE}	50	75	-	-
Collector Off-State Current ($V_{CE}=40V$)	$I_{C(off)}$	-	0.01	100	μA

COMPARATOR

Threshold Voltage ($T_A=25^\circ C$) ($T_A=T_{low}$ to T_{high})	V_{th}	1.238 1.225	1.25 -	1.262 1.275	V
Threshold Voltage Line Regulation ($V_{CC}=3.0V$ to $40V$)	Reg_{line}	-	1.4	5.0	mV
Input Bias Current ($V_{in}=0V$)	I_{IB}	-	-20	-400	nA

TOTAL DEVICE

Supply Current ($V_{CC}=5.0V$ to $40V$, $C_T=1.0nF$, Pin 7= V_{CC} , $V_{Pin 5}>V_{th}$, Pin 2=Gnd, remaining pins open)	I_{CC}	-	-	4.0	mA
--	----------	---	---	-----	----

- NOTES:
- $T_{low}=0^\circ C$ $T_{high}=+70^\circ C$
 - Low duty cycle pulse techniques are used during test to maintain junction temperature as close to ambient temperature as possible.
 - If the output switch is driven into hard saturation (non-Darlington) at low switch currents ($\leq 300mA$) and high driver currents ($\geq 30mA$), it may take up to $2.0\mu s$ for it to come out of saturation. This condition will shorten the off time at frequencies $\geq 30kHz$, and is magnified at high temperature. This condition does not occur with a Darlington configuration, since the output switch cannot saturate. If a non-Darlington configuration is used, the following output drive condition is recommended:

$$\text{Forced } \beta \text{ of output switch: } \frac{I_C \text{ output}}{I_C \text{ driver} - 7.0mA} \geq 10$$

*The 100Ω resistor in the emitter of the driver device requires about $7.0mA$ before the output switch conducts.

DC to DC Converter Controller

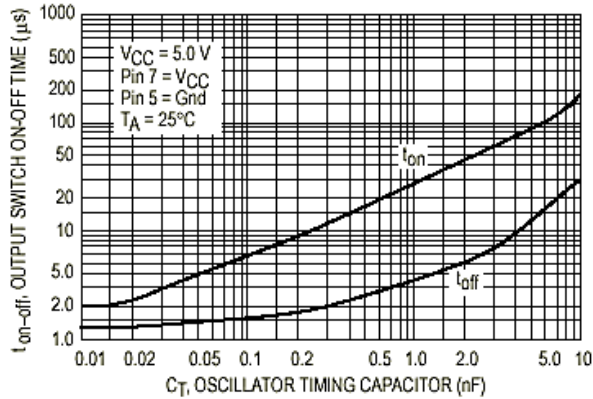

Fig 1. Output Switch On-Off Time versus Oscillator Timing Capacitor

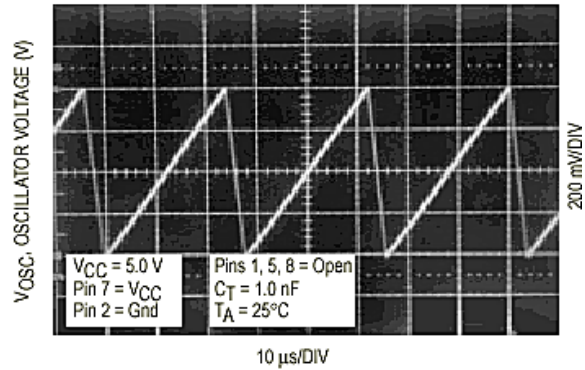

Fig 2. Timing Capacitor Waveform

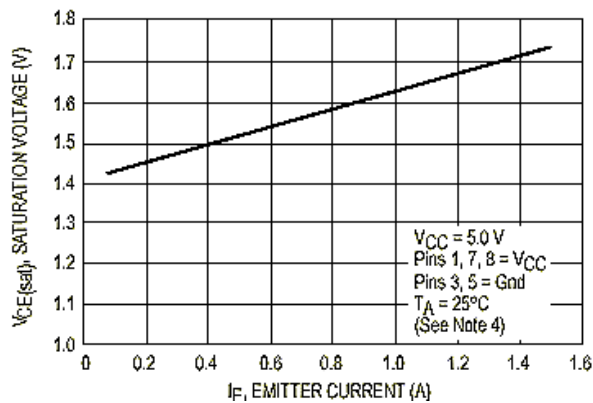

Fig 3. Emitter Follower Configuration Output Saturation Voltage versus Emitter Current

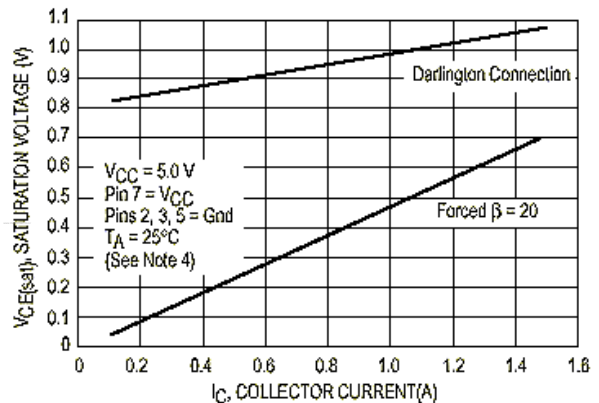

Fig 4. Common Emitter Configuration Output Switch Saturation Voltage versus Collector Current

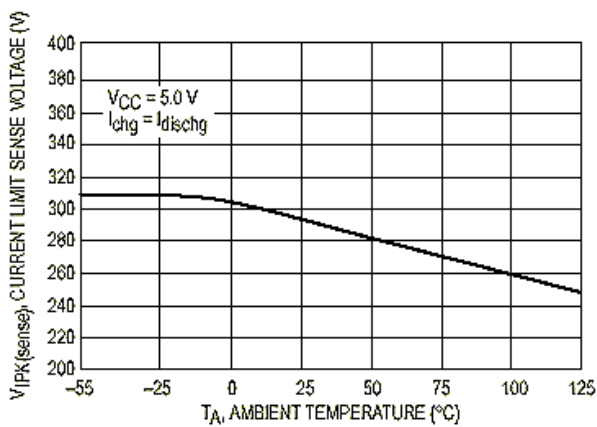

Fig 5. Current Limit Sense Voltage versus Temperature

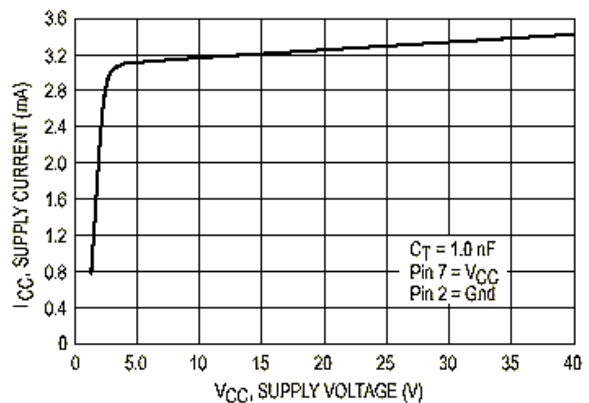
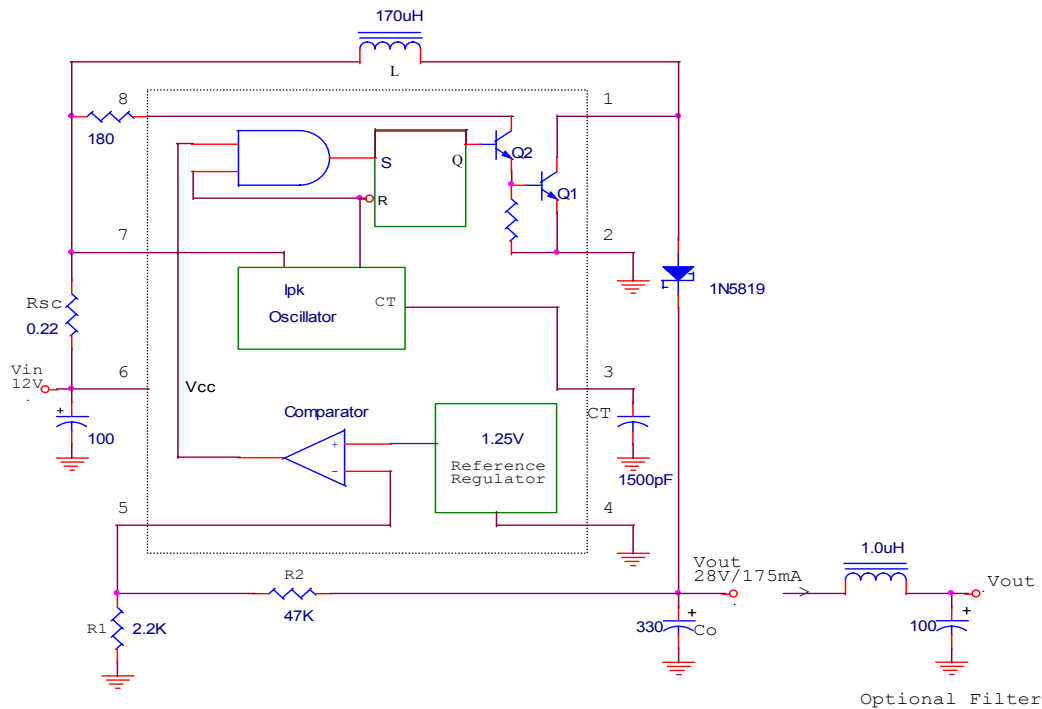

Fig 6. Standby Supply Current versus Supply Voltage

DC to DC Converter Controller



Optional Filter

Test	Conditions	Results
Line Regulation	$V_{in}=8.0\text{ V to }16\text{ V}, I_O=175\text{ mA}$	$30\text{ mV}=\pm 0.05\%$
Load Regulation	$V_{in}=12\text{ V}, I_O=75\text{ mA to }175\text{ mA}$	$10\text{ mV}=\pm 0.017\%$
Output Ripple	$V_{in}=12\text{ V}, I_O=175\text{ mA}$	400 mVpp
Efficiency	$V_{in}=12\text{ V}, I_O=175\text{ mA}$	87.7%
Output Ripple With Optional Filter	$V_{in}=12\text{ V}, I_O=175\text{ mA}$	40 mVpp

Fig 7. Step-Up Converter

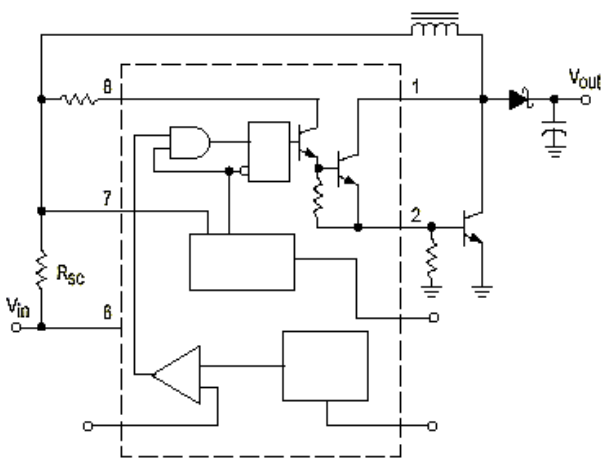

8-1. External NPN Switch

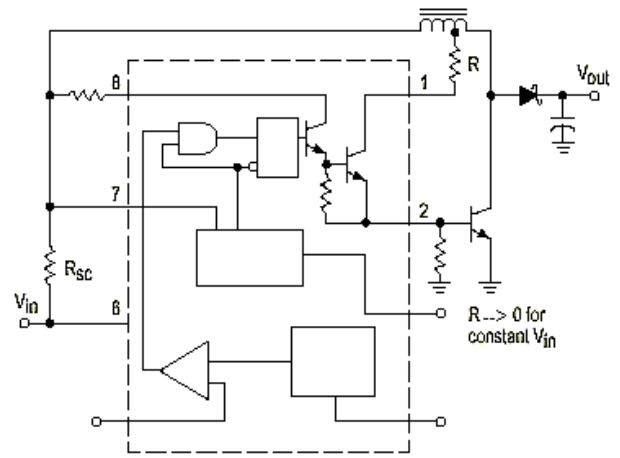

8-2. External NPN Saturated Switch(See Note 5)

DC to DC Converter Controller

Fig 8. External Current Boost Connections for I_C Peak Greater than 1.5A

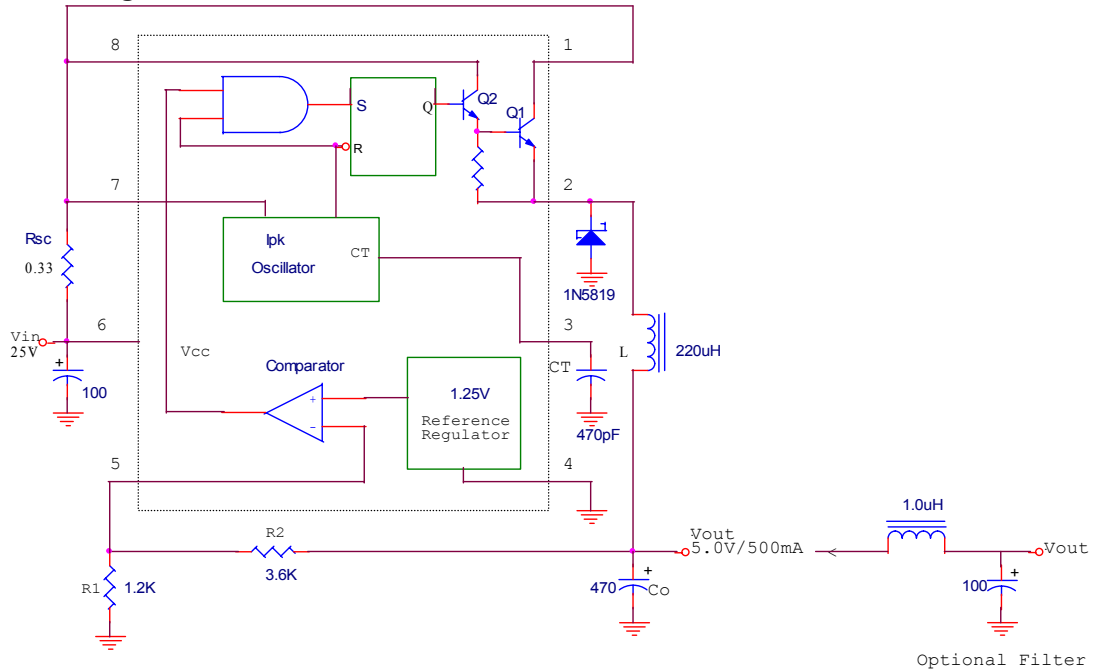

Test	Conditions	Results
Line Regulation	$V_{in}=15\text{ V to }25\text{ V}, I_O=500\text{ mA}$	12 mV \pm 0.12%
Load Regulation	$V_{in}=25\text{ V}, I_O=50\text{ mA to }500\text{ mA}$	3.0 mV \pm 0.03%
Output Ripple	$V_{in}=25\text{ V}, I_O=500\text{ mA}$	120 mVpp
Short Circuit Current	$V_{in}=25\text{ V}, R_L=0.1\ \Omega$	1.1 A
Efficiency	$V_{in}=25\text{ V}, I_O=500\text{ mA}$	83.7%
Output Ripple With Optional Filter	$V_{in}=25\text{ V}, I_O=500\text{ mA}$	40 mVpp

Fig 9. Step-Down Converter

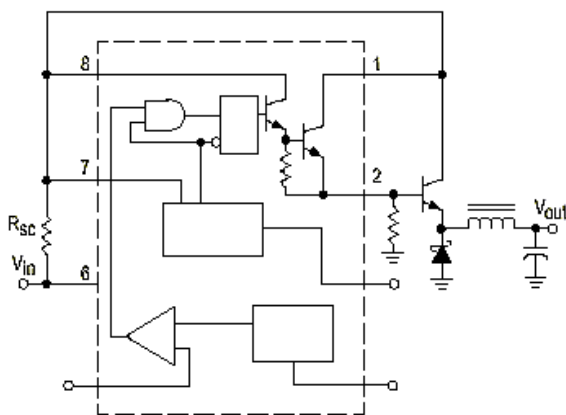

10-1. External NPN Switch

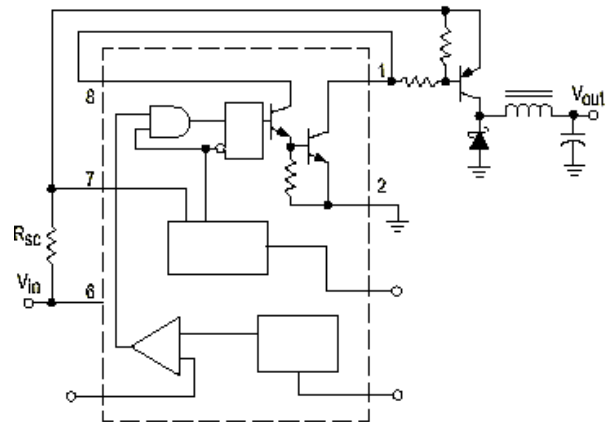

10-2. External PNP Saturated Switch

DC to DC Converter Controller

Fig 10. External Current Boost Connections for I_C Peak Greater than 1.5A

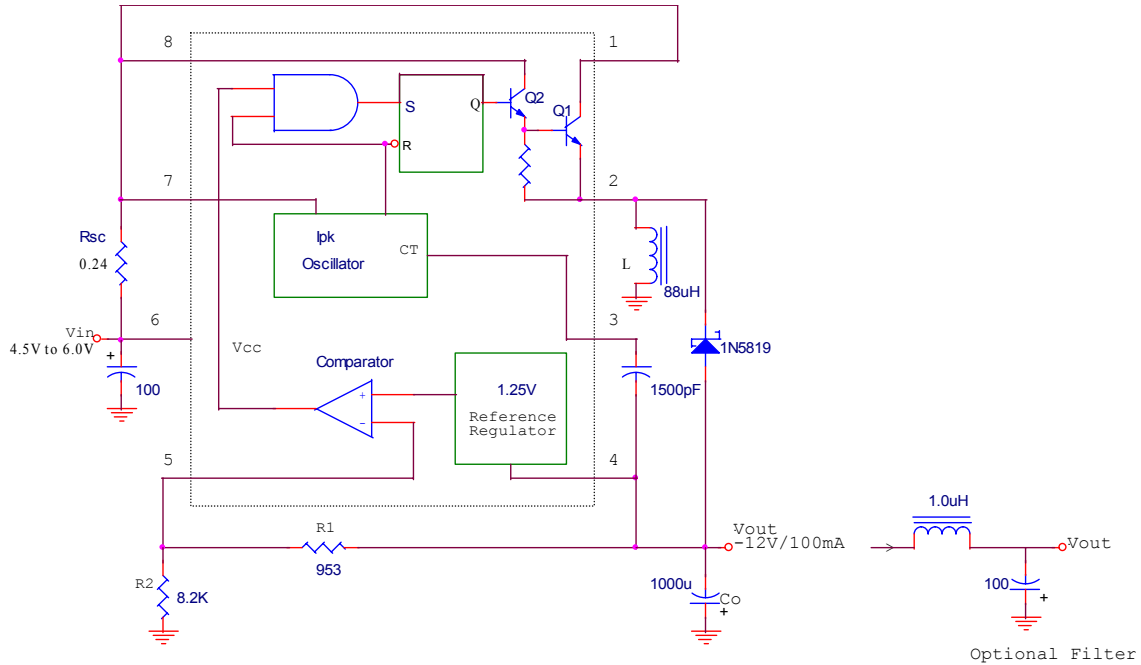

Test	Conditions	Results
Line Regulation	V _{in} =4.5 V to 6.0V, I _O =100 mA	3.0 mV=±0.012%
Load Regulation	V _{in} =5.0 V, I _O =10 mA to 100 mA	0.022 V=±0.09%
Output Ripple	V _{in} =5.0 V, I _O =100 mA	500 mVpp
Short Circuit Current	V _{in} =5.0 V, R _L =0.1 Ω	910 mA
Efficiency	V _{in} =5.0 V, I _O =100 mA	62.2%
Output Ripple With Optional Filter	V _{in} =5.0 V, I _O =100 mA	70 mVpp

Fig 11. Voltage Inverting Converter

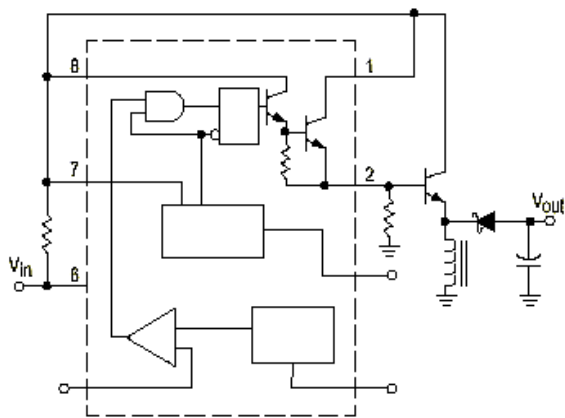

12-1. External NPN Switch

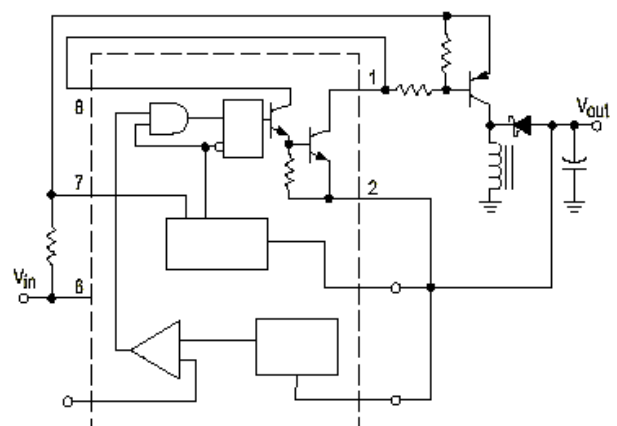

12-2. External PNP Saturated Switch

DC to DC Converter Controller

Fig 12. External Current Boost Connections for I_C Peak Greater than 1.5A

NOTE: 5. If the output switch is driven into hard saturation (non-Darlington configuration) at low switch currents (≤ 300 mA) and high driver currents (≥ 30 mA), it may take up to 2.0 μ s to come out of saturation. This condition will shorten the off time at frequencies ≥ 30 kHz, and is magnified at high temperatures. This condition does not occur with a Darlington configuration, since the output switch cannot saturate. If a non-Darlington configuration is used, the following output drive condition is recommended.

Calculation	Step-Up	Step-Down	Voltage-inverting
t_{on}/t_{off}	$\frac{V_{out} + V_F - V_{in(min)}}{V_{in(min)} - V_{sat}}$	$\frac{V_{out} + V_F}{V_{in(min)} - V_{sat} - V_{out}}$	$\frac{ V_{out} + V_F}{V_{in} - V_{sat}}$
$t_{on}+t_{off}$	$\frac{1}{f}$	$\frac{1}{f}$	$\frac{1}{f}$
t_{off}	$\frac{t_{on} + t_{off}}{\frac{t_{on}}{t_{off}} + 1}$	$\frac{t_{on} + t_{off}}{\frac{t_{on}}{t_{off}} + 1}$	$\frac{t_{on} + t_{off}}{\frac{t_{on}}{t_{off}} + 1}$
t_{on}	$(t_{on}+t_{off})-t_{off}$	$(t_{on}+t_{off})-t_{off}$	$(t_{on}+t_{off})-t_{off}$
C_T	$4.0 \times 10^{-5} t_{on}$	$4.0 \times 10^{-5} t_{on}$	$4.0 \times 10^{-5} t_{on}$
$I_{pk(switch)}$	$2I_{out(max)}(\frac{t_{on}}{t_{off}} + 1)$	$2I_{out(max)}$	$2I_{out(max)}(\frac{t_{on}}{t_{off}} + 1)$
R_{sc}	$0.3/I_{pk(switch)}$	$0.3/I_{pk(switch)}$	$0.3/I_{pk(switch)}$
$L_{(min)}$	$(\frac{(V_{in(min)} - V_{sat})}{I_{pk(switch)}})t_{on(max)}$	$(\frac{(V_{in(min)} - V_{sat} - V_{out})}{I_{pk(switch)}})t_{on(max)}$	$(\frac{(V_{in(min)} - V_{sat})}{I_{pk(switch)}})t_{on(max)}$
C_O	$9 \frac{I_{out} t_{on}}{V_{ripple(pp)}}$	$\frac{I_{pk(switch)}(t_{on} + t_{off})}{8V_{ripple(pp)}}$	$9 \frac{I_{out} t_{on}}{V_{ripple(pp)}}$

Fig 13. Design Formula Table

V_{sat} = Saturation voltage of the output switch.

V_F = Forward voltage drop of the output rectifier.

The following power supply characteristics must be chosen:

V_{in} – Nominal input voltage.

V_{out} – Desired output voltage, $|V_{out}| = 1.25(1 + \frac{R_2}{R_1})$

I_{out} – Desired output current.

f_{min} – Minimum desired output switching frequency at the selected values of V_{in} and I_O .

$V_{ripple(p-p)}$ – Desired peak-to-peak output ripple voltage. In practice, the calculated capacitor value will need to be increased due

to its equivalent series resistance and board layout. The ripple voltage should be kept to a low value since it will directly affect the line and load regulation.