

PRIMARY CHARACTERISTICS	
V_{RRM}	40V,60V,100V,150V,200V
I_O	3.0A
V_F	0.45V,0.55V,0.75V,0.82V,0.85V
$T_{J,Max}$	150°C,175°C

SMA(DO-214AC) PACKAGE

- Body Marking Example
Marking :GA' (5rGA' &&5
Ex :SM' (5

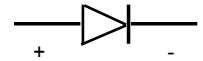
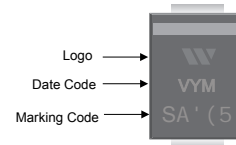

V:Product Lines
Y:A.D. late code, EX : 4-2014,5-2015
M:Month, EX : 1-1,2-2,---10-0,11-N,12-D

FEATURES

- Low Profile surface mount applications in order to optimize board space
- Low power loss, high efficiency
- High current capability, low forward voltage drop
- High surge capability
- Guard ring for overvoltage protection
- Ultra high-speed switching
- Silicon epitaxial planar chip, metal silicon junction
- Moisture Sensitivity Level 1

MECHANICAL DATA

- Case : Molded plastic, SMA(DO-214AC)
- Polarity : Indicated by cathode band
- Terminals :Plated terminals, solderable per MIL-STD-750,Method 2026
- Epoxy : UL94-V0 rated flame retardant

Maximum Ratings and Electrical Characteristics

Ratings at $T_a=25^\circ\text{C}$ unless otherwise noted.
Single phase, half wave, 60Hz, resistive or inductive loaded.
For capacitive load, derate current by 20% .

Parameter	Symbol	SM34A	SM36A	SM310A	SM315A	SM320A	Units
Marking Code		SM34A	SM36A	SM310A	SM315A	SM320A	
Max. Repetitive peak reverse voltage	V_{RRM}	40	60	100	150	200	V
Max. DC blocking voltage	V_{DC}	40	60	100	150	200	V
Max. RMS voltage	V_{RMS}	28	42	70	105	140	V
Max. Instantaneous forward voltage @3.0A, $T_A=25^\circ\text{C}$	V_F	0.45	0.55	0.75	0.82	0.85	V
Operating Temperature	T_J	-50 to +150			-50 to +175		$^\circ\text{C}$

Parameter	Conditions	Symbol	MIN.	TYP.	MAX.	Units
Forward rectified current	see Fig.1	I_O			3.0	A
Forward surge current	8.3ms single half sine-wave superimposed on rate load (JEDEC method)	I_{FSM}			125	A
Reverse Current	$V_R = V_{RRM}$ $T_A=25^\circ\text{C}$	I_R			0.5	mA
	$V_R = V_{RRM}$ $T_A=100^\circ\text{C}$	I_R			20	mA
Thermal Resistance	Junction to ambient	$R_{\theta JA}$		55		$^\circ\text{C/W}$
Diode Junction capacitance	$f=1\text{MHz}$ and applied 4V DC reverse Voltage	C_J		250		pF
Storage temperature		T_{STG}	-50		+175	$^\circ\text{C}$

RATING AND CHARACTERISTIC CURVES (SM34A~SM320A)

Fig.1 - Typical Forward Current Derating Curve

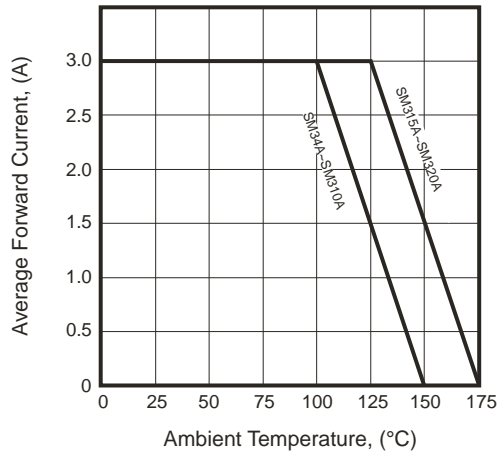

Fig.2 - Typical Forward Characteristics

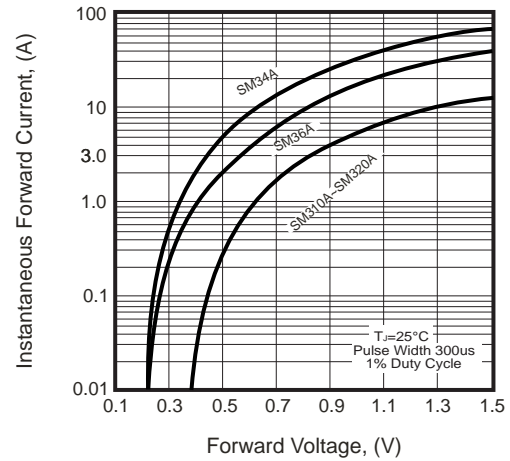

Fig.3 - Maximum Non-repetitive Forward Surge Current

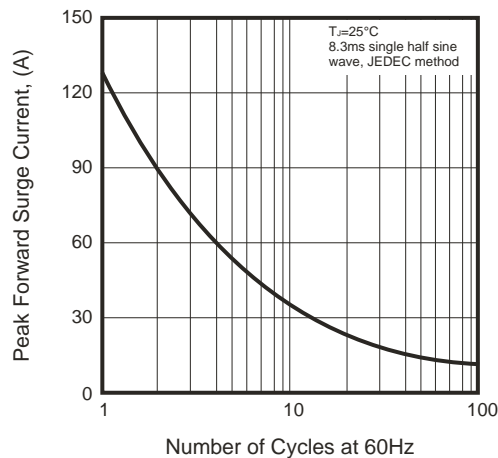

Fig.4 - Typical Junction Capacitance

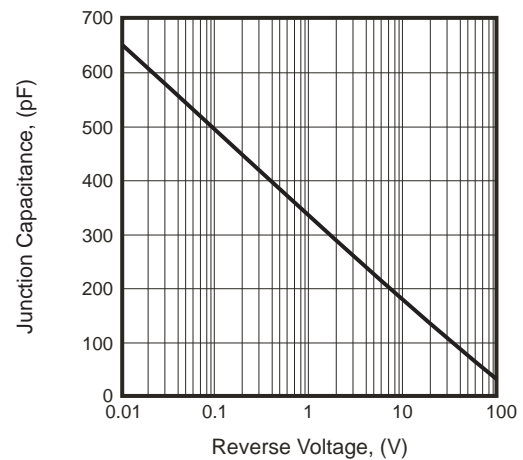
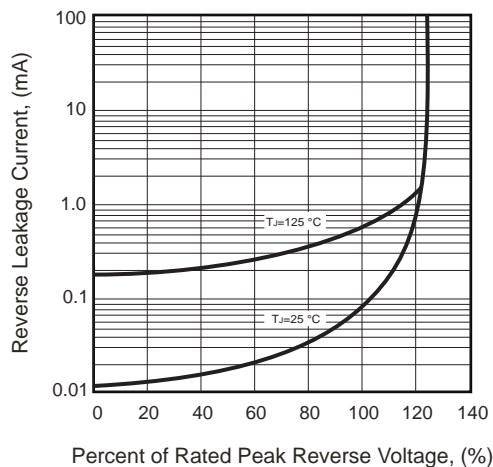
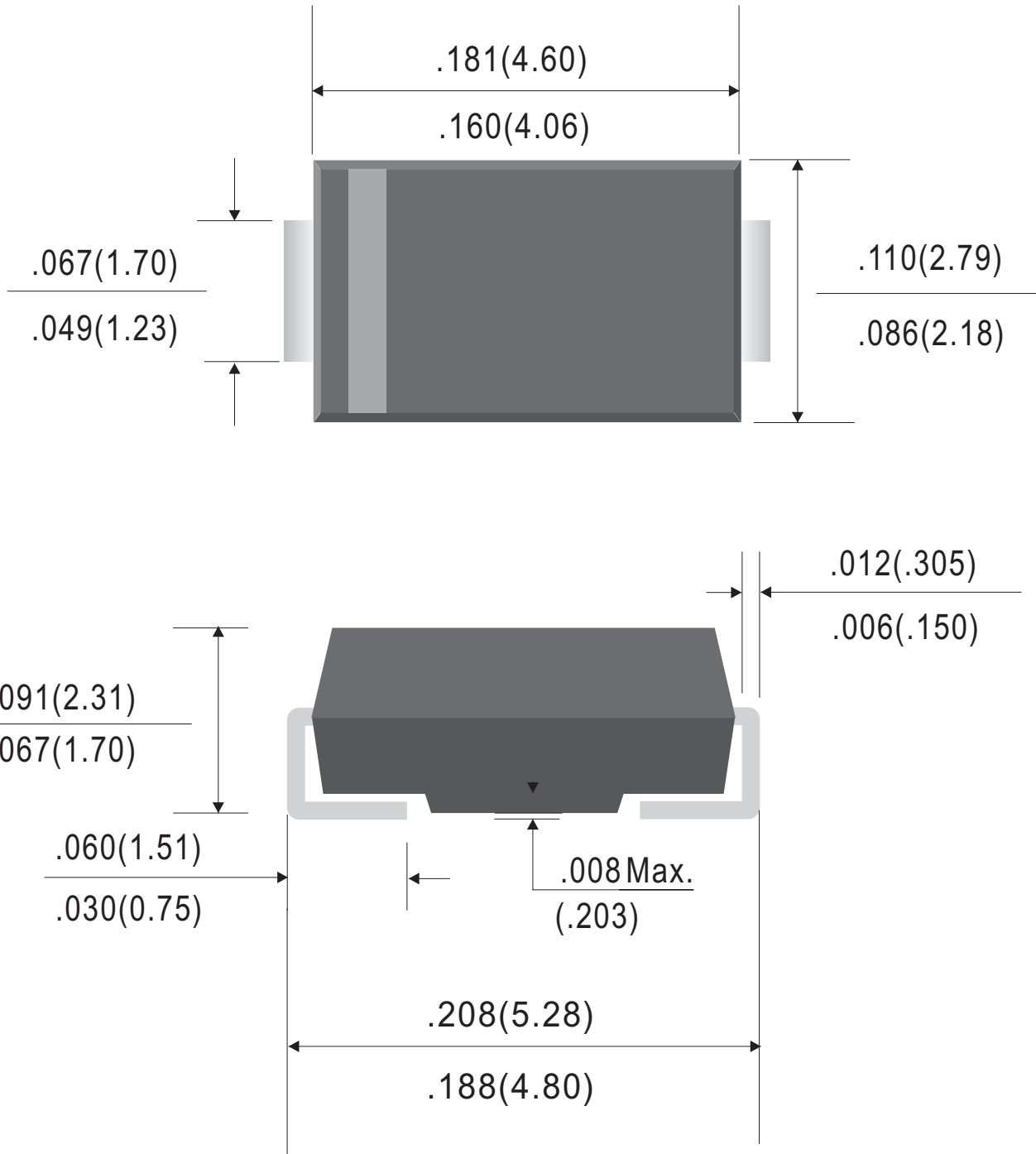

Fig.5 - Typical Reverse Characteristics



Outline Drawing

SMA(DO-214AC)



Dimensions in inches and (millimeters)

Rev.C

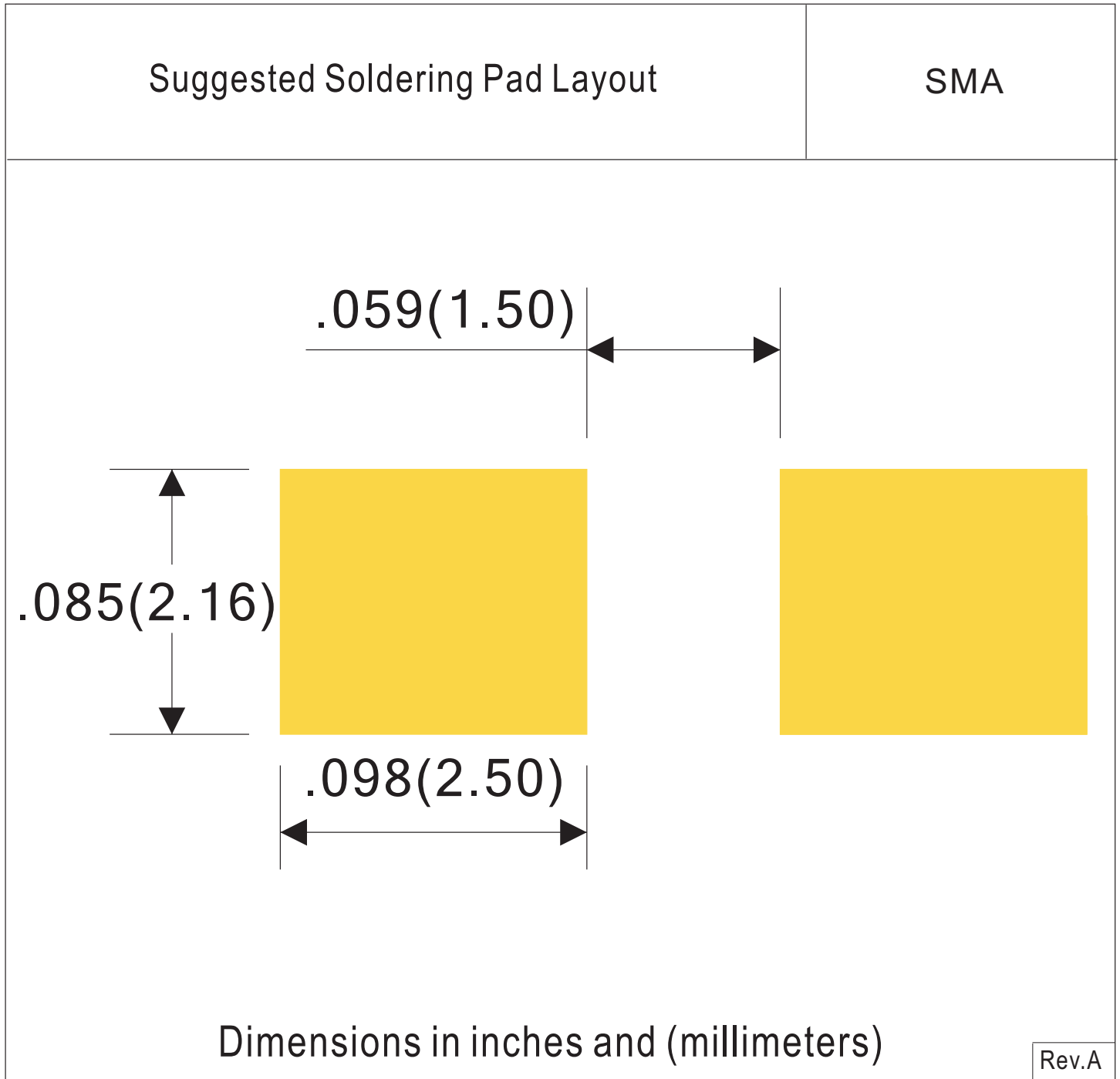

Reel Taping Sepecification - Surface Mount Device

Reel Packing

PACKAGE	PER REEL EA	REEL DIA (m/m)	BOX SIZE (m/m)	PER BOX EA	CARTION (m/m)	PER CARTION EA	GROSS WEIGHT (Kg)
SMA	5,000	330	340*340*40	10,000	355*360*350	80,000	15.0
SMB	3,000	330	340*340*40	6,000	355*360*350	48,000	13.6
SMC	3,000	330	340*340*40	6,000	355*360*350	48,000	18.5

Note. Packing tape color : It's contains colorless & Black.

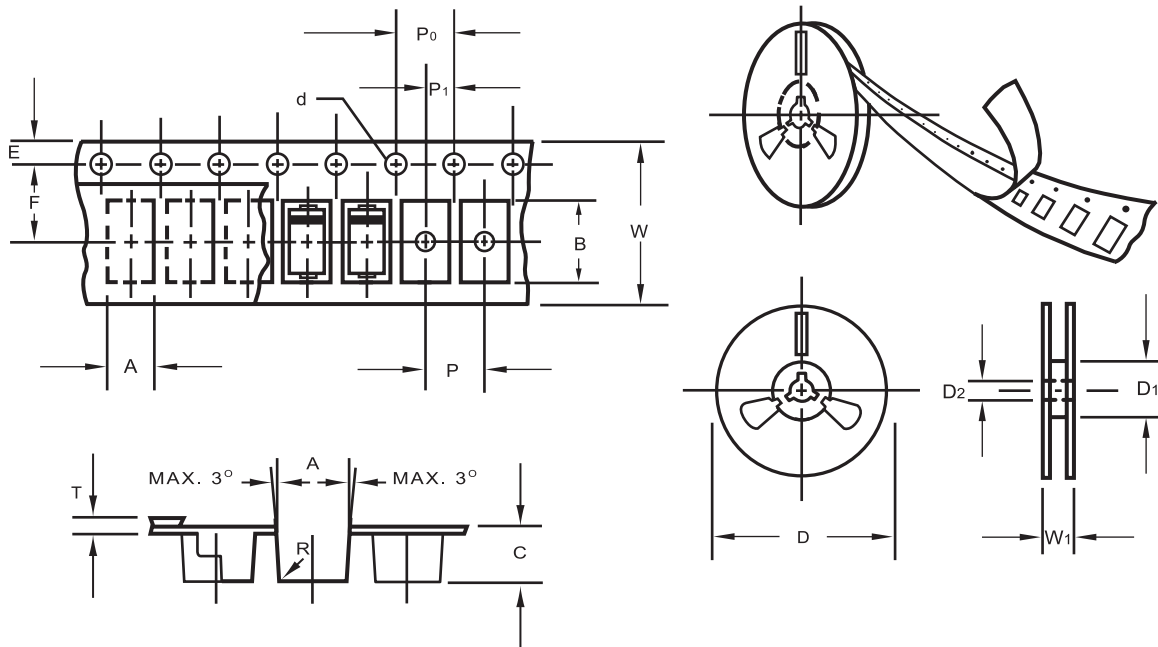

ITEM	SYMBOL	DO214AC (SMA) mm(inch)	DO214AA (SMB) mm(inch)	DO214AB (SMC) mm(inch)
Carrier width	A	3.0 ± 0.1 (.122 ± .004)	3.65 ± 0.1 (.148 ± .004)	6.0 ± 0.1 (.240 ± .004)
Carrier length	B	5.4 ± 0.1 (.213 ± .004)	5.69 ± 0.1 (.224 ± .004)	8.30 ± 0.1 (.330 ± .004)
Carrier depth	C	2.4 ± 0.1 (.098 ± .004)	2.67 ± 0.1 (.105 ± .004)	2.5 ± 0.1 (.100 ± .004)
Sprocket hole	d	1.5 ± 0.1 (.059 ± .004)	1.5 ± 0.1 (.059 ± .004)	1.5 ± 0.1 (.059 ± .004)
Reel outside diameter	D	178 ± 2.0 (7.0 ± 0.79)	178 ± 2.0 (7.0 ± 0.79)	178 ± 2.0 (7.0 ± 0.79)
Reel inner diameter	D1	8.0 ± 0.2 (3.15 ± .008)	8.0 ± 0.2 (3.15 ± .008)	8.0 ± 0.2 (3.15 ± .008)
Feed hole diameter	D2	13 ± 0.5 (.152 ± .020)	13 ± 0.5 (.152 ± .020)	13 ± 0.5 (.152 ± .020)
Stroctet hole position	E	1.5 ± 0.1 (.059 ± .004)	1.5 ± 0.1 (.059 ± .004)	1.5 ± 0.1 (.059 ± .004)
Punch hole position	F	5.65 ± 0.05 (.222 ± .002)	5.65 ± 0.05 (.222 ± .002)	7.65 ± 0.05 (.301 ± .002)
Punch hole pitch	P	4.0 ± 0.1 (.157 ± .004)	8.0 ± 0.1 (.315 ± .004)	8.0 ± 0.1 (.315 ± .004)
Sprocket hole pitch	P0	4.0 ± 0.1 (.157 ± .004)	4.0 ± 0.1 (.157 ± .004)	4.0 ± 0.1 (.157 ± .004)
Embossment center	P1	2.0 ± 0.1 (.79 ± .004)	2.0 ± 0.1 (.79 ± .004)	4.0 ± 0.1 (.157 ± .004)
Totall tape thickness	T	0.30 ± .05 (.012 ± .002)	0.6 MAX.	0.6 MAX.
Tape width	W	12.0 ± 0.2 (.472 ± .008)	12.0 ± 0.2 (.472 ± .008)	16.0 ± 0.2 (.630 ± .008)
Reel with	W1	16.8 ± 2.0 (.661 ± .079)	16.8 ± 2.0 (.661 ± .079)	24.0 ± 2.0 (.945 ± .079)

NOTE: Devices are packed in accordance with EIA standard RS-481-A and specification given above.

Ordering Information:

Device PN	Packing
Part Number -T ⁽¹⁾ G ⁽²⁾ -WS	Tape&Reel: K pcs/Reel

Note: (1) Packing code, Tape & Reel Packing

(2) RoHS product for packing code suffix "G" ; Halogen free product for packing code suffix "H"

Disclaimer

WILLAS reserves the right to make changes without notice to any product specification herein, to make corrections, modifications, enhancements or other changes. WILLAS or anyone on its behalf assumes no responsibility or liability for any errors or inaccuracies. Data sheet specifications and its information contained are intended to provide a product description only. "Typical" parameters which may be included on WILLAS data sheets and/ or specifications can and do vary in different applications and actual performance may vary over time. WILLAS does not assume any liability arising out of the application or use of any product or circuit.

This is the preliminary specification. WILLAS products are not designed, intended or authorized for use in medical, life-saving implant or other applications intended for life-sustaining or other related applications where a failure or malfunction of component or circuitry may directly or indirectly cause injury or threaten a life without expressed written approval of WILLAS. Customers using or selling WILLAS components for use in such applications do so at their own risk and shall agree to fully indemnify WILLAS Inc and its subsidiaries harmless against all claims, damages and expenditures.