

OVERVIEW

The SM5829P is a variable-length shift register fabricated in Molybdenum-gate CMOS. The length can be set to any value between 2 and 129.

The SM5829P features a maximum operating frequency of 25.0 MHz (2 to 65 steps) and 33.3 MHz (66 to 129 steps), and static registers for data retention during periods when the shift clock is halted, making it ideal for digital video processing and similar applications.

FEATURES

- 2- to 129-step selectable length
- 8-bit (1-byte) parallel input/output
- Uses static registers
- 33.3 MHz (max) operating frequency (66 to 129 steps) and 25.0 MHz (max) operating frequency (2 to 65 steps)
- Shift rotate/non-rotate select function
- Data reset function
- TTL-compatible input/outputs
- 5 ±0.25 V power supply
- 30-pin shrink DIP
- Molybdenum-gate CMOS process

PINOUT

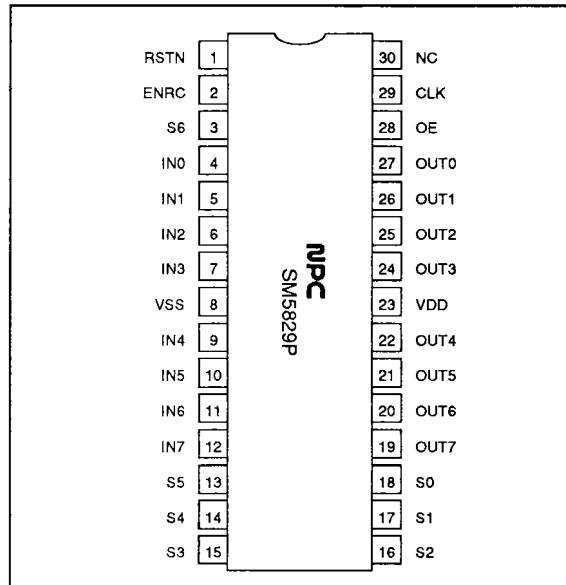

PACKAGE DIMENSIONS

Unit: mm

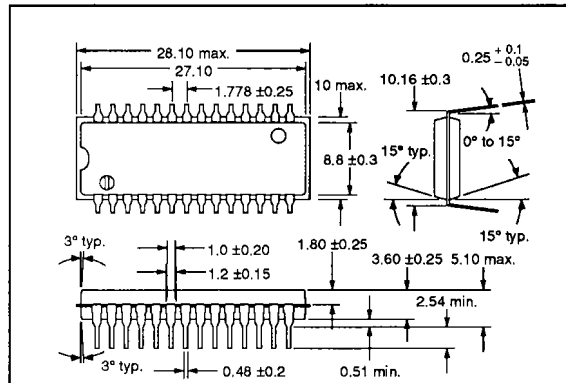

BLOCK DIAGRAM

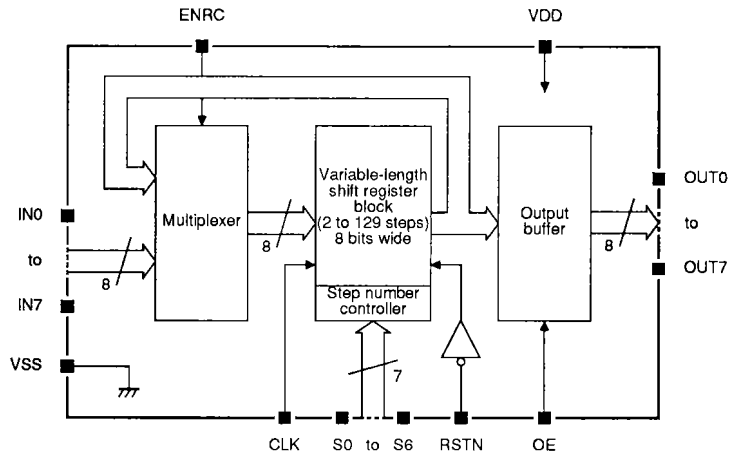

PIN DESCRIPTION

Number	Name	I/O	Description
1	RSTN	I	Data reset
2	ENRC	I	Data rotation control
3	S6	I	Register step select bit 6 (MSB)
4	IN0	I	Data input bit 0 (LSB)
5	IN1	I	Data input bit 1
6	IN2	I	Data input bit 2
7	IN3	I	Data input bit 3
8	VSS		Ground (0 V)
9	IN4	I	Data input bit 4
10	IN5	I	Data input bit 5
11	IN6	I	Data input bit 6
12	IN7	I	Data input bit 7
13	S5	I	Register step select bit 5
14	S4	I	Register step select bit 4
15	S3	I	Register step select bit 3
16	S2	I	Register step select bit 2
17	S1	I	Register step select bit 1
18	S0	I	Register step select bit 0 (LSB)
19	OUT7	O	Data output bit 7
20	OUT6	O	Data output bit 6
21	OUT5	O	Data output bit 5
22	OUT4	O	Data output bit 4
23	VDD		5 V (typ) supply
24	OUT3	O	Data output bit 3

SM5829P

Number	Name	I/O	Description
25	OUT2	O	Data output bit 2
26	OUT1	O	Data output bit 1
27	OUT0	O	Data output bit 0 (LSB)
28	OE	I	Output enable
29	CLK	I	Clock input
30	NC		No connection

SPECIFICATIONS

Absolute Maximum Ratings

$V_{SS} = 0 \text{ V}$

Parameter	Symbol	Rating	Unit
Supply voltage range	V_{DD}	-0.3 to 7.0	V
Input voltage range	V_{IN}	-0.3 to $V_{DD} + 0.3$	V
Power dissipation	P_D	750	mW
Storage temperature range	T_{slg}	-40 to 125	deg. C
Soldering temperature	T_{sld}	255	deg. C
Soldering time	t_{sld}	10	s

Recommended Operating Conditions

$V_{SS} = 0 \text{ V}$

Parameter	Symbol	Rating	Unit
Supply voltage	V_{DD}	4.75 to 5.25	V
Operating temperature range	T_{opr}	-20 to 70	deg. C

DC Electrical Characteristics

$T_a = -20 \text{ to } 70 \text{ deg. C}$, $V_{DD} = 4.75 \text{ to } 5.25 \text{ V}$, $V_{SS} = 0 \text{ V}$ unless otherwise noted

Parameter	Symbol	Condition	Rating			Unit
			min	typ	max	
Standby supply current	I_{ST}	$V_{DD} = 5.25 \text{ V}$	-	1	100	μA
Operating current consumption	I_{DD}	$f_{CLK} = 33.3 \text{ MHz}$, $V_{IH} = 2.4 \text{ V}$, $V_{IL} = 0.5 \text{ V}$, $V_{OE} = 0 \text{ V}$, $V_{DD} = 5 \text{ V}$	-	-	110	mA
IN0 to IN7, S0 to S6, ENRC, CLK, RSTN and OE HIGH-level input voltage	V_{IH}	See note 1.	2.4	-	-	V
IN0 to IN7, S0 to S6, ENRC, CLK, RSTN and OE LOW-level input voltage	V_{IL}	See note 1.	-	-	0.5	V
OUT0 to OUT7 HIGH-level output voltage	V_{OH}	$I_{OH} = -0.4 \text{ mA}$. See note 2.	2.5	-	-	V

SM5829P

Parameter	Symbol	Condition	Rating			Unit
			min	typ	max	
OUT0 to OUT7 LOW-level output voltage	V_{OL}	$I_{OL} = 1.6 \text{ mA}$. See note 2.	–	–	0.4	V
IN0 to IN7, S0 to S6, ENRC, CLK, RSTN and OE input current	I_{IL}	$V_{IN} = 0 \text{ V}$. See note 1.	–	10	20	μA
IN0 to IN7, S0 to S6, ENRC, CLK, RSTN and OE input leakage current	I_{LH}	$V_{IN} = V_{DD}$. See note 1.	–	–	1	μA
OUT0 to OUT7 high-impedance output HIGH-level leakage current	I_{ZH}	$V_{OUT} = V_{DD}$. See note 2.	–	–	5	μA
OUT0 to OUT7 high-impedance output LOW-level leakage current	I_{ZL}	$V_{OUT} = 0 \text{ V}$. See note 2.	–	–	5	μA

Notes

1. Pins IN0 to IN7, S0 to S6, ENRC, CLK, RSTN and OE are inputs with internal pull-up resistances.
2. Pins OUT0 to OUT7 are tristate outputs.

AC Electrical Characteristics

$T_a = -20 \text{ to } 70 \text{ deg. C}$, $V_{DD} = 4.75 \text{ to } 5.25 \text{ V}$, $V_{SS} = 0 \text{ V}$ unless otherwise noted

Parameter	Symbol	Condition	Rating			Unit
			min	typ	max	
Clock frequency (2 to 65 steps)	f_{CLK}	$V_{IH} = 2.4 \text{ V}$, $V_{IL} = 0.5 \text{ V}$	–	–	25.0	MHz
Clock frequency (66 to 129 steps)			–	–	33.3	
Clock rise time	t_{cr}		–	–	100	ns
Clock fall time	t_{cf}		–	–	100	ns
Clock HIGH-level pulsewidth	t_{WH}		13	–	–	ns
Clock LOW-level pulsewidth	t_{WL}		13	–	–	ns
IN0 to IN7 input setup time	t_{S1}		13	–	–	ns
S0 to S6 input setup time	t_{S2}		50	–	–	ns
ENRC input setup time	t_{S3}		20	–	–	ns
IN0 to IN7 and ENRC input hold time	t_{H1}		0	–	–	ns
S0 to S6 input hold time	t_{H2}		5	–	–	ns
OE to OUT $_n$ output enable delay time	$t_{OEN0, 1}$	See note 4.	–	–	25	ns
OE to OUT $_n$ output disable delay time	$t_{ODE0, 1}$	See note 4.	–	–	25	ns
CLK to OUT $_n$ output data hold time	t_{OH1}	See note 3.	10	–	–	ns
RSTN to OUT $_n$ output data hold time	t_{OH2}	See note 3.	10	–	–	ns
CLK to OUT $_n$ output data propagation delay time	t_{PD1}	See note 3.	–	–	28	ns
RSTN to OUT $_n$ output data propagation delay time	t_{PD2}	See note 3.	–	–	28	ns

SM5829P

Parameter	Symbol	Condition	Rating			Unit
			min	typ	max	
IN0 to IN7, S0 to S6, ENRC, CLK, RSTN and OE input capacitance	C_{IN}	$f = 1 \text{ MHz}$	-	-	10	pF
OUT0 to OUT7 output capacitance	C_{OUT}	$f = 1 \text{ MHz}, V_{OE} = 0 \text{ V}$	-	-	20	pF

Notes

1. Pins IN0 to IN7, S0 to S6, ENRC, CLK, RSTN and OE are inputs with internal pull-up resistances.
2. Pins OUT0 to OUT7 are tristate outputs.
3. Measurement circuit 1

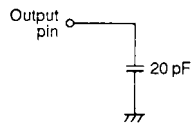

4. Measurement circuit 2

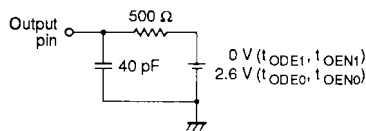

Timing Diagrams

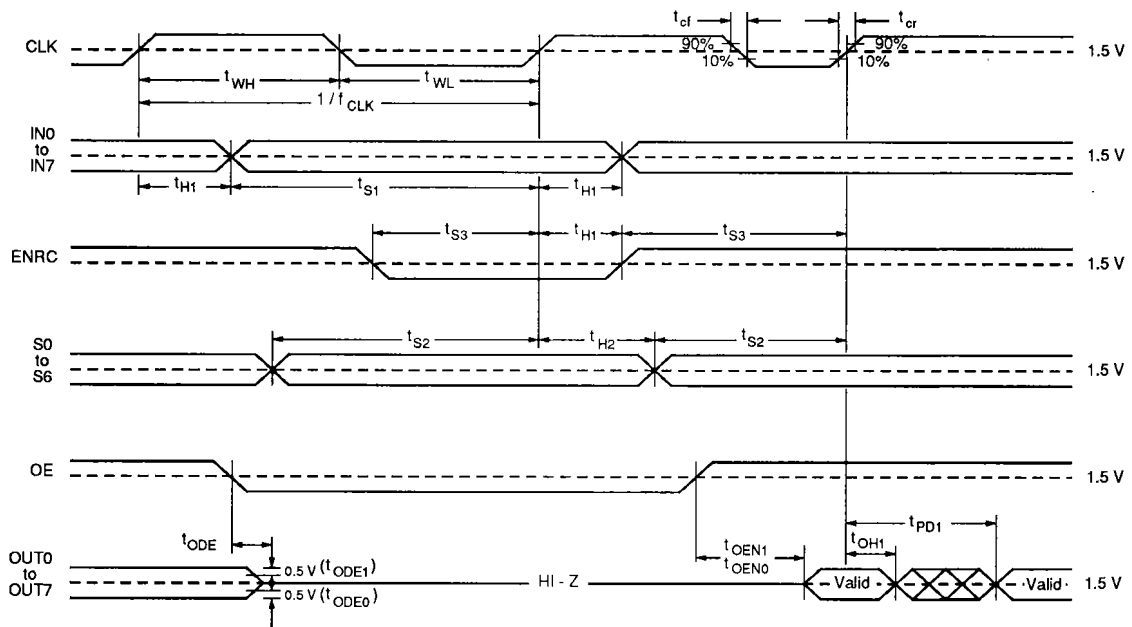

SM5829P

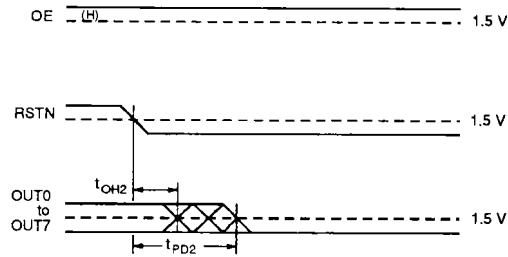

Typical Performance Characteristics

Typical values at $V_{DD} = 5.0\text{ V}$

Maximum clock frequency vs. ambient temperature

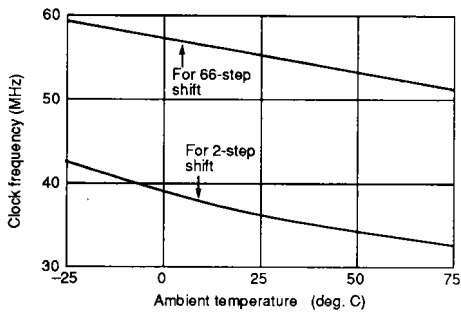

Output delay time vs. ambient temperature

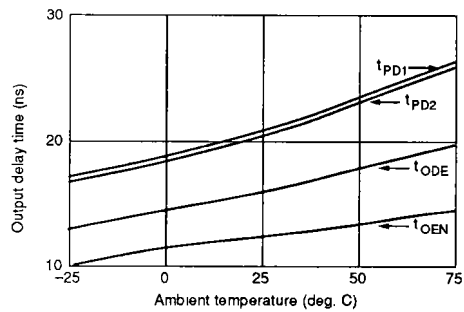

Operating supply current vs. clock frequency

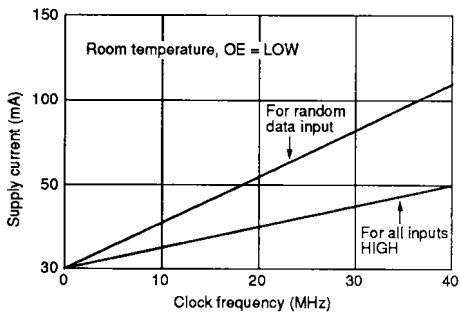

Minimum setup time vs. ambient temperature 1

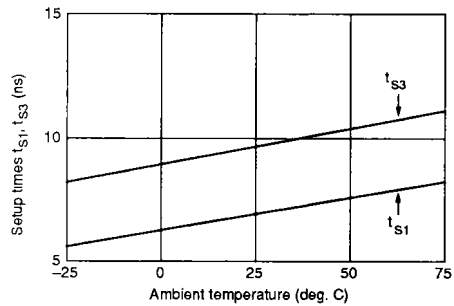

Minimum setup time vs. ambient temperature 2

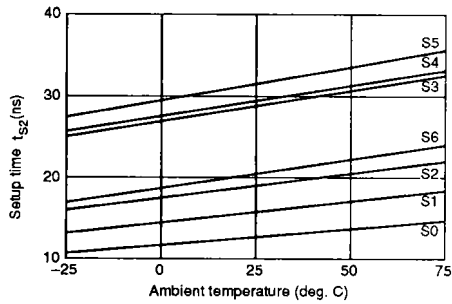

2. t_{s2} varies with the length of the shift register. All values are measured under worst conditions.
 - a. All step select inputs are LOW except the one being measured.
 - b. The value of t_{s2} of the measured step select input may be less than the value shown if any other step select input is HIGH, except for S0 which is not affected by other step select inputs.

Notes

1. t_{s1} and t_{s3} do not vary with the length of the shift register.

FUNCTIONAL DESCRIPTION

Register Step Selection

Register operation

The internal structure of the shift register is shown in the following figure. Inputs S0 to S6 select or bypass the outputs of their corresponding shift register blocks. Combinations of S0 to S6 thus

select the shift register length of between 2 and 129. Note that the first and last registers are always enabled.

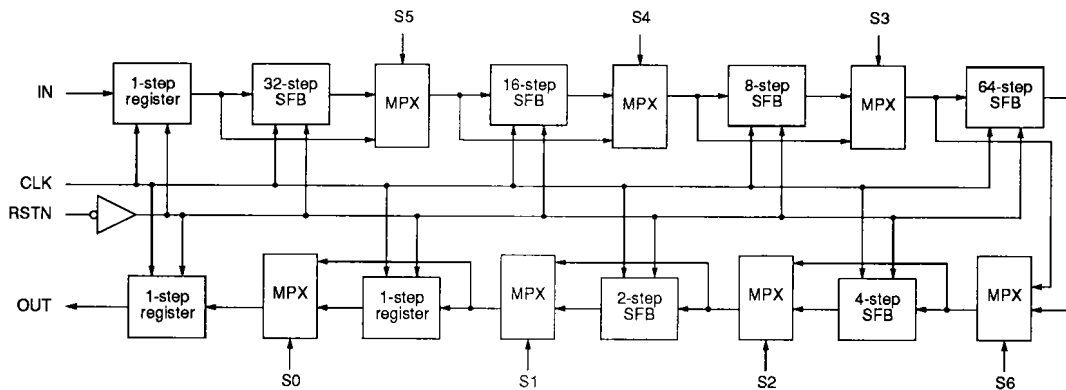

Register length select

The S0 to S6 inputs select the register length. The length is given by the decimal value (S6 is MSB) plus 2.

$$\text{Length} = 64 \cdot (S6) + 32 \cdot (S5) + 16 \cdot (S4) + 8 \cdot (S3) + 4 \cdot (S2) + 2 \cdot (S1) + (S0) + 2$$

Step number	S6	S5	S4	S3	S2	S1	S0
129	HIGH	HIGH	HIGH	HIGH	HIGH	HIGH	HIGH
128	HIGH	HIGH	HIGH	HIGH	HIGH	HIGH	LOW
127	HIGH	HIGH	HIGH	HIGH	HIGH	LOW	HIGH
126	HIGH	HIGH	HIGH	HIGH	HIGH	LOW	LOW

SM5829P

Step number	S6	S5	S4	S3	S2	S1	S0
⋮	⋮	⋮	⋮	⋮	⋮	⋮	⋮
67	HIGH	LOW	LOW	LOW	LOW	LOW	HIGH
66	HIGH	LOW	LOW	LOW	LOW	LOW	LOW
65	LOW	HIGH	HIGH	HIGH	HIGH	HIGH	HIGH
⋮	⋮	⋮	⋮	⋮	⋮	⋮	⋮
4	LOW	LOW	LOW	LOW	LOW	HIGH	LOW
3	LOW	LOW	LOW	LOW	LOW	LOW	HIGH
2	LOW	LOW	LOW	LOW	LOW	LOW	LOW

Note

Pins S0 to S6 have internal pull-up resistances. Therefore, only LOW-level pins need be tied to ground. However, it is recommended that HIGH-level inputs be tied to VDD for applications using fixed-length shifting.

Input/Output Control

Inputs				Shift register (internal)	Outputs
RSTN	ENRC	CLK	OE		OUT0 to OUT7
×	×	×	LOW		High impedance
×	×	×	HIGH		Enable
HIGH	HIGH	LOW-to-HIGH	×	Rotate shift	
HIGH	LOW	LOW-to-HIGH	×	Non-rotate shift	
LOW	×	×	×	Reset	

Note

× = don't care

NIPPON PRECISION CIRCUITS LTD. reserves the right to make changes to the products contained in this data sheet in order to improve the design or performance and to supply the best possible products. Nippon Precision Circuits Ltd. assumes no responsibility for the use of any circuits shown in this data sheet, conveys no license under any patent or other rights, and makes no claim that the circuits are free from patent infringement. Applications for any devices shown in this data sheet are for illustration only and Nippon Precision Circuits Ltd. makes no claim or warranty that such applications will be suitable for the use specified without further testing or modification.

 NPC NIPPON PRECISION CIRCUITS LTD.	NIPPON PRECISION CIRCUITS LTD. Shuwa Sakurabashi Building 5-4, Hachobori 4-chome Chuo-ku, Tokyo 104 Japan Telephone: 03-3555-7521 Facsimile: 03-3555-7528
---	---

NC9108AE 1993.08