

## OVERVIEW

The SM5866AS is a D/A converter compatible with both the DSD SACD signal format and the PCM CD/DVD-Audio and similar formats. DSD employs a 1-bit data stream, from a high-order  $\Delta\Sigma$  conversion at 64fs ( $f_s = 44.1\text{kHz}$ ), that contains high-level quantization noise in the high-frequency band above 20kHz. The SM5866AS, in DSD reproduction, has a DSD-dedicated FIR digital filter that attenuates the

DSD quantization noise in the digital domain, and the resulting multi-level signal is D/A converted. In PCM reproduction, an oversampled PCM signal input, provided using a SM5847AF or similar digital filter, is converted to a multi-level signal by the 3rd-order noise shaper and then the multi-level signal is D/A converted.

## FEATURES

- Mono-channel multi-level D/A converter
- High performance analog characteristics
  - DSD mode (typical values)
    - THD + N:  $-109\text{dB}$  (0.00036%)
    - D.R: 115dB
  - PCM mode (typical values)
    - THD+N:  $-106\text{dB}$  (0.00050%)
    - D.R: 112dB
- 2 selectable DSD digital filters
- PCM input mode
  - 24-bit, MSB-first, right-justified
  - 8-times or 4-times oversampling of  $f_s = 16\text{k}$  to 192kHz
- System clock (CKI)
  - Maximum operating frequency:  $f_{\text{CKI}}$  (max)
    - 37.0MHz (note 1)
    - 45.4MHz (note 2)
- DSD mode  $f_s = f_{\text{CKI}}/512$ 
  - typ.  $f_s = 44.1\text{kHz}$
  - max.  $f_s = 52.7\text{kHz}$  (note 1)
  - max.  $f_s = 88.7\text{kHz}$  (note 2)
- PCM mode system clock
  - 192/256/384/512/768fs
- Operating voltage: 4.5 to 5.5V
- Operating temperature:  $-40$  to  $85^\circ\text{C}$
- Package: 28-pin SOP
- Molybdenum-gate CMOS process

(note 1) Under the operating conditions 1: 4.5 to 5.5V,  $-40$  to  $85^\circ\text{C}$   
(note 2) Under the operating conditions 2: 4.75 to 5.25V,  $-40$  to  $70^\circ\text{C}$

## ORDERING INFORMATION

Device	Package
SM5866AS	28-pin SOP

## PINOUT

(Top view)

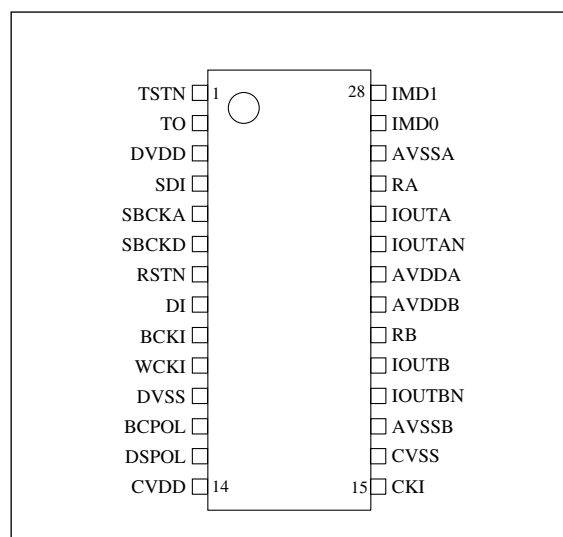

## PACKAGE DIMENSIONS

(Unit: mm)

Weight: 0.60g

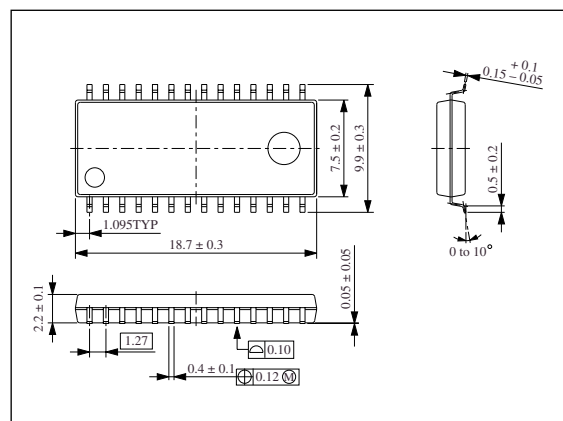

**BLOCK DIAGRAM**

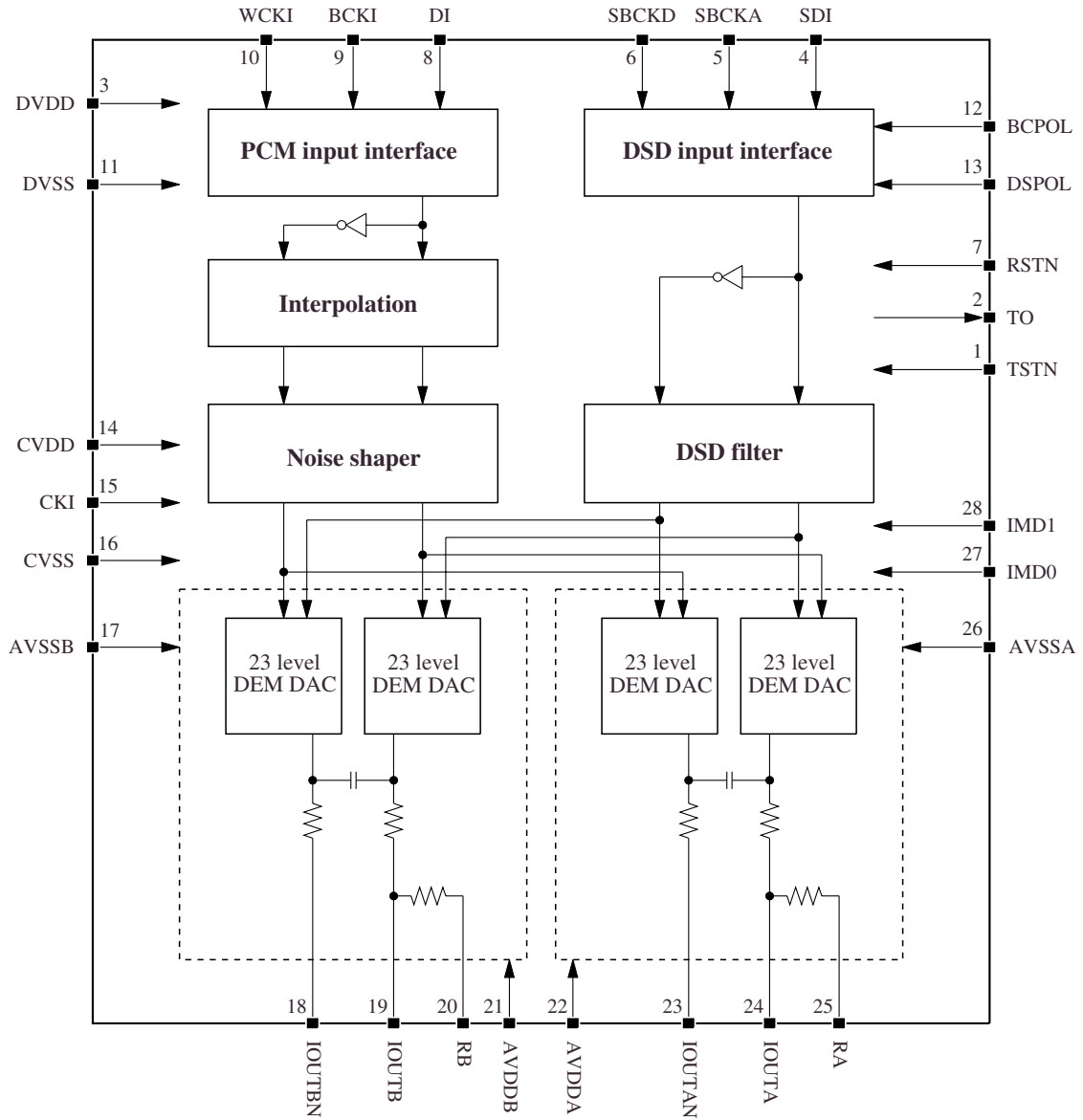

## PIN DESCRIPTION

Number	Name	I/O <sup>1</sup>	Description
1	TSTN	Ip	Test mode use only (tie HIGH or leave open for normal operation)
2	TO	O	Test mode use only (leave open for normal operation)
3	DVDD	–	Digital supply VDD
4	SDI	Ip	DSD data input
5	SBCKA	Ip	DSD bit clock input
6	SBCKD	Ip	DSD bit clock input (tie LOW for DSD normal input mode)
7	RSTN	Ip	System reset (active LOW)
8	DI	Ip	PCM data input
9	BCKI	Ip	PCM bit clock input
10	WCKI	Ip	PCM word clock input
11	DVSS	–	Digital ground VSS
12	BCPOL	Ip	DSD mode bit clock polarity select
13	DSPOL	Ip	DSD mode data polarity select
14	CVDD	–	System clock supply VDD
15	CKI	I	System clock
16	CVSS	–	System clock ground VSS
17	AVSSB	–	B-channel analog ground VSS
18	IOUTBN	O	B-channel analog output (inverse-phase)
19	IOUTB	O	B-channel analog output (in-phase)
20	RB	I	B-channel built-in resistor connection
21	AVDDB	–	B-channel analog supply VDD
22	AVDDA	–	A-channel analog supply VDD
23	IOUTAN	O	A-channel analog output (inverse-phase)
24	IOUTA	O	A-channel analog output (in-phase)
25	RA	I	A-channel built-in resistor connection
26	AVSSA	–	A-channel analog ground VSS
27	IMD0	Ip	Input mode select
28	IMD1	Ip	Input mode select

1. Ip = input pin with built-in pull-up resistor

## SPECIFICATIONS

### Absolute Maximum Ratings

DVSS = CVSS = AVSSA = AVSSB = 0 V, DVDD = CVDD = AVDDA = AVDDB

Parameter	Symbol	Rating	Unit
Supply voltage range	DVDD, CVDD, AVDDA, AVDDB	-0.3 to 7.0	V
Input voltage range <sup>1</sup>	V <sub>IN1</sub>	DVSS - 0.3 to DVDD + 0.3	V
Storage temperature range	T <sub>STG</sub>	-55 to 125	°C
Power dissipation	P <sub>D</sub>	250	mW

1. Pins TSTN, SDI, SBCKA, SBCKD, RSTN, DI, BCKI, WCKI, BCPOL, DSPOL, IMD0, IMD1.

Note: Rating applies at power-ON and power-OFF.

### Recommended Operating Conditions

DVSS = CVSS = AVSSA = AVSSB = 0 V, DVDD = CVDD = AVDDA = AVDDB

Parameter	Symbol	Rating	Unit
Supply voltage range	DVDD, CVDD, AVDDA, AVDDB	4.5 to 5.5	V
Supply voltage differential	DVDD - CVDD, DVDD - AVDDA, DVDD - AVDDB, CVDD - AVDDA, CVDD - AVDDB, AVDDA - AVDDB, DVSS - CVSS, DVSS - AVSSA, DVSS - AVSSB, CVSS - AVSSA, CVSS - AVSSB, AVSSA - AVSSB	±0.1	V
Operating temperature range	T <sub>OPR</sub>	-40 to 85	°C

Note: DVDD, CVDD, AVDDA, AVDDB are connected on the LSI substrate, and so the same potential should be applied to these inputs.

### DC Electrical Characteristics

Recommended operating conditions apply unless otherwise noted.

Parameter	Symbol	Condition	Rating			Unit
			min	typ	max	
DVDD, CVDD, AVDDA, AVDDB current consumption <sup>1</sup>	I <sub>DD</sub>	f <sub>CKI</sub> = 22.5792 MHz	-	13	18	mA
		f <sub>CKI</sub> = 45.1584 MHz	-	25	32	mA
CKI HIGH-level input voltage	V <sub>IHC</sub>		0.7 × DVDD	-	-	V
CKI LOW-level input voltage	V <sub>ILC</sub>		-	-	0.3 × DVDD	V
CKI input voltage	V <sub>INAC</sub>	AC coupling	1.0	-	-	V <sub>p-p</sub>
HIGH-level input voltage <sup>2</sup>	V <sub>IH</sub>		2.4	-	-	V
LOW-level input voltage <sup>2</sup>	V <sub>IL</sub>		-	-	0.5	V
HIGH-level output voltage <sup>3</sup>	V <sub>OH</sub>	I <sub>OH</sub> = -1 mA	DVDD - 0.4	-	-	V
LOW-level output voltage <sup>3</sup>	V <sub>OL</sub>	I <sub>OL</sub> = 1 mA	-	-	0.4	V
CKI HIGH-level input current	I <sub>IHC</sub>	V <sub>IN</sub> = DVDD	20	60	120	μA
CKI LOW-level input current	I <sub>ILC</sub>	V <sub>IN</sub> = 0 V	20	60	120	μA
LOW-level input current <sup>2</sup>	I <sub>IL1</sub>	V <sub>IN</sub> = 0 V	-	9	18	μA
HIGH-level input leakage current <sup>2</sup>	I <sub>IH1</sub>	V <sub>IN</sub> = DVDD	-	-	1.0	μA

1. all outputs have no load. Input data is an NPC test pattern.

2. Pins TSTN, SDI, SBCKA, SBCKD, RSTN, DI, BCKI, WCKI, BCPOL, DSPOL, IMD0, IMD1.

3. Pin TO.

## Switching Characteristics

### System clock (CKI)

Operating conditions 1:  $V_{DD} = 4.5$  to  $5.5V$ ,  $T_{OPR} = -40$  to  $85^{\circ}C$

Parameter	Symbol	Rating			Unit
		min	typ	max	
HIGH-level clock pulsewidth	$t_{CWH}$	7	–	100	ns
LOW-level clock pulsewidth	$t_{CWL}$	7	–	100	ns
Clock pulse cycle	$t_{CKI}$	27	–	200	ns

Operating conditions 2:  $V_{DD} = 4.75$  to  $5.25V$ ,  $T_{OPR} = -40$  to  $70^{\circ}C$

Parameter	Symbol	Rating			Unit
		min	typ	max	
HIGH-level clock pulsewidth	$t_{CWH}$	7	–	100	ns
LOW-level clock pulsewidth	$t_{CWL}$	7	–	100	ns
Clock pulse cycle	$t_{CKI}$	22	–	200	ns

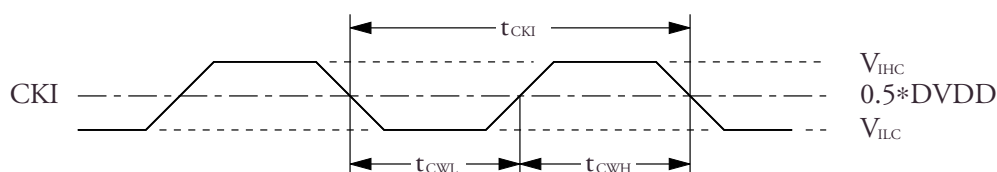

### Reset input (RSTN)

Parameter	Symbol	Conditions	Rating			Unit
			min	typ	max	
RSTN pulsewidth (active LOW)	$t_{RSTN}$	At power-ON	1	–	–	$\mu s$
		After power-ON	100	–	–	ns

**DSD normal input mode (SDI, SBCKA)**

Parameter	Symbol	Rating			Unit
		min	typ	max	
SBCKA frequency	$f_{SBA}$	–	2.8224	–	MHz
SBCKA HIGH-level pulsewidth	$t_{SBAWH}$	40	–	–	ns
SBCKA LOW-level pulsewidth	$t_{SBAWL}$	40	–	–	ns
SDI setup time	$t_{SDS}$	10	–	–	ns
SDI hold time	$t_{SDH}$	10	–	–	ns

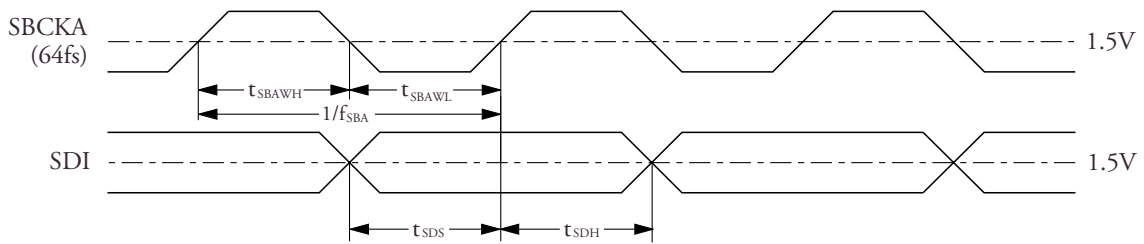

SBCKD = LOW  
 This figure applies when BCPOL = LOW (SBCKA rising edge read-in).  
 When BCPOL = HIGH, SBCKA has opposite phase.

**DSD phase-modulated input mode (SDI, SBCKA, SBCKD)**

Parameter	Symbol	Rating			Unit
		min	typ	max	
SBCKA frequency	$f_{SBA}$	–	5.6448	–	MHz
SBCKA HIGH-level pulsewidth	$t_{SBAWH}$	20	–	–	ns
SBCKA LOW-level pulsewidth	$t_{SBAWL}$	20	–	–	ns
SBCKD frequency	$f_{SBD}$	–	2.8224	–	MHz
SBCKD HIGH-level pulsewidth	$t_{SBDWH}$	40	–	–	ns
SBCKD LOW-level pulsewidth	$t_{SBDWL}$	40	–	–	ns
SDI setup time	$t_{SDS}$	10	–	–	ns
SDI hold time	$t_{SDH}$	10	–	–	ns
SBCKA rising edge → SBCKD falling edge	$t_{SAD}$	–20	–	20	ns

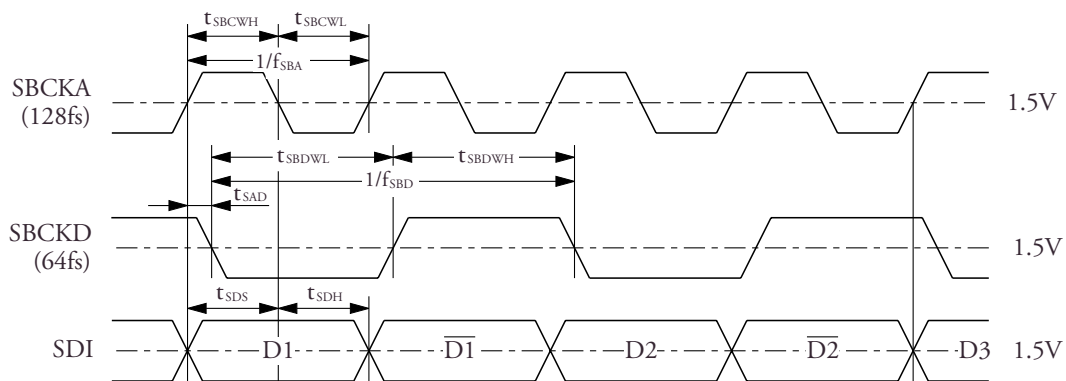

BCPOL = LOW

PCM mode data input (DI, BCKI, WCKI)

Parameter	Symbol	Rating			Unit
		min	typ	max	
BCKI HIGH-level pulsewidth	$t_{BCWH}$	7	-	-	ns
BCKI LOW-level pulsewidth	$t_{BCWL}$	7	-	-	ns
BCKI pulse cycle	$t_{BCY}$	22	-	-	ns
DI setup time	$t_{DS}$	5	-	-	ns
DI hold time	$t_{DH}$	5	-	-	ns
WCKI edge → first BCKI rising edge	$t_{WB}$	10	-	-	ns
Last BCKI rising edge → WCKI edge	$t_{BW}$	10	-	-	ns

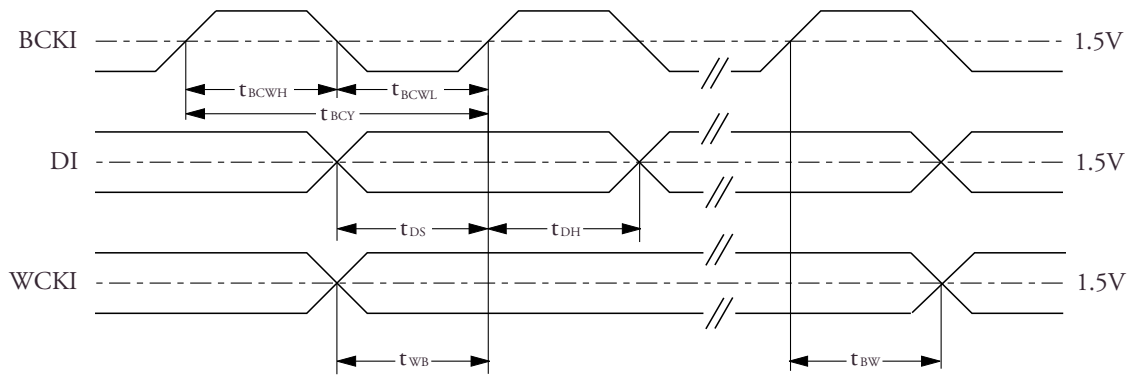

## DSD Mode Analog Characteristics

### Measurement Conditions

Op-amp	:	JRC NJM5534D
Supply voltage	SM5866AS	: DVDD = CVDD = AVDDA = AVDDB = 5V, DVSS = CVSS = AVSSA = AVSSB = 0V
	NJM5534D	: $\pm 15V$
Mode setting	:	H-Mode (uses H-Filter)
Measurement temperature	:	25°C
Input data	:	SUPER AUDIO CD DAC Test Disc (PHILIPS, 3122-783-00632)
System clock	:	22.5792MHz
Measurement equipment	:	Audio Precision System Two (RMS mode)
Filter conditions	:	THD + N    22Hz HPF, 20kHz LPF (FLP-A20K), Unweighted D.R         22Hz HPF, 20kHz LPF (AES17), A-weighted (FIL-AWT) S/N         22Hz HPF, 20kHz LPF (AES17), A-weighted (FIL-AWT)
Measurement circuit	:	Refer to “Measurement circuit”.

### Analog Characteristics

Parameter	Symbol	Conditions	Rating			Unit
			min	typ	max	
LSI output level <sup>1</sup>	$V_{out1}$	1 kHz, 0 dB	0.92	0.97	1.02	Vrms
Evaluation board output level	$V_{out2}$	1 kHz, 0 dB	–	5.7	–	Vrms
Total harmonic distortion	0dB	THD + N 1 kHz, 0 dB	–	–109 (0.00036%)	–105 (0.00056%)	dB
	–20dB		–	–92	–88	dB
	–60dB		–	–52	–48	dB
Dynamic range	D.R	1 kHz, –60 dB	111	115	–	dB
Signal-to-noise ratio	S/N	1 kHz, 0 dB/–∞	112	116	–	dB

1. Input stage I/V op-amp, U101 output level (when R101 = 0Ω)



## PCM Mode Analog Characteristics

### Measurement Conditions

Digital filter	:	NPC SM5847AF
Op-amp	:	JRC NJM5534D
Supply voltage	SM5866AS	: DVDD = CVDD = AVDDA = AVDDB = 5V, DVSS = CVSS = AVSSA = AVSSB = 0V
	SM5847AF	: + 3.3V
	NJM5534D	: ± 15V
Mode settings	:	D-Mode
Measurement temperature	:	25°C
Input data	:	44.1kHz sampling, 24-bit data, no dither
System clock	:	22.5792MHz (512fs), 64fs operation
Measurement equipment	:	Audio Precision System Two (RMS mode)
Filter conditions	:	THD + N    22Hz HPF, 20kHz LPF (FLP-A20K) Unweighted D.R         22Hz HPF, 22kHz LPF, A-weight (FIL-AWT) S/N         22Hz HPF, 22kHz LPF, A-weight (FIL-AWT)
Measurement circuit	:	Refer to “Measurement circuit”.

### Analog Characteristics

Parameter	Symbol	Conditions	Rating			Unit
			min	typ	max	
LSI output level <sup>1</sup>	$V_{out1}$	1 kHz, 0 dB	1.23	1.28	1.33	Vrms
Evaluation board output level	$V_{out2}$	1 kHz, 0 dB	–	5.7	–	Vrms
Total harmonic distortion	THD + N	1 kHz, 0 dB	–	0.0005 (–106dB)	0.0010 (–100dB)	%
Dynamic range	D.R	1 kHz, –60 dB	106	112	–	dB
Signal-to-noise ratio	S/N	1 kHz, 0 dB/–∞	117	120	–	dB

1. Input stage I/V op-amp, U101 output level (when R101 = 0Ω)

Measurement circuit

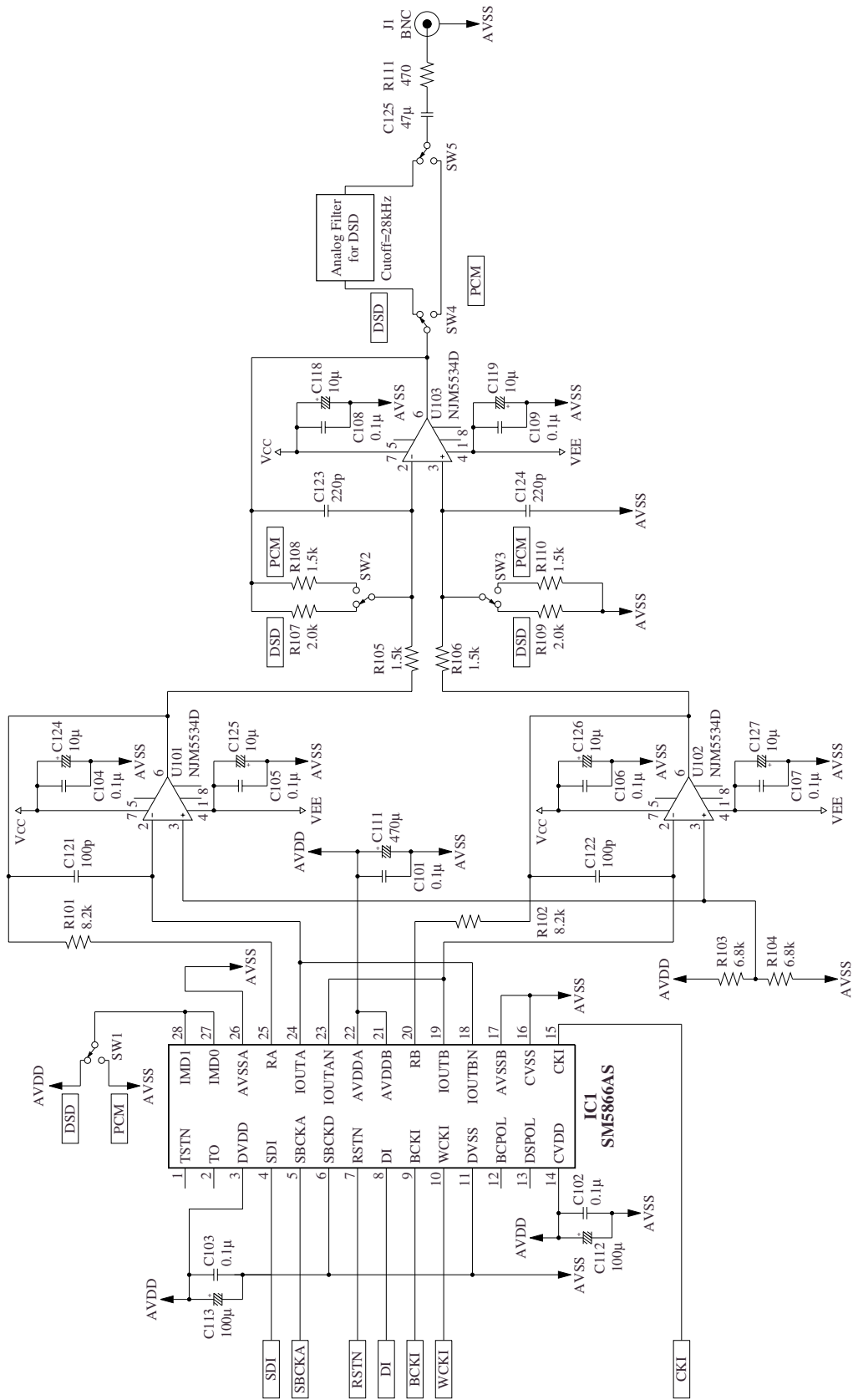

## FUNCTIONAL DESCRIPTION

### Analog Pins

#### Current output pins (IOUTA, IOUTAN, IOUTB, IOUTBN)

The SM5866AS generates current output A differential outputs, formed by input data in-phase signal processed by noise shaper A and then 23-level D/A conversion, and current output B differential outputs, formed by input data inverse-phase signal processed by noise shaper B and then 23-level D/A conversion. A and B differential outputs each have a in-phase output and inverse-phase output: A in-phase output on IOUTA, A inverse-phase output on IOUTAN, B in-phase output on IOUTB, and B inverse-phase output on IOUTBN.

Using external circuits, outputs IOUTA and IOUTAN are added and I/V converted, and IOUTB and IOUTBN are added and I/V converted. Then, the converted signals are input to an op-amp stage to obtain the final output analog signal.

#### Feedback resistor connection pins (RA, RB)

There are internal built-in resistors connected between IOUTA and RA and between IOUTB and RB, which can be used as op-amp feedback resistors. These resistors have a resistance of approximately 6.8k $\Omega$ . An external resistor can be connected to the internal resistor, in serial or parallel, in order to adjust the analog output level. Note, however, that the internal resistance can vary by as much as  $\pm 20\%$  between individual LSI devices, and thus the output level may change with the difference in the ratio of internal resistance to external resistance.

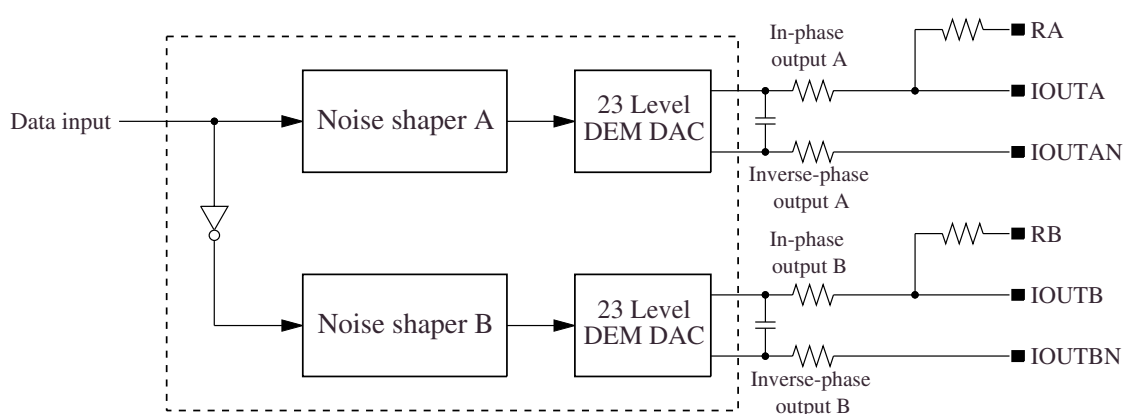

Figure 1. Analog outputs

### Input Mode Settings (IMD0, IMD1)

IMD0 and IMD1 pin settings switch between the DSD and PCM operating modes. In DSD mode, the DSD signal high-frequency components can be removed using one of DSD filters (H-Filter and G-Filter), or the signal can be left unfiltered.

Table 1. Input mode setting

IMD0	IMD1	Mode name	Input format	DSD FIR filter
H	H	H	1bit, 64fs, DSD	H-Filter
H	L	G	1bit, 64fs, DSD	G-Filter
L	H	A	1bit, 64fs, DSD	None
L	L	D	24bit, 8fs, PCM	None

DSD Filter Characteristics

H-Filter frequency response

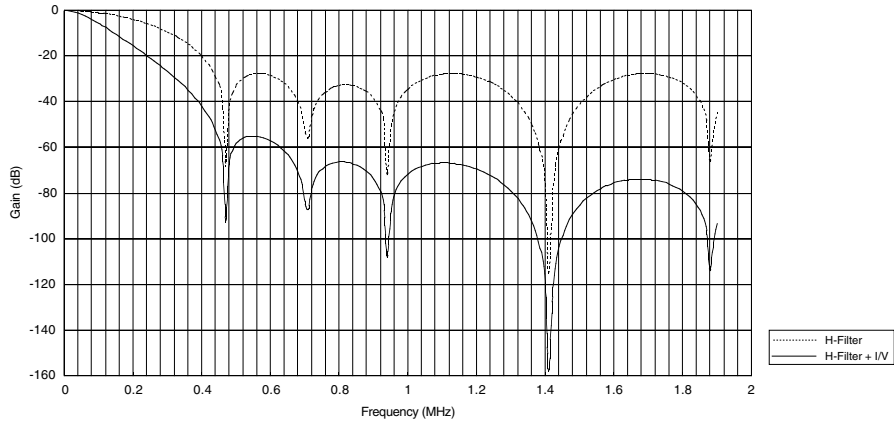

Figure 2. SM5866AS H-Filter + I/V Halfband Characteristics

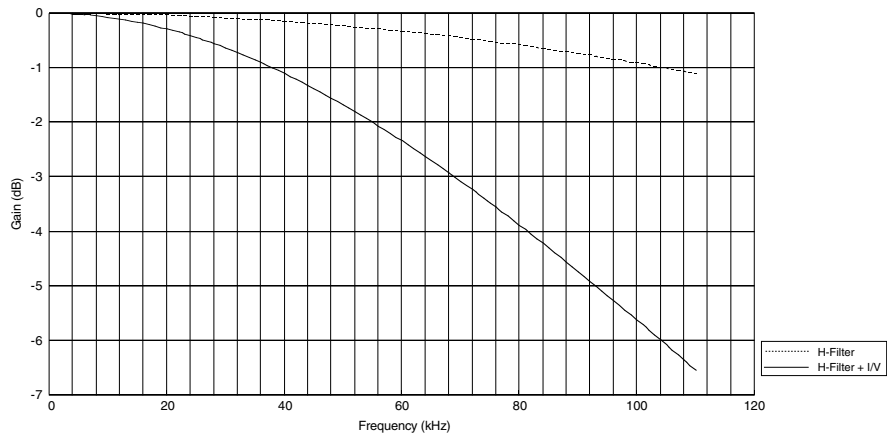

Figure 3. SM5866AS H-Filter + I/V Passband Characteristics

G-Filter frequency response

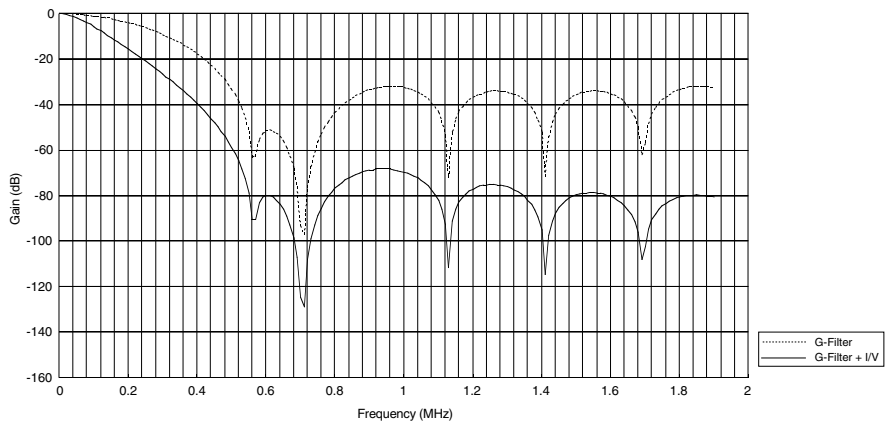

Figure 4. SM5866AS G-Filter + I/V Halfband Characteristics

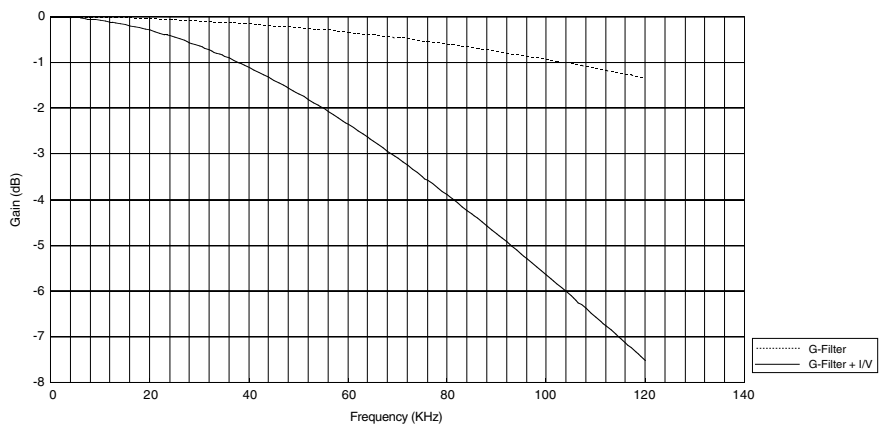

Figure 5. SM5866AS G-Filter + I/V Passband Characteristics

### DSD Mode Data Input Pins (SDI, SBCKA, SBCKD)

In DSD mode, the following 2 data input formats are supported.

(1) Normal input format (refer to “DSD normal input mode”)

A 64fs clock is input on SBCKA, and 64fs rate DSD data in sync with the clock is input on SDI. SBCKD is tied LOW.

(2) Phase-modulated format (refer to “DSD phase-modulated input mode”)

A 128fs clock is input on SBCKA, a 64fs clock is input on SBCKD, and 128fs rate phase-modulated DSD data in sync with both clocks is input on SDI.

The DSD data phase modulation depends on the clock interval. When the 64fs rate DSD data is “1”, SDI = HIGH if SBCKD = LOW or SDI = LOW if SBCKD = HIGH. When the DSD data is “0”, SDI = LOW if SBCKD = LOW or SDI = HIGH if SBCKD = HIGH.

### DSD Mode Bit Clock Polarity Select (BCPOL)

When BCPOL = LOW, data on SDI is read in on the rising edge of SBCKA. When BCPOL = HIGH, data on SDI is read in on the falling edge of SBCKA.

### DSD Mode Analog Output Polarity Select (DSPOL)

When DSPOL = HIGH, the analog output has in-phase polarity relative to the SDI input data. When DSPOL = LOW, the analog output has inverse-phase polarity relative to the SDI input data.

### PCM Mode Data Inputs (DI, BCKI, WCKI)

■ Input data format

Data is in MSB-first, 24-bit serial, 2s-complement format.

■ Jitter-free function

The SM5866AS reads serial input data on DI into the first-stage register in sync with the word clock on WCKI, while processed data is read into the last-stage register in sync with a clock derived by frequency division of the system clock. The word clock and the system clock continually undergo phase comparison and if a phase difference is detected, the system clock timing is corrected. Accordingly, if large jitter occurs in the word clock or the data sampling rate between input/output varies, the internal computational operation is not affected.

### System Reset (RSTN)

The SM5866AS must be reset under the following conditions:

■ At power-ON

■ When the CKI system clock stops or other similar occurrences

A reset occurs when RSTN goes LOW.

### PCM Mode Theoretical Quantization Noise

During PCM operation (D-Mode), residual quantization noise in the audio signal band to the high-frequency band, caused by the operation of the 3rd-order 23-level quantizer noise shaper, is greatly reduced. Figure 6 shows the theoretical quantization noise component for 16fs to 96fs operation.

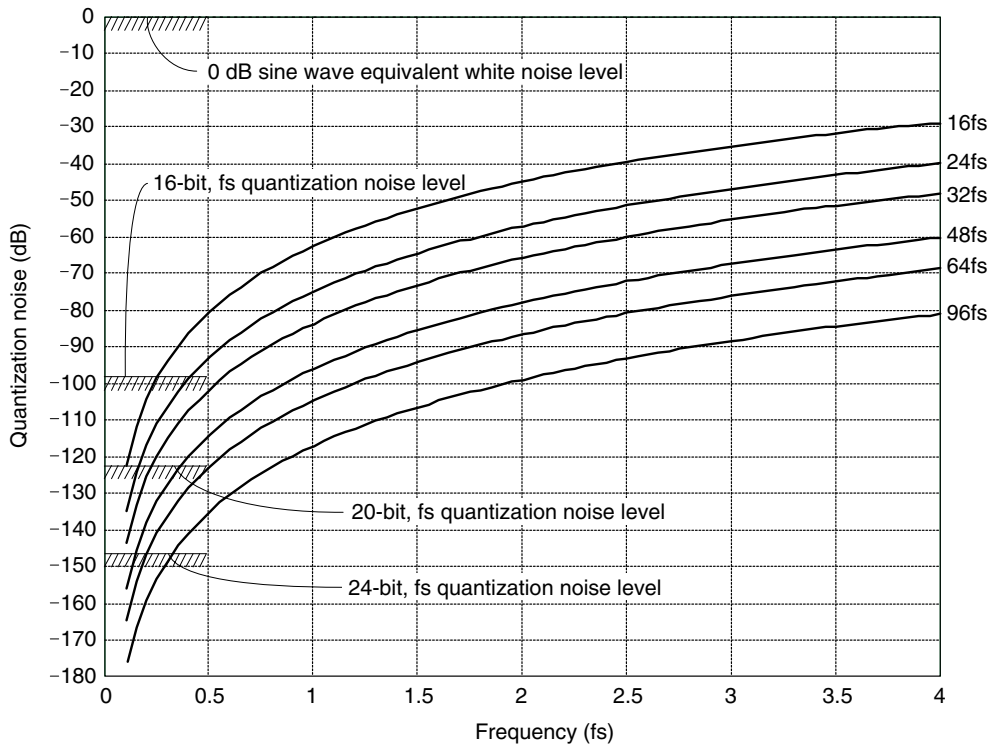

Figure 6. Quantization noise level

### PCM Mode Oversampling Operation

The SM5866AS receives signal output from either a 8-times or 4-times oversampling digital filter. Internally, this data is further oversampled up to the noise shaper operating rate. The internal oversampling ratio is determined automatically by the system clock frequency and the input sampling frequency. This internal oversampling ratio must be an integer, and therefore must satisfy the conditions shown in table 2.

Table 2. Internal oversampling conditions

$f_{WCKI}$ and $f_{CKI}$ conditions <sup>1</sup>	$f_{CKI} = f_{WCKI} \times 8 \times n$ <p>where <math>n = 1, 2, 3, \dots</math></p>
Noise shaper operating frequency	$f_{ns} = f_{WCKI} \times n = \frac{f_{CKI}}{8}$

1.  $f_{WCKI}$  = word clock frequency,  $f_{CKI}$  = input system clock frequency,  $n$  = internal oversampling ratio

## PCM Mode System Clock Frequency Example

With the circuit structure shown in figure 7, the oversampling rate for various sampling frequencies is given in table 3.

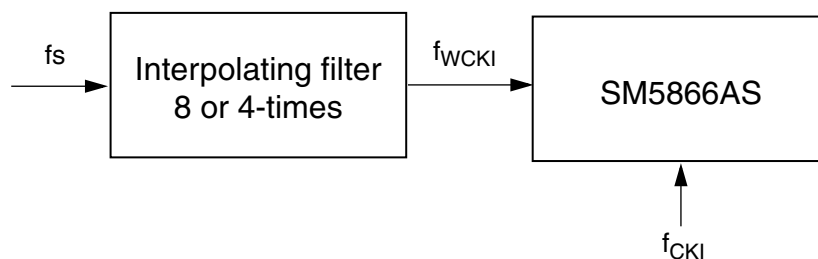

Figure 7. Circuit structure

Table 3. System clock frequency table

fs	f <sub>CKI</sub> system clock frequency	Noise shaper operating rate	Internal ratio (8fs input)	Internal ratio (4fs input)
16kHz	6.144MHz (384fs)	48fs	6	12
16kHz	8.192MHz (512fs)	64fs	8	16
16kHz	12.288MHz (768fs)	96fs	12	24
32kHz	6.144MHz (192fs)	24fs	3	6
32kHz	8.192MHz (256fs)	32fs	4	8
32kHz	12.288MHz (384fs)	48fs	6	12
32kHz	16.384MHz (512fs)	64fs	8	16
32kHz	24.576MHz (768fs)	96fs	12	24
44.1kHz	8.4672MHz (192fs)	24fs	3	6
44.1kHz	11.2896MHz (256fs)	32fs	4	8
44.1kHz	16.9344MHz (384fs)	48fs	6	12
44.1kHz	22.5792MHz (512fs)	64fs	8	16
44.1kHz	33.8688MHz (768fs)	96fs	12	24
48kHz	9.216MHz (192fs)	24fs	3	6
48kHz	12.288MHz (256fs)	32fs	4	8
48kHz	18.432MHz (384fs)	48fs	6	12
48kHz	24.576MHz (512fs)	64fs	8	16
48kHz	36.864MHz (768fs)	96fs	12	24
88.2kHz	16.9344MHz (192fs)	24fs	3	6
88.2kHz	22.5792MHz (256fs)	32fs	4	8
88.2kHz	33.8688MHz (384fs)	48fs	6	12
88.2kHz	45.1584MHz (512fs)	64fs	8	16
96kHz	18.432MHz (192fs)	24fs	3	6
96kHz	24.576MHz (256fs)	32fs	4	8
96kHz	36.864MHz (384fs)	48fs	6	12
176.4kHz	33.8688MHz (192fs)	24fs	3	6
176.4kHz	45.1584MHz (256fs)	32fs	4	8
192kHz	36.864MHz (192fs)	24fs	3	6



**PCM MODE INPUT TIMING EXAMPLE**

PCM mode input data in 24-bit word length, MSB-first, right-justified format

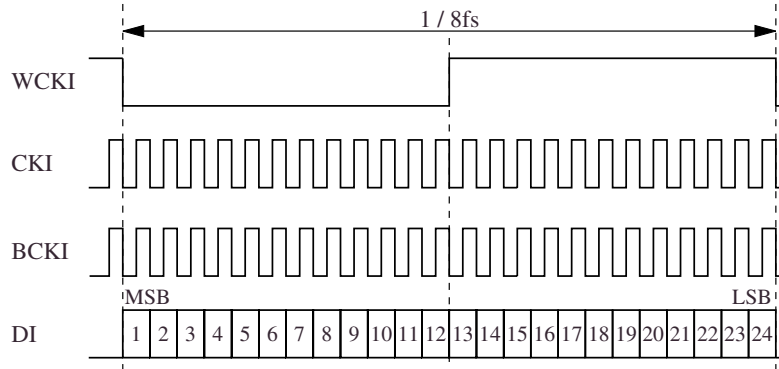

Figure 8. 192fs system clock input

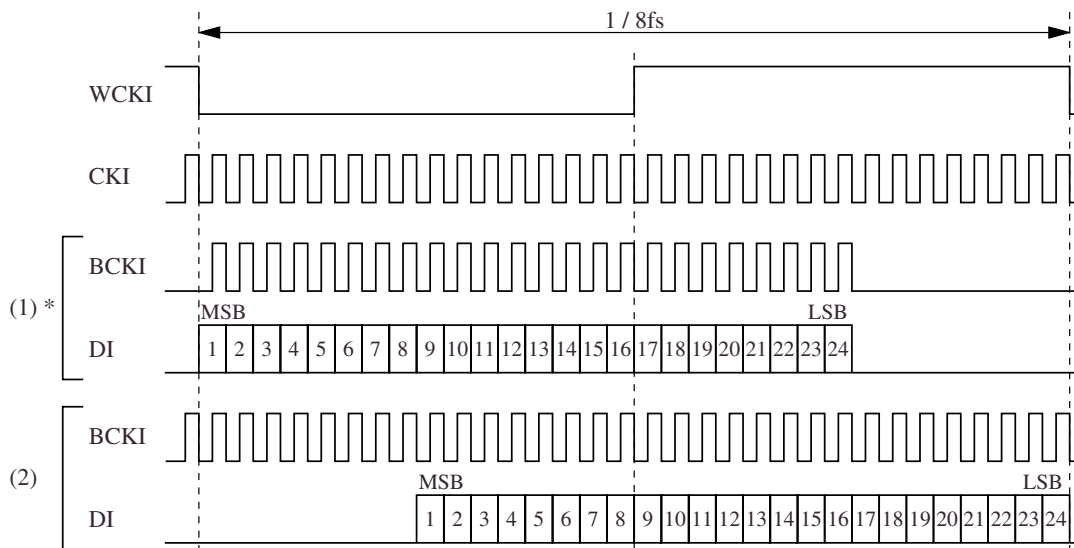

Figure 9. 256fs system clock input

\*: When the input data fits within the word clock cycle, the input data position (left/right) can be changed.

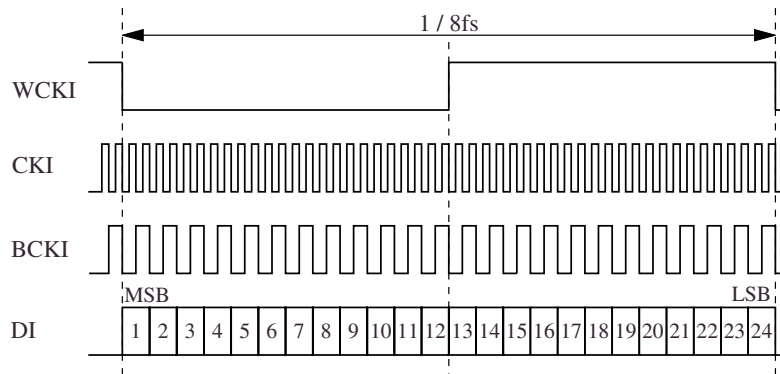

Figure 10. 384fs system clock input

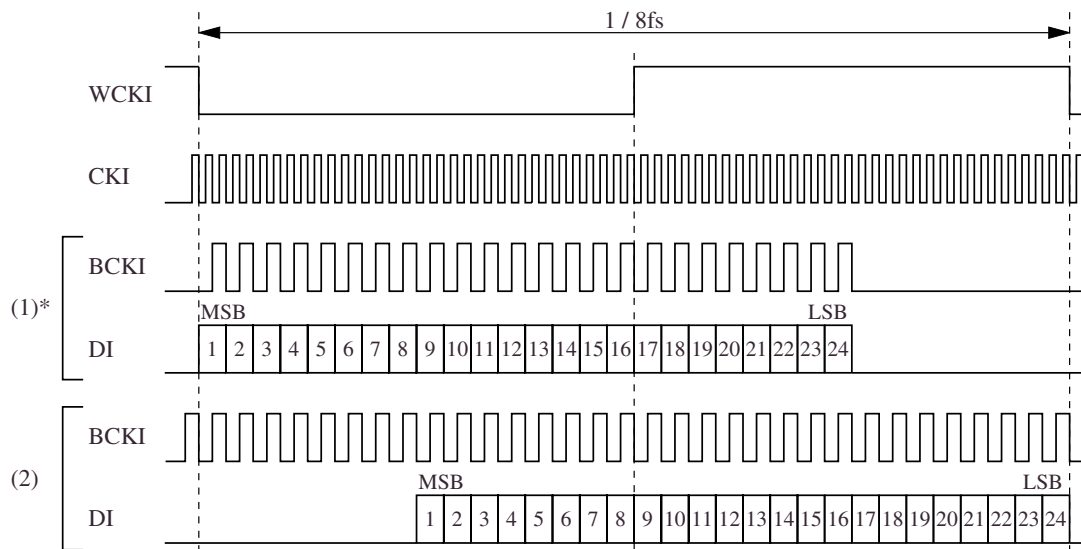

Figure 11. 512fs system clock input

\*: When the input data fits within the word clock cycle, the input data position (left/right) can be changed.

**TYPICAL CIRCUIT DIAGRAM**

**DSD Mode Input Interface Connection Example**

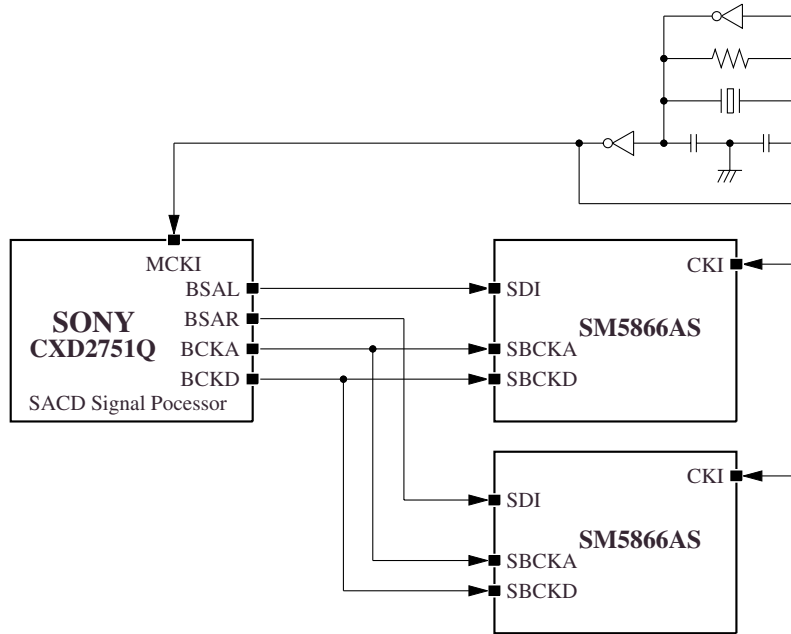

Figure 12. DSD Mode input interface connection example

**PCM Mode Input Interface Connection Example**

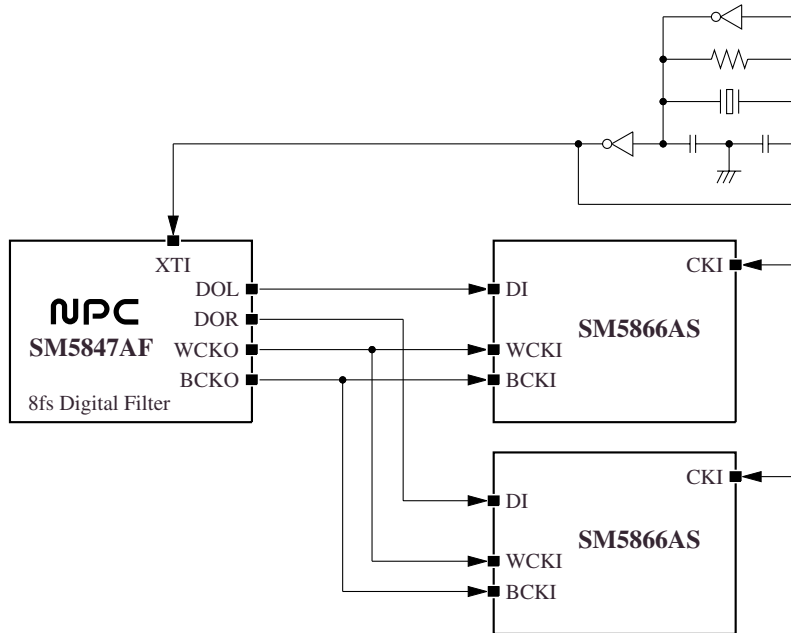

Figure 13. PCM Mode input interface connection example

Analog Output Connection Example

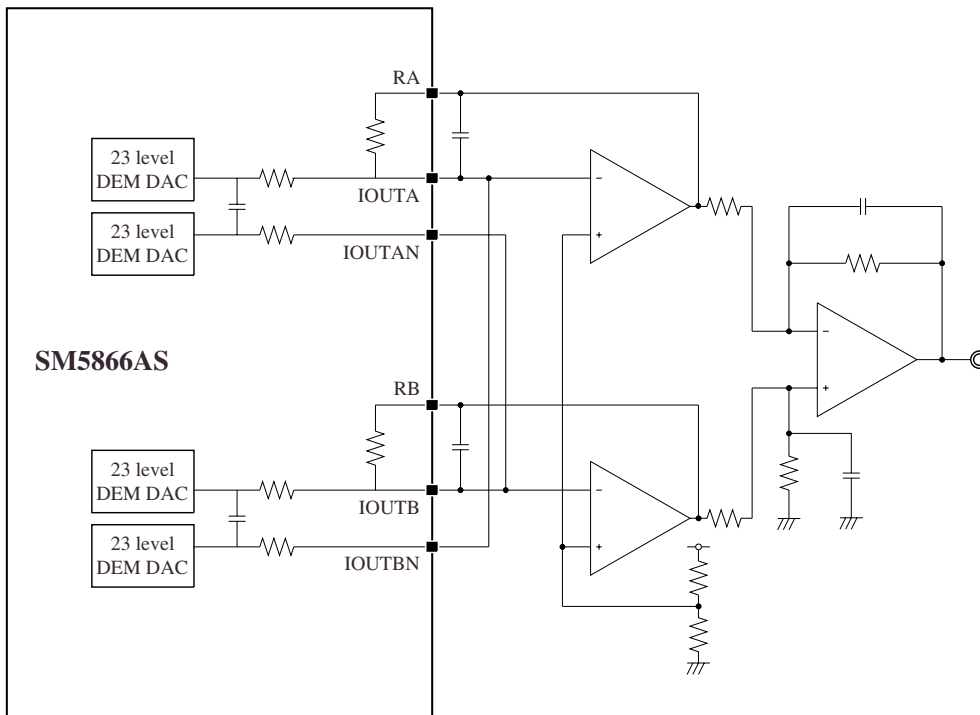

Figure 14. Connection example 1

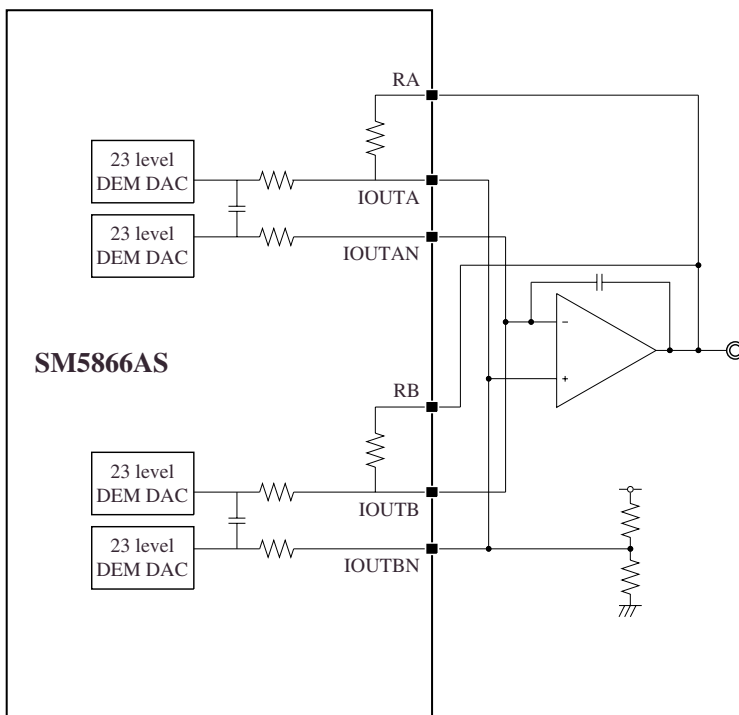

Figure 15. Connection example 2

Note:

The connection examples are connections for formats described earlier, with no specific guaranteed output analog characteristics. NPC does not accept responsibility for any patent issues relating to usage of application circuits published in this document.

**DYNAMICS CHARACTERISTICS**

**DSD mode (H-Mode) Dynamics Characteristics** (Under Measurement Condition in page 8)

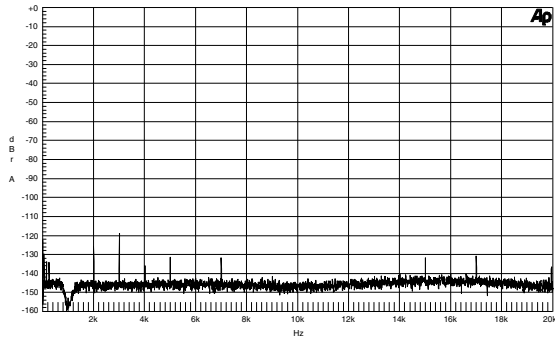

Figure 16. 0dB input FFT  
(with 1kHz notch filter 32768 pts. 8 average)

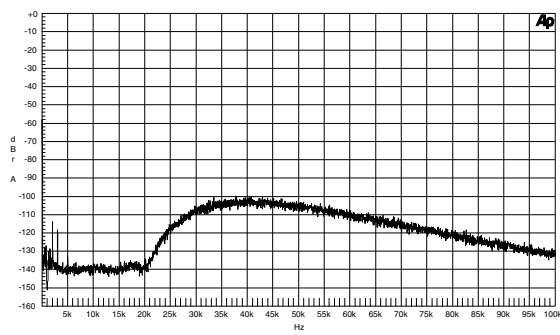

Figure 17. 0dB input FFT  
(with 1kHz notch filter 32768 pts. 8 average)

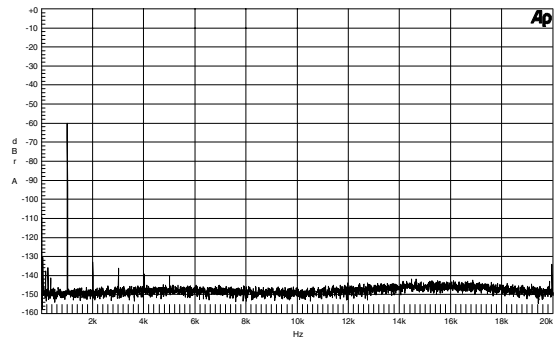

Figure 18. -60dB input FFT (32768 pts. 8 average)

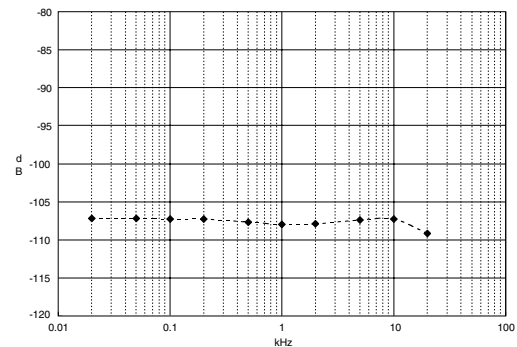

Figure 19. THD + N vs. frequency

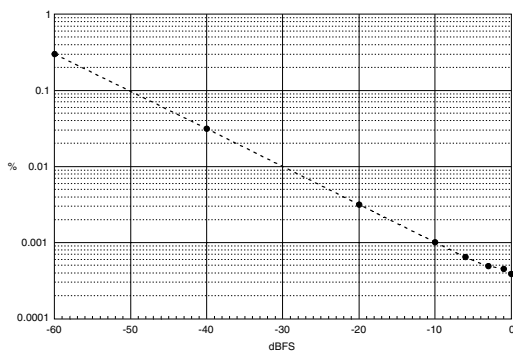

Figure 20. THD + N (%) vs. amplitude

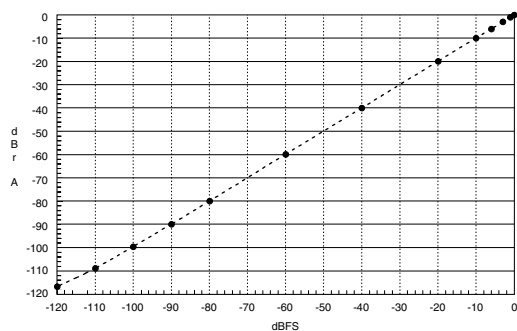

Figure 21. Linearity

Note. Input data: SUPER AUDIO CD DAC Test Disc (PHILIPS, 3122-783-00632)

PCM mode (D-Mode) Dynamics Characteristics (Under Measurement Condition in page 9)

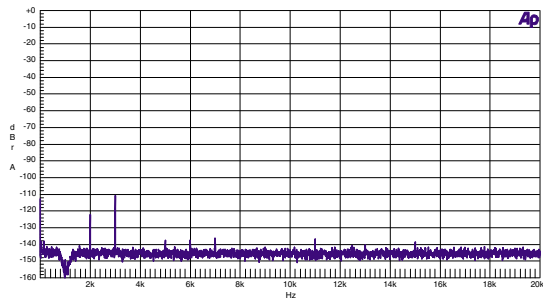

Figure 22. 0dB input FFT (with 1kHz notch filter 32768 pts. 8 average)

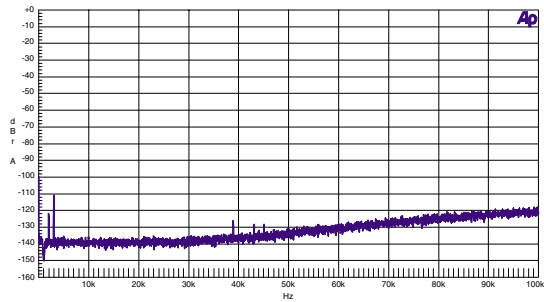

Figure 23. 0dB input FFT (with 1kHz notch filter 32768 pts. 8 average)

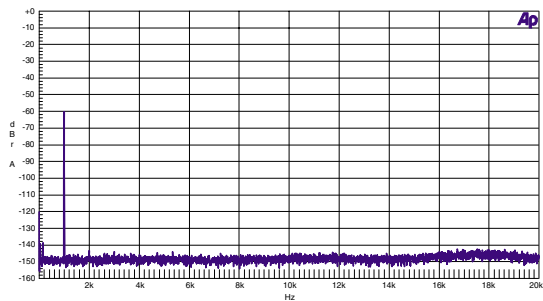

Figure 24. -60dB input FFT (32768 pts. 8 average)

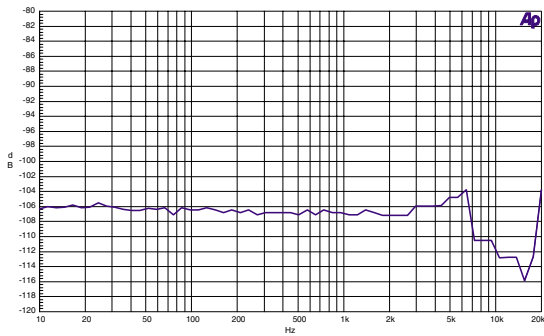

Figure 25. THD + N vs. frequency

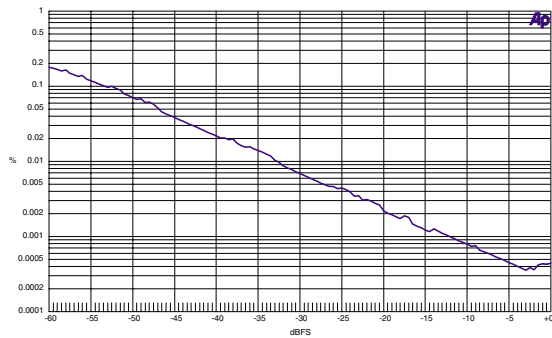

Figure 26. THD + N (%) vs. amplitude

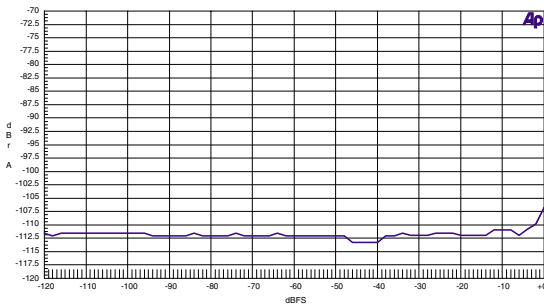

Figure 27. THD + N (dB) vs. amplitude

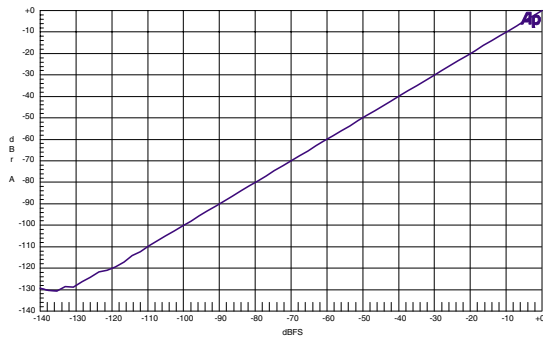

Figure 28. Linearity

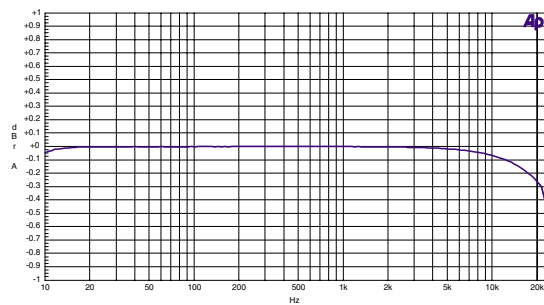

Figure 29. Frequency response

NIPPON PRECISION CIRCUITS INC. reserves the right to make changes to the products described in this data sheet in order to improve the design or performance and to supply the best possible products. Nippon Precision Circuits Inc. assumes no responsibility for the use of any circuits shown in this data sheet, conveys no license under any patent or other rights, and makes no claim that the circuits are free from patent infringement. Applications for any devices shown in this data sheet are for illustration only and Nippon Precision Circuits Inc. makes no claim or warranty that such applications will be suitable for the use specified without further testing or modification. The products described in this data sheet are not intended to use for the apparatus which influence human lives due to the failure or malfunction of the products. Customers are requested to comply with applicable laws and regulations in effect now and hereinafter, including compliance with export controls on the distribution or dissemination of the products. Customers shall not export, directly or indirectly, any products without first obtaining required licenses and approvals from appropriate government agencies.



NIPPON PRECISION CIRCUITS INC.

4-3, Fukuzumi 2-chome, Koto-ku,  
Tokyo 135-8430, Japan  
Telephone: +81-3-3642-6661  
Facsimile: +81-3-3642-6698  
<http://www.npc.co.jp/>  
Email: [sales@npc.co.jp](mailto:sales@npc.co.jp)

NC0017AE 2001.05