



Product List

SM894051L25, 25 MHz 4KB internal memory MCU
SM894051C25, 25 MHz 4KB internal memory MCU
SM894051C40, 40 MHz 4KB internal memory MCU

General Description

The SM894051 series product is an 8-bits single chip micro controller with 4KB flash embedded. It provides hardware features and a powerful instruction set, necessary to make it a versatile and cost effective controller for those applications demand up to 15 I/O pins or need up to 4KB flash memory either for program or for data or mixed. To program the flash block, a commercial programmer is capable to do it.

Ordering Information

SM894051ihhkL
yymm

i: process identifier {L=3.0V~3.6V,C=4.5V~ 5.5V}
hh: working clock in MHz {25, 40}
k: package type postfix {as below table}
yy: year, mm: month
v: version identifier {, A, B,...}
L: PB free identifier {no text is Non-PB free, "P" is PB free}

Feature

- | Working voltage: 3.0V ~ 3.6V For L Version
4.5V ~ 5.5V For C Version
- | General 8051 family compatible
- | 12 clocks per machine cycle
- | 4 KB internal flash memory
- | 128 bytes internal RAM
- | Two 16 bits timers/counters
- | 15 programmable I/O lines
- | Full duplex serial UART channel
- | Bit operation instruction
- | Industrial Level
- | 8-bits unsigned division
- | 8-bits unsigned multiply
- | BCD arithmetic
- | Direct addressing
- | Indirect addressing
- | Two priority level interrupt
- | Power save modes:
Idle mode
Power down mode (provide H/W wake-up function)
- | Code protection function
- | One watch dog timer (WDT)
- | Low EMI (inhibit ALE)
- | On-chip Analog Comparator
- | Direct LED Drive Output (Default = 1)

Taiwan
4F, No. 1 Creation Road 1,
Science-based Industrial Park,
Hsinchu, Taiwan 30077

TEL: 886-3-578-3344 #2667
886-3-579-2987
FAX: 886-3-5792960
886-3-5780493



Package Spec.

Package	Pin / PAD	Frequency
20L PDIP	Figure 1	25 MHz at 3.3V and 40MHz at 5V
20L SOIC	Figure 2	25 MHz at 3.3V and 40MHz at 5V

Pin Configuration

Figure 1 20L PDIP Package

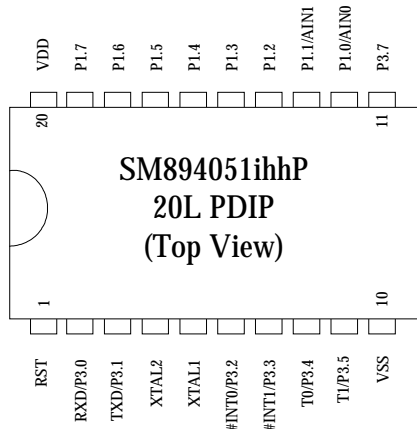
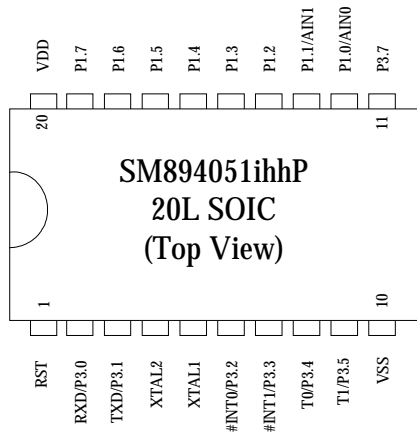
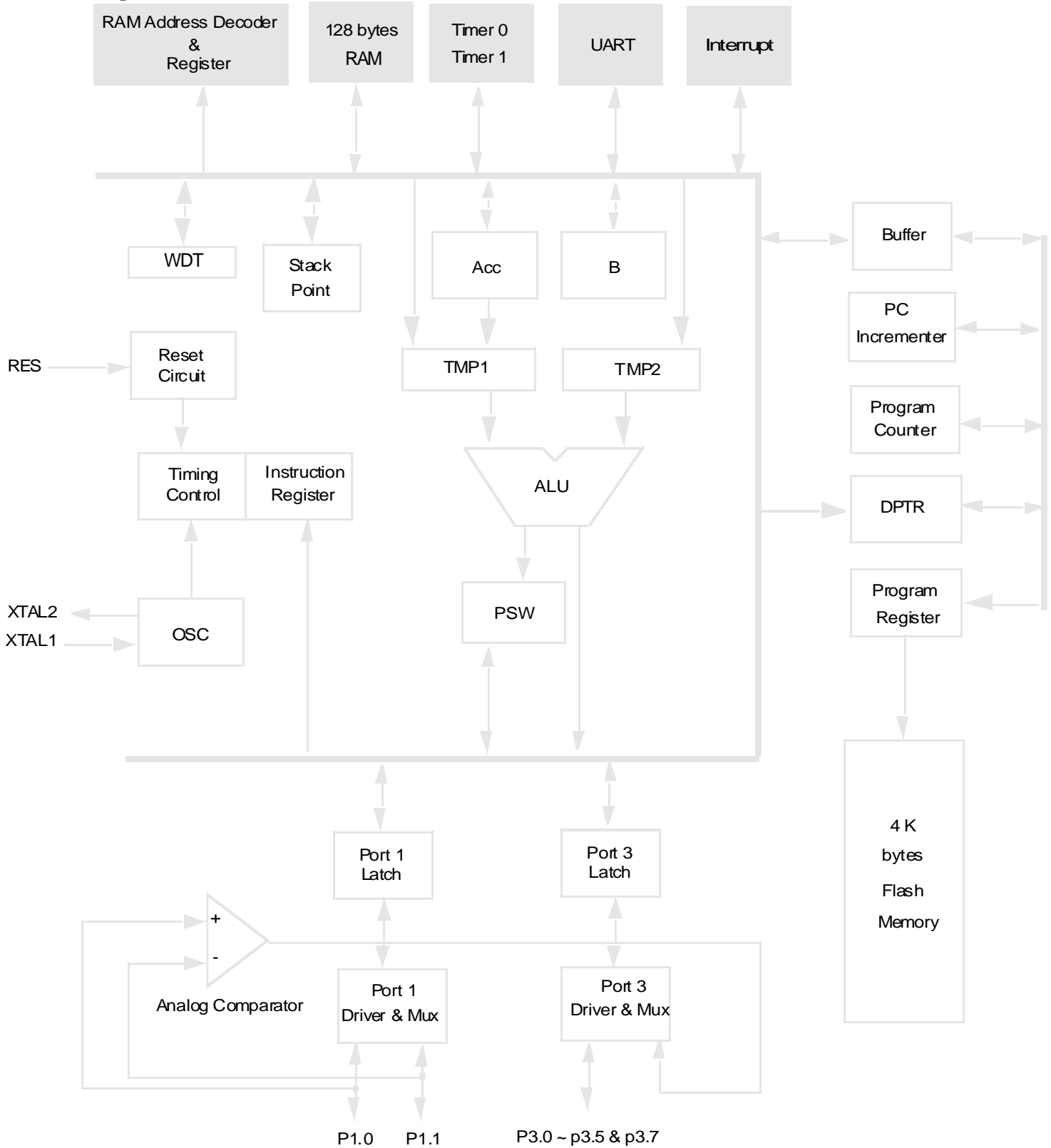

Figure 2 20L SOIC Package





Block Diagram





Pin Description (20L PDIP / 20L SOIC)

Pin	Symbol	Active	I/O	Names
1	RST	H	i	Reset
2	P3.0/RXD		i/o	bit 0 of port 3 & receive data
3	P3.1/TXD		i/o	bit 1 of port 3 & transmit data
4	XTAL2		o	Crystal out
5	XTAL1		i	Crystal in
6	P3.2/#INT0	-/L	i/o	bit 2 of port 3 & low true interrupt 0
7	P3.3/#INT1	-/L	i/o	bit 3 of port 3 & low true interrupt 1
8	P3.4/T0		i/o	bit 4 of port 3 & timer 0
9	P3.5/T1		i/o	bit 5 of port 3 & timer 1
10	VSS			Sink Voltage, Ground
11	P3.7		i/o	bit 7 of port 3
12	P1.0/AIN0		i/o	bit 0 of port 1 & positive 0 of the on chip analog comparator
13	P1.1/AIN1		i/o	bit 1 of port 1 & positive 1 of the on chip analog comparator
14	P1.2		i/o	bit 2 of port 1
15	P1.3		i/o	bit 3 of port 1
16	P1.4		i/o	bit 4 of port 1
17	P1.5		i/o	bit 5 of port 1
18	P1.6		i/o	bit 6 of port 1
19	P1.7		i/o	bit 7 of port 1
20	VDD			Drive voltage, +5 Vcc

Special Function Register (SFR) Memory Map

\$F8								\$FF
\$F0	B 0000 0000							\$F7
\$E8								\$EF
\$E0	ACC 0000 0000							\$E7
\$D8								\$DF
\$D0	PSW 0000 0000							\$D7
\$C8								\$CF
\$C0								\$C7
\$B8	IP 0000 0000						SCONF 0xxx xxx0	\$BF
\$B0	P3 1111 1111							\$B7
\$A8	IE 0000 0000							\$AF
\$A0								\$A7
\$98	SCON 0000 0000	SBUF xxxx xxxx					WDTC 0x0x x000	\$9F
\$90	P1 1111 1111			LEDENP1 0000 0000		LEDENP3 0000 0000	WDTKEY 0000 0000	\$97
\$88	TCON 0000 0000	TMOD 0000 0000	TL0 0000 0000	TL1 0000 0000	TH0 0000 0000	TH1 0000 0000		\$8F
\$80		SP 0000 0111	DPL 0000 0000	DPH 0000 0000	(Reserved)		PCON 0000 0000	\$87

Note: The text of SFRs with bold type characters are Extension Special Function Registers for SM894051

Specifications subject to change without notice contact your sales representatives for the most recent information.



Addr	SFR	Reset	7	6	5	4	3	2	1	0
93H	LEDENP1	00H	LEDEN P17	LEDEN P16	LEDEN P15	LEDEN P14	LEDEN P13	LEDEN P12	LEDEN P11	LEDEN P10
95H	LEDENP3	00H	LEDEN P37	Unused	LEDEN P35	LEDEN P34	LEDEN P33	LEDEN P32	LEDEN P31	LEDEN P30
97H	WDTKEY	00H	WDT KEY7	WDT KEY6	WDT KEY5	WDT KEY4	WDT KEY3	WDT KEY2	WDT KEY1	WDT KEY0
9FH	WDTC	0*0**000	WDTE	Reserve	CLEAR	Unused	Unused	PS2	PS1	PS0
BFH	SCONF	0*****0	WDR	Unused	Unused	Unused	Unused	Reserve	Unused	ALEI

Operating Conditions

Symbol	Description	Min.	Typ.	Max.	Unit.	Remarks
TA	Operating temperature	-40	25	85	°C	Ambient temperature under bias
TS	Storage temperature	-55	25	155	°C	Damage to devices could occur
VCC5	Supply voltage	4.5	5.0	5.5	V	
VCC3.3	Supply voltage	3.0	3.3	3.6	V	
Fosc 25	Oscillator Frequency			25	MHz	For 3.3V application
Fosc 40	Oscillator Frequency			40	MHz	For 5.0V application

DC Characteristic

VCC = 5V (±10%), VSS=0V TA= -40°C to 85°C

SYMBOL	PARAMETER	TEST CONDITIONS	LIMITS		UNIT
			MIN	MAX	
VCC	Supply Voltage		4.5	5.5	V
ICC	Supply current operating	See notes 1 f _{CLK} = 12MHz VCC = 5.5V		20	mA
IID	Supply current IDLE Mode	See note 2 f _{CLK} = 12MHz VCC = 5.5V		6.5	mA
IPD	Supply current Power-Down MODE	See note 3 ; VCC (= 5.5V)		30	µA
INPUT					
VIL1	Input LOW voltage, P1, P3		-0.5	0.8	V
VIL2	Input LOW voltage, RES, XTAL1		0	0.8	V
VIH1	Input HIGH voltage, P1, P3		2.0	V _{CC} +0.5	V
VIH2	Input HIGH voltage, RES, XTAL1		70%VCC	V _{CC} +0.5	V
IIL	Input current LOW level, P3.0~P3.5, P3.7	VIN = 0.45V		-50	µA
ITL	Transition current High to Low, P3.0~P3.5, P3.7	VIN = 2.0 V		-650	µA
ILI	Input leakage current, P1.0~P1.1	0.45V < VIN < VCC-0.3V		±10	µA
OUTPUT					
VOL1	Output LOW voltage, P1.2~P1.7, P3.0~P3.5, P3.7	IOL = 8mA · VCC=5.0V		0.45	V
VOL2	Output LOW voltage, P1.0~P1.1	IOL = 6.5mA · VCC =5.0V		0.45	V
VOH1	Output High voltage, P3.0~P3.5, P3.7	IOH = -800uA · VCC =5.0V	2.4		V
	Output High voltage, P1.2~P1.7	IOH = -800uA · VCC =5.0V	2.4		V
VOH2	Output High voltage, P1.0~P1.1 (For comparator pin)	IOH = -60µA · VCC =5.0V	2.4		V
RRST	Internal RESET pull-down resistor	VIN = 5.0 V	50	300	kΩ
CIO	Pin capacitance	Test freq=1MHz, TA=25°C		10	pF



VCC = 3.3V (±10%), VSS=0V, TA= -40°C to 85°C

SYMBOL	PARAMETER	TEST CONDITIONS	LIMITS		UNIT
			MIN	MAX	
VCC	Supply Voltage		3.0	3.6	V
ICC	Supply current operating	See note 1 $f_{CLK} = 12\text{MHz}$ VCC = 3.6V		10	mA
IID	Supply current IDLE Mode	See note 2 $f_{CLK} = 12\text{MHz}$ VCC = 3.6V		5	mA
IPD	Supply current Power-Down MODE	See note 3 ; VCC (= 3.6V)		20	µA
INPUT					
VIL1	Input LOW voltage, P1, P3	VCC = 3.6V	0	0.2 VCC -0.2	V
VIL2	Input LOW voltage, RST	VCC = 3.6V	0	0.2 VCC -0.2	V
VIL3	Input LOW voltage, XTAL1	VCC = 3.6V	0	0.2 VCC -0.2	V
VIH1	Input HIGH voltage, P1, P3	VCC = 3.6V	0.6 VCC -0.4	VCC + 0.2	V
VIH2	Input HIGH voltage, RST	VCC = 3.6V	0.6 VCC -0.4	VCC + 0.2	V
VIH3	Input HIGH voltage, XTAL1	VCC = 3.6V	0.8 VCC	VCC + 0.2	V
IIN1	Input current LOW level P1 ,P3	VCC = 3.0V ~3.6V, VIN = 0.45V.	-10	50	µA
ITL	Transition current High to Low P3.0~P3.5, P3.7	See note 4 VCC = 3.6V, VIN = 2.0 V	-75	400	µA
ILI	Input leakage current P1.0~P1.1	VCC = 3.0V ~3.6V, 0.45V<VIN<VCC	-10	10	µA
OUTPUT					
VOL1	Output LOW voltage, P1.2~P1.7, P3.0~P3.5, P3.7	IOL = 6mA , VCC =3.3V		0.4	V
VOL2	Output Low voltage P1.0~P1.1	IOL = 5mA , VCC =3.3V		0.4	V
VOH1	Output High voltage P3.0~P3.5, P3.7	IOH =-300uA , VCC =3.3V	2.4		V
	Output High voltage, P1.2~P1.7	IOH =-300uA , VCC =3.3V	2.4		V
VOH2	Output High voltage, P1.0~P1.1	IOH =-20µA , VCC =3.3V	2.4		V
ISK1	Sink Current P1, P3	VCC = 3.3V, VIN = 0.4 V		6	mA
ISR1	Source Current P1, P3	VCC = 3.3V, VIN = 2.4 V		-80	uA
RRST	Internal RESET pull-down resistor		50	300	kΩ
CIO	Pin capacitance	Test freq=1MHz, TA=25°C		10	pF

NOTES FOR DC ELECTRICAL CHARACTERISTICS

- The operating supply current is measured with all output disconnected;
XTAL1 driven with $t_r = t_f = 5\text{ns}$; VIL = VSS+0.5V; VIH=VCC-0.5V; XTAL2 not connect;
- The IDLE MODE supply current is measured with all output pins disconnected;
XTAL1 driven with $t_r = t_f = 5\text{ns}$; VIL = VSS+0.5V; VIH=VCC-0.5V; XTAL2 not connect;
- The POWER-DOWN MODE supply current is measured with all output pins disconnected;
VIL = VSS+0.5V; VIH=VCC-0.5V; XTAL2 not connect;
- Port 1, 3 sources a transition current when they are being externally driven from HIGH to LOW. The transition current reaches its maximum value when VIN is approximately 2V.

ICC Active Mode Test Circuit:

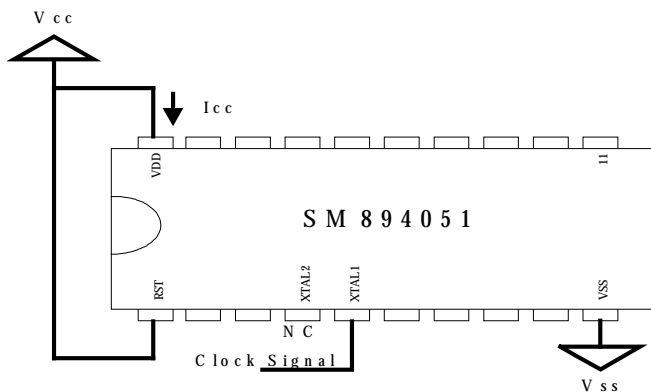

Specifications subject to change without notice contact your sales representatives for the most recent information.

SM894051 V1.0 March 2006



AC Characteristic

VCC=3.3V±10%, VSS=0V, tclk min = 1/ fmax(maximum operating frequency)

TA= -40°C to +85°C

Symbol	FIGURE	PARAMETER	MIN	MAX	UNIT
External Clock drive into XTAL1					
tCLK	4	Xtal1 Period	40(Note1)	-	ns
tCLKH	4	Xtal1 HIGH time	20	-	ns
tCLKL	4	Xtal1 LOW time	20	-	ns
tCLKR	4	XTAL1 rise time	-	10	ns
tLLIV	4	XTAL1 fall time	-	10	ns
tCYC	4	Controller cycle time = tCLK / 12	3.33	-	ns

NOTES:

1. Operating at 25MHz.

Symbol	FIGURE	PARAMETER	MIN	MAX	UNIT
UART					
tXLXL	5	Serial port clock time	12tCLK		ns
tQVXH	5	Output data setup to clock rising edge	10tCLK-133		ns
tXHQX	5	Output data hold after clock rising edge	2tCLK-117		ns
tXHDX	5	Input data hold after clock rising edge	0		ns
tXHDV	5	Clock rising edge to input data valid		10tCLK-133	ns

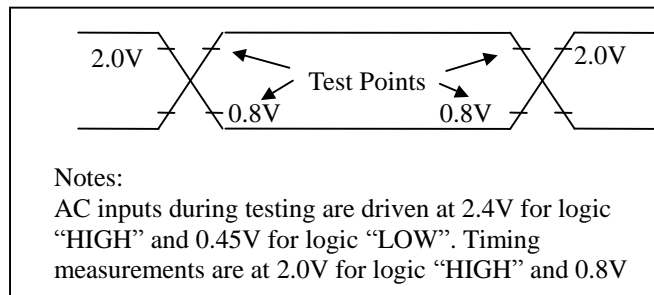

Notes:
AC inputs during testing are driven at 2.4V for logic "HIGH" and 0.45V for logic "LOW". Timing measurements are at 2.0V for logic "HIGH" and 0.8V

Figure 4 AC Testing Input/Output

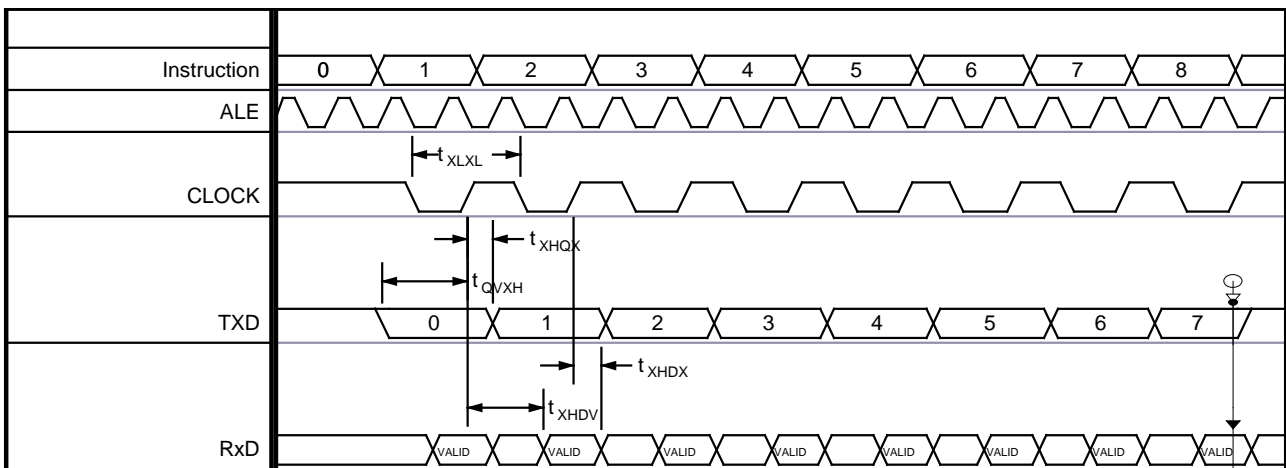

Figure5 UART waveform in Shift Register MODE

Specifications subject to change without notice contact your sales representatives for the most recent information.



Instruction Set

The SM894051 uses the powerful instruction set of 80C51. It consists of 45 single-byte, 47 two-byte, and 15 three-byte instructions. Among them 65 instruction are executed in 1 machine-cycle, 40 instructions in 2 machine-cycles, and the multiply, 2 instructions in 4 machine-cycles.

A summary of the instruction set is given in Table 3.

Addressing Mode

Notes on instruction set and address modes:

Rn		Register R7-R0 of the currently selected register bank.
direct		8-bits internal data location's address. This could be internal DATA RAM location (0-127) or a SFR [i.e., I/O port, control register, status register, etc. (128-255)]
@Ri		8-bits RAM location addressed indirectly through register R1 or R0 of the actual register bank
#data		8-bits constant included in the instruction
#data16		16-bits constant included in the instruction
addr11		11-bits destination address. Used by ACALL and AJMP. The branch can be anywhere within the same 2 Kbytes page of program memory as the first byte of the following instruction.
rel		Signed (2's complement) 8-bits offset byte. Used by SJMP and all conditional jumps. Range is -128 to +127 bytes relative to first byte of the following instruction.
bit		Direct addressed bit in internal data RAM or SFR

Table 3: A Summary of the instruction set

Mnemonic		OPERATION	BYTE	CYCLE
Arithmetic Instructions				
ADD	A,Rn	$A = A + Rn$	1	1
ADD	A,direct	$A = A + \text{direct}$	2	1
ADD	A,@Ri	$A = A + \langle @Ri \rangle$	1	1
ADD	A,#data	$A = A + \#data$	2	1
ADDC	A,Rn	$A = A + Rn + C$	1	1
ADDC	A,direct	$A = A + \text{direct} + C$	2	1
ADDC	A,@Ri	$A = A + @Ri + C$	1	1
ADDC	A,#data	$A = A + \#data + C$	2	1
SUBB	A,Rn	$A = A - Rn - C$	1	1
SUBB	A,direct	$A = A - \text{direct} - C$	2	1
SUBB	A,@Ri	$A = A - \langle @Ri \rangle - C$	1	1
SUBB	A,#data	$A = A - \#data - C$	2	1
INC	A	$A = A + 1$	1	1
INC	Rn	$Rn = Rn + 1$	1	1
INC	direct	$\text{direct} = \text{direct} + 1$	2	1
INC	@Ri	$\langle @Ri \rangle = \langle @Ri \rangle + 1$	1	1
DEC	A	$A = A - 1$	1	1
DEC	Rn	$Rn = Rn - 1$	1	1
DEC	direct	$\text{direct} = \text{direct} - 1$	2	1
DEC	@Ri	$\langle @Ri \rangle = \langle @Ri \rangle - 1$	1	1
INC	DPTR	$DPTR = DPTR - 1$	1	2
MUL	AB	$B:A = A \times B$	1	4
DIV	AB	$A = \text{INT}(A/B)$ $B = \text{MOD}(A/B)$	1	4
DA	A	Decimal adjust ACC	1	1
Logical Instructions				
ANL	A,Rn	$A .AND. Rn$	1	1
ANL	A,direct	$A .AND. \text{direct}$	2	1
ANL	A,@Ri	$A .AND. \langle @Ri \rangle$	1	1
ANL	A,#data	$A .AND. \#data$	2	1
ANL	direct,A	$\text{direct} .AND. A$	2	1
ANL	direct,#data	$\text{direct} .AND. \#data$	3	2
ORL	A,Rn	$A .OR. Rn$	1	1
ORL	A,direct	$A .OR. \text{direct}$	2	1
ORL	A,@Ri	$A .OR. \langle @Ri \rangle$	1	1
ORL	A,#data	$A .OR. \#data$	2	1
ORL	direct,A	$\text{direct} .OR. A$	2	1
ORL	direct,#data	$\text{direct} .OR. \#data$	3	2

Specifications subject to change without notice contact your sales representatives for the most recent information.



XRL	A,Rn	A .XOR. Rn	1	1
XRL	A,direct	A .XOR. direct	2	1
XRL	A,@Ri	A .XOR. <@Ri>	1	1
XRL	A,#data	A .XOR. #data	2	1
XRL	direct,A	direct .XOR. A	2	1
XRL	direct,#data	direct .XOR. #data	3	2
CLR	A	A = 0	1	1
CPL	A	A = /A	1	1
RL	A	Rotate ACC Left 1 bit	1	1
RLC	A	Rotate Left through Carry	1	1
RR	A	Rotate ACC Right 1 bit	1	1
RRC	A	Rotate Right through Carry	1	1
SWAP	A	Swap Nibbles in A	1	1
Data Transfers Instructions				
MOV	A,Rn	A = Rn	1	1
MOV	A,direct	A = direct	2	1
MOV	A,@Ri	A = <@Ri>	1	1
MOV	A,#data	A = #data	2	1
MOV	Rn,A	Rn = A	1	1
MOV	Rn,direct	Rn = direct	2	2
MOV	Rn,#data	Rn = #data	2	1
MOV	direct,A	direct = A	2	1
MOV	direct,Rn	direct = Rn	2	2
MOV	direct,direct	direct = direct	3	2
MOV	direct,@Ri	direct = <@Ri>	2	2
MOV	direct,#data	direct = #data	2	1
MOV	@Ri,A	<@Ri> = A	1	1
MOV	@Ri,direct	<@Ri> = direct	2	2
MOV	@Ri,#data	<@Ri> = #data	2	1
MOV	DPTR,#data16	DPTR = #data16	3	2
MOVC	A,@A+DPTR	A = code memory[A+DPTR]	1	2
MOVC	A,@A+PC	A = code memory[A+PC]	1	2
PUSH	direct	INC SP: MOV '@'SP', < direct >	2	2
POP	direct	MOV < direct >, '@SP': DEC SP	2	2
XCH	A,Rn	ACC and < Rn > exchange data	1	1
XCH	A,direct	ACC and < direct > exchange data	2	1
XCH	A,@Ri	ACC and < Ri > exchange data	1	1
XCHD	A,@Ri	ACC and @Ri exchange low nibbles	1	1
Boolean Instructions				
CLR	C	C = 0	1	1
CLR	bit	bit = 0	2	1
SETB	C	C = 1	1	1
SETB	bit	bit = 1	2	1
CPL	C	C = /C	1	1
CPL	bit	bit = /bit	2	1
ANL	C,bit	C = C .AND. bit	2	2
ANL	C,/bit	C = C .AND. /bit	2	2
ORL	C,bit	C = C .OR. bit	2	2
ORL	C,/bit	C = C .OR. /bit	2	2
MOV	C,bit	C = bit	2	1
MOV	bit,C	bit = C	2	2
JC	rel	Jump if C= 1	2	2
JNC	rel	Jump if C= 0	2	2
JB	bit,rel	Jump if bit = 1	3	2
JNB	bit,rel	Jump if bit = 0	3	2
JBC	bit,rel	Jump if C = 1	3	2
Jump Instructions				
ACALL	addr11	Call Subroutine only at 2k bytes Address	2	2
LCALL	addr16	Call Subroutine in max 64K bytes Address	3	2
RET		Return from subroutine	1	2
RETI		Return from interrupt	1	2
AJMP	addr11	Jump only at 2k bytes Address	2	2
LJMP	addr16	Jump to max 64K bytes Address	3	2
SJMP	rel	Jump on at 256 bytes	2	2
JMP	@A+DPTR	Jump to A+ DPTR	1	2
JZ	rel	Jump if A = 0	2	2
JNZ	rel	Jump if A ≠ 0	2	2

Specifications subject to change without notice contact your sales representatives for the most recent information.

SM894051 V1.0 March 2006



CJNE	A, direct,rel	Jump if A \neq < direct >	3	2
CJNZ	A, #data,rel	Jump if A \neq < #data >	3	2
CJNZ	Rn, #data,rel	Jump if Rn \neq < #data >	3	2
CJNZ	@Ri, #data,rel	Jump if @Ri \neq < #data >	3	2
DJNZ	Rn,rel	Decrement and jump if Rn not zero	2	2
DJNZ	direct,rel	Decrement and jump if direct not zero	3	2
NOP		No Operation	1	1

Limited on Certain Instructions

Branching instructions:

The certain instructions related to branching or jumping should be restricted. When the programmer execute the branching instructions like AJMP, LJMP, ACALL, LCALL, SJMP etc..., they have responsibility to ensure that the destination branching address don't be over internal program memory size. SM894051 contain 4K bytes program memory and its location is from 00H to 0FFFH.

Data Memory, MOVX-related instructions:

SM894051 contains 128 bytes internal data memory, and it doesn't support external data memory access. Therefore, SM894051 doesn't include MOVX instructions.

Limited on down mode wake-up

SM894051 has two ways to wake-up power down mode. One of them is hardware reset. The other one is that using external interrupt (#INT0, #INT1) to wake-up power down mode and the external interrupt must be set for level trigger.

I/O Pin Configuration

Port 1:

The ports P1.2 to P1.7 have internal pull-up resistor. The ports P1.0 to P1.1 are open-drain configuration, so they require external pull-up resistor to pull low. And P1.0 and P1.1 also used as the positive input (AIN0) and the negative input (AIN1) of the on chip analog comparator.

As long as the voltage level of P1.0 is greater than P1.1, the output voltage level of the on-chip analog comparator is "1". And this result will be stored in the bit 6 of the port 3 SFR.

Port 3:

The Port 3 are 7-bits bi-directional I/O pins which include P3.0 to P3.5 and P3.7. The P3.6 doesn't be used as general purpose I/O pin, and the output pin of the on-chip analog comparator connects to the P3.6 which is hard-wired as an input.

I/O are provided with LED driving capacity

LEDEN (LEDENP1, 93H)

Bit7	Bit6	Bit5	Bit4	Bit3	Bit2	Bit1	Bit0
LEDEN P17	LEDEN P16	LEDEN P15	LEDEN P14	LEDEN P13	LEDEN P12	LEDEN P11	LEDEN P10

LEDEN (LEDENP3, 95H)

Bit7	Bit6	Bit5	Bit4	Bit3	Bit2	Bit1	Bit0
LEDEN P37	Unused	LEDEN P35	LEDEN P34	LEDEN P33	LEDEN P32	LEDEN P31	LEDEN P30

When I/O Ports (Port1 & Port3) output low voltage, they are provided with more sink current (IIL about 20mA) to drive LED by setting LED enable bit.

For example, when setting LEDNP1 [0] to high then P1.0 is provided with more sink current (IIL) to drive LED. And so on, each I/O can be set to drive LED by setting correspondent register.

Specifications subject to change without notice contact your sales representatives for the most recent information.

SM894051 V1.0 March 2006



Extension Function Description

Watch Dog Timer

The Watch Dog Timer (WDT) is a 16-bits free-running counter that generate reset signal if the counter overflows. The WDT is useful for systems that are susceptible to noise, power glitches, or electronics discharge which causing software dead loop or runaway. The WDT function can help user software recover from abnormal software condition. The WDT is different from Timer0, Timer1 of general 8051. To prevent a WDT reset can be done by software periodically clearing the WDT counter. User should check WDR bit of SCONF register whenever unpracticed reset happened.

The purpose of the secure procedure is to prevent the WDTC value from being changed when system runaway. There is a 250KHz RC oscillator embedded in chip. Set WDTE = "1" will enable the RC oscillator and the frequency is independent to the system frequency.

To enable the WDT is done by setting 1 to the bit 7 (WDTE) of WDTC. After WDTE set to 1, the 16-bits counter starts to count with the RC oscillator. It will generate a reset signal when overflows. The WDTE bit will be cleared to 0 automatically when SM894051 been reset, either hardware reset or WDT reset.

To reset the WDT is done by setting 1 to the CLEAR bit of WDTC before the counter overflow. This will clear the content of the 16-bits counter and let the counter re-start to count from the beginning.

Watch Dog Timer Registers

Watch Dog Key Register

WDTKEY (\$97)

Bit7	Bit6	Bit5	Bit4	Bit3	Bit2	Bit1	Bit0
WDT KEY7	WDT KEY6	WDT KEY5	WDT KEY4	WDT KEY3	WDT KEY2	WDT KEY1	WDT KEY0

By default, the WDTC is read only. User needs to write values 1EH, 0E1H sequentially to the WDTKEY (97H) register to enable the WDTC write attribute, which is

```
MOV WDTKEY, # 01EH
MOV WDTKEY, # 0E1H
```

When WDTC is set, user need to write another values E1H, 1EH sequentially to the WDTKEY (97H) register to disable the WDTC write attribute, That is

```
MOV WDTKEY, # 0E1H
MOV WDTKEY, # 01EH
```

Watch Dog Timer Registers - WDT Control Register

WDTC (\$9F)

Bit7	Bit6	Bit5	Bit4	Bit3	Bit2	Bit1	Bit0
WDTE	Reserve	CLEAR	Unused	Unused	PS2	PS1	PS0

WDTE: Watch Dog Timer enable bit

CLEAR: Watch Dog Timer reset bit

If CLEAR bit set to 1, Watch Dog Timer will be reset. User don't reset value to 0 .

PS [2:0] : Overflow period select bits



PS2~PS0: clock sourer divider bit

PS [2:0]	Overflow Period (ms)
000	2.048
001	4.096
010	8.192
011	16.384
100	32.768
101	65.536
110	131.072
111	262.14

**Watch Dog Timer Register - System Control Register
SCONF (\$BFH)**

Bit7	Bit6	Bit5	Bit4	Bit3	Bit2	Bit1	Bit0
WDR	Unused	Unused	Unused	Unused	Reserved	Unused	ALEI

WDR: Watch Dog Timer Reset. When system reset by Watch Dog Timer overflow, WDR will be set to 1

ALEI: ALE output inhibit bit, to reduce EMI

Setting bit 0 (ALEI) of SCONF can inhibit the clock signal in Fosc/6Hz output to the ALE pin.

The bit 7 (WDR) of SCONF is Watch Dog Timer Reset bit. It will be set to 1 when reset signal generated by WDT overflow. User should check WDR bit whenever unpredicted reset happened.

Reduce EMI Function

The SM894051 allows user to reduce the EMI emission by setting 1 to the bit 0 (ALEI) of SCONF register. This function will inhibit the clock signal in Fosc/6Hz output to the ALE pin.

Application Reference

Valid for SM894051				
X'tal	3MHz	6MHz	9MHz	12MHz
C1	30 pF	30 pF	30 pF	30 pF
C2	30 pF	30 pF	30 pF	30 pF
R	open	open	open	open
X'tal	16MHz	25MHz	33MHz	40MHz
C1	30 pF	15 pF	5 pF	2 pF
C2	30 pF	15 pF	5 pF	2 pF
R	open	62K	6.8K	4.7K

Note : Oscillation circuit may differs with different crystal or ceramic resonator in higher oscillation frequency which was due to each crystal or ceramic resonator has its own characteristics. User should check with the crystal or ceramic resonator manufacture for appropriate value of external components.

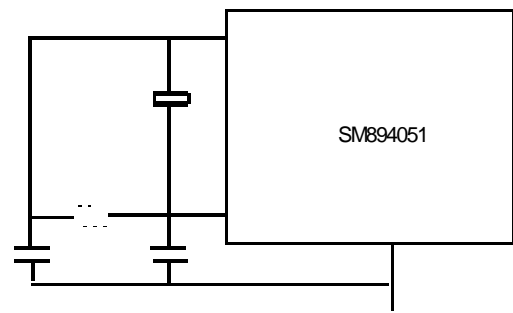



20L 300mil PDIP Information

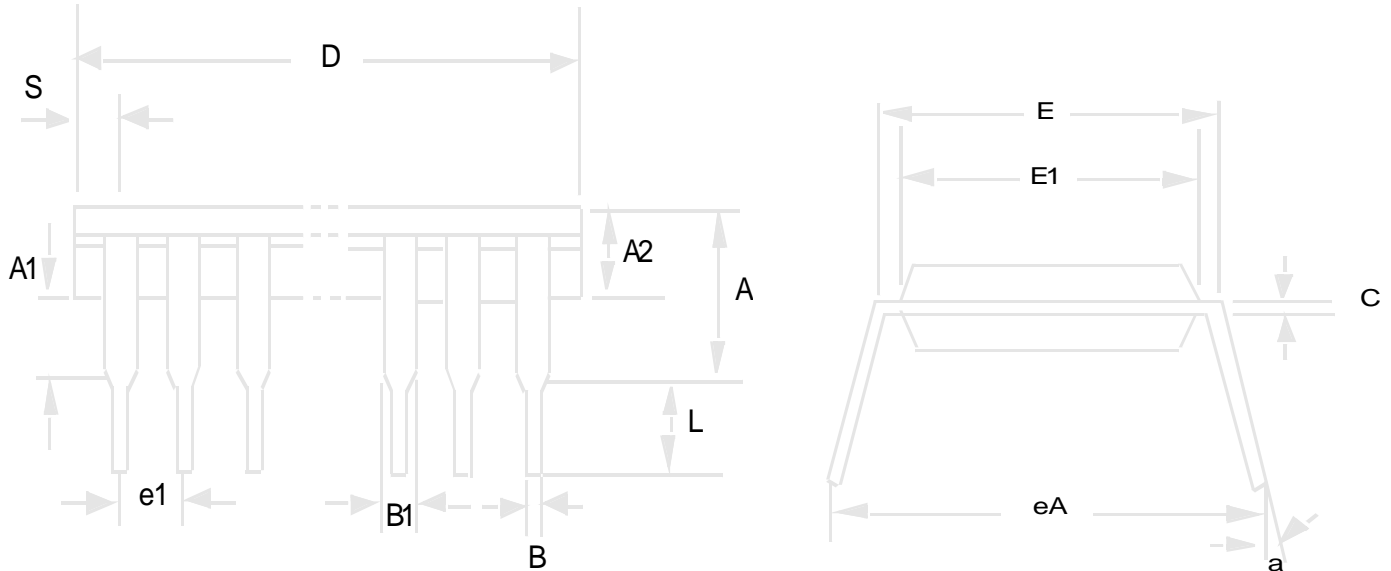

Note:

1. Dimension D Max & include mold flash or tie bar burrs.
2. Dimension E1 does not include inter lead flash.
3. Dimension D & E1 include mold mismatch and are determined at the mold parting line.
4. Dimension B1 does not include dam bar protrusion/infusion.
5. Controlling dimension is inch.
6. General appearance spec. should base on final visual inspection spec.

Symbol	Dimension in inch	
	Minimal / maximal	Minimal / maximal
A	- / 0.175	- / 4.45
A1	0.010 / -	0.25 / -
A2	0.125 / 0.135	3.18 / 3.43
B	0.016 / 0.022	0.41 / 0.58
B1	0.058 / 0.064	1.47 / 1.63
C	0.008 / 0.014	0.20 / 0.36
D	- / 1.040	- / 26.42
E	0.290 / 0.310	7.37 / 7.87
E1	0.245 / 0.255	6.22 / 6.48
e1	0.090 / 0.110	2.29 / 2.79
L	0.120 / 0.140	3.05 / 3.56
A	0°C / 15°C	0°C / 15°C
eA	0.335 / 0.375	8.51 / 9.53
S	- / 0.075	- / 1.91



20L 300mil SOIC Information

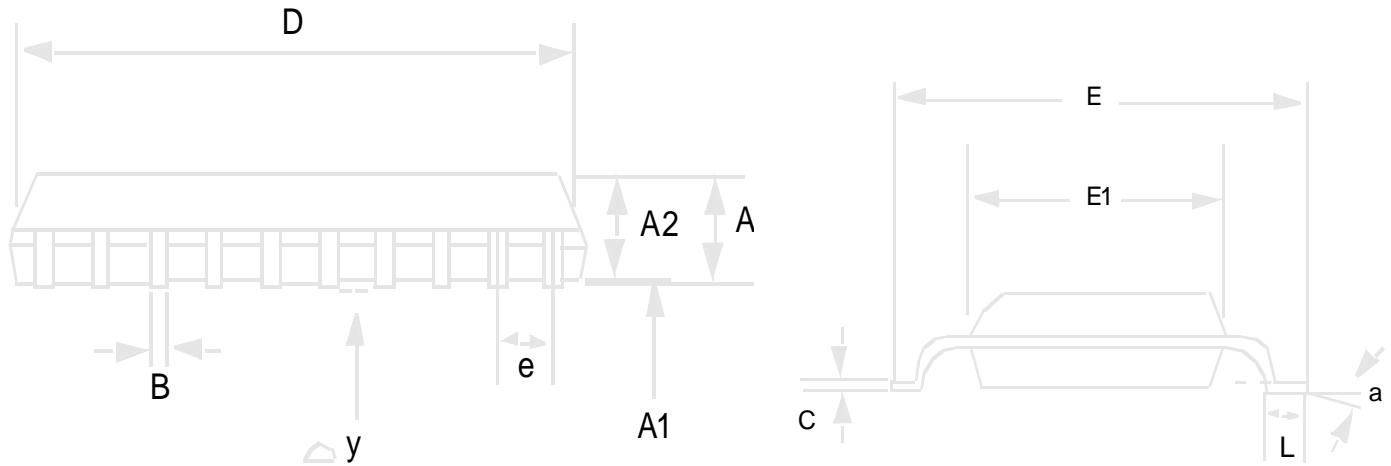

Note :

1. Controlling dimension : Inch
2. Lead frame material : Copper 194
3. After solocr plating lead thickness will be 0.015 MAX
4. Dimension 'D' does not include mold flash, protrusions or gate burrs
5. Dimension 'E' does not include inter-lead flash or protrusions
6. Tolerance: + 0.010 unless otherwise specified
7. Otherwise dimension follow acceptable spec

Symbol	Dimension in inch	
	Minimal / maximal	Minimal / maximal
A	0.093 / 0.104	2.36 / 2.64
A1	0.004 / 0.012	0.10 / 0.30
A2	- / -	- / -
B	0.013 / 0.020	0.33 / 0.51
C	0.007 / 0.011	0.18 / 0.28
D	0.496 / 0.508	12.60 / 12.9
E	0.394 / 0.419	0.01 / 10.64
E1	0.291 / 0.299	7.39 / 7.59
e1	- / -	- / -
L	0.015 / 0.050	0.38 / 1.27
y	- / 0.003	- / 0.076
a	0° / 8°	0° / 8°



eMCU Writer List		
Company	Contact information	Programmer Model Number
<u>SyncMOS</u> 4F, No.1,Creation Rd. 1, Science-Based Industrial Park, Hsinchu, Taiwan, ROC Web site: http://www.syncmos.com.tw	Tel:03-5783344-2190 Fax:03-5780493 E-mail: support@mail.syncmos.com.tw	MSM9169(1*1)