



ZEN ELECTRONIC

ZENESD®

TRANSIENT VOLTAGE SUPPRESSOR

PART NO. SM8S10A(CA)-SM8S43A(CA)



DESCRIPTION:

SM8S Series TVS diodes can be used in sensitive electronics protection against voltage transients induced by inductive load switching and lighting, especially for automotive load dump protection application.

FEATURES:

- Available in uni/bi-directional polarity.
- Low forward voltage drop & Low leakage current.
- High surge capability.
- Junction passivation optimized design passivated anisotropic rectifier technology.
- $T_J = 175\text{ }^\circ\text{C}$ capability suitable for high reliability and automotive requirement.
- Meets ISO7637-2 surge specification (varied by test condition).
- Meets MSL level 1, per J-STD-020, LF maximum peak of $245\text{ }^\circ\text{C}$.
- AEC-Q101 qualified.
- Compliant to ROHS Directive 2002/95/EC and in accordance to WEEE 2002/96/EC

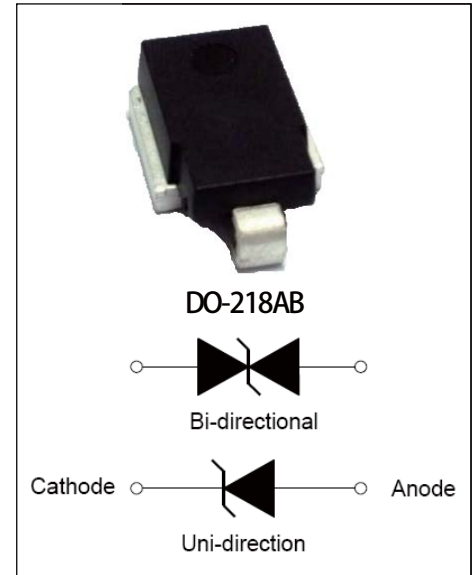

ABSOLUTE MAXIMUM RATINGS ($T_C=25\text{ }^\circ\text{C}$, RH=45%-75%, unless otherwise noted)

Parameter	Symbol	Value	Unit
Peak pulse power dissipation on 10/1000us waveform	P_{pp}	6600	Watts
Peak pulse power dissipation on 10/10000us waveform		5200	Watts
Peak pulse current with 10/1000us waveform	I_{pp}	See next table	Amps
Power dissipation on infinite heat S sink at $T_C=25\text{ }^\circ\text{C}$	P_D	8.0	Watts
Peak forward surge current, 8.3ms single half sine-wave	I_{FSM}	700	Amps
Operating Junction and Storage Temperature Range	T_J, T_{STG}	-55 to +150	$^\circ\text{C}$
Typical thermal resistance, junction to case	$R_{\theta C}$	0.9	$^\circ\text{C/Watt}$



ZEN ELECTRONIC

ZENESD®

TRANSIENT VOLTAGE SUPPRESSOR

PART NO. SM8S10A(CA)-SM8S43A(CA)



ELECTRICAL CHARACTERISTICS

Part Number		V_R	$I_R @ V_R$		$V_{BR} @ I_T$		I_T	$V_C @ I_{pp}$	I_{pp}
Uni-polar	Bi-polar	V	$\mu A @ 25^\circ C$	$\mu A @ 175^\circ C$	min(V)	max (V)	mA	V	A
SM8S 10A	SM8S 10CA	10.0	5	250	11.1	12.3	5	17.0	388
SM8S 11A	SM8S 11CA	11.0	5	150	12.2	13.5	5	18.2	363
SM8S 12A	SM8S 12CA	12.0	5	150	13.3	14.7	5	19.9	332
SM8S 13A	SM8S 13CA	13.0	5	150	14.4	15.9	5	21.5	307
SM8S 14A	SM8S 14CA	14.0	5	150	15.6	17.2	5	23.2	284
SM8S 15A	SM8S 15CA	15.0	5	150	16.7	18.5	5	24.4	270
SM8S 16A	SM8S 16CA	16.0	5	150	17.8	19.7	5	26.0	253
SM8S 17A	SM8S 17CA	17.0	5	150	18.9	20.9	5	27.6	239
SM8S 18A	SM8S 18CA	18.0	5	150	20.0	22.1	5	29.2	226
SM8S 20A	SM8S 20CA	20.0	5	150	22.2	24.5	5	32.4	204
SM8S 22A	SM8S 22CA	22.0	5	150	24.4	26.9	5	35.5	186
SM8S 24A	SM8S 24CA	24.0	5	150	26.7	29.5	5	38.9	170
SM8S 26A	SM8S 26CA	26.0	5	150	28.9	31.9	5	42.1	157
SM8S 28A	SM8S 28CA	28.0	5	150	31.1	34.4	5	45.4	145
SM8S 30A	SM8S 30CA	30.0	5	150	33.3	36.8	5	48.4	136
SM8S 32A	SM8S 32CA	32.0	5	150	35.5	39.4	5	51.4	128.5
SM8S 33A	SM8S 33CA	33.0	5	150	36.7	40.6	5	53.3	124
SM8S 36A	SM8S 36CA	36.0	5	150	40.0	44.2	5	58.1	114
SM8S 40A	SM8S 40CA	40.0	5	150	44.4	49.1	5	64.5	102
SM8S 43A	SM8S 43CA	43.0	5	150	47.8	52.8	5	69.4	95.1

Note:

①. For all types maximum $V_F = 1.8\text{ V}$ at $I_F = 100\text{ A}$ measured on 8.3 ms single half sine-wave or equivalent square wave, duty cycle = 4 pulses per minute maximum.

②. Surge waveform: 10/1000 μs

V_R : Stand-off Voltage -- Maximum voltage that can be applied

V_{BR} : Breakdown Voltage

V_C : Clamping Voltage -- Peak voltage measured across the suppressor at a specified I_{pp}

I_R : Reverse Leakage Current

I_T : Test current



ZEN ELECTRONIC

ZENESD®

TRANSIENT VOLTAGE SUPPRESSOR

PART NO. SM8S10A(CA)-SM8S43A(CA)



Mechanical Data

CASE: DO-218AB Molding compound meets UL 94V-0 flammability rating Base P/NHE3-ROHS-compliant, AEC-Q101 qualified.

Terminals: Matte tin plated leads, solder able per J-STD-002 and JESD 22-B102, HE3 suffix meets JESD 201 class 2 whisker tests.

ORDERING INFORMATION

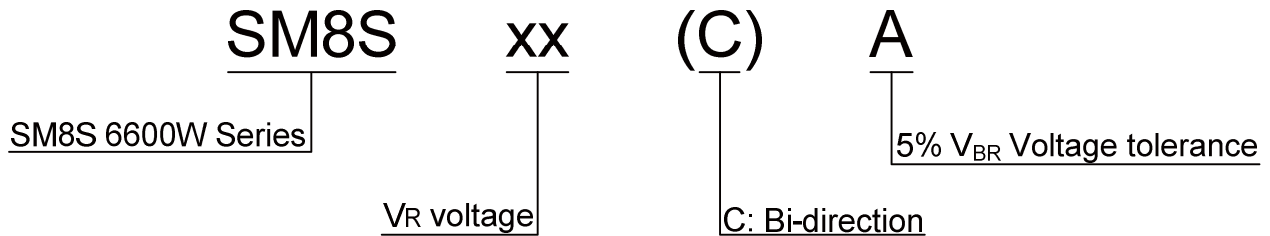

RATINGS AND CHARACTERISTICS CURVES ($T_A=25^{\circ}C$, unless otherwise noted)

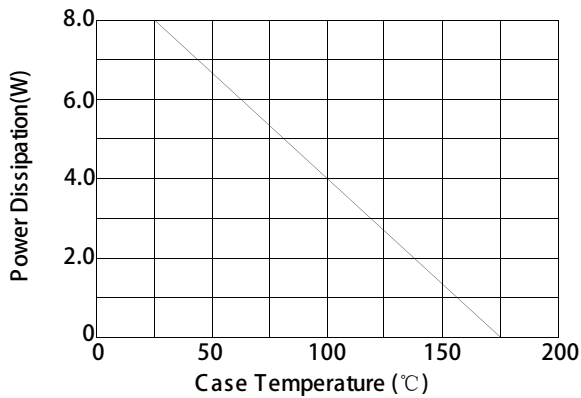

FIG.1: Power Derating Curve

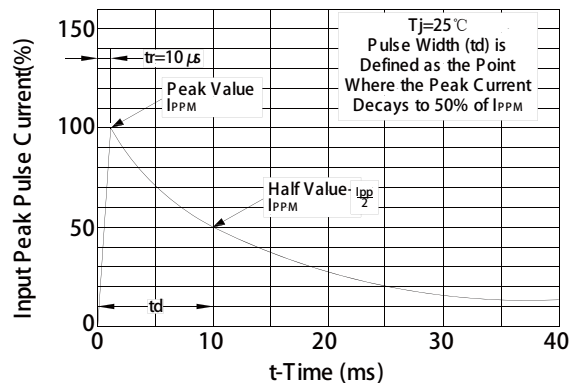

FIG.2: Pulse Waveform

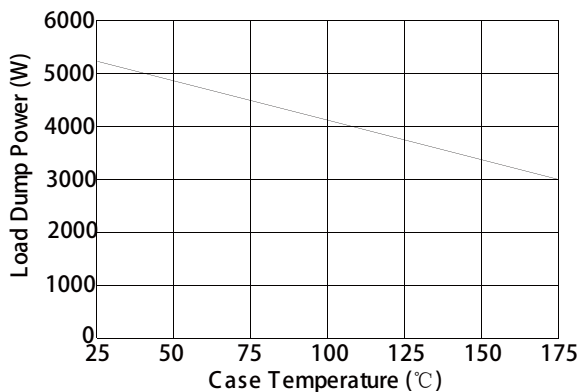

FIG.3: Load Dump Power Characteristics (10ms Exponential Waveform)

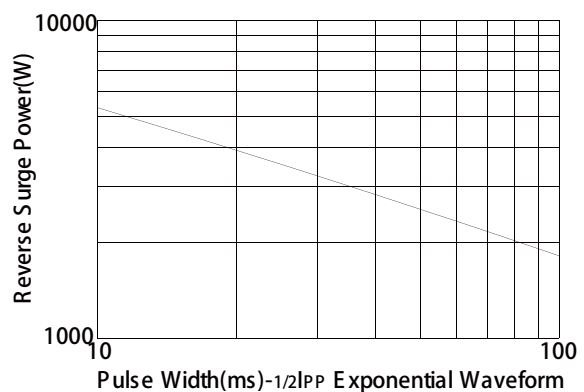

FIG.4: Reverse Power Capability



ZEN ELECTRONIC

ZENESD®

TRANSIENT VOLTAGE SUPPRESSOR

PART NO. SM8S10A(CA)-SM8S43A(CA)

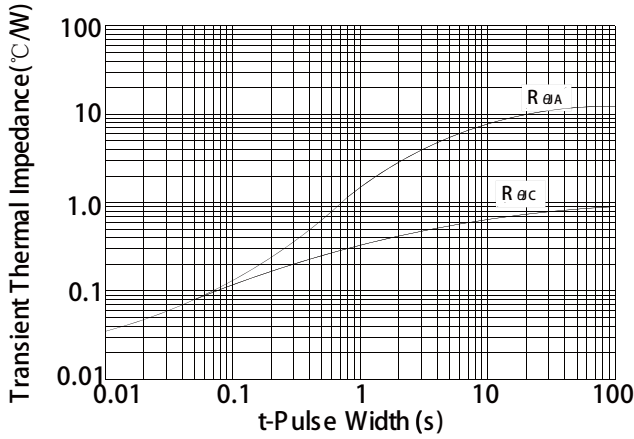

FIG.5: Typical Transient Thermal Impedance

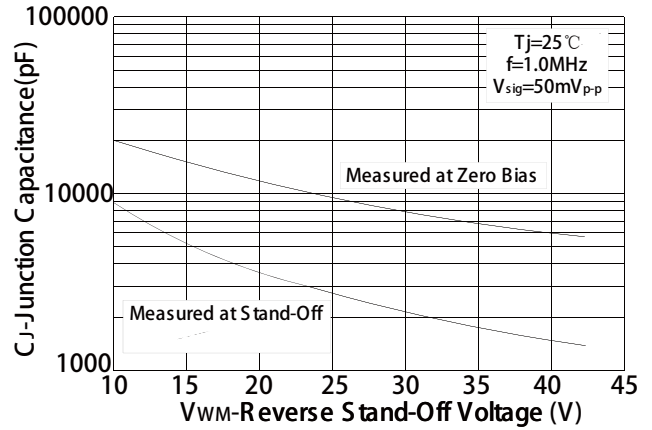
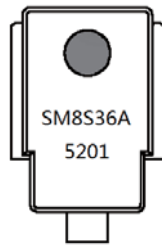

FIG.6: Typical Junction Capacitance

MARKING



SM8S36A: Part Number

5201: "5" --2015 (year)

"2" --2 (month)

"01" -- (lot)

SOLDERING PARAMETERS

Reflow Condition		Pb-Free assembly (see FIG.5)
Pre Heat	-Temperature Min ($T_{s(min)}$)	+150°C
	-Temperature Max($T_{s(max)}$)	+200°C
	-Time (Min to Max) (t_s)	60-180 secs.
Average ramp up rate (Liquid us Temp (T_L) to peak)		3°C/sec. Max
$T_{s(max)}$ to T_L - Ramp-up Rate		3°C/sec. Max
Reflow	-Temperature(T_L)(Liquid us)	+217°C
	-Temperature(t_L)	60-150 secs.
Peak Temp (T_p)		+260(+0/-5)°C
Time within 5°C of actual Peak Temp (t_p)		30 secs. Max
Ramp-down Rate		6°C/sec. Max
Time 25°C to Peak Temp (T_p)		8 min. Max
Do not exceed		+260°C

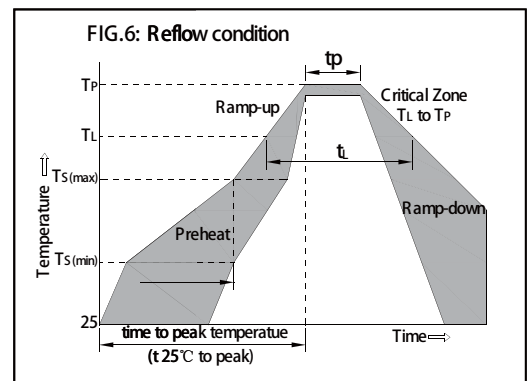



ZEN ELECTRONIC

ZENESD®

TRANSIENT VOLTAGE SUPPRESSOR

PART NO. SM8S10A(CA)-SM8S43A(CA)



PACKAGE MECHANICAL DATA

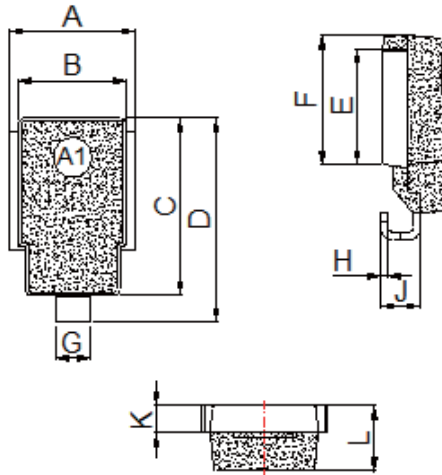

Dimension	Inches		Millimeters	
	Min	Max	Min	Max
A	0.374	0.413	9.5	10.5
B	0.327	0.342	8.3	8.7
C	0.524	0.539	13.3	13.7
D	0.592	0.628	15.0	16.0
E	0.335	0.358	8.5	9.1
F	0.374	0.398	9.5	10.1
G	0.094	0.118	2.4	3.0
H	0.020	0.028	0.5	0.7
J	0.106	0.146	2.7	3.7
K	0.075	0.083	1.9	2.1
L	0.185	0.201	4.7	5.1

TAPE AND REEL SPECIFICATION-DO-218AB

Spec No: _____

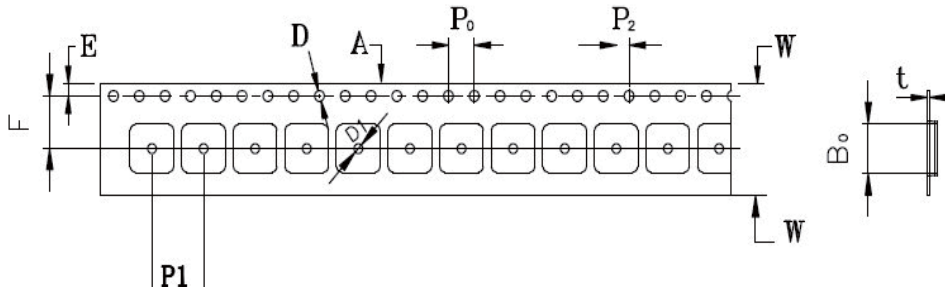

ITEM	W	A0	B0	K0	K1	P1	E	F	D	D1	P0	P2	T
DIM	24mm	10.8mm	16.13mm	5.21mm	3.9mm	16mm	1.75mm	11.5mm	1.55mm	1.55mm	4.0mm	2.0mm	0.4mm
TOL	±0.1	±0.1	±0.1	±0.1	±0.1	±0.1	±0.1	±0.1	±0.1	±0.1	±0.1	±0.1	±0.1

Note:

1. 10 pocket holes pitch cumulative tolerance ± 0.20 mm.
2. Carrier camber is 1mm in 100mm.
3. A0 and B0 are measured on a plane 0.30mm above the bottom of the pocket.
4. K0 is measured from a plane on the inside bottom of the pocket to the top surface of the pocket.
5. All dimensions meet EIA-481-2-A requirements.
6. Packing length per 22" Reel: 205Meters.



ZEN ELECTRONIC

ZENESD®

TRANSIENT VOLTAGE SUPPRESSOR

PART NO. SM8S10A(CA)-SM8S43A(CA)

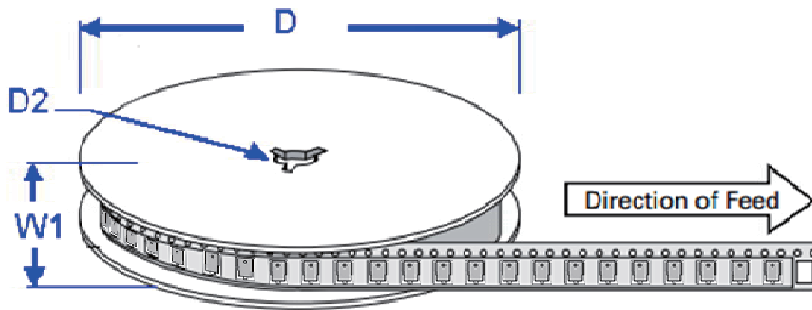

Dimensions	millimeters	inches
D	330 ± 0.2	13.0 ± 0.008
D2	13.2 ± 0.2	0.52 ± 0.008
W1	24 ± 0.2	0.94 ± 0.008

OUTLINE	REEL (PCS)	PER CARTON (PCS)	REEL DIAMETERS (mm)
TAPING	750	3000	330