

OVERVIEW

The SM9403BM is a DVDROM and DVDROM servo preprocessor LSI, designed for double-speed format DVDROM and DVDROM drives.

The SM9403BM is fabricated using a BiCMOS process, and incorporates an analog signal processing circuit that generates signals needed by the digital servo processor, a DPD signal processing circuit (DVDROM), and a CAPA (Complementary Allocated Pit Address) detection circuit (DVDROM) all in a single chip. It operates from a single 5 V supply, and is available in 36-pin plastic SSOP packages.

FEATURES

- DPD signal processor
- Tracking error signal output
- Focus error signal output
- Tracking error signal sample-and-hold
- Focus error signal sample-and-hold
- CAPA detection function
- Track count pulse generator
- Off-track detection
- 2V and 4V reference voltage generator
- Serial interface for setting internal parameters
- Sleep-mode function
- Single 5 V supply
- 36-pin plastic SSOP

APPLICATIONS

- Double-speed DVDROM drives
- Double-speed DVDROM drives

ORDERING INFORMATION

Device	Package
SM9403BM	36-pin SSOP

PINOUT

36-pin SSOP (Top View)

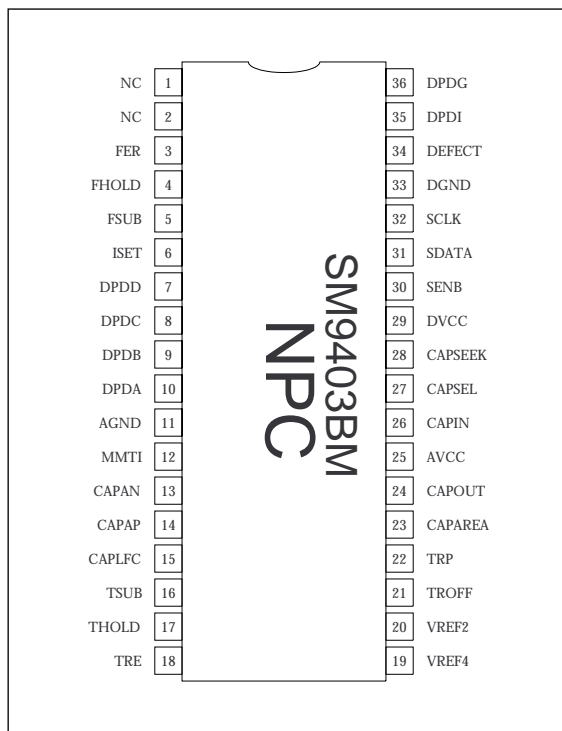

PACKAGE DIMENSIONS

(Unit: mm)

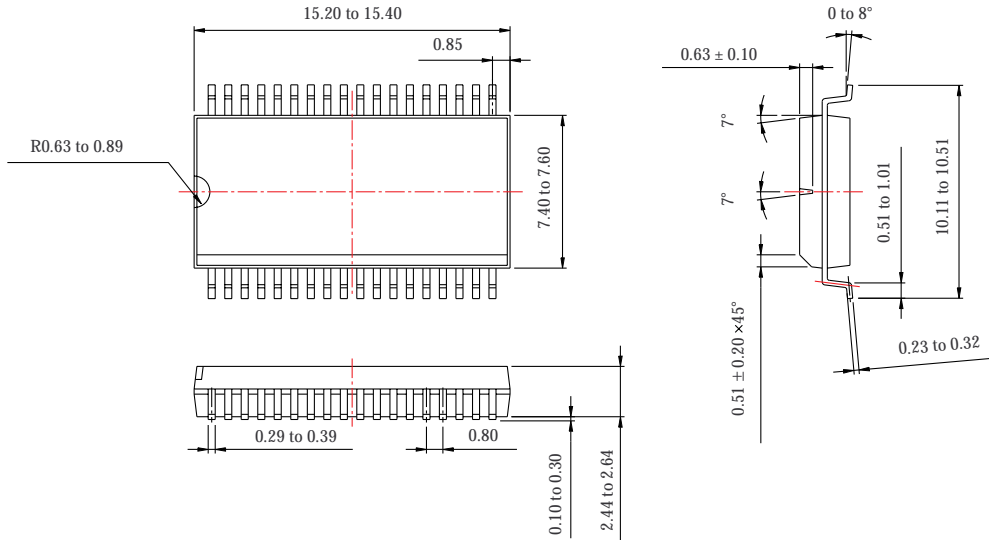

BLOCK DIAGRAM

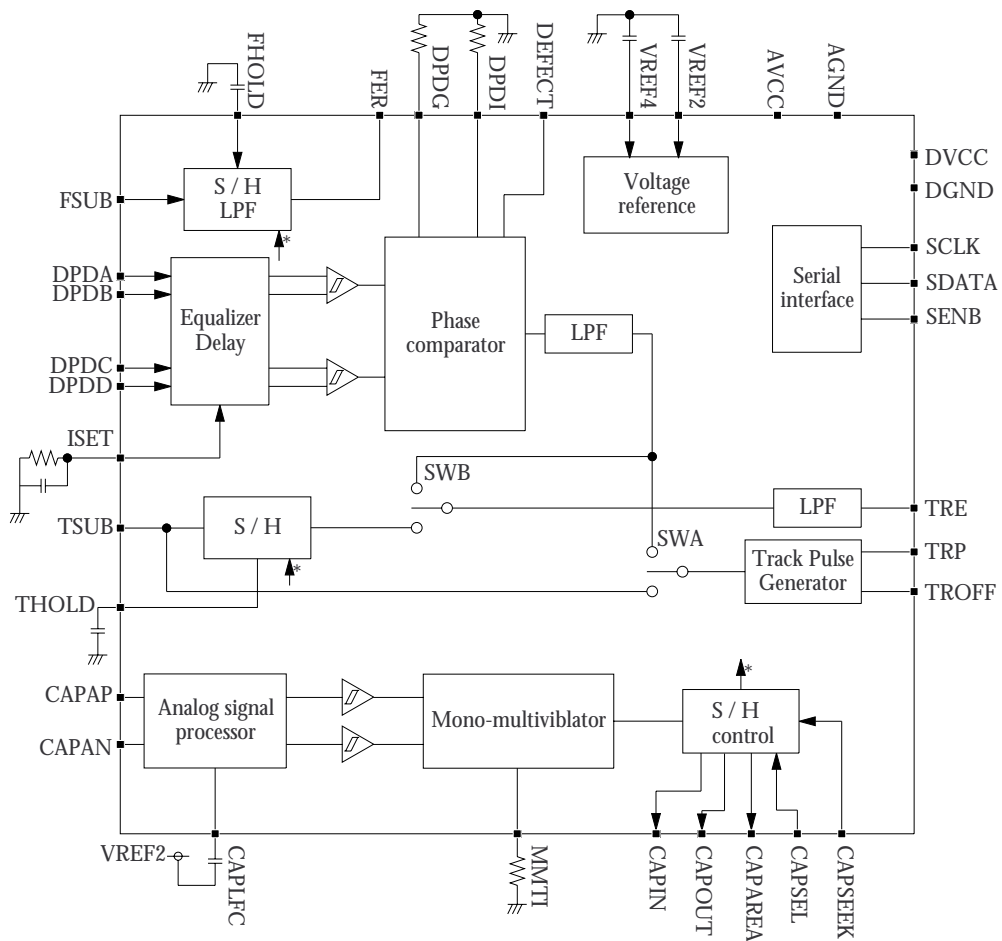

PIN DESCRIPTION

Number	Name	I/O ¹	Function
1	NC	O	No connection
2	NC	O	No connection
3	FER	O	Focus error signal output
4	FHOLD	-	Focus error hold capacitor connection
5	FSUB	I	Focus error signal input
6	ISET	I	DPD signal equalizer, reference current set resistor connection
7	DPDD	I	DPD signal input D
8	DPDC	I	DPD signal input C
9	DPDB	I	DPD signal input B
10	DPDA	I	DPD signal input A
11	AGND	-	Analog circuit ground
12	MMTI	I	Mono-multivibrator time-constant set resistor connection
13	CAPAN	I	ID data signal differential inverting input
14	CAPAP	I	ID data signal differential non-inverting input
15	CAPLFC	-	Slice-level detect capacitor connection
16	TSUB	I	Tracking error signal input
17	THOLD	-	Tracking error hold capacitor connection
18	TRE	O	Tracking error signal output
19	VREF4	O	4V reference voltage output
20	VREF2	O	2V reference voltage output
21	TROFF	O	Off-track detect signal output. LOW when off-track.
22	TRP	O	Track count pulse output. HIGH-level pulse for land to outer tracking.
23	CAPAREA	O	ID interval detect signal output. ID interval detected when HIGH.
24	CAPOUT	O	Outer offset ID detect signal output. Outer offset ID interval detected when HIGH.
25	AVCC	-	Analog circuit power supply
26	CAPIN	O	Inner offset ID detect signal output. Inner offset ID interval detected when HIGH.
27	CAPSEL	lpd	ID interval signal input. ID interval selected when HIGH.
28	CAPSEEK	lpd	Seek operation signal input. Seek operation selected when HIGH.
29	DVCC	-	Logic circuit power supply
30	SENB	I	Serial interface enable input. Enabled when HIGH.
31	SDATA	I/O	Serial interface data input/acknowledge output
32	SCLK	I	Serial interface clock input
33	DGND	-	Logic circuit ground
34	DEFECT	lpd	Defect position signal input. Defect position indicated when HIGH.
35	DPDI	I	DPD signal hold delay set resistor connection
36	DPDG	I	DPD signal phase difference to voltage converter coefficient set resistor connection

1. I = input, lpd = Input with built-in pull-down resistor, I/O = input/output (N-channel open-drain when output), O = output

SPECIFICATIONS

Absolute Maximum Ratings

GND = 0 V

Parameter	Symbol	Condition	Rating	Unit
Supply voltage range	V_{CC}		-0.5 to 7.0	V
Input voltage range	V_{IN}		-0.5 to $V_{CC} + 0.5$	V
Operating temperature range	T_{opr}		0 to 70	°C
Storage temperature range	T_{stg}		-40 to 125	°C
Power dissipation	P_D		250	mW
Soldering temperature	T_{sld}		260	°C
Soldering time	t_{sld}		10	s

Recommended Operating Conditions

GND = 0 V

Parameter	Symbol	Condition	Rating	Unit
Specifications supply voltage range	V_{CC}		4.75 to 5.25	V
Operating supply voltage range	V_{CC}		4.5 to 5.5	V
Operating temperature range	T_{opr}		0 to 70	°C

Recommended External Components

Pin No.	Pin name	Component	Tolerance
4	FHOLD	1000pF capacitor	K ($\pm 10\%$)
6	ISET	47k Ω resistor	$\pm 1\%$
		0.01 μ F capacitor	Z (+80% to -20%)
12	MMT1	120k Ω resistor	$\pm 1\%$
15	CAPLFC	0.01 μ F capacitor	Z (+80% to -20%)
17	THOLD	1000pF capacitor	K ($\pm 10\%$)
19	VREF4	0.1 μ F capacitor	Z (+80% to -20%)
20	VREF2	0.1 μ F capacitor	Z (+80% to -20%)
35	DPDI	47k Ω resistor	$\pm 1\%$
36	DPDG	33k Ω resistor	$\pm 1\%$

DC Electrical Characteristics

$V_{CC} = 5V \pm 5\%$, $GND = 0V$, $T_a = 0$ to $70^\circ C$

Parameter	Symbol	Condition	Rating			Unit
			min	typ	max	
Current consumption ¹	I_{CC1}	Operating mode	-	28	34	mA
	I_{CC2}	Sleep mode 1	-	17	21	
	I_{CC3}	Sleep mode 2	-	2.0	2.6	
	I_{CC4}	Sleep mode 3	-	-	1.0	
	ΔI_{CC}	$I_{CC1} - I_{CC2}$	9	-	-	
CAPSEEK, CAPSEL, DEFECT, SENB, SDATA, SCLK HIGH-level input voltage	V_{IH}		$0.8V_{CC}$	-	-	V
CAPSEEK, CAPSEL, DEFECT, SENB, SDATA, SCLK LOW-level input voltage	V_{IL}		-	-	$0.2V_{CC}$	V
CAPSEEK, CAPSEL, DEFECT HIGH-level input current	I_{IH1}	$V_{IN} = V_{CC}$	50	100	200	μA
SENB, SDATA, SCLK HIGH-level input current	I_{IH2}	$V_{IN} = V_{CC}$	-	-	3	μA
CAPSEEK, CAPSEL, DEFECT, SENB, SDATA, SCLK LOW-level input current	I_{IL}	$V_{IN} = GND$	-3	-	-	μA
CAPAREA, CAPIN, CAPOUT, TRP, TROFF HIGH-level output voltage	V_{OH}	$I_{OH} = -0.2mA$	$V_{CC} - 0.2$	-	-	V
CAPAREA, CAPIN, CAPOUT, TRP, TROFF LOW-level output voltage	V_{OL1}	$I_{OL} = 0.8mA$	-	-	0.4	V
SDATA LOW-level output voltage	V_{OL2}	$I_{OL} = 7mA$	-	-	1.0	V

1. 33k Ω resistor connected between DPDG and AGND
 120k Ω resistor connected between MMT1 and AGND
 1000pF capacitor connected between F_HOLD and AGND
 0.1 μF capacitor connected between VREF4 and AGND
 0.01 μF capacitor connected between CAPLFC and AGND
 CAPAP, CAPAN, DPDA, DPDB, DPDC, DPDD, FSUB, TSUB connected to VREF2 or other 2V supply.
 SENB, SDATA, SCLK connected to GND; All other pins (excluding supply and ground pins) open circuit.
 Sleep mode 1: DPD system only in sleep condition.
 Sleep mode 2: All blocks except reference supply voltage generator in sleep condition.
 Sleep mode 3: All blocks in sleep condition.
- 47k Ω resistor connected between DPDI and AGND
 47k Ω resistor connected between ISET and AGND
 1000pF capacitor connected between THOLD and AGND
 0.1 μF capacitor connected between VREF2 and AGND
 0.01 μF capacitor connected between ISET and AGND

Focus Sample-and-Hold, Low-pass Filter Characteristics (FSUB → FER)

$V_{CC} = 5V \pm 5\%$, $GND = 0V$, $T_a = 0$ to 70°C , FSUB and FER signals in phase

Parameter	Condition	Rating			Unit	
		min	typ	max		
FSUB input signal range	VREF2 reference	-1.25	0	+1.25	V	
FER output voltage range	VREF2 reference	-1.25	0	+1.25	V	
FER output offset voltage	VREF2 reference, $V_{IN} = V_{REF2}$	-	-	± 8.0	mV	
FER output offset voltage temperature drift	VREF2 reference	-	-	± 45	$\mu\text{V}/^\circ\text{C}$	
FER output signal slew rate	LPF off	1	-	-	V/ μs	
FER output load regulation	$I_{OUT} = \pm 3\text{mA}$, $V_{IN} = V_{REF2}$	-	-	± 10	mV	
FSUB input impedance		100	-	-	k Ω	
FER output signal gain		-0.17	0	+0.17	dB	
FER output signal bandwidth ¹	$V_{IN} = 1.5\text{Vp-p}$, -3dB from DC	LPF off (FFE = HIGH)	500	-	-	kHz
		LPF on (FFE = LOW)	115	160	230	
FER output gain peaking ¹	DC to -3dB frequency	-3	-	+0.5	dB	
Hold time FER output droop characteristic	$V_{IN} = 200\text{mVp-p}$, $C_{\text{HOLD}} = 1000\text{pF}$	-	-	0.025	%/ μs	
S/H acquisition time	$\Delta V_{IN} = 200\text{mV}$, target value $\pm 10\%$	-	-	1	μs	
FER output hold error	With respect to the previous value	-	-	± 4	mV	
Power-down state FER output impedance		1	-	-	M Ω	

1. $C_L = 20\text{pF}$, $R_L = 500\Omega$

Tracking Sample-and-Hold, Low-pass Filter Characteristics (TSUB → TRE)

$V_{CC} = 5V \pm 5\%$, $GND = 0V$, $T_a = 0$ to 70°C , TSUB and TRE signals in phase

Parameter	Condition	Rating			Unit	
		min	typ	max		
TSUB input signal range	VREF2 reference	-1.25	0	+1.25	V	
TRE output voltage range	VREF2 reference	-1.25	0	+1.25	V	
TRE output offset voltage	VREF2 reference, $V_{IN} = V_{REF2}$	-	-	± 8.0	mV	
TRE output offset voltage temperature drift	VREF2 reference	-	-	± 45	$\mu\text{V}/^\circ\text{C}$	
TRE output load regulation	$I_{OUT} = \pm 3\text{mA}$, $V_{IN} = V_{REF2}$	-	-	± 10	mV	
TSUB input impedance		100	-	-	k Ω	
TRE output signal gain		-0.17	0	+0.17	dB	
TRE output signal bandwidth ¹	$V_{IN} = 1.5\text{Vp-p}$, -3dB from DC	TFE = HIGH	24	35	50	kHz
		TFE = LOW	115	160	230	
TRE output gain peaking ¹	DC to -3dB frequency	-3	-	+0.5	dB	
Hold time TRE output droop characteristic	$V_{IN} = 200\text{mVp-p}$, $C_{\text{HOLD}} = 1000\text{pF}$	-	-	0.025	%/ μs	
S/H acquisition time	$\Delta V_{IN} = 200\text{mV}$, target value $\pm 10\%$	-	-	1	μs	
TRE output hold error	With respect to the previous value	-	-	± 4	mV	
Power-down state TRE output impedance		1	-	-	M Ω	

1. $C_L = 20\text{pF}$, $R_L = 500\Omega$

DPD Error Signal Detector Characteristics (DPDA/DPDB/DPDC/DPDD → TRP)

$V_{CC} = 5V \pm 5\%$, $GND = 0V$, $T_a = 0$ to $70^\circ C$

Parameter ¹	Condition		Rating			Unit
			min	typ	max	
DPDA/DPDB/DPDC/DPDD input voltage range	VREF2 reference		-0.55	-	+1	V
DPDA/DPDB/DPDC/DPDD input impedance			1	-	-	MΩ
Signal gain relative accuracy	Gain relative to DPDA, DPDB, DPDC, DPDD inputs		-	-	±0.17	dB
Equalizer gain	1MHz setting	DG2 = LOW	1.2	1.6	2.3	dB
		DG2 = HIGH	1.8	2.2	2.9	
	5MHz setting	DG2 = LOW	5.5	6.1	6.6	
		DG2 = HIGH	6.1	6.7	7.2	
Equalizer frequency response	Peak gain frequency (EQE = HIGH)		3.75	5.0	6.25	MHz
	-3dB frequency (EQE = LOW)		11	22	33	
Equalizer frequency response relative accuracy	f_{peak} , (A + C) vs. (B + D)		-	-	±1.5	%
AC coupling time circuit -3dB frequency	Time constant 1	DG2 = LOW	56	84	109	kHz
	Time constant 2	DG2 = HIGH	17	24	32	
AC coupling time constant relative accuracy	-3dB frequency, (A + C) vs. (B + D)		-	-	±2	%
Delay control range	See table 4.		See table 4.			ns
Phase difference detector minimum time	DG1 = DG2 = LOW		2	-	-	ns
Phase difference detector maximum time	DG1 = DG2 = HIGH		-	-	1	μs
Phase difference detector minimum repeat time	Input pulse interval		120	-	-	ns
Phase difference to voltage conversion coefficient	DG1 = DG2 = LOW		-	See table 5.	typ ± 20%	mV/ns
Phase difference to voltage conversion coefficient change accuracy			-	See table 8.	±1	dB
Phase difference output offset voltage	VREF2 reference		-	-	±0.1	V
Phase difference output offset voltage temperature drift	VREF2 reference		-	-	±570	μV/°C
DEFECT signal response time			-	-	1	μs
DPD enable response time	DPE flag		-	-	2	μs
Abnormal waveform TRP droop characteristic	$V_{OUT} = V_{REF2} \pm 200mV$, VREF2 reference		-	-	0.1	%/μs
TRP output voltage range	VREF2 reference		-1.25	0	+1.25	V
TRP output signal frequency response	-3dB frequency		500	-	-	kHz

1. The tracking error signal TRE is positive with respect to VREF2 if the (DPDA + DPDC) signal phase difference is leading.

The detected phase difference is the difference between the point when one internal comparator output changes (from CMA and CMB both HIGH or both LOW) until the second output changes before the first changes again. The phase difference is converted to a voltage and sampled for output. Other signals are held constant in the output stage when a phase difference is detected.

Header Position Detector Characteristics (CAPAP/N → CAPAREA, CAPIN, CAPOUT) $V_{CC} = 5V \pm 5\%$, $GND = 0V$, $T_a = 0$ to 70°C

Parameter	Condition	Rating			Unit
		min	typ	max	
CAPAP/N input voltage range		1	-	3	V
Analog signal processor frequency response	$V_{IN} = V_{REF2} \pm 0.5V$, -3dB from DC	13	-	-	MHz
Analog signal quantization slice level		-	See table 9.	typ $\pm 15\%$	V
Mono-multivibrator time constant		typ - 5%	See table 10.	typ + 45%	μs
Mono-multivibrator time constant switching accuracy		-	-	± 5	%
Mono-multivibrator time-constant block interval accuracy		-	-	± 2.5	%
CAPIN, CAPOUT, CAPAREA output rise time and fall time	$C_L = 20\text{pF}$	-	-	15	ns

Sample-and-Hold Control Signal Generator Characteristics $V_{CC} = 5V \pm 5\%$, $GND = 0V$, $T_a = 0$ to 70°C

Parameter	Condition	Rating			Unit
		min	typ	max	
FER, TRE output response time ¹	Mono-multivibrator/CAPSEL/CAPSEEK → FSHCNT/TSHCNT	-	-	100	ns
	Serial interface (HRE, FHE, THE, HAE) → FSHCNT/TSHCNT	-	-	2	μs

1. FSHCNT and TSHCNT are the focus and tracking sample-and-hold internal control signals, respectively.

Tracking Error Signal Switching Characteristics (SWA, SWB) $V_{CC} = 5V \pm 5\%$, $GND = 0V$, $T_a = 0$ to 70°C

Parameter	Condition	Rating			Unit
		min	typ	max	
Switching response time	Serial interface timing	-	-	1	μs

Track Count Pulse Generator Characteristics (TSUB → TRP, TROFF)

$V_{CC} = 5V \pm 5\%$, $GND = 0V$, $T_a = 0$ to $70^\circ C$

Parameter	Condition	Rating			Unit
		min	typ	max	
TSUB input signal range	VREF2 reference	-1.25	-	+1.25	V
TSUB signal limiter voltage level	VREF2 reference	± 1.0	-	-	V
TSUB signal amplifier gain	$f = 5kHz$	5.83	6.0	6.17	dB
Quantization level offset set value		typ - 15%	See table 15	typ + 15%	mV
TRP output comparator hysteresis ¹		typ - 10%	See table 16	typ + 10%	mV
TRP output comparator hysteresis response time	Minimum hysteresis, target value $\pm 10\%$	-	-	600	ns
TRP output comparator hysteresis switching response time	Minimum \leftrightarrow maximum hysteresis value	-	-	2	μs
TROFF output comparator window		typ - 10%	See table 17	typ + 10%	mV
TROFF output comparator window switching response time	Minimum \leftrightarrow maximum window value	-	-	5	μs

1. TRP has the same polarity as TRE (i.e. TRP is HIGH when TRE > VREF2).
TROFF is HIGH when the input signal is inside the window, and LOW when outside the window.

Reference Voltage Generator Characteristics (VREF2, VREF4)

$V_{CC} = 5V \pm 5\%$, $GND = 0V$, $T_a = 0$ to $70^\circ C$

Parameter	Condition	Rating			Unit	
		min	typ	max		
VREF4 output voltage	$V_{CC} = 5V, T_a = 25^\circ C, I_{OUT} = 0$	3.84	4.0	4.16	V	
VREF2 output voltage		1.92	2.0	2.08	V	
VREF4 output voltage temperature drift	$V_{CC} = 5V, T_a = 0$ to $70^\circ C, I_{OUT} = 0$	-	-	± 400	$\mu V/^\circ C$	
VREF2 output voltage temperature drift		-	-	± 200	$\mu V/^\circ C$	
VREF4 output voltage supply voltage dependency	$V_{CC} = 5V \pm 5\%, T_a = 25^\circ C, I_{OUT} = 0$	-	-	± 6	mV	
VREF2 output voltage supply voltage dependency		-	-	± 3	mV	
VREF4 output voltage load regulation	$V_{CC} = 5V,$ $T_a = 25^\circ C$	$I_{OUT} = 0$ to 8mA	-	-	-20	mV
VREF2 output voltage load regulation	$T_a = 25^\circ C$	$I_{OUT} = 0$ to $\pm 5mA$	-	-	± 10	mV
Relative output voltage accuracy ¹	$V_{CC} = 5V, I_{OUT} = 0$	-	-	± 20	mV	
Relative output voltage temperature drift	$V_{CC} = 5V, T_a = 0$ to $70^\circ C, I_{OUT} = 0$	-	-	± 10	$\mu V/^\circ C$	
Relative output-voltage supply-voltage dependency	$V_{CC} = 5V \pm 5\%, T_a = 25^\circ C, I_{OUT} = 0$	-	-	± 1	mV	
VREF4 power-down output impedance		13	-	-	k Ω	
VREF2 power-down output impedance		1	-	-	M Ω	

1. Defined as $(VREF2 - (VREF4 \div 2))$.

Serial Interface Characteristics (SCLK, SDATA, SENB)

$V_{CC} = 5V \pm 5\%$, $GND = 0V$, $T_a = 0$ to $70^\circ C$

Parameter	Symbol	Condition	Rating			Unit
			min	typ	max	
SCLK pulse cycle	t_{cySCK}		100	-	-	ns
SCLK HIGH-level pulsewidth	t_{whSCK}		40	-	-	ns
SCLK LOW-level pulsewidth	t_{wlSCK}		40	-	-	ns
SENB setup time	t_{sSEN}		20	-	-	ns
SENB hold time	t_{hSEN}		40	-	-	ns
SDATA setup time	t_{sSDA}		15	-	-	ns
SDATA hold time	t_{hSDA}		15	-	-	ns
ACK setup time ¹	t_{sACK}		0	-	20	ns
ACK hold time ¹	t_{hACK}		-	-	50	ns
SENB interval	t_{inSEN}		100	-	-	ns

1. ACK is the acknowledge output (n-channel open-drain). LOW-level output when the data received is valid.
SDATA load capacitance is 15pF.

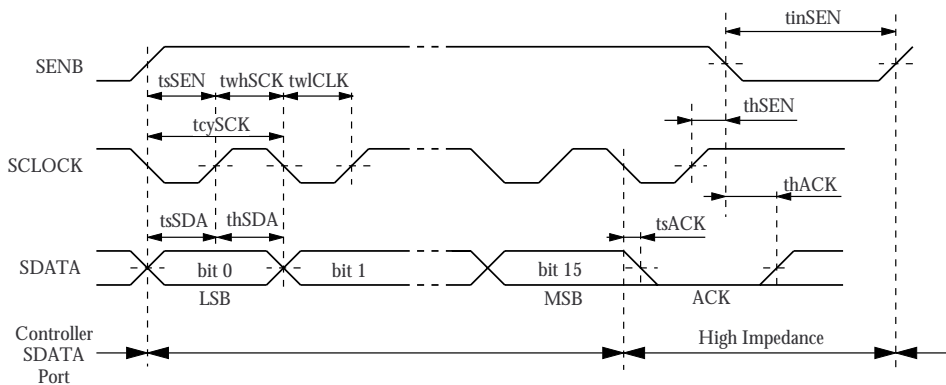

FUNCTIONAL DESCRIPTION

Serial Interface

The SM9403BM uses a serial interface comprising 5 ports to control and set all functions. The address and bit configuration of each port is shown in table 1

Table 1. Port address and bit configuration¹

Bit number															
15	14	13	12	11	10	9	8	7	6	5	4	3	2	1	0
Data								Address							
MSB															LSB
DPE	HAE	FFE	TFE	SWB	SWA	SL2	SL1	×	LOW	LOW	LOW	HIGH	LOW	×	×
OF3	OF2	OF1	WD2	WD1	HS3	HS2	HS1	×	LOW	LOW	LOW	HIGH	HIGH	×	×
THE	FHE	HRE	MM2	MM1	LS3	LS2	LS1	×	LOW	LOW	HIGH	LOW	LOW	×	×
EQE	CG3	CG2	CG1	DL4	DL3	DL2	DL1	×	LOW	LOW	HIGH	LOW	HIGH	×	×
TS3	TS2	TS1	-	-	-	DG2	DG1	×	LOW	LOW	HIGH	HIGH	LOW	×	×

1. × = don't care, - = unassigned

Serial data is input on SDATA with the LSB first, in sync with the falling edge of the SCLK clock. After the 16th SCLK falling edge and 16 bits of valid data has been input, the SDATA n-channel open-drain output goes LOW as an acknowledge signal.

If the number of SCLK cycles which occur when SENB (serial interface enable) is HIGH is less than

16, the received data is ignored and the internal port is not updated. If the number of SCLK cycles is greater than 16, the data is still considered value up to the 16th SCLK falling edge, the data is latched into the internal port, and the acknowledge signal is output. The acknowledge signal is held until SENB goes LOW again.

Focus Sample-and-Hold/Low-pass Filter (FSUB → FER)

This stage, the signal which is generated from the header position detector signal samples and holds the focus error signal. The output then passes through a low-pass filter. This low-pass filter can be turned ON or OFF using the serial interface control bit FFE.

Table 2. Focus low-pass filter ON/OFF control

FFE	Low-pass filter ¹
LOW	ON
HIGH	OFF

1. Default is ON

Tracking Sample-and-Hold/Low-pass Filter (TSUB → TRE)

This stage, the signal which is generated from the header position detector signal samples and holds the tracking error signal. The output then passes through a low-pass filter. This low-pass filter cutoff frequency can be switched using the serial interface control bit TFE.

Table 3. Tracking low-pass filter cutoff frequency

TFE	Low-pass filter ¹
LOW	$f_c = 160\text{kHz}$
HIGH	$f_c = 35\text{kHz}$

1. Default is 160kHz

DPD Error Signal Detector (DPDA/DPDB/DPDC/DPDD → TRP)

This stage compares the DPD signals, passes the comparator output through a low-pass filter to obtain the DPD tracking error signal.

The DPD signals are first added, (DPDA + DPDC) and (DPDB + DPDD), then passed to an equalizer. A relative time delay is added for offset correction. The signals are then converted to a pulse waveform by comparators with hysteresis characteristics.

The phase comparator then compares the phase of the pulse waveforms to obtain a time signal equivalent to the tracking error. The time signal is then converted to a voltage.

The converted voltage is passed to the output stage, undergoes sampling timing compensation before being integrated to generate the tracking error signal output.

The phase comparator incorporates a detector function which prevents abnormal waveform signals getting to the output by holding the output constant.

In addition, serial interface control bit DPE and input DEFECT can be used to force the tracking error signal to the reference voltage VREF2. These controls can be used when powering up a system or to prevent output saturation from occurring during periods when the input signal is unstable.

The relative time delay setting and time-to-voltage conversion coefficient can be controlled using serial interface control bits. Also, the equalizer used to compensate for the previous stage can be turned ON or OFF using serial interface control.

Table 4. DPD delay time settings

DG2	DG1	DL4	DL3	DL2	DL1	DPD delay (ns) ¹		
						min	typ	max
LOW	LOW	LOW	LOW	LOW	LOW	0	0	0
		LOW	LOW	LOW	HIGH	-2.2	-3.0	-3.3
		LOW	LOW	HIGH	LOW	-4.2	-5.6	-6.4
		LOW	LOW	HIGH	HIGH	-6.0	-8.0	-9.5
		LOW	HIGH	LOW	LOW	-7.5	-11	-13
		LOW	HIGH	LOW	HIGH	-10	-14	-16
		LOW	HIGH	HIGH	LOW	-12	-17	-20
		LOW	HIGH	HIGH	HIGH	-14	-20	-24
		HIGH	LOW	LOW	LOW	+17	+24	+29
		HIGH	LOW	LOW	HIGH	+14	+20	+23
		HIGH	LOW	HIGH	LOW	+12	+17	+19
		HIGH	LOW	HIGH	HIGH	+10	+13	+15
		HIGH	HIGH	LOW	LOW	+7.5	+11	+13
		HIGH	HIGH	LOW	HIGH	+5.6	+7.7	+9.0
		HIGH	HIGH	HIGH	LOW	+3.7	+5.5	+6.2
		HIGH	HIGH	HIGH	HIGH	+2.0	+3.0	+3.4
LOW	HIGH	LOW	LOW	LOW	LOW	0	0	0
		LOW	LOW	LOW	HIGH	-3.8	-4.5	-6.0
		LOW	LOW	HIGH	LOW	-7.0	-8.5	-11
		LOW	LOW	HIGH	HIGH	-11	-13	-17
		LOW	HIGH	LOW	LOW	-16	-18	-24
		LOW	HIGH	LOW	HIGH	-20	-23	-32
		LOW	HIGH	HIGH	LOW	-26	-30	-42
		LOW	HIGH	HIGH	HIGH	-34	-38	-55
		HIGH	LOW	LOW	LOW	+44	+49	+74
		HIGH	LOW	LOW	HIGH	+33	+37	+52
		HIGH	LOW	HIGH	LOW	+25	+29	+38
		HIGH	LOW	HIGH	HIGH	+20	+22	+29
		HIGH	HIGH	LOW	LOW	+15	+17	+22
		HIGH	HIGH	LOW	HIGH	+10	+12	+17
		HIGH	HIGH	HIGH	LOW	+7.0	+7.9	+11
		HIGH	HIGH	HIGH	HIGH	+3.6	+4.3	+5.6

Table 4. DPD delay time settings (Continued)

DG2	DG1	DL4	DL3	DL2	DL1	DPD delay (ns) ¹		
						min	typ	max
HIGH	LOW	LOW	LOW	LOW	LOW	0	0	0
		LOW	LOW	LOW	HIGH	-7.0	-8.5	-13
		LOW	LOW	HIGH	LOW	-15	-17	-24
		LOW	LOW	HIGH	HIGH	-22	-27	-36
		LOW	HIGH	LOW	LOW	-32	-37	-50
		LOW	HIGH	LOW	HIGH	-43	-48	-65
		LOW	HIGH	HIGH	LOW	-55	-62	-83
		LOW	HIGH	HIGH	HIGH	-70	-78	-108
		HIGH	LOW	LOW	LOW	+90	+100	+136
		HIGH	LOW	LOW	HIGH	+70	+78	+102
		HIGH	LOW	HIGH	LOW	+55	+61	+76
		HIGH	LOW	HIGH	HIGH	+42	+47	+60
		HIGH	HIGH	LOW	LOW	+31	+36	+45
		HIGH	HIGH	LOW	HIGH	+22	+26	+34
		HIGH	HIGH	HIGH	LOW	+14	+17	+23
		HIGH	HIGH	HIGH	HIGH	+7.2	+8.2	+12
HIGH	HIGH	LOW	LOW	LOW	LOW	0	0	0
		LOW	LOW	LOW	HIGH	-9.5	-11	-17
		LOW	LOW	HIGH	LOW	-19	-22	-32
		LOW	LOW	HIGH	HIGH	-30	-35	-49
		LOW	HIGH	LOW	LOW	-42	-48	-74
		LOW	HIGH	LOW	HIGH	-60	-67	-105
		LOW	HIGH	HIGH	LOW	-80	-90	-150
		LOW	HIGH	HIGH	HIGH	-110	-122	-205
		HIGH	LOW	LOW	LOW	+124	+167	+210
		HIGH	LOW	LOW	HIGH	+108	+120	+194
		HIGH	LOW	HIGH	LOW	+80	+88	+130
		HIGH	LOW	HIGH	HIGH	+58	+65	+90
		HIGH	HIGH	LOW	LOW	+42	+47	+64
		HIGH	HIGH	LOW	HIGH	+29	+33	+45
		HIGH	HIGH	HIGH	LOW	+18	+21	+31
		HIGH	HIGH	HIGH	HIGH	+9.0	+10	+16

1. Default is 0 ns (DL4 = DL3 = DL2 = DL1 = LOW)
The DPD delay is positive when (A+C) leads (B+D).

Table 5. Phase difference to voltage converter coefficient

CG3	CG2	CG1	Coefficient (mV/ns) ¹
LOW	LOW	LOW	5.38
LOW	LOW	HIGH	7.58
LOW	HIGH	LOW	10.7
LOW	HIGH	HIGH	15.2
HIGH	LOW	LOW	21.4
HIGH	LOW	HIGH	30.3
HIGH	HIGH	LOW	42.7
HIGH	HIGH	HIGH	60.6

1. Default is 15.2 mV/ns

Table 6. Equalizer control

EQE	Equalizer ¹
LOW	OFF
HIGH	ON

1. Default is OFF

Table 7. DPD output control

DPE	DEFECT	DPD output ¹
LOW	×	Forced to VREF2
×	HIGH	Forced to VREF2
HIGH	LOW	Active

1. Default is VREF2 (DPE = LOW)

Table 8. DPD delay time coefficient, phase difference to voltage converter coefficient, AC coupling time constant

DG2	DG1	Phase to voltage coefficient (relative to values in table 5) ¹	DPD-AC coupling time constant circuit -3dB frequency	Selected media
LOW	LOW	× 1	100 kHz	8-times CD, DVD-RAM
LOW	HIGH	× 1/2		4-times CD
HIGH	LOW	× 1/4	25 kHz	2-times CD
HIGH	HIGH	× 1/8		1-times CD

1. Default is DG2 = DG1 = LOW

Header Position Detector (CAPAP/N → CAPAREA, CAPIN, CAPOUT)

This stage converts a high-speed push-pull signal (CAPAP/CAPAN) to single-ended signals, passes the outputs through low-pass filters to form quantized logic levels which are used as reference signals. These reference signals are level shifted to form plus and minus signals for use by comparators. The amount of level shift can be controlled by serial interface control bits.

After quantization logic conversion, retriggerable mono-multivibrators convert the pulse strings to con-

tinuous signals. This creates inner shifted header CAPIN and an outer shifted header CAPOUT output signals.

In addition, the single-ended signal is also passed through a high-pass filter, which similarly converts to quantized logic signals. Retriggerable mono-multivibrators then convert the pulse strings to continuous signals to create a header area CAPAREA signal. The mono-multivibrator time constants are controlled by serial interface control bits.

Table 9. Slice level shift voltages

LS3	LS2	LS1	Level shift (mV) ¹
LOW	LOW	LOW	±25
LOW	LOW	HIGH	±50
LOW	HIGH	LOW	±75
LOW	HIGH	HIGH	±100
HIGH	LOW	LOW	±125
HIGH	LOW	HIGH	±150
HIGH	HIGH	LOW	±200
HIGH	HIGH	HIGH	±250

1. Default is ±25 mV

Table 10. Mono-multivibrator time constants

MM2	MM1	CAPOUT/CAPIN output (μs) ¹	CAPAREA (μs) ¹
LOW	LOW	4	8 + α
LOW	HIGH	8	16 + α
HIGH	LOW	12	24 + α
HIGH	HIGH	16	32 + α

1. Default is 4 μs and (8 + α), where $\alpha = 6 \times \ln(2V_{LS}/V_H)$, V_H = input signal amplitude, V_{LS} = slice level absolute value shown in table 9.

Table 11. CAPOUT/CAPIN/CAPAREA logic

CAPAREA	HAE ¹	CAPOUT	CAPIN
LOW	LOW	Header signal output	Header signal output
LOW	HIGH	LOW	LOW
HIGH	LOW	Header signal output	Header signal output
HIGH	HIGH	Header signal output	Header signal output

1. Default is LOW

Sample-and-Hold Control Signal Generator

This stage takes the OR-logic of the CAPIN and CAPOUT signals, generated by the header position detector, the CAPSEL and CAPSEEK input signals, and the serial interface control bit HRE and uses them to create a sample-and-hold circuit control signal SHCNT.

The SHCNT is then used in conjunction with serial interface select bits FHE and THE to form the focus sample-and-hold (FSHCNT) and tracking sample-and-hold (TSHCNT) signals.

Table 12. Sample-and-hold logic

CAPIN	CAPOUT	CAPSEL	CAPSEEK	HRE ¹	SHCNT
HIGH	×	×	LOW	HIGH	HIGH
×	HIGH	×	LOW	HIGH	HIGH
LOW	LOW	×	LOW	×	LOW
HIGH	×	×	LOW	LOW	LOW
×	HIGH	×	LOW	LOW	LOW
×	×	HIGH	HIGH	×	HIGH
×	×	LOW	HIGH	×	LOW

1. Default is LOW
 × = don't care.

Table 13. Sample-and-hold signal control logic

FHE ¹	THE ¹	FSHCNT ²	TSHCNT ²
LOW	×	LOW	×
×	LOW	×	LOW
HIGH	×	SHCNT	×
×	HIGH	×	SHCNT

1. Default is LOW
 2. FSHCNT is the focus sample-and-hold control signal, and TSHCNT is the tracking sample-and-hold control signal.
 × = don't care.

Tracking Error Signal Switching (SWA, SWB)

This stage performs tracking error signal switching during DVD-RAM write/read and DVD-ROM and CD

playback. Switching is controlled by serial interface control bits.

Table 14. Tracking error signal select

SWA	SWB	Tracking error signal select ¹
LOW	LOW	S/H
HIGH	HIGH	DPD

1. Default is S/H

Track Count Pulse Generator (TSUB → TRP, TROFF)

This stage filters the tracking error signal through a 6th-order Butterworth low-pass filter which effectively filters off header signal leakage effects. An offset voltage is added and the signal passes through a comparator with hysteresis to generate a track count pulse signal output on TRP. Simultaneously, the window comparator corresponding to the tracking error signal is output as the off-track signal on TROFF (LOW for off-track).

The offset voltage, hysteresis level and window width are controlled by serial interface bits.

Table 15. Offset voltage setting

OF3	OF2	OF1	Offset voltage (mV) ¹
LOW	LOW	LOW	0
LOW	LOW	HIGH	-200
LOW	HIGH	LOW	-400
LOW	HIGH	HIGH	-600
HIGH	LOW	LOW	+800
HIGH	LOW	HIGH	+600
HIGH	HIGH	LOW	+400
HIGH	HIGH	HIGH	+200

1. Default is 0 mV

Sleep Mode

The SM9403BM features 3 sleep modes which can be used when the device is not operating to signifi-

Table 18. Sleep mode settings

SL2	SL1	Mode description ¹
LOW	LOW	Sleep mode OFF (normal operation)
LOW	HIGH	DPD in sleep condition
HIGH	LOW	All except reference voltage supply in sleep condition
HIGH	HIGH	All blocks in sleep condition

1. Default is OFF (SL2 = SL1 = LOW)

Preset Function

When power is applied or in sleep modes 2 and 3, all serial interface flags are reset to their default values with the exception of the sleep mode flags SL2 and SL1 (see the section “Serial Interface”). However,

Table 16. TRP comparator hysteresis

HS3	HS2	HS1	Hysteresis (mV) ¹
LOW	LOW	LOW	±100
LOW	LOW	HIGH	±200
LOW	HIGH	LOW	±300
LOW	HIGH	HIGH	±400
HIGH	LOW	LOW	±500
HIGH	LOW	HIGH	≥ 500
HIGH	HIGH	LOW	≥ 500
HIGH	HIGH	HIGH	≥ 500

1. Default is ±100 mV

Table 17. TROFF comparator window

WD2	WD1	Comparator window (mV) ¹
LOW	LOW	±125
LOW	HIGH	±250
HIGH	LOW	±375
HIGH	HIGH	±475

1. Default is ±125 mV

cantly reduce current consumption. The sleep modes are controlled by serial interface bits.

when writing data to SL2 and SL1 to cancel sleep mode, other flags in the same data word have precedence when writing to the port.

NIPPON PRECISION CIRCUITS INC. reserves the right to make changes to the products described in this data sheet in order to improve the design or performance and to supply the best possible products. Nippon Precision Circuits Inc. assumes no responsibility for the use of any circuits shown in this data sheet, conveys no license under any patent or other rights, and makes no claim that the circuits are free from patent infringement. Applications for any devices shown in this data sheet are for illustration only and Nippon Precision Circuits Inc. makes no claim or warranty that such applications will be suitable for the use specified without further testing or modification. The products described in this data sheet are not intended to use for the apparatus which influence human lives due to the failure or malfunction of the products. Customers are requested to comply with applicable laws and regulations in effect now and hereinafter, including compliance with export controls on the distribution or dissemination of the products. Customers shall not export, directly or indirectly, any products without first obtaining required licenses and approvals from appropriate government agencies.



NIPPON PRECISION CIRCUITS INC.

4-3, Fukuzumi 2-chome
Koto-ku, Tokyo 135-8430, Japan
Telephone: 03-3642-6661
Facsimile: 03-3642-6698

NC9813AE 1999.09