



DC COMPONENTS CO., LTD.

RECTIFIER SPECIALISTS

SMA5920
THRU
SMA5956

TECHNICAL SPECIFICATIONS OF SURFACE MOUNT SILICON ZENER DIODES
VOLTAGE RANGE - 6.2 to 200 Volts POWER - 1.5 Watts

FEATURES

- * Voltage Range: 6.2V to 200V
- * Build-in strain relief
- * Glass passivated junction
- * Low inductance
- * Excellent clamping capability
- * Low profile package

MECHANICAL DATA

- * Case: Molded plastic
- * Epoxy: UL 94V-0 rate flame retardant
- * Terminals: Solder plated, solderable per MIL-STD-750, Method 2026
- * Polarity: As Marked
- * Mounting position: Any
- * Weight: 0.064 gram

MAXIMUM RATINGS AND ELECTRICAL CHARACTERISTICS

Ratings at 25 °C ambient temperature unless otherwise specified.
Single phase, half wave, 60 Hz, resistive or inductive load.
For capacitive load, derate current by 20%.



SMA(DO-214AC)

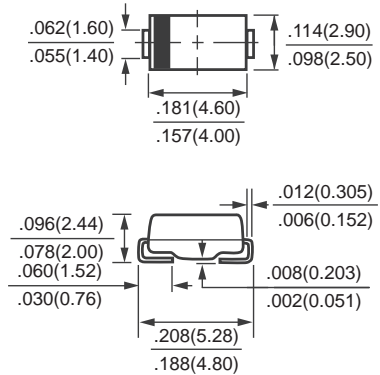

Dimensions in inches(millimeters)

	SYMBOL	VALUE	UNITS
Zener Current see Table "Characteristics"			
Power Dissipation (Notes 1) at Tamb=25°C	Ptot	1.5	W
Peak Forward Surge Current, 8.3ms single half sine-wave superimposed on rated load (JEDEC Method) (Notes 2)	IFSM	10	Amps
Maximum Forward Voltage at IF=200mA	VF	1.5	Volts
Operating and Storage Temperature	TJ, Tstg	-55 to + 150	°C

Notes: 1. Mounted on 5.0mm² (.013mm thick) land areas.

2. Measured on 8.3ms, single half sine-wave or equivalent square wave, duty cycle = 4 pulses per minute maximum.

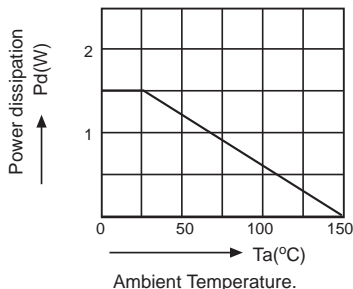

Fig. 1 - changes in the power dissipation due to the ambient temperature.

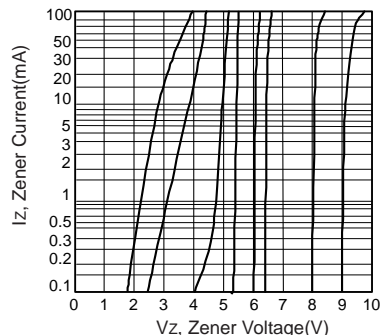

Fig. 2 - Vz=3.9 Thru 10 Volts

RATING AND CHARACTERISTIC CURVES (SMA5920 THRU SMA5956)

TYPE	Nominal Zener Voltage $V_Z @ I_ZT$	Zener Test Current I_ZT mA	Maximum Zener Impedance		I_{ZK} mA	Maximum Reverse Leakage Current		Maximum Regulator Current I_{ZM} mA
			$Z_{ZT} @ I_ZT$ Ohms	$Z_{ZK} @ I_{ZK}$ Ohms		I_R μA	@ V_R Volts	
SMA5920	6.2	60.5	2.0	200	1.00	2.5	4.0	240.0
SMA5921	6.8	55.1	2.5	200	1.00	2.5	5.2	220.0
SMA5922	7.5	50.0	3.0	400	0.50	2.5	6.0	200.0
SMA5923	8.2	45.7	3.5	400	0.50	2.5	6.5	182.0
SMA5924	9.1	41.2	4.0	500	0.50	2.5	7.0	164.0
SMA5925	10.0	37.5	4.5	500	0.25	2.5	8.0	150.0
SMA5926	11.0	34.1	5.5	550	0.25	0.5	8.4	136.0
SMA5927	12.0	31.2	6.5	550	0.25	0.5	9.1	125.0
SMA5928	13.0	28.8	7.0	550	0.25	0.5	9.9	115.0
SMA5929	15.0	25.0	9.0	600	0.25	0.5	11.4	100.0
SMA5930	16.0	23.4	10.0	600	0.25	0.5	12.2	93.0
SMA5931	18.0	20.8	12.0	650	0.25	0.5	13.7	83.0
SMA5932	20.0	18.7	14.0	650	0.25	0.5	15.2	75.0
SMA5933	22.0	17.0	17.5	650	0.25	0.5	16.7	68.0
SMA5934	24.0	15.6	19.0	700	0.25	0.5	18.2	62.0
SMA5935	27.0	13.9	23.0	700	0.25	0.5	20.6	55.0
SMA5936	30.0	12.5	26.0	750	0.25	0.5	22.8	50.0
SMA5937	33.0	11.4	33.0	800	0.25	0.5	25.1	45.0
SMA5938	36.0	10.4	38.0	850	0.25	0.5	27.4	41.0
SMA5939	39.0	9.6	45.0	900	0.25	0.5	29.7	38.0
SMA5940	43.0	8.7	53.0	950	0.25	0.5	32.7	34.0
SMA5941	47.0	8.0	67.0	1000	0.25	0.5	35.8	31.0
SMA5942	51.0	7.3	70.0	1100	0.25	0.5	38.8	29.0
SMA5943	56.0	6.7	86.0	1300	0.25	0.5	42.6	26.0
SMA5944	62.0	6.0	100.0	1500	0.25	0.5	47.1	24.0
SMA5945	68.0	5.5	120.0	1700	0.25	0.5	51.7	22.0
SMA5946	75.0	5.0	140.0	2000	0.25	0.5	56.0	20.0
SMA5947	82.0	4.6	160.0	2500	0.25	0.5	62.2	18.0
SMA5948	91.0	4.1	200.0	3000	0.25	0.5	69.2	16.0
SMA5949	100.0	3.7	250.0	3100	0.25	0.5	76.0	15.0
SMA5950	110.0	3.4	300.0	4000	0.25	0.5	83.6	13.0
SMA5951	120.0	3.1	380.0	4500	0.25	0.5	91.2	12.0
SMA5952	130.0	2.9	450.0	5000	0.25	0.5	98.8	11.0
SMA5953	150.0	2.5	600.0	6000	0.25	0.5	114.0	10.0
SMA5954	160.0	2.3	700.0	6500	0.25	0.5	121.6	9.0
SMA5955	180.0	2.1	900.0	7000	0.25	0.5	136.8	8.0
SMA5956	200.0	1.9	1900.0	8000	0.25	0.5	152.0	7.0

NOTE: Standard Zener Voltage Tolerance $\pm 5\%$

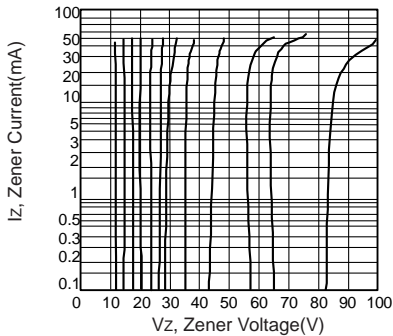

Fig. 3 - $V_Z=12$ Thru 82 Volts

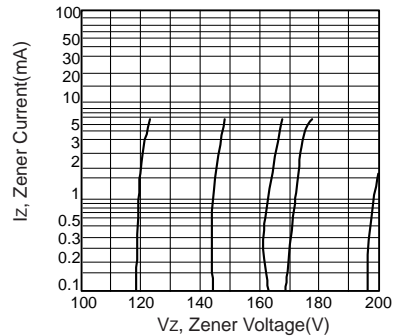

Fig. 4 - $V_Z=100$ Thru 200 Volts



DC COMPONENTS CO., LTD.