

## SMLW010 Single-Output Low-Profile Power Modules: 36 Vdc to 75 Vdc Input; 10 W



The SMLW010 Single-Output, Low-Profile, PCB Mount Power Modules use advanced, surface-mount technology and deliver high-quality, compact, dc-dc conversion at an economical price.

### Applications

- Communications equipment
- Computer equipment
- Distributed power architectures
- Surface-mount applications

### Description

The SMLW010 Single-Output, Low-Profile, PCB Mount Power Modules are low-profile, dc-dc converters that operate over an input voltage range of 36 Vdc to 75 Vdc and provide a precisely regulated output. The output is isolated from the input, allowing versatile polarity configurations and grounding connections. Built-in filtering for both input and output minimizes the need for external filtering. These modules are designed and manufactured to be gull-winged surface-mounted power modules that are reflowed with other surface-mount components in a typical surface-mount fashion.

\* *UL* is a registered trademark of Underwriters Laboratories, Inc.

† *CSA* is a registered trademark of Canadian Standards Association.

‡ This product is intended for integration into end-use equipment. All the required procedures for CE marking of end-use equipments should be followed. (The CE mark is placed on selected products.)

### Features

- Low profile: 8.2 mm x 22.6 mm x 47.8 mm (0.323 in. x 0.89 in. x 1.88 in.)
- Wide input voltage range: 36 Vdc to 75 Vdc
- Input-to-output isolation: 1500 V
- Operating case temperature range: -40 °C to +105 °C
- Overcurrent protection, unlimited duration
- Positive remote on/off logic
- Output voltage adjustment: 90% to 110% of  $V_{O, nom}$
- Output overvoltage protection
- Undervoltage lockout
- *UL*\* 60950 Recognized, *CSA*† C22.2 No. 60950-00 Certified, VDE 0805 (EN60950) Licensed
- CE mark meets 73/23/EEC and 93/68/EEC directives‡
- Within FCC Class A radiated limits

### Options

- Synchronization

## Absolute Maximum Ratings

Stresses in excess of the absolute maximum ratings can cause permanent damage to the device. These are absolute stress ratings only. Functional operation of the device is not implied at these or any other conditions in excess of those given in the operations sections of the data sheet. Exposure to absolute maximum ratings for extended periods can adversely affect device reliability.

Parameter	Device	Symbol	Min	Typ	Max	Unit
Input Voltage: Continuous	SMLW	$V_I$	0	—	80	Vdc
Transient (100 ms)	All	$V_{I, trans}$	0	—	100	V
Operating Case Temperature (See Thermal Considerations section.)	All	$T_C$	-40	—	105*	°C
Storage Temperature	All	$T_{stg}$	-55	—	125	°C
I/O Isolation Voltage (for 1 minute)	All	—	—	—	1500	Vdc

\* See derating curves, Figure 8, for details.

## Electrical Specifications

**Table 1. Input Specifications**

Parameter	Device	Symbol	Min	Typ	Max	Unit
Operating Input Voltage	SMLW	$V_I$	36	48	75	Vdc
Maximum Input Current ( $V_I = 0$ to $V_{I, max}$ ; $I_O = I_{O, max}$ )	SMLW	$I_{I, max}$	—	—	0.6	A
Inrush Transient	All	$I^2t$	—	—	0.2	A <sup>2</sup> s
Input Reflected-ripple Current (5 Hz to 2 0MHz; 12 $\mu$ H source imped- ance; $T_A = 25$ °C; see Figure 1 and Design Considerations section.)	All	$I_i$	—	2	—	mAp-p
Input Ripple Rejection (100 Hz—120 Hz)	All	—	—	50	—	dB

## Fusing Considerations

**CAUTION: This power module is not internally fused. An input line fuse must always be used.**

This encapsulated power module can be used in a wide variety of applications, ranging from simple stand-alone operation to an integrated part of a sophisticated power architecture. To preserve maximum flexibility, internal fusing is not included; however, to achieve maximum safety and system protection, always use an input line fuse. The safety agencies require a normal-blow fuse with a maximum rating of 5 A (see Safety Considerations section). Based on the information provided in this data sheet on inrush energy and maximum dc input current, the same type of fuse with a lower rating can be used. Refer to the fuse manufacturer's data for further information.

## Electrical Specifications (continued)

Table 2. Output Specifications

Parameter	Device Code or Suffix	Symbol	Min	Typ	Max	Unit
Output Voltage Set Point ( $V_I = V_{I, \text{nom}}$ ; $I_O = I_{O, \text{max}}$ ; $T_A = 25\text{ }^\circ\text{C}$ )	G*	$V_{O, \text{set}}$	2.45	2.5	2.55	Vdc
	A	$V_{O, \text{set}}$	4.85	5.0	5.15	Vdc
Output Voltage (Over all line, load, and temperature conditions until end of life; see Figure 3.)	G	$V_O$	2.41	—	2.59	Vdc
	A	$V_O$	4.80	—	5.20	Vdc
Output Regulation: Line ( $V_I = V_{I, \text{min}}$ to $V_{I, \text{max}}$ )  Load ( $I_O = I_{O, \text{min}}$ to $I_{O, \text{max}}$ )  Temperature ( $T_C = -40\text{ }^\circ\text{C}$ to $+85\text{ }^\circ\text{C}$ )	A, G	—	—	1	—	mV
		—	—	0.01	—	% $V_O$
	A, G	—	—	10	—	mV
		—	—	0.1	—	% $V_O$
	A, G	—	—	25	—	mV
—	—	—	—	0.5	—	% $V_O$
Output Ripple and Noise Voltage (Across one 0.1 $\mu\text{F}$ ceramic capacitor; see Figure 2.): RMS	A, G	—	—	—	25	mVrms
		—	—	—	75	mVp-p
External Load Capacitance	A, G	—	0	—	220	$\mu\text{F}$
Output Current (At $I_O < I_{O, \text{min}}$ , the modules may exceed output ripple specifications, but operation is guaranteed. For A, and G codes, the output voltage may exceed specifications when $I_O < I_{O, \text{min}}$ .)	G	$I_O$	0.15	—	3.0	A
	A	$I_O$	0.10	—	2.0	A
Output Current-limit Inception ( $V_O = 90\% V_{O, \text{set}}$ )	All	$I_O$	—	115	—	% $I_{O, \text{max}}$
Output Short-circuit Current ( $V_O = 0.25\text{ V}$ at $25\text{ }^\circ\text{C}$ )	All	$I_O$	—	200	—	% $I_{O, \text{max}}$

\* For output voltages below 2.5 V, the G is trimmable down to 1.5 V.

**Electrical Specifications** (continued)

**Table 2. Output Specifications** (continued)

Parameter	Device Code or Suffix	Symbol	Min	Typ	Max	Unit	
Efficiency ( $V_I = V_{I, \text{nom}}$ ; $I_O = I_{O, \text{max}}$ ; $T_A = 25\text{ }^\circ\text{C}$ ; see Figure 3.)	SMLW010G	$\eta$	—	73	—	%	
	SMLW010A	$\eta$	—	79	—	%	
Switching Frequency	A	—	—	475	—	kHz	
	G	—	—	350	—	kHz	
Dynamic Response ( $\Delta I_O/\Delta t = 1\text{A}/10\text{ }\mu\text{s}$ ; $V_I = V_{I, \text{nom}}$ ; $T_A = 25\text{ }^\circ\text{C}$ ): Load Change from $I_O = 50\%$ to $75\%$ of $I_{O, \text{max}}$ :	All	—	—	3	—	% $V_{O, \text{set}}$	
				Peak Deviation	—	—	ms
	All	—	—	—	1.5	—	ms
					Settling Time ( $V_O < 10\%$ of peak deviation)	—	—
Load Change from $I_O = 50\%$ to $25\%$ of $I_{O, \text{max}}$ :	All	—	—	3	—	% $V_{O, \text{set}}$	
				Peak Deviation	—	—	ms
Settling Time ( $V_O < 10\%$ of peak deviation)	All	—	—	1.5	—	ms	

\* For output voltages below 2.5 V, the G is trimmable down to 1.5V.

† Engineering estimate.

**Table 3. Isolation Specifications**

Parameter	Device	Min	Typ	Max	Unit
Isolation Capacitance (engineering estimate)	All	—	1100	—	pF
Isolation Resistance	All	10	—	—	M $\Omega$

**Table 4. General Specifications**

Parameter	Device	Min	Typ	Max	Unit
Calculated MTBF ( $I_O = 80\%$ of $I_{O, \text{max}}$ ; $T_C = 40\text{ }^\circ\text{C}$ )	All	5,500,000			hours
Weight (engineering estimate)	All	—	—	17 (0.6)	g (oz.)

**Electrical Specifications** (continued)

**Table 5. Feature Specifications**

Parameter	Device Code or Suffix	Symbol	Min	Typ	Max	Unit
Remote On/Off Signal Interface ( $V_I = V_{I, \min}$ to $V_{I, \max}$ ; open collector or equivalent compatible; signal referenced to $V_I(-)$ terminal. See Figure 4 and Feature Descriptions.): Logic Low—Module Off Logic High—Module On Module Specifications: On/Off Current—Logic Low On/Off Voltage: Logic Low Logic High ( $I_{on/off} = 0$ mA) Open Collector Switch Specifications: Leakage Current During Logic High ( $V_{on/off} = 6$ V) Output Low Voltage During Logic Low ( $I_{on/off} = 1$ mA)	All	$I_{on/off}$	—	—	1.0	mA
	All	$V_{on/off}$	-0.7	—	1.2	V
	All	$V_{on/off}$	—	—	6	V
	All	$I_{on/off}$	—	—	50	$\mu$ A
	All	$V_{on/off}$	—	—	1.2	V
Turn-on Delay and Rise Times (at 80% of $I_{O, \max}$ ; $T_A = 25$ °C): Case 1: On/Off Input Is Set for Logic High and then Input Power Is Applied (Delay from Point at Which $V_I = V_{I, \min}$ until $V_O = 10\%$ of $V_{O, \text{nom}}$ ). Case 2: Input Power Is Applied for at Least One Second, and then the On/Off Input Is Set to Logic High (Delay from Point at Which $V_{on/off} = 0.9$ V until $V_O = 10\%$ of $V_{O, \text{nom}}$ ). Output Voltage Rise Time (Time for $V_O$ to Rise from 10% of $V_{O, \text{nom}}$ to 90% of $V_{O, \text{nom}}$ ) Output Voltage Overshoot (at 80% of $I_{O, \max}$ ; $T_A = 25$ °C)	All	$T_{\text{delay}}$	—	15	60	ms
	All	$T_{\text{delay}}$	—	4	10	ms
	All	$T_{\text{rise}}$	—	2	10	ms
	All	—	—	—	5	%
Output Voltage Set Point Adjustment Range	A	$V_{\text{trim}}$	90	—	110	% $V_{O, \text{nom}}$
	G	$V_{\text{trim}}$	60	—	110	% $V_{O, \text{nom}}$
Output Overvoltage Protection (clamp)	G	$V_{O, \text{clamp}}$	3.0	—	5.7	V
	A	$V_{O, \text{clamp}}$	5.6	—	7.7	V
Undervoltage Lockout	All	—	20	27	—	V

**Test Configurations**

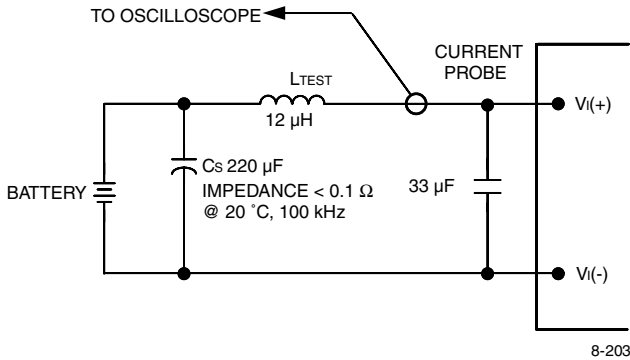

Note: Input reflected-ripple current is measured with a simulated source impedance of 12 µH. Capacitor Cs offsets possible battery impedance. Current is measured at the input of the module.

**Figure 1. Input Reflected-Ripple Test Setup**

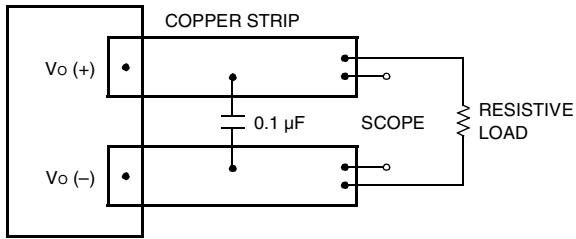

Note: Use one 0.1 µF ceramic capacitor. Scope measurement should be made using a BNC socket. Position the load between 50 mm and 75 mm (2 in. and 3 in.) from the module.

**Figure 2. Peak-to-Peak Output Noise Measurement Test Setup**

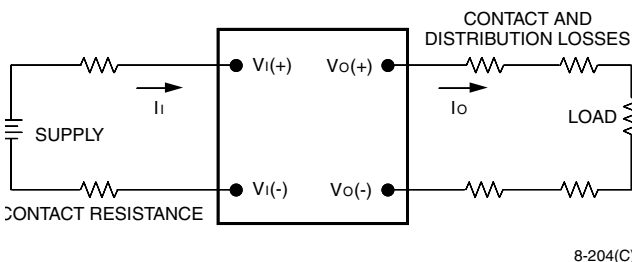

Note: All measurements are taken at the module terminals. When socketing, place Kelvin connections at module terminals to avoid measurement errors due to socket contact resistance.

$$\eta = \left( \frac{[V_o(+)-V_o(-)]I_o}{[V_i(+)-V_i(-)]I_i} \right) \times 100 \%$$

**Figure 3. Output Voltage and Efficiency Measurement Test Setup**

**Design Considerations**

**Input Source Impedance**

The power module should be connected to a low ac-impedance input source. Highly inductive source impedances can affect the stability of the power module. If the source inductance exceeds 10 µH, a 33 µF electrolytic capacitor (ESR < 0.7 Ω at 100 kHz) mounted close to the power module helps ensure stability of the unit. (See Figure 1.)

**Solder Recommendations**

Large surface-mount components typically require a thicker stencil than smaller components to ensure a reliable solder joint. The SMLW010 Single-Output, Low-Profile, PCB Mount Power Modules have been evaluated for solder joint reliability and shock and vibration requirements using 170,000 cubic mils (2.8mm<sup>3</sup>) of solder. This volume can be obtained by printing solder 12 mils thick on the copper pads or overprinting the copper pads 13 mils (0.33 mm) around the pad area with 8 mils of printed solder. Although this volume is recommended, tests have been conducted using lower volumes with successful results. Contact technical support for further assistance.

## Safety Considerations

### SMLW Modules

For safety-agency approval of the system in which the power module is used, the power module must be installed in compliance with the spacing and separation requirements of the end-use safety agency standard, i.e., *UL 60950*, *CSA C22.2 No. 60950-00*, and *VDE 0805 (EN60950)*.

If the input source is non-SELV (ELV or a hazardous voltage greater than 60 Vdc and less than or equal to 75 Vdc), for the module's output to be considered meeting the requirements of safety extra-low voltage (SELV), all of the following must be true:

- The input source is to be provided with reinforced insulation from any other hazardous voltages, including the ac mains.
- One  $V_I$  pin and one  $V_O$  pin are to be grounded or both the input and output pins are to be kept floating.
- The input pins of the module are not operator accessible.
- Another SELV reliability test is conducted on the whole system, as required by the safety agencies, on the combination of supply source and the subject module to verify that under a single fault, hazardous voltages do not appear at the module's output.

**Note:** Do not ground either of the input pins of the module without grounding one of the output pins. This may allow a non-SELV voltage to appear between the output pins and ground.

The power module has extra-low voltage (ELV) outputs when all inputs are ELV.

The input to these units is to be provided with a maximum 5 A normal-blow fuse in the ungrounded lead.

## Feature Descriptions

### Overcurrent Protection

To provide protection in a fault (output overload) condition, the unit is equipped with internal current-limiting circuitry and can endure current limiting for an unlimited duration. At the point of current-limit inception, the unit shifts from voltage control to current control. If the output voltage is pulled very low during a severe fault, the current-limit circuit can exhibit either foldback or tailout characteristics (output-current decrease or increase). The unit operates normally once the output current is brought back into its specified range.

### Remote On/Off

Positive logic remote on/off turns the module on during a logic-high voltage on the remote ON/OFF pin, and off during a logic low.

To turn the power module on and off, the user must supply a switch to control the voltage between the on/off terminal and the  $V_I(-)$  terminal ( $V_{on/off}$ ). The switch may be an open collector or equivalent (see Figure 4). A logic low is  $V_{on/off} = -0.7$  V to 1.2V. The maximum  $I_{on/off}$  during a logic low is 1 mA. The switch should maintain a logic-low voltage while sinking 1 mA.

During a logic high, the maximum  $V_{on/off}$  generated by the power module is 6V. The maximum allowable leakage current of the switch at  $V_{on/off} = 6$  V is 50  $\mu$ A.

The module has internal capacitance to reduce noise at the ON/OFF pin. Additional capacitance is not generally needed and may degrade the start-up characteristics of the module.

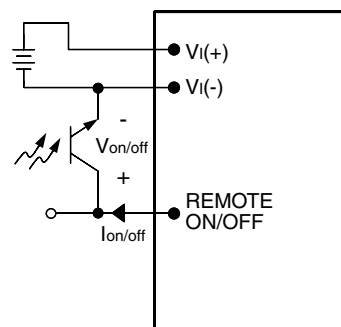

8-758a

Figure 4. Remote On/Off Implementation

### Output Voltage Adjustment

Output voltage set-point adjustment allows the user to increase or decrease the output voltage set point of a module. This is accomplished by connecting an external resistor between the TRIM pin and either the  $V_O(+)$  or  $V_O(-)$  pins. With an external resistor between the TRIM and  $V_O(+)$  pins ( $R_{adj-down}$ ), the output voltage set point ( $V_{O,adj}$ ) decreases (see Figure 5). The following equation determines the required external resistor value to obtain an output voltage change from  $V_{O,nom}$  to  $V_{O,adj}$ :

$$R_{adj-down} = \left[ \frac{(V_{O,adj} - L)G}{(V_{O,nom} - V_{O,adj})} - H \right] \Omega$$

where  $R_{adj-down}$  is the resistance value connected between TRIM and  $V_O(+)$ , and G, H, and L are defined in the table below.

**Feature Descriptions** (continued)

**Output Voltage Adjustment** (continued)

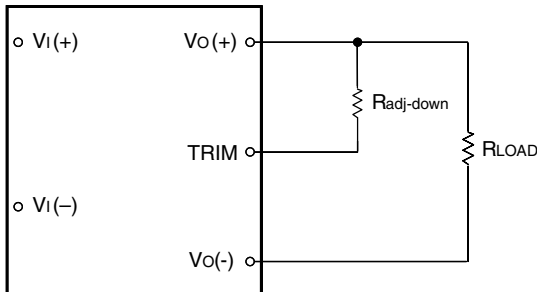

8-715e

**Figure 5. Circuit Configuration to Decrease Output Voltage**

With an external resistor connected between the TRIM and VO(-) pins ( $R_{adj-up}$ ), the output voltage set point ( $V_{O, adj}$ ) increases (see Figure 6). The following equation determines the required external resistor value to obtain an output voltage from  $V_{O, nom}$  to  $V_{O, adj}$ :

$$R_{adj-up} = \left( \left[ \frac{GL}{[(V_{O, adj} - L) - K]} \right] - H \right) \Omega$$

where  $R_{adj-up}$  is the resistance value connected between TRIM and VO(-), and the values of G, H, K, and L are shown in the following table.

	G	H	K	L
SMLx010G	2870	511	1.28	1.23
SMLx010A	4750	2490	3.77	1.23

The combination of the output voltage adjustment and the output voltage regulation cannot exceed 110% of the nominal output voltage between the VO(+) and VO(-) terminals.

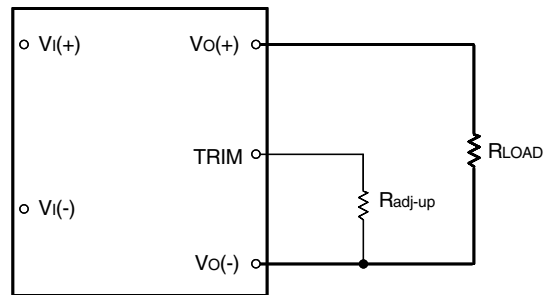

8-715d

**Figure 6. Circuit Configuration to Increase Output Voltage**

The SMLW010 Power Modules have a fixed current-limit set point. Therefore, as the output voltage is adjusted down, the available output power is reduced. In addition, the minimum output current is a function of the output voltage. As the output voltage is adjusted down, the minimum required output current can increase (i.e., minimum power is constant). As the output voltage is adjusted up, the output power should be held constant (maximum load current decreases).

**Output Overvoltage Protection**

The output overvoltage clamp consists of control circuitry, almost entirely independent of the primary regulation loop, that monitors the voltage on the output terminals. This control loop has a higher voltage set point than the primary loop (see Feature Specifications table). In a fault condition, the overvoltage clamp ensures that the output voltage does not exceed  $V_{O, clamp, max}$ . This provides a redundant voltage-control that reduces the risk of output overvoltage.



## Feature Descriptions (continued)

### Synchronization (Optional)

With external circuitry, the unit is capable of synchronization from an independent time base with a switching rate equal to the nominal switching frequency shown in the Output Specifications table. Other frequencies may be available; please consult the factory for application guidelines and/or a description of the external circuit needed to use this feature.

### Thermal Considerations

The power module operates in a variety of thermal environments; however, sufficient cooling should be provided to help ensure reliable operation of the unit. Heat-dissipating components inside the unit are thermally coupled to the case. Heat is removed by conduction, convection, and radiation to the surrounding environment. Proper cooling can be verified by measuring the case temperature. The case temperature ( $T_C$ ) should be measured at the position indicated in Figure 7.

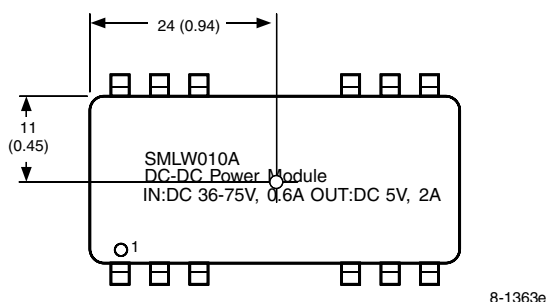

Note: Dimensions are in millimeters and (inches). Pin locations are for reference only.

**Figure 7. SMLW Case Temperature Measurement Location**

Note that the view in Figure 7 is of the surface of the module. The temperature at this location should not exceed the maximum case temperature indicated on the derating curves. The output power of the module should not exceed the rated power for the module as listed in the Ordering Information table.

### Heat Transfer Characteristics

Increasing airflow over the module enhances the heat transfer via convection. Figure 8 shows the maximum power that can be dissipated by the module without exceeding the maximum case temperature versus local ambient temperature ( $T_A$ ) for natural convection through  $3.0 \text{ ms}^{-1}$  (600 ft./min.).

Systems in which these power modules are used typically generate natural convection airflow rates of  $0.25 \text{ ms}^{-1}$  (50 ft./min.) due to other heat-dissipating components in the system. Therefore, the natural convection condition represents airflow rates of approximately  $0.25 \text{ ms}^{-1}$  (50 ft./min.). Use of Figure 8 is shown in the following example.

#### Example

What is the minimum airflow necessary for an SMLW010A operating at  $V_i = 48 \text{ V}$ , an output current of  $1.6 \text{ A}$ , and a maximum ambient temperature of  $86 \text{ }^\circ\text{C}$ ?

#### Solution

Given:  $V_i = 48 \text{ V}$ ,  $I_o = 1.6 \text{ A}$  ( $I_{o, \text{max}}$ ),  $T_A = 86 \text{ }^\circ\text{C}$

Determine  $P_D$  (Figure 9):  $P_D = 2.1 \text{ W}$

Determine airflow (Figure 8):  $v = 1 \text{ ms}^{-1}$  (200 ft./min.)

Thermal Considerations (continued)

Heat Transfer Characteristics (continued)

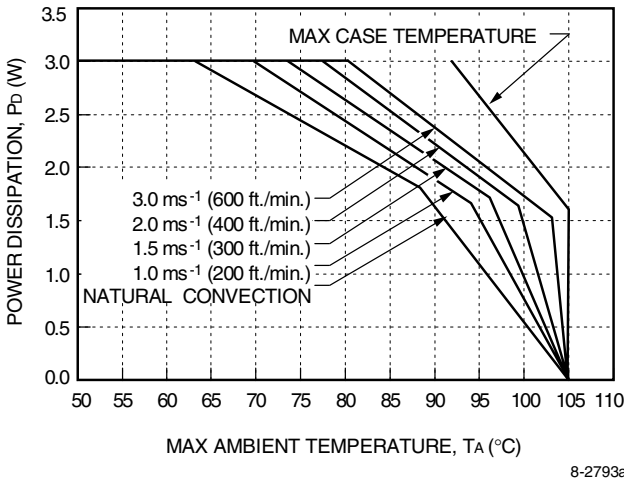

Figure 8. SMLW010A and SMLW010G Forced Convection Power Derating; Either Orientation

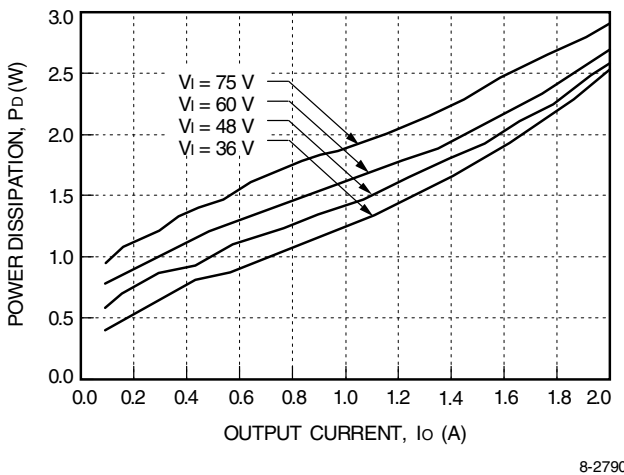
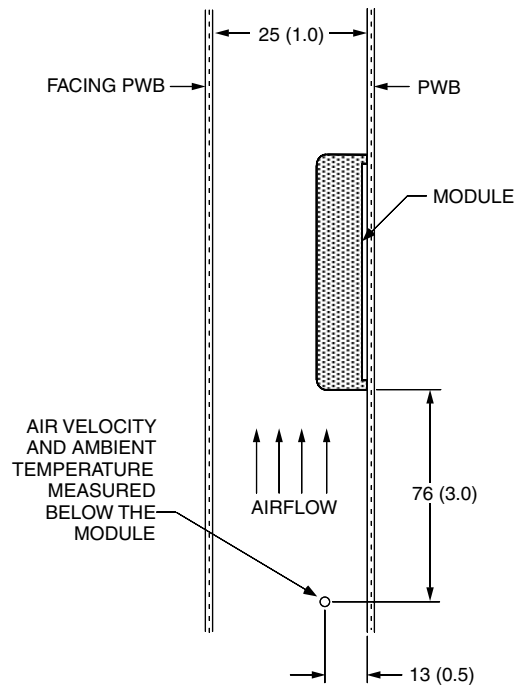

Figure 9. SMLW010A Typical Power Dissipation vs. Normalized Output Current at TA = 25 °C

Module Derating

The derating curves in Figure 8 were derived by measurements obtained in an experimental apparatus shown in Figure 10. Note that the module and the printed-wiring board (PWB) that it is mounted on are both vertically oriented. The passage has a rectangular

cross section.



Note: Dimensions are in millimeters and (inches).

Figure 10. Experimental Test Setup

Surface-Mount Power Module Solder Reflow Recommendation

The SMLW010 Single-Output, Low-Profile, PCB Mount Power Modules are constructed with SMT (surface-mount technology) components and assembly guidelines. Such large mass/low thermal resistance devices heat up slower than typical SMT components. It is recommended that the customer review data sheets in order to customize the solder reflow profile for application board assembly.

It is recommended that a reflow profile must be characterized for the module on the application board assembly. The solder paste type, component, and board thermal sensitivity must be considered in order to form the desired fused solder fillet. The power module leads are plated with tin (Sn) solder to prevent corrosion and ensure good solderability. Typically, the eutectic solder melts at 183 °C, wets the land, and subsequently wicks the device lead. Sufficient time must be allocated to fuse the plating on the lead and ensure a reliable solder joint.

### Surface-Mount Power Module Solder Reflow Recommendation (continued)

There are several types of SMT reflow technologies currently used in the industry. These surface-mount power modules can be adequately soldered using natural convection, IR (radiant infrared), convection/IR, or forced convection technologies. The surface-mount power module solder reflow profile is established by accurately measuring the module gull-wing lead surface temperature.

The maximum oven temperature and conveyor speed should prevent the lead temperature from exceeding the maximum thermal profile limits as shown in Figure 11. The lead temperature during a typical reflow profile is shown in Figure 12. Failure to observe these maximum lead temperatures and duration may result in permanent damage to the power module.

Relative temperatures of the module gull-wing leads vary according to many factors, including surrounding components, internal paths, and connecting paths. Typically, pin 1 is a good choice for a conservative measurement since it is usually connected to heavy paths for current conduction which also tend to heat the lead faster. These variables make it difficult to compare various types of surface-mount modules; however, the unit has been found to be more robust during temperature profiles compared with other SMT modules available in the industry.

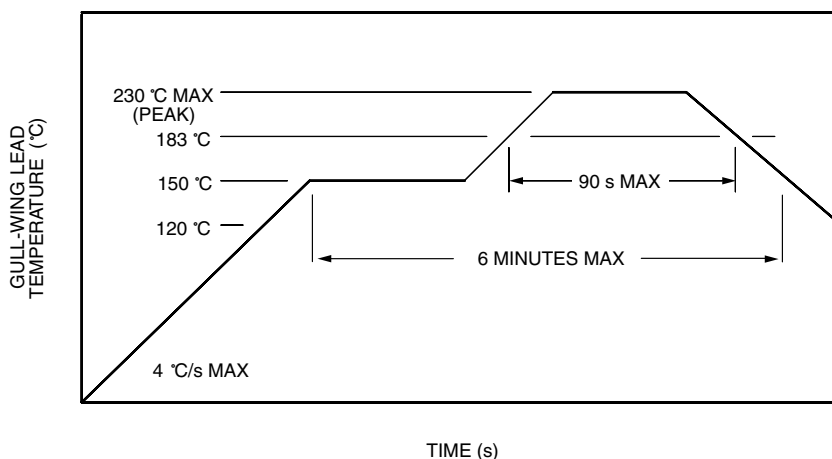

8-2275

Figure 11. Maximum Thermal Profile Limits

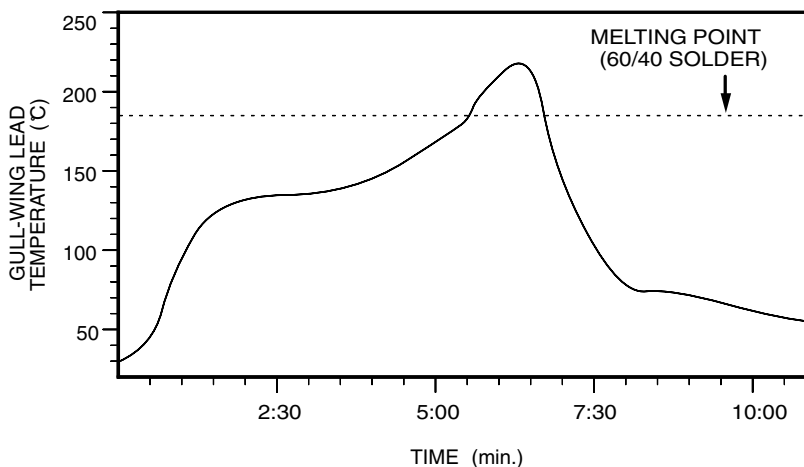

8-2274a

Figure 12. Typical Reflow Soldering Profile

**Packaging Information**

**Vacuum Formed Trays**

The SMLW010 Single-Output, Low-Profile, PCB Mount Power Modules are delivered in plastic vacuum formed trays (see Figure 13) that allow automated placement of the modules via a surface-mount pick and place machine.

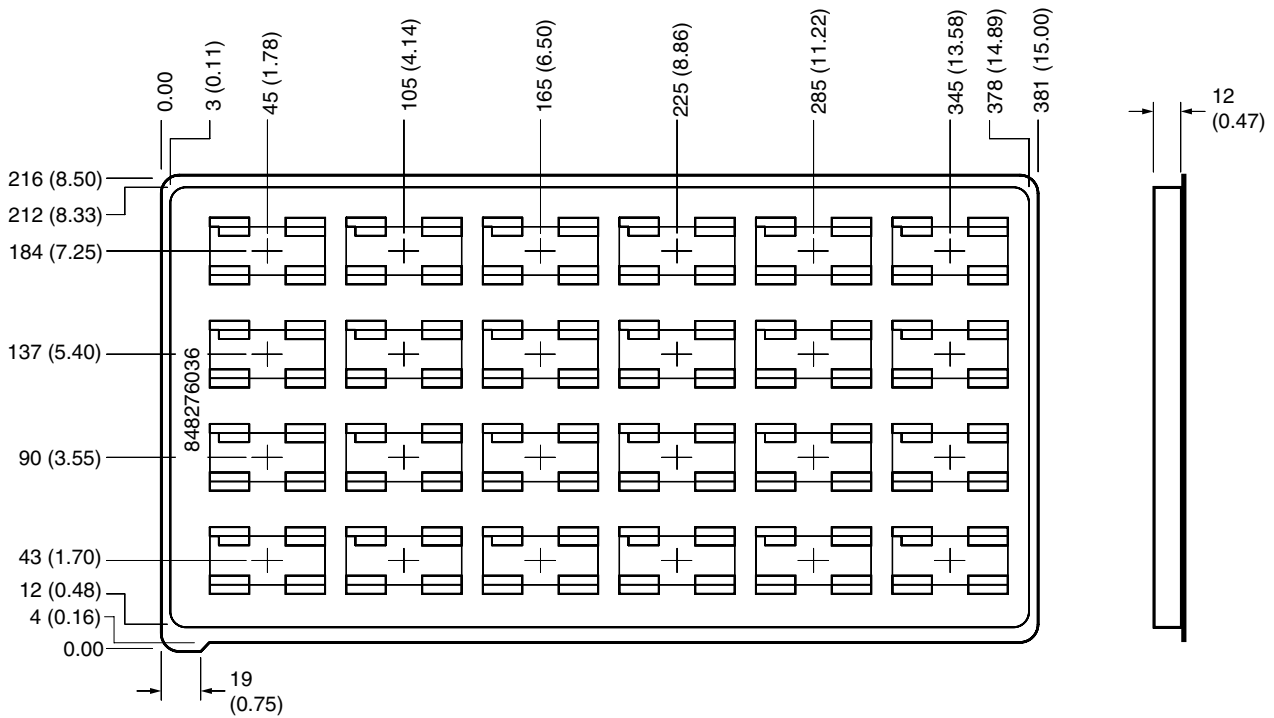

Note: Dimensions are in millimeters and (inches).

8-2792

**Figure 13. Vacuum Formed Tray**

**Specifications:**

- Material: PVC (ESD protected)
- Capacity: 24 pieces/tray
- Weight: 90 g (3.2 oz.)

### Outline Diagram

Dimensions are in millimeters and (inches). See next page for pin descriptions.  
Tolerances:  $x.x \pm 0.5$  mm (0.020 in.);  $x.xx \pm 0.38$  mm (0.015 in.).

#### Top View

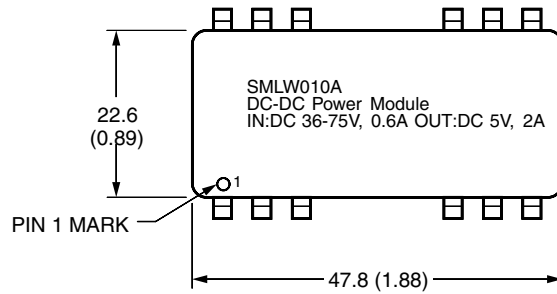

#### Side View

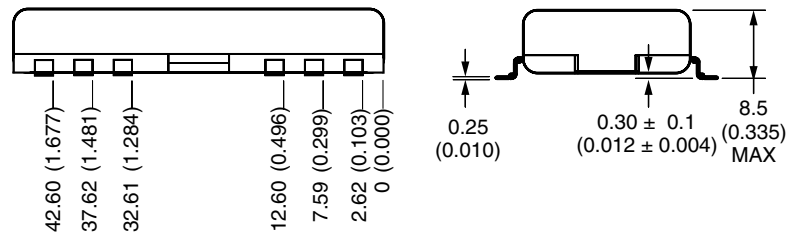

#### Bottom View

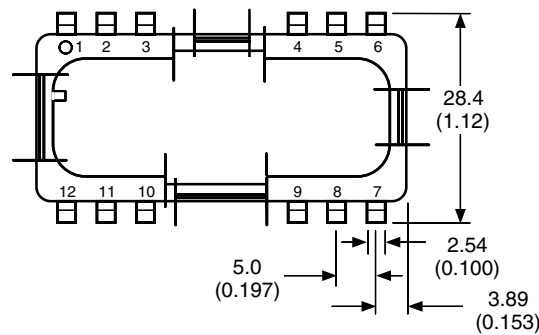

8-2791

**Recommended Hole Pattern**

Component-side footprint. Dimensions are in millimeters and (inches).  
Tolerances: x.x ± 0.5 mm (0.020 in.); x.xx ± 0.38 mm (0.015 in.).

**CAUTION:** Care must be taken to ensure the board in the periphery of the footprint is flat.

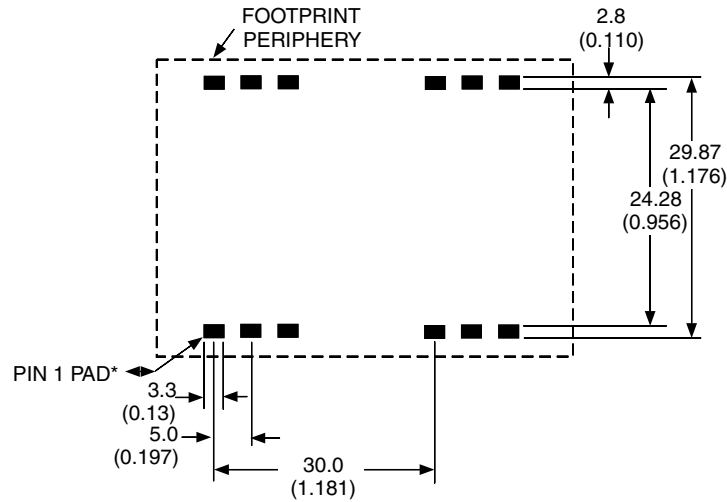

8-1507d

\* The recommended solder paste volume is 2.8 cubic mm (170,000 cubic mils/pin). See Design Considerations section.

Pin	SMLW Function
1	Vo(+)
2	Vo(-)
3	TRIM
4	NC†
5	NC†
6	NC†
7	NC†
8	ON/OFF
9	SYNC (optional)
10	NC†
11	Vi(-)
12	Vi(+)

†NC may be used for internal module connections and should not be connected by the customer.

## Ordering Information

Table 6. Device Codes

Input Voltage	Output Voltage	Output Current	Output Power	Device Code	Comcode
48 V	2.5 V	3 A	7.5 W	SMLW010G	108609744
48 V	5 V	2 A	10 W	SMLW010A	108520396

Optional features may be ordered using the device code suffixes shown below. The feature suffixes are listed numerically in descending order. Please contact your Tyco Electronics' Account Manager or Field Application Engineer for pricing and availability.

Table 7. Device Options

Option	Device Code Suffix
Synchronization*	3

\* Custom option. May not be available on all codes.



**World Wide Headquarters**

**Tyco Electronics Power Systems, Inc.**

3000 Skyline Drive, Mesquite, TX 75149, USA

+1-800-526-7819 FAX: +1-888-315-5182

(Outside U.S.A.: +1-972-284-2626, FAX: +1-972-284-2900)

[www.power.tycoelectronics.com](http://www.power.tycoelectronics.com)

e-mail: [techsupport1@tycoelectronics.com](mailto:techsupport1@tycoelectronics.com)

**Europe, Middle-East and Africa Headquarters**

Tyco Electronics (UK) Ltd

Tel: +44 (0) 1344 469 300, Fax: +44 (0) 1344 469 301

**Central America-Latin America Headquarters**

Tyco Electronics Power Systems

Tel: +54 11 4316 2866, Fax: +54 11 4312 9508

**Asia-Pacific Headquarters**

Tyco Electronics Singapore Pte Ltd

Tel: +65 482 0311, Fax: 65 480 9299

---

Tyco Electronics Corporation reserves the right to make changes to the product(s) or information contained herein without notice. No liability is assumed as a result of their use or application. No rights under any patent accompany the sale of any such product(s) or information.

© 2001 Tyco Electronics Power Systems, Inc. (Mesquite, Texas) All International Rights Reserved.  
Printed in U.S.A.

January 2002  
DS00-089EPS (Replaces DS99-282EPS)

