

SMC/SMW Dual-Output Series Surface-Mount Power Modules: 18 Vdc to 36 Vdc and 36 Vdc to 75 Vdc Inputs, 10 W



The SMC/SMW Dual-Output Series Surface-Mount Power Modules use advanced, surface-mount technology and deliver high-quality, compact, dc-dc conversion at an economical price.

Applications

- Communication equipment
- Computer equipment
- Distributed power architectures

Options

- Negative remote on-off logic
- Synchronization
- Tight output voltage regulation
- Input voltage turn-on adjustment

* *UL* is a registered trademark of Underwriters Laboratories, Inc.
† *CSA* is a registered trademark of Canadian Standards Association.
‡ *VDE* is a trademark of Verband Deutscher Elektrotechniker e.V.
§ This product is intended for integration into end-use equipment. All the required procedures for CE marking of end-use equipment should be followed. (The CE mark is placed on selected products.)

Features

- Low profile: 10 mm x 30.2 mm x 49.5 mm (0.39 in. x 1.19 in. x 1.95 in.)
- Wide input voltage range: 18 Vdc to 36 Vdc and 36 Vdc to 75 Vdc
- Input-to-output isolation: 1500 V
- Operating case temperature range: -40 °C to +105 °C
- Overcurrent protection, unlimited duration
- Remote on/off
- Output voltage adjustment: 90% to 105% of $V_{o, nom}$
- Output overvoltage protection
- Undervoltage lockout
- *UL** 1950 Recognized, *CSA*† C22.2 No. 950-95 Certified, *VDE*‡ 0805 (EN60950, IEC950) Licensed
- CE mark meets 73/23/EEC and 93/68/EEC directives§ (SMW only)
- Within FCC Class A radiated limits

Description

The SMC/SMW Dual-Output Series Surface-Mount Power Modules are low-profile, dc-dc converters that operate over an input voltage range of 18 Vdc to 36 Vdc or 36 Vdc to 75 Vdc and provide a precisely regulated output. The output is isolated from the input, allowing versatile polarity configurations and grounding connections. The modules have a maximum power rating of 10 W and efficiencies up to 80%. Built-in filtering for both input and output minimizes the need for external filtering.

These modules are designed and manufactured to be gull-winged surface-mounted power modules that are reflowed with other surface-mount components in a typical surface-mount fashion.

Absolute Maximum Ratings

Stresses in excess of the absolute maximum ratings can cause permanent damage to the device. These are absolute stress ratings only. Functional operation of the device is not implied at these or any other conditions in excess of those given in the operations sections of the data sheet. Exposure to absolute maximum ratings for extended periods can adversely affect device reliability.

Parameter	Device	Symbol	Min	Typ	Max	Unit
Input Voltage:	SMC	V_I	0	—	50	Vdc
			0	—	80	Vdc
	SMW	$V_{I, trans}$	0	—	100	V
Transient (100 ms)	SMW					
Operating Case Temperature (See Thermal Considerations section.)	All	T_C	-40	—	105*	°C
Storage Temperature	All	T_{stg}	-55	—	120	°C
I/O Isolation Voltage	All	—	—	—	1500	Vdc

* Maximum case temperature varies based on power dissipation. See derating curves, Figure 14, for details.

Electrical Specifications

Unless otherwise indicated, specifications apply over all operating input voltage, resistive load, and temperature conditions.

Table 1. Input Specifications

Parameter	Device	Symbol	Min	Typ	Max	Unit
Operating Input Voltage	SMC	V_I	18	24	36	Vdc
	SMW	V_I	36	48	75	Vdc
Maximum Input Current ($V_I = 0$ to $V_{I, max}$; $I_O = I_{O, max}$)	SMC	$I_{I, max}$	—	—	1.2	A
	SMW	$I_{I, max}$	—	—	0.6	A
Inrush Transient	All	I^2t	—	—	0.2	A ² s
Input Reflected-ripple Current (5 Hz to 20 MHz; 12 μ H source impedance; $T_A = 25$ °C; see Figure 7.)	All	I_I	—	5	—	mAp-p
Input Ripple Rejection (100 Hz—120 Hz)	All	—	—	45	—	dB

Fusing Considerations

CAUTION: This power module is not internally fused. An input line fuse must always be used.

This encapsulated power module can be used in a wide variety of applications, ranging from simple stand-alone operation to an integrated part of a sophisticated power architecture. To preserve maximum flexibility, internal fusing is not included; however, to achieve maximum safety and system protection, always use an input line fuse. The safety agencies require a normal-blow fuse with a maximum rating of 5 A (see Safety Considerations section). Based on the information provided in this data sheet on inrush energy and maximum dc input current, the same type of fuse with a lower rating can be used. Refer to the fuse manufacturer's data for further information.

Electrical Specifications (continued)

Table 2. Output Specifications

Parameter	Device Code or Suffix	Symbol	Min	Typ	Max	Unit	
Output Voltage Set Point ($V_I = V_{I, \text{nom}}$; $I_O = I_{O, \text{max}}$; $T_A = 25\text{ }^\circ\text{C}$)	AJ	$V_{O1, \text{set}}$	4.75	5.0	5.25	Vdc	
		$V_{O2, \text{set}}$	-4.75	-5.0	-5.25	Vdc	
	BK	$V_{O1, \text{set}}$	11.40	12.0	12.60	Vdc	
		$V_{O2, \text{set}}$	-11.40	-12.0	-12.60	Vdc	
	CL	$V_{O1, \text{set}}$	14.25	15.0	15.75	Vdc	
		$V_{O2, \text{set}}$	-14.25	-15.0	-15.75	Vdc	
Output Voltage (Over all line, load, and temperature conditions until end of life; see Figure 9.)	AJ	V_{O1}	4.5	—	5.5	Vdc	
		V_{O2}	-4.5	—	-5.5	Vdc	
	BK	V_{O1}	10.80	—	13.20	Vdc	
		V_{O2}	-10.80	—	-13.20	Vdc	
	CL	V_{O1}	13.50	—	16.50	Vdc	
		V_{O2}	-13.50	—	-16.50	Vdc	
Output Regulation (For line and load see characteristic curves.)	All	—	—	—	—	—	
Output Ripple and Noise (Across 2 x 0.47 μF ceramic capacitors; see Figure 8.): RMS Peak-to-peak (5 Hz to 20 MHz)	AJ	—	—	—	35	mVrms	
	BK, CL	—	—	—	50	mVrms	
	AJ	—	—	—	120	mVp-p	
	BK, CL	—	—	—	150	mVp-p	
Output Current (At $I_O < I_{O, \text{min}}$, the modules may exceed output ripple specifications, but operation is guaranteed.)	AJ	I_{O1}, I_{O2}	0.1	—	1.0	A	
	BK	I_{O1}, I_{O2}	0.06	—	0.42	A	
	CL	I_{O1}, I_{O2}	0.05	—	0.33	A	
Output Current-limit Inception ($V_O = 90\% V_{O, \text{set}}$)	AJ	I_{O1}, I_{O2}	—	—	4.0	A	
	BK	I_{O1}, I_{O2}	—	—	2.5	A	
	CL	I_{O1}, I_{O2}	—	—	2.5	A	
Output Short-circuit Current ($V_O = 0.25\text{ V}$)	AJ	I_{O1}, I_{O2}	—	—	6.0	A	
	BK	I_{O1}, I_{O2}	—	—	3.5	A	
	CL	I_{O1}, I_{O2}	—	—	3.5	A	
Efficiency ($V_I = V_{I, \text{nom}}$; $I_O = I_{O, \text{max}}$; $T_A = 25\text{ }^\circ\text{C}$; see Figure 9.)	SMC010xx	η	TBD	77	—	%	
	SMW010AJ	η	TBD	78	—	%	
	SMW010BK	η	76	79	—	%	
	SMW010CL	η	76	79	—	%	
Switching Frequency	All	—	—	265	—	kHz	

Electrical Specifications (continued)

Table 2. Output Specifications (continued)

Parameter	Device Code or Suffix	Symbol	Min	Typ	Max	Unit
Dynamic Response (for duals: I_{O1} or $I_{O2} = I_{O, max}$; $\Delta I_O/\Delta t = 1A/10 \mu s$; $V_I = V_{I, nom}$; $T_A = 25 \text{ }^\circ\text{C}$):						
Load Change from $I_O = 50\%$ to 75% of $I_{O, max}$:						
Peak Deviation	All	—	—	2	—	$\%V_{O, set}$
Settling Time ($V_O < 10\%$ of peak deviation)	All	—	—	1.5	—	ms
Load Change from $I_O = 50\%$ to 25% of $I_{O, max}$:						
Peak Deviation	All	—	—	2	—	$\%V_{O, set}$
Settling Time ($V_O < 10\%$ of peak deviation)	All	—	—	1.5	—	ms

Table 3. Isolation Specifications

Parameter	Min	Typ	Max	Unit
Isolation Capacitance	—	600	—	pF
Isolation Resistance	10	—	—	$M\Omega$

Table 4. General Specifications

Parameter	Min	Typ	Max	Unit
Calculated MTBF ($I_O = 80\%$ of $I_{O, max}$; $T_C = 40 \text{ }^\circ\text{C}$)	4,860,000			hours
Weight	—	—	30 (1.05)	g (oz.)

Electrical Specifications (continued)

Table 5. Feature Specifications

Parameter	Device Code or Suffix	Symbol	Min	Typ	Max	Unit
Remote On/Off Signal Interface (optional): ($V_I = 0\text{ V}$ to $V_{I, \text{max}}$; open collector or equivalent compatible; signal referenced to $V_I(-)$ terminal. See Figure 10 and Feature Descriptions.): Positive Logic— If Device Code Suffix “1” Is Not Specified: Logic Low—Module Off Logic High—Module On Negative Logic— Device Code Suffix “1”: Logic Low—Module On Logic High—Module Off Module Specifications: On/Off Current—Logic Low On/Off Voltage: Logic Low Logic High ($I_{\text{on/off}} = 0$) Open Collector Switch Specifications: Leakage Current During Logic High ($V_{\text{on/off}} = 10\text{ V}$) Output Low Voltage During Logic Low ($I_{\text{on/off}} = 1\text{ mA}$)	All	$I_{\text{on/off}}$	—	—	1.0	mA
	All	$V_{\text{on/off}}$	-0.7	—	1.2	V
	All	$V_{\text{on/off}}$	—	—	10	V
	All	$I_{\text{on/off}}$	—	—	50	μA
	All	$V_{\text{on/off}}$	—	—	1.2	V
Turn-on Delay and Rise Times (At 80% of $I_{O, \text{max}}$; $T_A = 25\text{ }^\circ\text{C}$): Case 1: On/Off Input Is Set for Unit On and then Input Power Is Applied (delay from point at which $V_I = V_{I, \text{min}}$ until $V_O = 10\%$ of $V_{O, \text{nom}}$). Case 2: Input Power Is Applied for at Least One Second, and then the On/Off Input Is Set to Turn the Module On (delay from point at which on/off input is toggled until $V_O = 10\%$ of $V_{O, \text{nom}}$). Output Voltage Rise Time (time for V_O to rise from 10% of $V_{O, \text{nom}}$ to 90% of $V_{O, \text{nom}}$) Output Voltage Overshoot (at 80% of $I_{O, \text{max}}$; $T_A = 25\text{ }^\circ\text{C}$)	All	T_{delay}	—	5	20	ms
	All	T_{delay}	—	1	10	ms
	All	T_{rise}	—	0.2	5	ms
	All	—	—	—	5	%
Output Voltage Set-point Adjustment Range	AJ BK, CL	— —	90 90	— —	110 100	% $V_{O, \text{nom}}$ % $V_{O, \text{nom}}$
Output Overvoltage Protection (clamp)	AJ BK CL	$V_{O1, \text{clamp}}$ $V_{O2, \text{clamp}}$ $V_{O1, \text{clamp}}$ $V_{O2, \text{clamp}}$ $V_{O1, \text{clamp}}$ $V_{O2, \text{clamp}}$	5.6 -5.6 13.2 -13.2 16.6 -16.6	— — — — — —	7.0 -7.0 18.0 -18.0 22.0 -22.0	V V V V V V
Undervoltage Lockout	SMC SMW	V_{uvlo} V_{uvlo}	11 20	14 27	— —	V V

Characteristic Curves

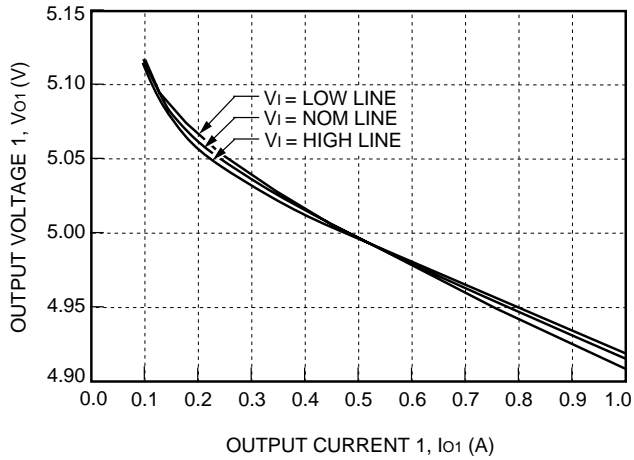

8-1790(C)

Note: Output 2 has characteristics similar to output 1 when $I_{o1} = 0.5 \text{ A}$ and I_{o2} varies.

Figure 1. SMx010AJ Typical Load Regulation of Output1 with Fixed $I_{o2} = 0.5 \text{ A}$ at $T_c = 25 \text{ }^\circ\text{C}$

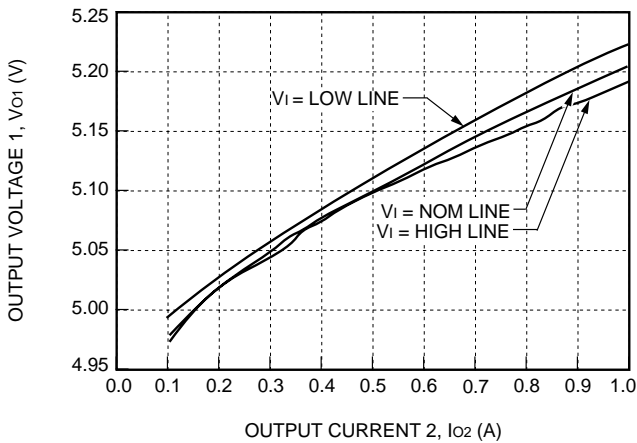

8-1791(C)

Note: Output 2 has characteristics similar to output 1 when $I_{o2} = 0.1 \text{ A}$ and I_{o1} varies.

Figure 2. SMx010AJ Typical Cross Regulation, V_{o1} vs. I_{o2} with Fixed $I_{o1} = 0.1 \text{ A}$ at $T_c = 25 \text{ }^\circ\text{C}$

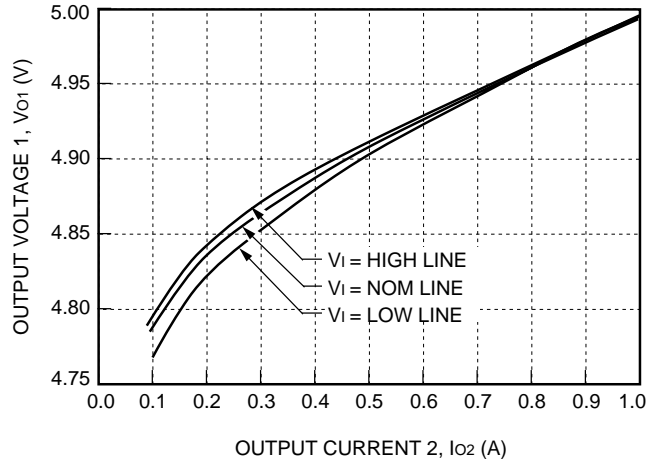

8-1792(C)

Note: Output 2 has characteristics similar to output 1 when $I_{o2} = 1.0 \text{ A}$ and I_{o1} varies.

Figure 3. SMx010AJ Typical Cross Regulation, V_{o1} vs. I_{o2} with Fixed $I_{o1} = 1.0 \text{ A}$ at $T_c = 25 \text{ }^\circ\text{C}$

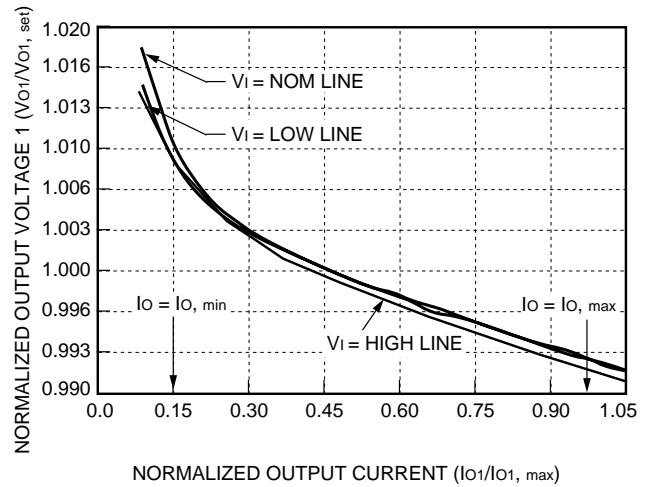

8-1793(C)

Note: Output 2 has characteristics similar to output 1 when $I_{o1} = (0.5 * I_{o, \text{max}})$ and I_{o2} varies.

Figure 4. SMx010BK, CL Load Regulation of Output1 with Fixed $I_{o2} = 0.5 * I_{o, \text{max}}$ at $T_c = 25 \text{ }^\circ\text{C}$, Normalized V_{o1} vs. Normalized Current I_{o1}

Characteristics Curves (continued)

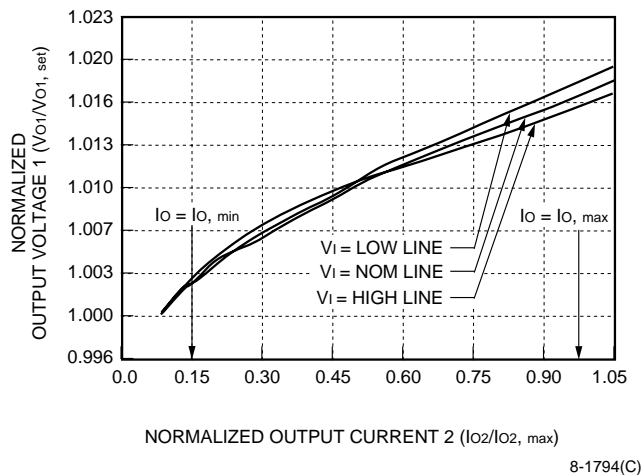

Note: Output 2 has characteristics similar to output 1 when $Io_2 = Io_{, min}$ and Io_1 varies.

Figure 5. SMx010BK, CL Typical Cross Regulation, Normalized V_{o1} vs. Normalized Io_2 with Fixed $Io_1 = Io_{, min}$ at $T_c = 25^\circ C$

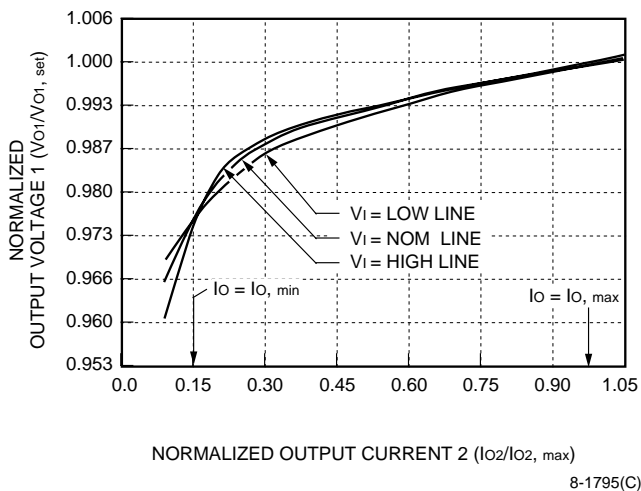

Note: Output 2 has characteristics similar to output 1 when $Io_2 = Io_{, max}$ and Io_1 varies.

Figure 6. SMx010BK, CL Typical Cross Regulation, Normalized V_{o1} vs. Normalized Io_2 with Fixed $Io_1 = Io_{, max}$ at $T_c = 25^\circ C$

Test Configurations

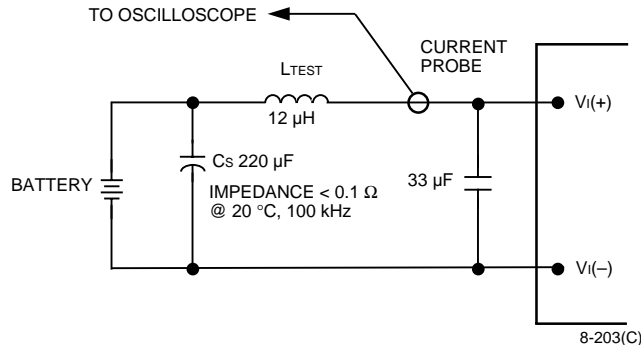

Note: Input reflected-ripple current is measured with a simulated source impedance of 12 μH . Capacitor C_s offsets possible battery impedance. Current is measured at the input of the module.

Figure 7. Input Reflected-Ripple Test Setup

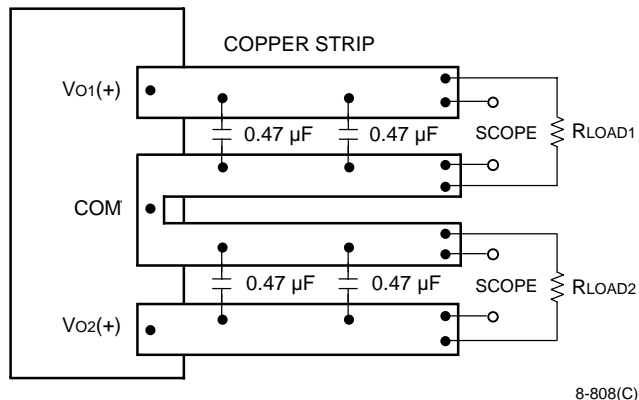

Note: Use four 0.47 μF ceramic capacitors. Scope measurement should be made using a BNC socket. Position the load between 50 mm and 75 mm (2 in. and 3 in.) from the module.

Figure 8. Peak-to-Peak Output Noise Measurement Test Setup

Test Configurations (continued)

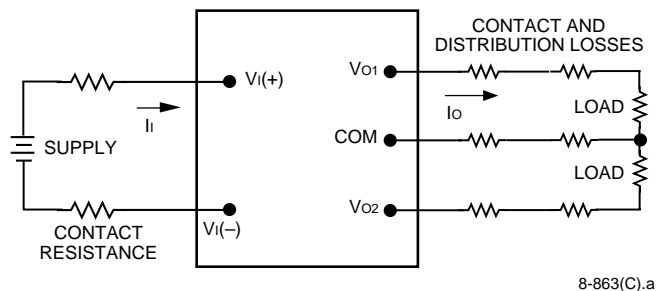

Note: All measurements are taken at the module terminals. When socketing, place Kelvin connections at module terminals to avoid measurement errors due to socket contact resistance.

$$\eta = \left[\frac{\sum_{j=1}^2 | [V_{Oj} - COM] I_{Oj} |}{[V_{i(+)} - V_{i(-)}] I_i} \right] \times 100 \quad \%$$

Figure 9. Output Voltage and Efficiency Measurement Test Setup

Design Considerations

Input Source Impedance

The power module should be connected to a low ac-impedance input source. Highly inductive source impedances can affect the stability of the power module. If the source inductance exceeds 4 μ H, a 33 μ F electrolytic capacitor (ESR < 0.7 Ω at 100 kHz) mounted close to the power module helps ensure stability of the unit.

Solder Recommendations

Large surface-mount components typically require a thicker stencil than smaller components to ensure a reliable solder joint. The SMC/SMW-Series Surface-Mount Power Modules have been evaluated for solder joint reliability and shock and vibration requirements using 170,000 cubic mils (2.8 mm³) of solder. This volume can be obtained by printing solder 12 mils thick on the copper pads on overprinting the copper pads 13 mils (0.33 mm) around the pad area with 8 mils of printed solder. Although this volume is recommended, tests have been conducted using lower volumes with successful results. Contact technical support for further assistance.

Safety Considerations

SMC Modules

For safety-agency approval of the system in which the power module is used, the power module must be installed in compliance with the spacing and separation requirements of the end-use safety agency standard, i.e., *UL 1950*, *CSA C22.2 No. 950-95*, and *VDE 0805 (EN60950, IEC950)*.

For the converter output to be considered meeting the requirements of safety extra-low voltage (SELV), the input must meet SELV requirements.

The power module has extra-low voltage (ELV) outputs when all inputs are ELV.

The input to these units is to be provided with a maximum 5 A normal-blow fuse in the ungrounded lead.

SMW Modules

For safety-agency approval of the system in which the power module is used, the power module must be installed in compliance with the spacing and separation requirements of the end-use safety agency standard, i.e., *UL 1950*, *CSA C22.2 No. 950-95*, and *VDE 0805 (EN60950, IEC950)*.

If the input source is non-SELV (ELV or a hazardous voltage greater than 60 Vdc and less than or equal to 75 Vdc), for the module's output to be considered meeting the requirements of safety extra-low voltage (SELV), all of the following must be true:

- The input source is to be provided with reinforced insulation from any other hazardous voltages, including the ac mains.
- One Vi pin and one Vo pin are to be grounded, or both the input and output pins are to be kept floating.
- The input pins of the module are not operator accessible.
- Another SELV reliability test is conducted on the whole system, as required by the safety agencies, on the combination of supply source and the subject module to verify that under a single fault, hazardous voltages do not appear at the module's output.

Note: Do not ground either of the input pins of the module without grounding one of the output pins. This may allow a non-SELV voltage to appear between the output pins and ground.

Safety Considerations (continued)

SMW Modules (continued)

The power module has extra-low voltage (ELV) outputs when all inputs are ELV.

The input to these units is to be provided with a maximum 5 A normal-blow fuse in the ungrounded lead.

Feature Descriptions

Overcurrent Protection

To provide protection in a fault (output overload) condition, the unit is equipped with internal current-limiting circuitry and can endure current limiting for an unlimited duration. At the point of current-limit inception, the unit shifts from voltage control to current control. If the output voltage is pulled very low during a severe fault, the current-limit circuit can exhibit either foldback or tailout characteristics (output-current decrease or increase). The unit operates normally once the output current is brought back into its specified range.

Remote On/Off

Two remote on/off options are available. Positive logic (if device code suffix "1" is not specified) remote on/off turns the module on during a logic-high voltage on the remote ON/OFF pin, and off during a logic low. Negative logic, device code suffix "1," remote on/off turns the module off during a logic high and on during a logic low or when the remote ON/OFF pin is shorted to the $V_I(-)$ pin.

To turn the power module on and off, the user must supply a switch to control the voltage between the on/off terminal and the $V_I(-)$ terminal ($V_{on/off}$). The switch may be an open collector or equivalent (see Figure 10). A logic low is $V_{on/off} = -0.7$ V to 1.2 V. The maximum $I_{on/off}$ during a logic low is 1 mA. The switch should maintain a logic-low voltage while sinking 1 mA.

During a logic high, the maximum $V_{on/off}$ generated by the power module is 10 V. The maximum allowable leakage current of the switch at $V_{on/off} = 10$ V is 50 μ A.

The module has internal capacitance to reduce noise at the ON/OFF pin. Additional capacitance is not generally needed and may degrade the start-up characteristics of the module.

If not using the remote on/off feature, perform one of the following:

For negative logic, short the ON/OFF pin to $V_I(-)$.

For positive logic, leave the ON/OFF pin open (floating).

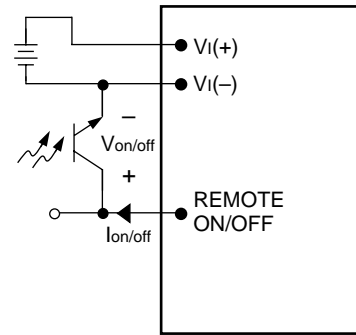

8-758(C).a

Figure 10. Remote On/Off Implementation

Output Voltage Adjustment

Output voltage set point adjustment allows the user to increase or decrease the output voltage set point of a module. This is accomplished by connecting an external resistor between the TRIM pin and either the $V_O(+)$ or $V_O(-)$ pins. With an external resistor between the TRIM and $V_O(+)$ pins ($R_{adj-down}$), the output voltage set point ($V_{O, adj}$) decreases (see Figure 11). The following equation determines the required external resistor value to obtain an output voltage change from $V_{O, nom}$ to $V_{O, adj}$:

$$R_{adj-down} = \left[\frac{(V_{O, adj} - L)G}{(V_{O, nom} - V_{O, adj})} - H \right] \Omega$$

where $R_{adj-down}$ is the resistance value connected between TRIM and $V_O(+)$, and G, H, and L are defined in the table below.

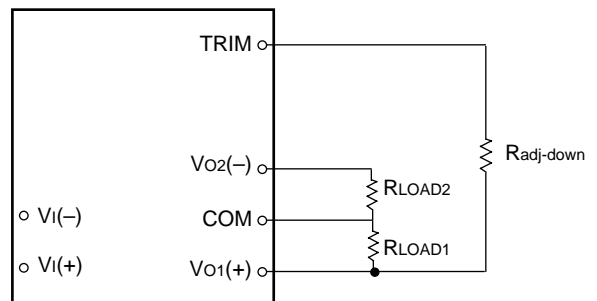

8-715(C).j

Figure 11. Circuit Configuration to Decrease Output Voltage

Feature Descriptions (continued)

Output Voltage Adjustment (continued)

With an external resistor connected between the TRIM and VO(-) pins (R_{adj-up}), the output voltage set point ($V_{O,adj}$) increases (see Figure 12). The following equation determines the required external resistor value to obtain an output voltage from $V_{O,nom}$ to $V_{O,adj}$:

$$R_{adj-up} = \left(\left[\frac{GL}{[(V_{O,adj} - L) - K]} \right] - H \right) \Omega$$

where R_{adj-up} is the resistance value connected between TRIM and VO(-), and the values of G, H, K, and L are shown in the following table.

	G	H	K	L
SMx010AJ	10000	2050	7.5	2.49
SMx010BK	45300	2050	—	2.49
SMx010CL	45300	2050	—	2.49

Although the AJ output can be trimmed up, with mismatched loads, the output voltage on the lightly loaded output will increase. The output voltage between the COM pin and both the VO1(+) and VO2(-) pins must be kept lower than the minimum overvoltage protection voltage found in the Feature Specifications table. The BK and CL modules can only be trimmed down.

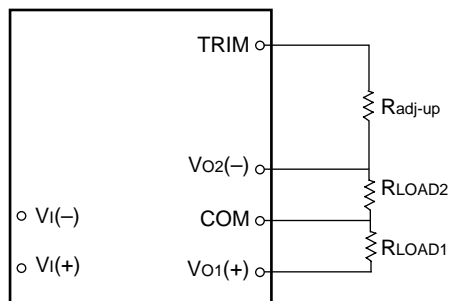

8-715(C).k

Figure 12. Circuit Configuration to Increase Output Voltage

The SMC/SMW-Series Surface-Mount Power Modules have a fixed current-limit set point. Therefore, as the output voltage is adjusted down, the available output power is reduced. In addition, the minimum output current is a function of the output voltage. As the output voltage is adjusted down, the minimum required output current can increase (i.e., minimum power is constant). As the output voltage is adjusted up, the output power should be held constant (maximum load current decreases).

Output Overvoltage Protection

The output overvoltage clamp consists of control circuitry, independent of the primary regulation loop, that monitors the voltage on the output terminals. This control loop has a higher voltage set point than the primary loop (see Feature Specifications table). In a fault condition, the overvoltage clamp ensures that the output voltage does not exceed $V_{O,clamp,max}$. This provides a redundant voltage-control that reduces the risk of output overvoltage.

Input Voltage Turn-On Adjustment (Optional)

The input voltage at which the unit turns on can be adjusted upward to add additional hysteresis between the points at which the modules turn on and turn off.

This feature can be useful when the power system has high impedance between the source voltage and the power unit causing the input to drop as the supply is turned on. Please consult the factory for application guidelines and/or a description of how to use this feature.

Synchronization (Optional)

With external circuitry, the unit is capable of synchronization from an independent time base with a switching rate of 256 kHz. Other frequencies may be available; please consult the factory for application guidelines and/or a description of the external circuit needed to use this feature.

Thermal Considerations

The power module operates in a variety of thermal environments; however, sufficient cooling should be provided to help ensure reliable operation of the unit. Heat-dissipating components inside the unit are thermally coupled to the case. Heat is removed by conduction, convection, and radiation to the surrounding environment. Proper cooling can be verified by measuring the case temperature. The case temperature (T_c) should be measured at the position indicated in Figure 13.

Thermal Considerations (continued)

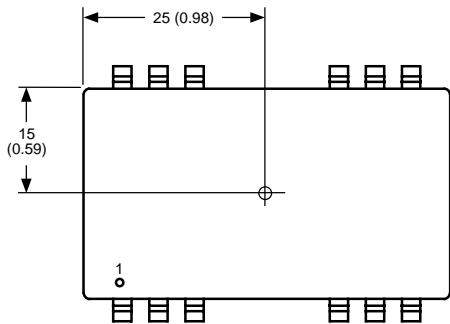

8-1363(C).d

Note: Dimensions are in millimeters and (inches). Pin locations are for reference only.

Figure 13. SMC and SMW Case Temperature Measurement Location

Note that the view in Figure 13 is of the surface of the module. The temperature at this location should not exceed the maximum case temperature indicated on the derating curves. The output power of the module should not exceed the rated power for the module as listed in the Ordering Information table.

Heat Transfer Characteristics

Increasing airflow over the module enhances the heat transfer via convection. Figure 14 shows the maximum power that can be dissipated by the module without exceeding the maximum case temperature versus local ambient temperature (T_A) for natural convection through 3.0 ms^{-1} (600 ft./min.).

Systems in which these power modules are used typically generate natural convection airflow rates of 0.25 ms^{-1} (50 ft./min.) due to other heat-dissipating components in the system. Therefore, the natural convection condition represents airflow rates of approximately 0.25 ms^{-1} (50 ft./min.). Use of Figure 14 is shown in the following example.

Example

What is the minimum airflow necessary for an SMW010AJ operating at $V_I = 48 \text{ V}$, an output current of $\pm 1 \text{ A}$, and a maximum ambient temperature of $84 \text{ }^\circ\text{C}$?

Solution:

Given: $V_I = 48 \text{ V}$, $I_O = \pm 1 \text{ A}$ ($I_{O, \text{max}}$), $T_A = 84 \text{ }^\circ\text{C}$
 Determine P_D (Figure 16): $P_D = 2.50 \text{ W}$
 Determine airflow (Figure 14): $v = 1 \text{ ms}^{-1}$
 (200 ft./min.)

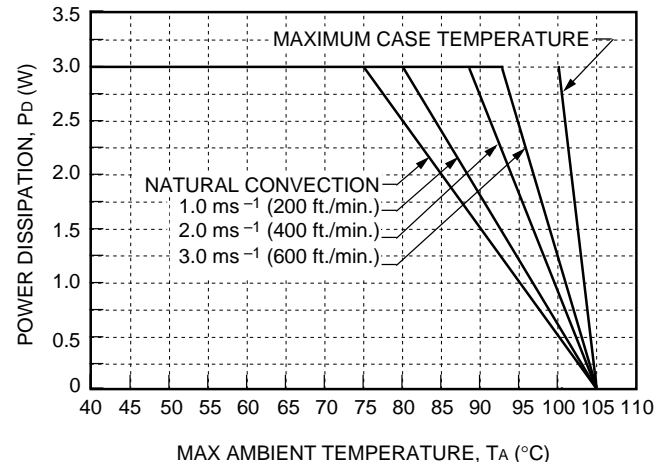

8-1375(C).b

Figure 14. SMC010/SMW010 Forced Convection Power Derating; Either Orientation

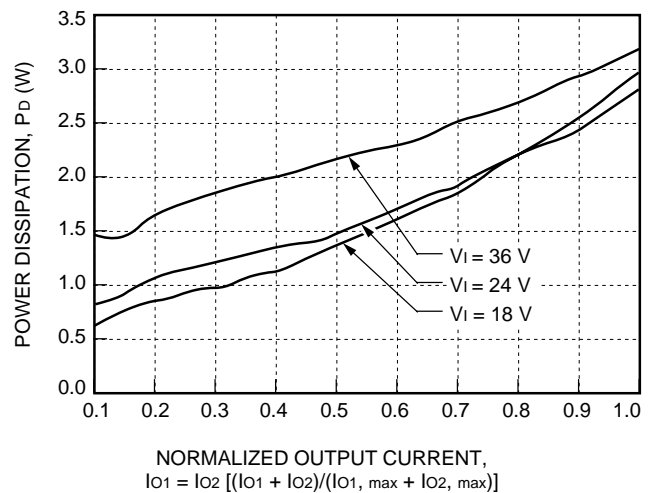

8-1813(C)

Figure 15. SMC010AJ, BK, CL Typical Power Dissipation vs. Normalized Output Current at $T_c = 25 \text{ }^\circ\text{C}$

Thermal Considerations (continued)

Heat Transfer Characteristics (continued)

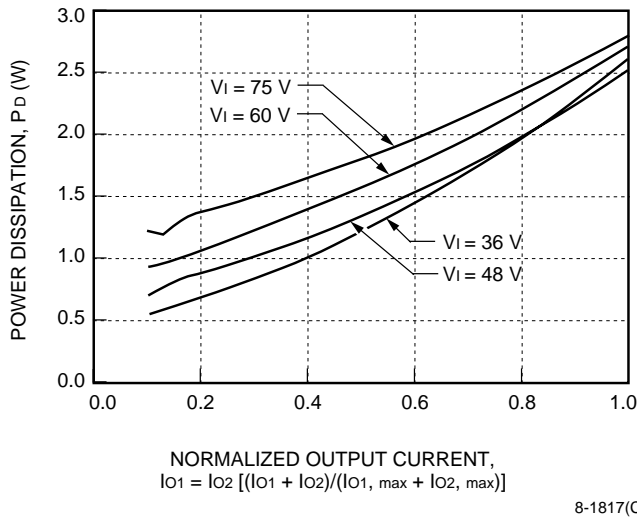
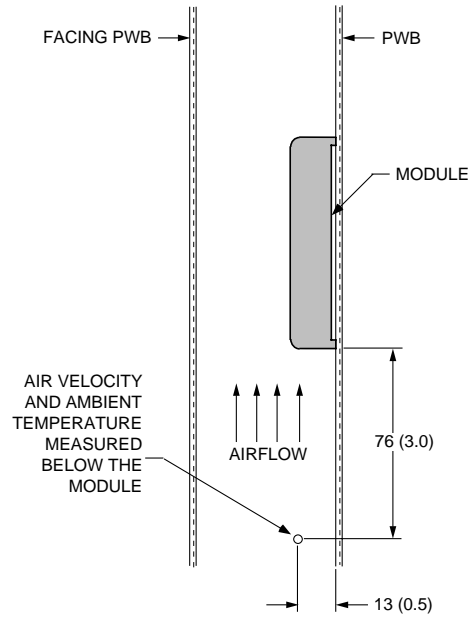

Figure 16. SMW010AJ, BK, CL Typical Power Dissipation vs. Normalized Output Current at $T_c = 25^\circ\text{C}$

Module Derating

The derating curves in Figure 14 were derived by measurements obtained in an experimental apparatus shown in Figure 17. Note that the module and the printed-wiring board (PWB) that it is mounted on are both vertically oriented. The passage has a rectangular cross section.



Note: Dimensions are in millimeters and (inches).

Figure 17. Experimental Test Setup

Surface-Mount Power Module Solder Reflow Recommendation

The SMC/SMW-Series surface-mount power modules are constructed with SMT (surface-mount technology) components and assembly guidelines. Such large mass/low thermal resistance devices heat up slower than typical SMT components. It is recommended that the customer review data sheets in order to customize the solder reflow profile for application board assembly.

It is recommended that a reflow profile must be characterized for the module on the application board assembly. The solder paste type, component, and board thermal sensitivity must be considered in order to form the desired fused solder fillet. The power module leads are plated with tin (Sn) solder to prevent corrosion and ensure good solderability. Typically, the eutectic solder melts at 183°C , wets the land, and subsequently wicks the device lead. Sufficient time must be allocated to fuse the plating on the lead and ensure a reliable solder joint.

There are several types of SMT reflow technologies currently used in the industry. These surface-mount power modules can be adequately soldered using natural convection, IR (radiant infrared), convection/IR, or forced convection technologies. The surface-mount power module solder reflow profile is established by accurately measuring the module gull-wing lead surface temperature.

Surface-Mount Power Module Solder Reflow Recommendation (continued)

The maximum oven temperature and conveyor speed should prevent the lead temperature from exceeding the maximum thermal profile limits as shown in Figure 18. The lead temperature during a typical reflow profile is shown in Figure 19. Failure to observe these maximum lead temperatures and duration may result in permanent damage to the power module.

Relative temperatures of the module gull-wing leads vary according to many factors, including surrounding components, internal paths, and connecting paths. Typically, pin 1 is a good choice for a conservative measurement since it is usually connected to heavy paths for current conduction which also tend to heat the lead faster. These variables make it difficult to compare various types of surface-mount modules; however, based upon a sampling, the Lucent Technologies unit has been found to be more robust during temperature profiles compared with other SMT modules available in the industry at the time of this publication.

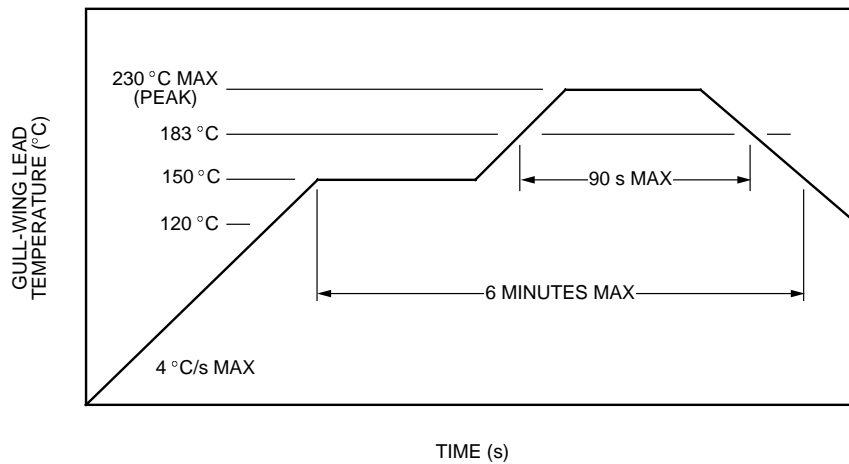

8-2275(C)

Figure 18. Maximum Thermal Profile Limits

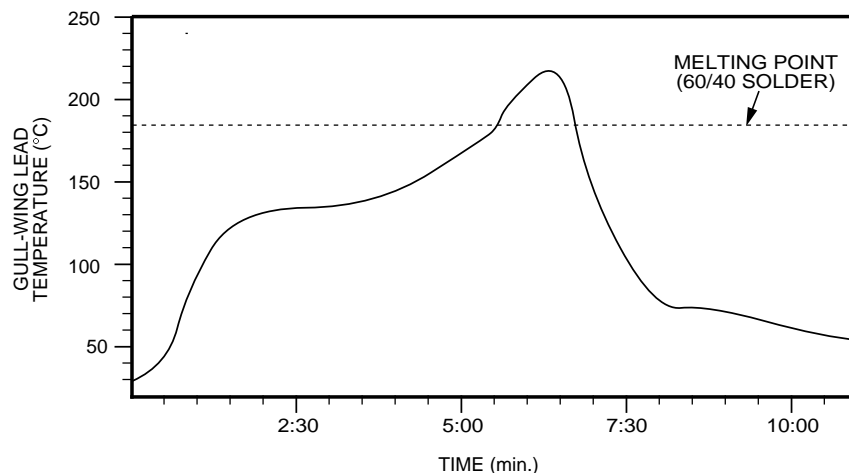

8-2274(C).a

Figure 19. Typical Reflow Soldering Profile

Packaging Information

Vacuum Formed Trays

The SMC/SMW-Series surface-mount power modules are delivered in plastic vacuum formed trays (see Figure 20) that allow automated placement of the modules via a surface-mount pick and place machine.

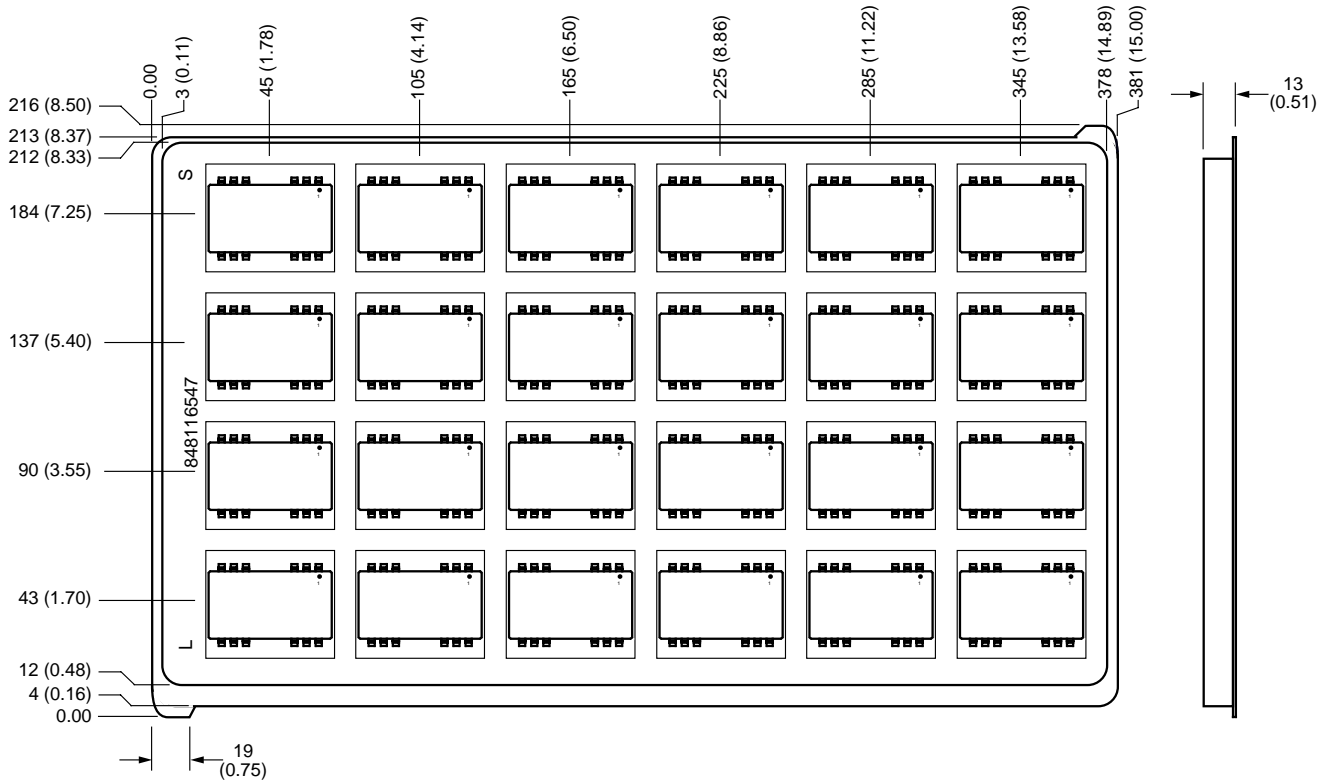

8-2263(C)

Note: Dimensions are in millimeters and (inches).

Figure 20. Vacuum Formed Tray

Specifications:

- Material: PVC (ESD protected)
- Capacity: 24 pieces/tray
- Weight: 90 g (3.2 oz.)

Outline Diagram

Dimensions are in millimeters and (inches). See next page for pin descriptions.
Tolerances: $x.x \pm 0.5$ mm (0.020 in.); $x.xx \pm 0.4$ mm (0.015 in.).

Top View

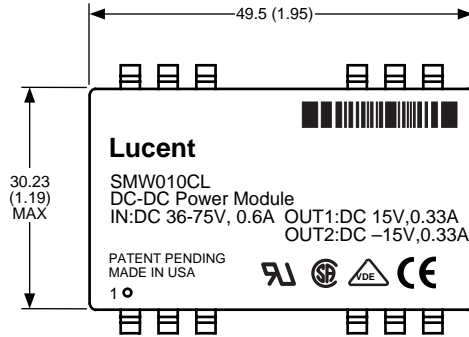

Side Views

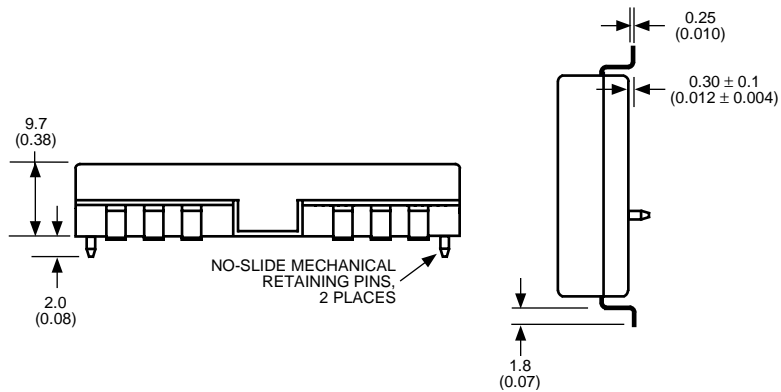

Bottom View

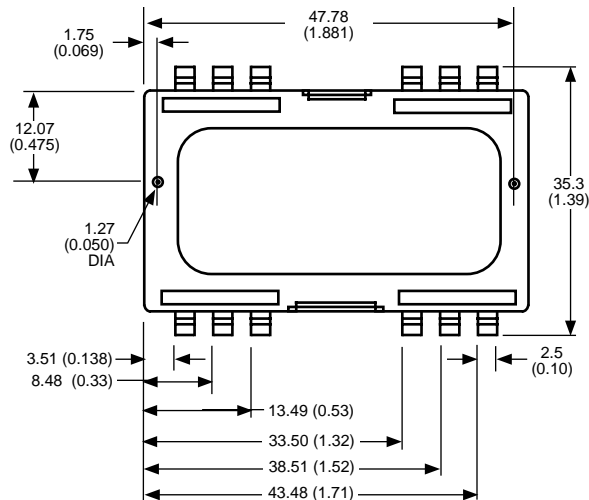

8-1507(C).e

Recommended Hole Pattern

Component-side footprint. Dimensions are in millimeters and (inches).
Tolerances: $x.x \pm 0.5$ mm (0.020 in.); $x.xx \pm 0.4$ mm (0.015 in.).

CAUTION: Care must be taken to ensure the board in the periphery of the footprint is flat.

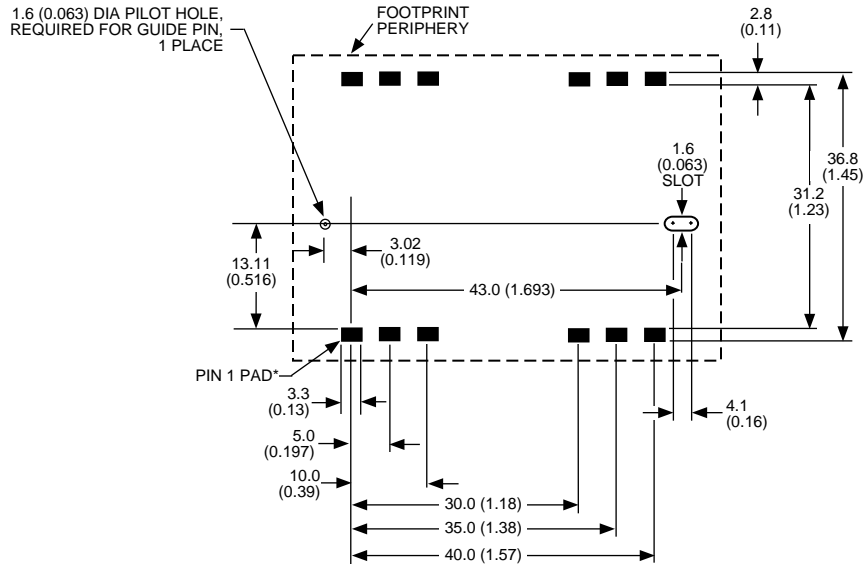

8-1507(C).e

Pin	Function	Pin	Function
1	$V_{O1}(+)$	12	$V_I(+)$
2	COM	11	$V_I(-)$
3	$V_{O2}(-)$	10	N/C†
4	TRIM	9	SYNC (optional)
5	N/C†	8	ON/OFF
6	N/C†	7	TURN-ON ADJUSTMENT (optional)

* The recommended solder paste volume is 2.8 cubic mm (170,000 cubic mils/pin). See Design Considerations section.

† N/C may be used for internal module connections and should not be connected by the customer.

Ordering Information

Table 6. Device Codes

Input Voltage	Output Voltages	Output Power	Device Code	Comcode
24 V	5 V, -5 V	10 W	SMC010AJ*	TBD
24 V	12 V, -12 V	10 W	SMC010BK*	TBD
24 V	15 V, -15 V	10 W	SMC010CL*	TBD
48 V	5 V, -5 V	10 W	SMW010AJ	108611047
48 V	12 V, -12 V	10 W	SMW010BK	108729781
48 V	15 V, -15 V	10 W	SMW010CL	108560954

* SMC codes are available upon request only. Contact the factory for minimum order size and availability.

Optional features may be ordered using the device code suffixes shown below. The feature suffixes are listed numerically in descending order. Please contact your Lucent Technologies Account Manager or Application Engineer for pricing and availability of options.

Table 7. Device Options

Option	Device Code Suffix
Negative logic remote on/off	1

Notes

Notes

For additional information, contact your Lucent Technologies Account Manager or the following:

POWER SYSTEMS UNIT: Network Products Group, Lucent Technologies Inc., 3000 Skyline Drive, Mesquite, TX 75149, USA

+1-800-526-7819 (Outside U.S.A.: +1-972-284-2626, FAX +1-888-315-5182) (product-related questions or technical assistance)

INTERNET: <http://www.lucent.com/networks/power>

E-MAIL: techsupport1@lucent.com

ASIA PACIFIC: Lucent Technologies Singapore Pte. Ltd., 750D Chai Chee Road #07-06, Chai Chee Industrial Park, Singapore 469004

Tel. (65) 240 8041, FAX (65) 240 8438

CHINA: Lucent Technologies (China) Co. Ltd., SCITECH Place No. 22, Jian Guo Men Wai Avenue, Beijing 100004, PRC

Tel. (86) 10-6522 5566 ext. 4187, FAX (86) 10-6512 3634

JAPAN: Lucent Technologies Japan Ltd., Mori Building No. 21, 4-33, Roppongi 1-Chome, Minato-ku, Tokyo 106-8508, Japan

Tel. (81) 3 5561 5831, FAX (81) 3 5561 1616

LATIN AMERICA: Lucent Technologies Inc., Room 416, 2333 Ponce de Leon Blvd., Coral Gables, FL 33134, USA

Tel. +1-305-569-4722, FAX +1-305-569-3820

EUROPE: Data Requests: DATALINE: Tel. (44) 7000 582 368, FAX (44) 1189 328 148

Technical Inquiries: GERMANY: (49) 89 95086 0 (Munich), UNITED KINGDOM: (44) 1344 865 900 (Ascot),

FRANCE: (33) 1 40 83 68 00 (Paris), SWEDEN: (46) 8 594 607 00 (Stockholm), FINLAND: (358) 9 4354 2800 (Helsinki),

ITALY: (39) 02 6608131 (Milan), SPAIN: (34) 91 807 1441 (Madrid)

Lucent Technologies Inc. reserves the right to make changes to the product(s) or information contained herein without notice. No liability is assumed as a result of their use or application. No rights under any patent accompany the sale of any such product(s) or information.

