

# SMX-1SHF MESA

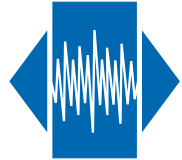

## High frequency fundamental SMD Crystal

### Features

- Applications: telecommunications, audio, navigation, instruments
- Wide frequency range: 60 to 200 MHz in the fundamental mode
- High pulling sensitivity (ppm/pF)
- Reflow soldering @ 260 °C

Parameter	Specification	
Frequency range	60 ~ 200 MHz	fundamental
Mode of oscillation	AT-cut	
Standard frequencies	76.80, 122.88, 155.52, 156.25, 159.375 & 180.00 MHz	
Frequency tolerance	±10 ~ ±30 ppm	@ +25 °C
Frequency stability	±10 ~ ±50 ppm	vs. operating temperature range
Aging	±2 ppm	1st year
Load capacitance	series or parallel resonance (CL = 8 ~ 32 pF)	
Equivalent series resistance (ESR)	30 Ω	for 60 ~ 200 MHz
Drive level	10 ~ 100 μW	
Operating temperature range	-20 ~ +70 °C -40 ~ +85 °C	commercial application Industrial application
Storage temperature range	-55 ~ +125 °C	
Packaging unit	tape & reel	1'000 or 2'000 pieces
Customer specifications on request		

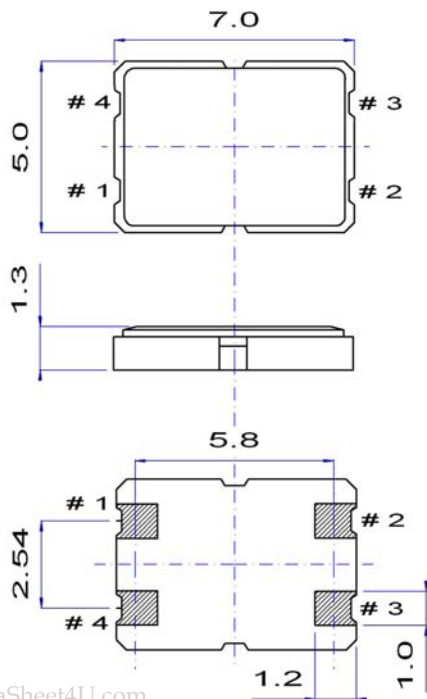

### Pin function

- # 1 crystal connection
- # 2 GND
- # 3 crystal connection
- # 4 GND

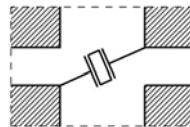

### Example for soldering pattern

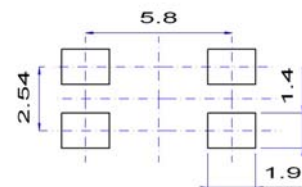

**Do not design any conductive path between the pattern**

### Example for IR reflow soldering temperature

