

REV.	ECN. NO.	NAME	DATE

A
B
C
D
E
F

A
B
C
D
E
F

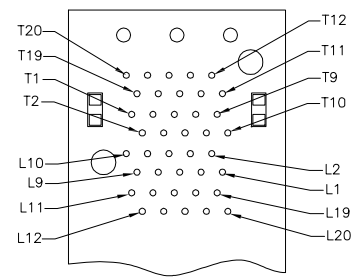
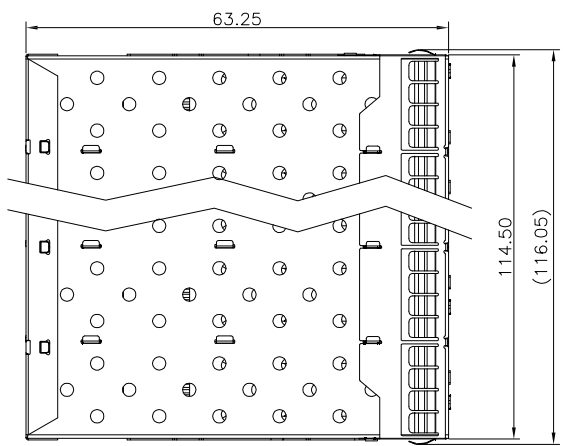

CONNECTOR PIN-OUT
COMPONENT SIDE OF BOARD

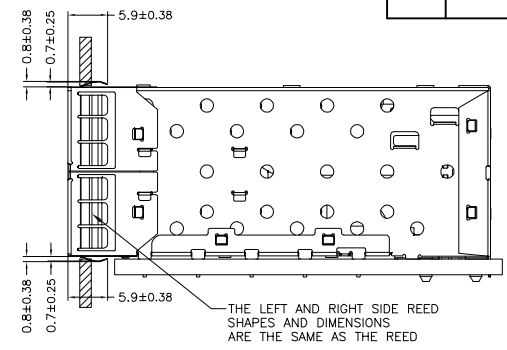

THE LEFT AND RIGHT SIDE REED
SHAPES AND DIMENSIONS
ARE THE SAME AS THE REED

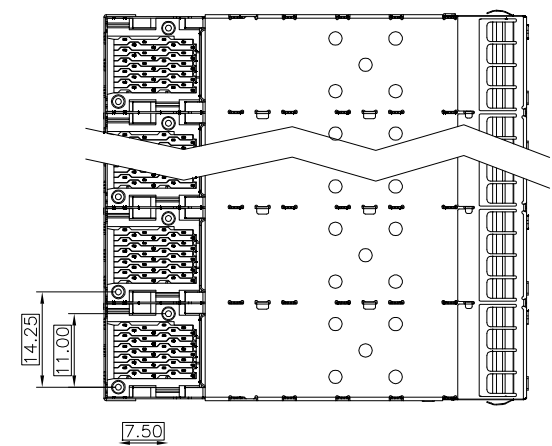
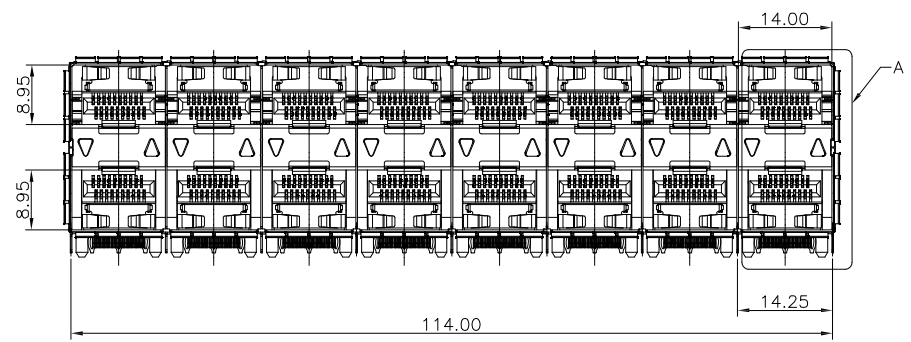
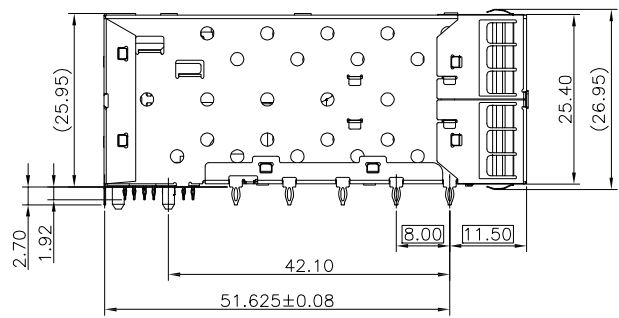

NOTES:
MATERIAL:
CAGE: COPPER ALLOY
CONNECTOR:
PLASTIC HOUSING: HIGH TEMPERATURE LCP, UL94 V-0.
LIGHT PIPE: POLYCARBONATE; COLOR: CLEAR
SPRING: STAINLESS STEEL
CONTACTS: PHOSPHOR BRONZE
CONTACT PLATING: 15u" MIN. GOLD ON MATING AREA,
150u" MATTE TIN ON SOLDER TAILS
PACKAGING: TRAY PACKAGING.
OPERATING TEMPERATURE: -40°C TO +85°C
STORAGE TEMPERATURE: -55°C TO +105°C

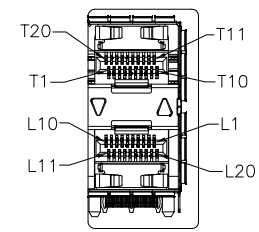

DETAIL A 1:1

TOLERANCE UNSPECIFIED		 a vital connector company		FOR YOUR VITAL CONNECTION	
.0	± 0.38				
.00	± 0.25	TITLE: SFP+2*8 CAGE+CONN			
.000	± 0.10				
ANGLE	± 3.00°	DRAWN BY: BECKER		PART NO: SN28B	
MANUFACTURING COPY		CHECKED BY: VTA		REV: A	
		APPROVED BY: QPF		SIZE: A4	
		PROJECTION		UNIT: mm	
				SHEET: 10F3	
				FCN: A4	
				http://www.vitalconn.com	

RoHS Compliant

1 2 3 4 5 6 7 8

REV.	ECN. NO.	NAME	DATE

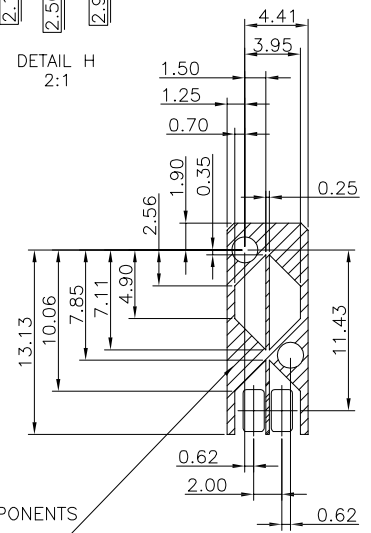
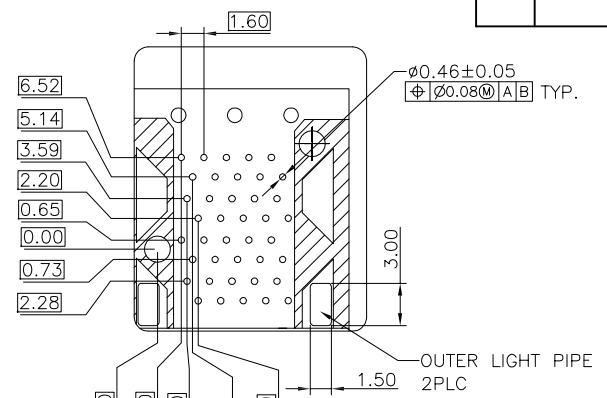
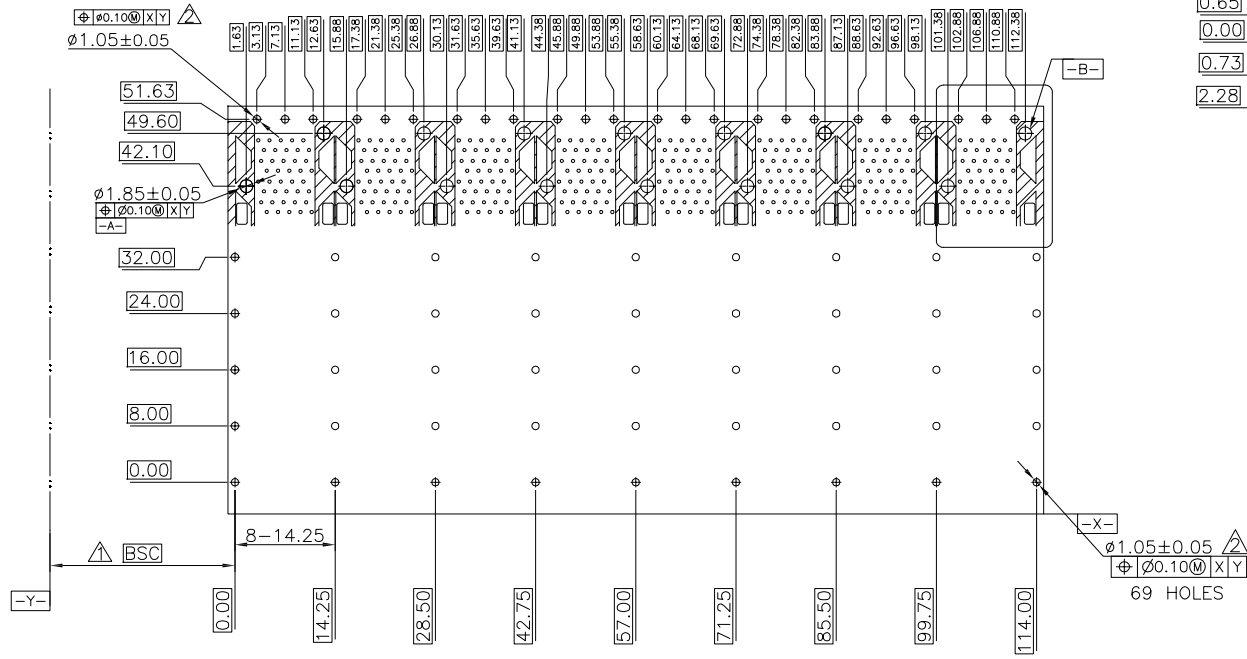

THE ENTIRE AREA OF THE CONNECTOR FOOTPRINT TO BE CONSIDERED THE KEEP OUT AREA FOR COMPONENTS (OTHER THAN LIGHT PIPE LE'S) THIS AREA IS INDICATED BY THE DASHED LINE

- NOTES:
1. DATUM AND BASIC DIMENSIONS ESTABLISHED BY CUSTOMER.
 2. 1.05 mm DIAMETER HOLES ARE CHASSIS GROUND.

RoHS Compliant

TOLERANCE UNSPECIFIED		 VITALCONN a vital connector company		FOR YOUR VITAL CONNECTION			
.0	± 0.38						
.00	± 0.25	TITLE: SFP+2*8 CAGE+CONN					
.000	± 0.10						
ANGLE	± 3.00°	DRAWN BY:	BECKER	PART NO:	SN28B	REV: A	
MANUFACTURING COPY		CHECKED BY:	VTA	SIZE: A4	UNIT: mm	SHEET: 20F3	FCN: A4
		APPROVED BY:	QPF	PROJECTION		http://www.vitalconn.com	

REV.	ECN. NO.	NAME	DATE

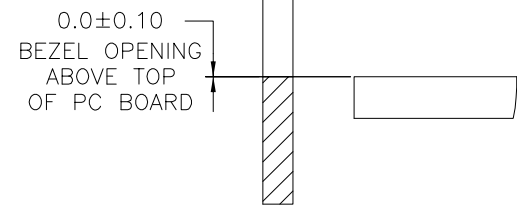
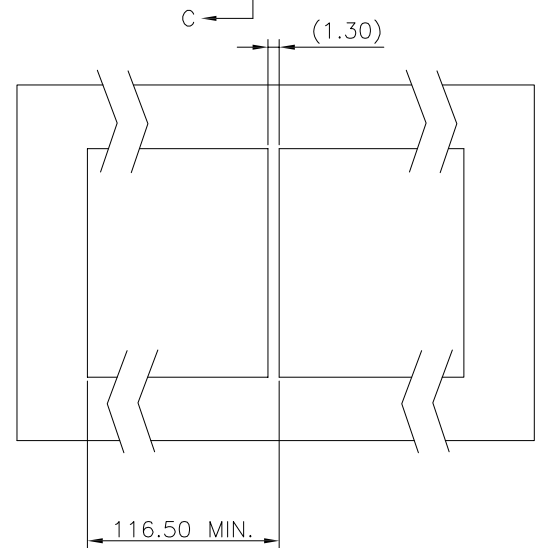
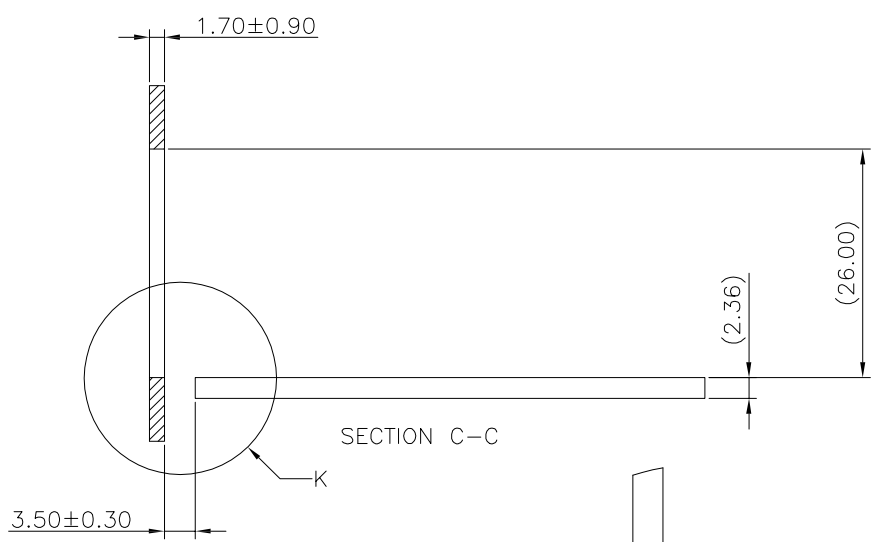
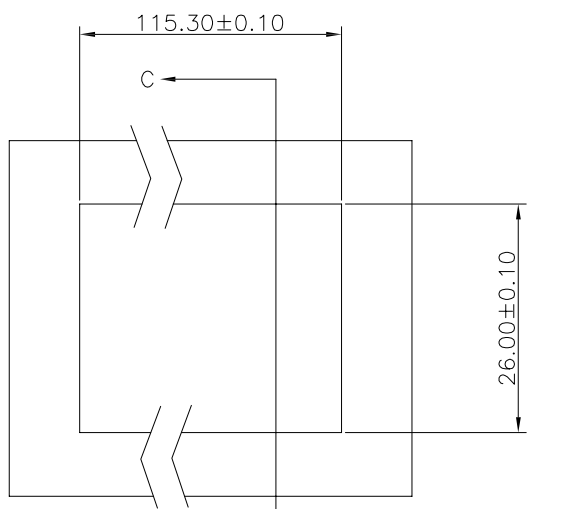

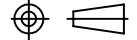
TOLERANCE UNSPECIFIED		 a vital connector company		FOR YOUR VITAL CONNECTION	
.0	± 0.38			TITLE: SFP+2*8 CAGE+CONN	
.00	± 0.25	DRAWN BY:	BECKER	PART NO:	SN28B
.000	± 0.10	CHECKED BY:	VTA	SIZE: A4	UNIT: mm
ANGLE	± 3.00°	APPROVED BY:	QPF	PROJECTION	SHEET:30F3
MANUFACTURING COPY				 http://www.vitalconn.com	

RoHS Compliant