

18V LED driver with internal switch

General Description

The SN3340 is a continuous mode inductive step-down converter, designed for driving a single LED or multiple series connected LEDs efficiently from a voltage source higher than the required LED voltage. The chip operates from an input supply between 6V and 18V and provides an externally adjustable output current of up to 750mA. Depending upon supply voltage and external components, this can provide up to 12 watts of output power.

The SN3340 includes an integrated switch and a high-side output current sensing circuit, which uses an external resistor to set the nominal average output current.

Output current can be adjusted linearly by applying an external control signal to the ADJ pin. The ADJ pin will accept either a DC voltage or a PWM waveform. This will provide either a continuous or a gated output current.

Applying a voltage of 0.2V or lower to the ADJ pin turns the output off and switches the chip into a low current standby state.

The chip is assembled in SOT23-5 and SOT89-5 package. SOT23-5 is available for 350mA output current application; SOT89-5 is available for 700mA output current application.

Application Circuit

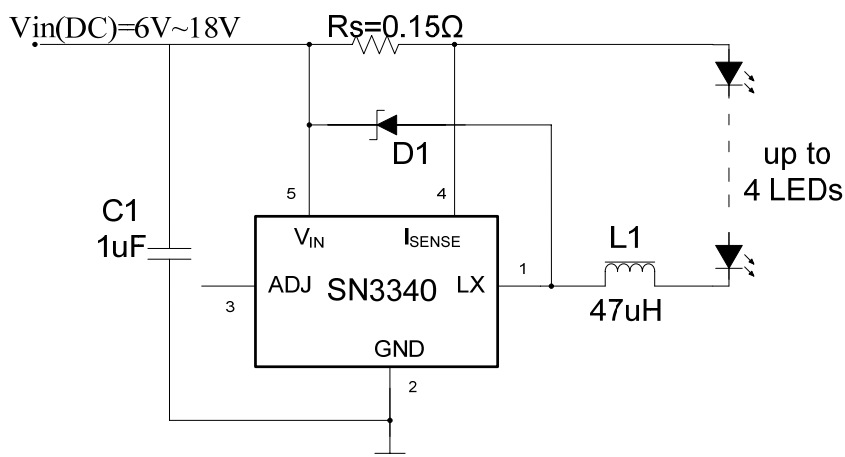

Features

- Simple low parts count
- input voltage range: 6V to 18V , 30V transient capability
- Internal 18V power switch
- Up to 750mA output current (SOT89-5 package)
- Single pin on/off and brightness control using DC voltage or PWM
- High efficiency (up to 95%)
- Up to 1MHz switching frequency
- Inherent open-circuit LED protection
- Thermal shutdown protection circuitry

Applications

- High Power LED Driver
- Automotive Lighting
- White LED Lamps
- Constant-Current Source

Pin Configurations

| Package | Pin Configurations |
|---------|--------------------|
| SOT23-5 | |
| SOT89-5 | |

Pin Description

| Pin Name | NO. | Description |
|-------------|-----|---|
| LX | 1 | Drain of power switch |
| GND | 2 | Ground (0V) |
| ADJ | 3 | Multi-function On/Off and brightness control pin: * Leave floating for normal operation. ($V_{ADJ} = V_{REF} = 1.2V$ giving nominal average output current $I_{OUT\ nom} = 0.1/R_S$) * Drive to voltage below 0.2V to turn off output current * Drive with DC voltage ($0.3V < V_{ADJ} < 1.2V$) to adjust output current from 25% to 100% of $I_{OUT\ nom}$ * Drive with PWM signal to adjust output current. * When driving the ADJ pin above 1.2V, the current will be set to 100% brightness automatically. |
| I_{SENSE} | 4 | Connect resistor R_S from this pin to V_{IN} to define nominal average output current $I_{OUT\ nom} = 0.1/R_S$ |
| V_{IN} | 5 | Input voltage (6V to 18V). Decouple to ground with $1\mu F$ or higher X7R ceramic capacitor close to device |

Ordering information

| Order Number | Quantity per reel | Operating Temperature Range |
|--------------|-------------------|-----------------------------|
| SN3340IS05E | 3,000 | -40 °C to 85°C |
| SN3340IP05E | 2,500 | -40 °C to 85°C |

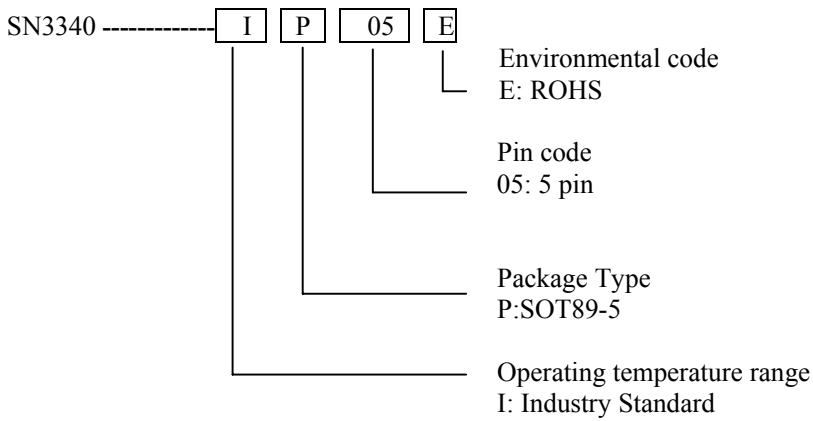
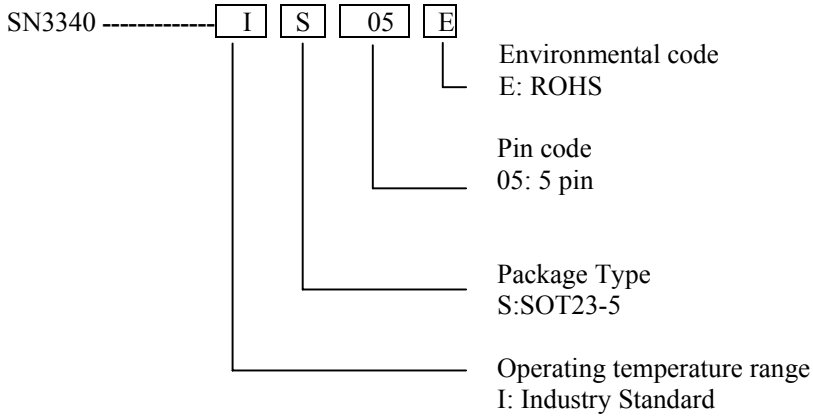

Absolute maximum ratings

| Symbol | Parameter | Rating |
|---------------------|----------------------------|---|
| V _{IN} | Input voltage | -0.3V to +20V (30V transient capability) |
| V _{ISENSE} | I _{SENSE} voltage | V _{IN} +0.3V to V _{IN} -5V, V _{IN} >5V |
| | | V _{IN} +0.3V to -0.3V, V _{IN} <5V |
| V _{LX} | LX output voltage | -0.3V to +20V |
| V _{ADJ} | Adjust pin input voltage | -0.3V to +6V |
| I _{LX} | Switch output current | 800mA@SOT89-5;400mA@ SOT23-5 |
| P _{tot} | Power dissipation | 1.2W @SOT89-5;600mW@SOT23-5 |
| T _{OP} | Operating temperature | -40 to 105°C |
| T _{ST} | Storage temperature | -55 to 150°C |
| T _{JMAX} | Junction temperature | 150°C |
| R _{θJA} | Junction to ambient | 200°C/W @SOT23-5; 45°C/W @SOT89-5 |
| ESD | (human body mode | 2KV |

Electrical characteristics (test conditions: V_{IN}=12V, T_{amb}=25°C unless otherwise stated) (*)

| Symbol | Parameter | Conditions | Min. | Typ. | Max. | Unit |
|-----------------------|--|--|------|------|------|------|
| V _{IN} | Input voltage | | 6 | | 18 | V |
| I _{INQoff} | Quiescent supply current with output off | ADJ pin grounded | 40 | 60 | 80 | μA |
| I _{INQon} | Quiescent supply current with output switching | ADJ pin floating | | 450 | 600 | μA |
| V _{ISENSE} | Mean current sense threshold voltage | Measured on I _{SENSE} pin with respect to V _{IN} ADJ pin floating | 91 | 100 | 110 | mV |
| V _{SENSEHYS} | Sense threshold hysteresis | | | ±15 | | % |
| I _{SENSE} | I _{SENSE} pin input current | V _{SENSE} = 0.1V | | 8 | 10 | μA |
| V _{REF} | Internal reference voltage | Measured on ADJ pin with pin floating | | 1.2 | | V |
| V _{ADJ} | External control voltage range on ADJ pin for dc brightness control | | 0.3 | | 1.2 | V |
| V _{ADJoff} | DC voltage on ADJ pin to switch chip from active (on) state to quiescent (off) state | V _{ADJ} falling | 0.15 | 0.2 | 0.25 | V |
| V _{ADJon} | DC voltage on ADJ pin to switch chip from quiescent (off) state to active (on) state | V _{ADJ} rising | 0.2 | 0.25 | 0.3 | V |
| R _{ADJ} | Resistance between ADJ pin and V _{REF} | | | 500 | | KΩ |
| I _{LXmean} | Continuous LX switch current | SOT23-5 package | | 0.35 | | A |
| | | SOT89-5 package | | 0.65 | | |
| R _{LX} | LX Switch 'On' resistance | | | 0.9 | 1.5 | Ω |

Electrical characteristics (test conditions: $V_{IN}=12V$, $T_{amb}=25^{\circ}C$ unless otherwise stated) (*) (continued)

| Symbol | Parameter | Conditions | Min. | Typ. | Max. | Unit |
|----------------|--|---|------|--------|------|-------------|
| $I_{LX(leak)}$ | LX switch leakage current | | | | 1 | μA |
| $D_{PWM(LF)}$ | Brightness control range at low frequency PWM signal | PWM frequency =100Hz PWM amplitude=5V, $V_{in}=15V$, $L=27\mu H$, Driving 1 LED | | 1200:1 | | |
| $D_{PWM(HF)}$ | Brightness control range at high frequency PWM signal | PWM frequency =10KHz PWM amplitude=5V, $V_{in}=15V$, $L=27\mu H$, Driving 1 LED | | 13:1 | | |
| f_{LX} | Operating frequency | ADJ pin floating $L=100\mu H$ (0.82 Ω) $I_{OUT}=350mA$ @ $V_{LED}=3.4V$ Driving 1 LED | | 154 | | KHz |
| T_{ONmin} | Minimum switch 'ON' time | LX switch 'ON' | | 200 | | ns |
| T_{OFFmin} | Minimum switch 'OFF' time | LX switch 'OFF' | | 200 | | ns |
| f_{LXmax} | Recommended maximum operating frequency | | | | 1 | MHz |
| D_{LX} | Recommended duty cycle range of output switch at f_{LXmax} | | 0.3 | 0.7 | 0.9 | |
| T_{PD} | Internal comparator propagation delay | | | 50 | | ns |
| T_{SD} | Thermal shutdown temperature | | | 140 | | $^{\circ}C$ |
| T_{SD-HYS} | Thermal shutdown hysteresis | | | 20 | | $^{\circ}C$ |

NOTES:

(*) Production testing of the chip is performed at 25°C. Functional operation of the chip and parameters specified are guaranteed by design, characterization and process control .in other temperature.

Typical operating conditions

For typical application circuit and $T_{amb}=25^{\circ}\text{C}$ unless otherwise stated.

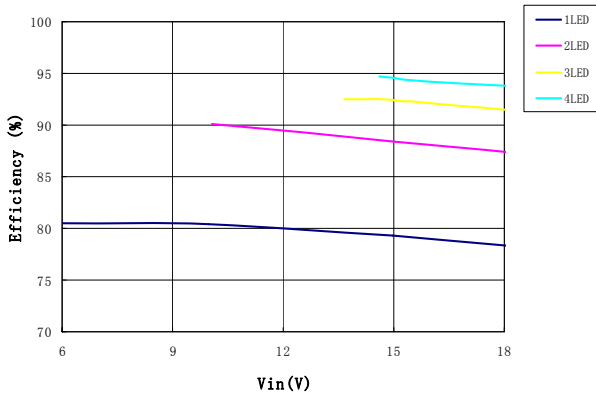

Efficiency vs. No. of LEDs
L=100uH, Rs=0.33Ohm

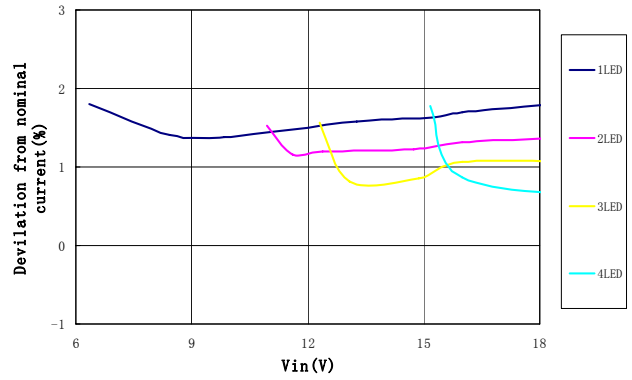

Output current variation with Supply Voltage
L=100uH, Rs=0.33Ohm

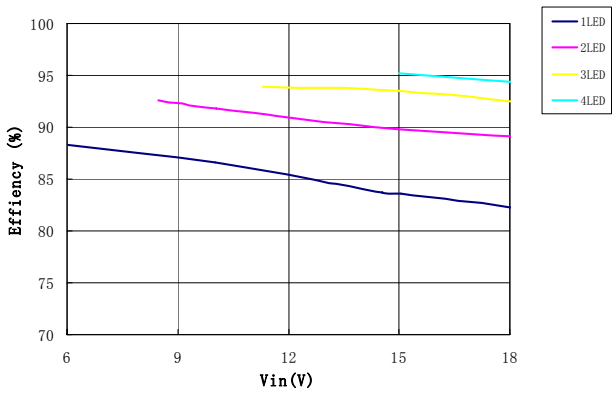

Efficiency vs. No. of LEDs
L=47uH, Rs=0.33Ohm

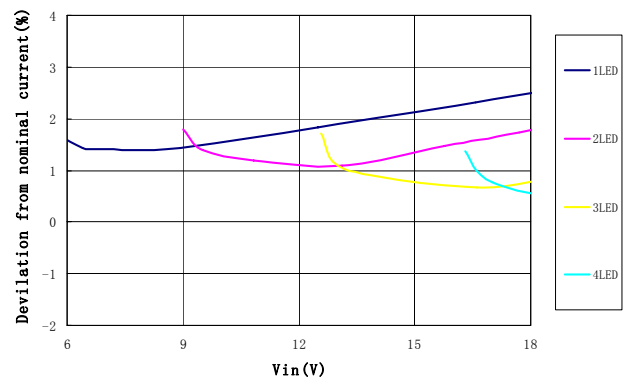

Output current variation with Supply Voltage
L=47uH, Rs=0.33Ohm

Typical operating conditions (continued)

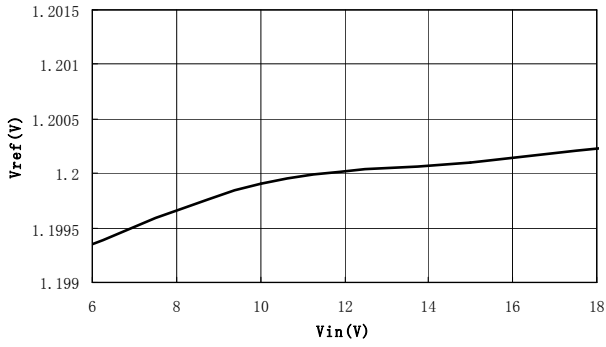

Vref vs. Vin over nominal supply voltage range

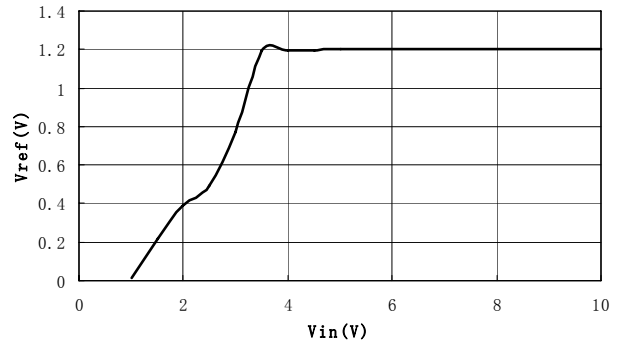

Vref vs. Vin at low supply voltage

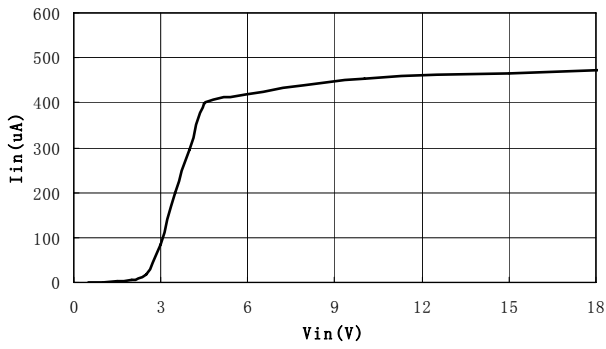

Supply Current vs. Vin (Operating)

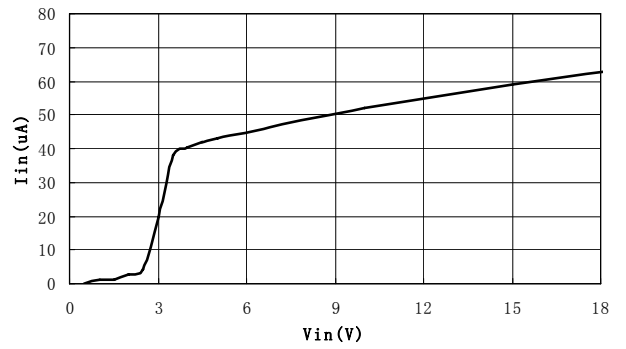

Supply Current vs. Vin (Quiescent)

Application notes

Setting nominal average output current with external resistor R_S

The nominal average output current in the LED(s) is determined by the value of the external current sense resistor (R_S) connected between V_{IN} and I_{SENSE} and is given by:

$$I_{OUT\ nom} = 0.1/R_S \text{ [for } R_S > 0.13\Omega\text{]}$$

The table below gives values of nominal average output current for several preferred values of current setting resistor (R_S) in the typical application circuit shown on page 1:

| R_S (Ω) | Nominal average output current (mA) |
|--------------------|-------------------------------------|
| 0.13 | 769 |
| 0.15 | 667 |
| 0.27 | 370 |
| 0.3 | 333 |

The above values assume that the ADJ pin is floating and at a nominal voltage of $V_{REF} = 1.2V$.

Note that $R_S = 0.13\Omega$ is the minimum allowed value of sense resistor under these conditions to maintain switch current below the specified maximum value.

It is possible to use different values of R_S if the ADJ pin is driven from an external voltage.

Output current adjustment by external DC control voltage

The ADJ pin can be driven by an external dc voltage (V_{ADJ}), as shown, to adjust the output current to a value above or below the nominal average value defined by R_S .

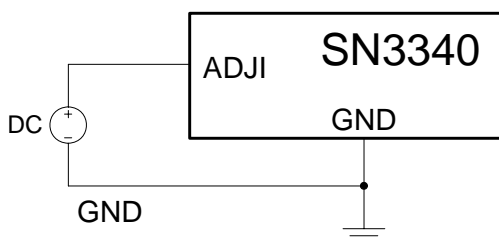

The nominal average output current in this case is given by:

$$I_{OUTdc} = 0.083 * V_{ADJ} / R_S \text{ [for } 0.3V < V_{ADJ} < 1.2V\text{]}$$

Note that 100% brightness setting corresponds to $V_{ADJ} = V_{REF}$. When driving the ADJ pin above 1.2V, the current will be clamped to 100% brightness automatically.

The input impedance of the ADJ pin is $500k\Omega \pm 25\%$.

Output current adjustment by PWM control

Directly driving ADJ input

A Pulse Width Modulated (PWM) signal with duty cycle D_{PWM} can be applied to the ADJ pin, as shown below, to adjust the output current to a value below the nominal average value set by resistor R_S , the signal range is from 0V~5V. The PWM signal must have the driving ability to drive internal $500k\Omega$ pull-up resistor.

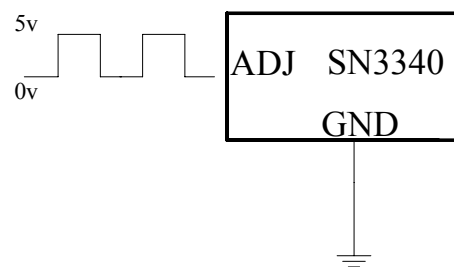

Driving the ADJ input from a microcontroller

Another possibility is to drive the chip from the open drain output of a microcontroller. The diagram below shows one method of doing this:

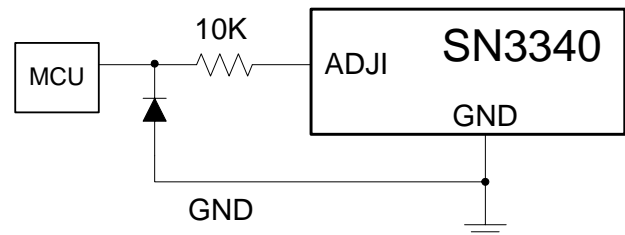

The diode and resistor suppress possible high amplitude negative spikes on the ADJ input resulting from the drain-source capacitance of the FET. Negative spikes at the input to the chip should be avoided as they may cause errors in output current or erratic device operation.

Shutdown mode

Taking the ADJ pin to a voltage below 0.2V will turn off the output and supply current will fall to a low standby level of $60\mu A$ nominal.

Inherent open-circuit LED protection

If the connection to the LED(s) is open-circuited, the coil is isolated from the LX pin of the chip, so the chip will not be damaged, unlike in many boost converters, where the back EMF may damage the internal switch by forcing the drain above its breakdown voltage.

Capacitor selection

A low ESR capacitor should be used for input decoupling, as the ESR of this capacitor appears in series with the

supply source impedance and lowers overall efficiency. This capacitor has to supply the relatively high peak current to the coil and smooth the current ripple on the input supply.

If the source is DC supply, the capacitor is decided by ripple of the source, the value is given by:

$$C_{\min} = \frac{I_F * T_{on}}{\Delta U_{MAX}}$$

I_F is the value of output current, ΔU_{MAX} is the ripple of power supply. T_{on} is the "ON" time of MOSFET

the value is normally 2 times of the minimum value.

If the source is an AC supply, typical output voltages ripple from a nominal 12V AC transformer can be $\pm 10\%$. If the input capacitor value is lower than 200 μ F, the AC input waveform is distorted, sometimes the lowest value will be lower than the forward voltage of LED strings. This lower the average current of the LEDs. So a more than 200 μ F capacitor is recommended.

For maximum stability over temperature and voltage, capacitors with X7R, X5R, or better dielectric are recommended. Capacitors with Y5V dielectric are not suitable for decoupling in this application and should not be used.

Inductor selection

Recommended inductor values for the SN3340 are in the range 47 μ H to 220 μ H.

Higher values of inductance are recommended at higher supply voltages and low output current in order to minimize errors due to switching delays, which result in increased ripple and lower efficiency. Higher values of inductance also result in a smaller change in output current over the supply voltage range. (See graphs). The inductor should be mounted as close to the chip as possible with low resistance connections to the LX and V_{IN} pins.

The chosen coil should have a saturation current higher than the peak output current and a continuous current rating above the required mean output current. It is recommended to use inductor with saturation current bigger than 1.2A for 700mA output current and inductor with saturation current bigger than 500mA for 350mA output current.

The inductor value should be chosen to maintain operating duty cycle and switch 'on/off' times within the specified limits over the supply voltage and load current range.

The following equations can be used as a guide.

LX Switch 'On' time

$$T_{ON} = \frac{L\Delta I}{V_{IN} - V_{LED} - I_{AVG}(R_S + r_L + R_{LX})}$$

Note: $T_{ONmin} > 200ns$

LX Switch 'Off' time

$$T_{OFF} = \frac{L\Delta I}{V_{LED} + V_D + I_{AVG}(r_L + R_S)}$$

Note: $T_{OFFmin} > 200ns$

Where:

L is the coil inductance (H)

r_L is the coil resistance (Ω)

I_{avg} is the required LED current (A)

ΔI is the coil peak-peak ripple current (A) {Internally set to $0.3 \times I_{avg}$ }

V_{IN} is the supply voltage (V)

V_{LED} is the total LED forward voltage (V)

R_{LX} is the switch resistance (Ω)

V_D is the diode forward voltage at the required load current (V)

Example:

For $V_{IN}=12V$, $L=47\mu H$, $r_L=0.64\Omega$, $V_{LED}=3.4V$, $I_{avg}=350mA$ and $V_D=0.36V$

$$T_{ON} = (47e-6 \times 0.105)/(12 - 3.4 - 0.612) = 0.62\mu s$$

$$T_{OFF} = (47e-6 \times 0.105)/(3.4 + 0.36 + 0.322) = 1.21\mu s$$

This gives an operating frequency of 546kHz and a duty cycle of 0.34.

These and other equations are available as a spreadsheet calculator from SI-EN distributor.

Optimum performance will be achieved by setting the duty cycle close to 0.5 at the nominal supply voltage. This helps to equalize the undershoot and overshoot and improves temperature stability of the output current.

Diode selection

For maximum efficiency and performance, the rectifier (D1) should be a fast low capacitance Schottky diode with low reverse leakage at the maximum operating voltage and temperature.

If alternative diodes are used, it is important to select parts with a peak current rating above the peak coil current and a continuous current rating higher than the maximum output load current. It is very important to consider the reverse leakage of the diode when operating above 85°C. Excess leakage will increase the power dissipation in the device.

The higher forward voltage and overshoot due to reverse recovery time in silicon diodes will increase the peak voltage on the LX output. If a silicon diode is used, care should be taken to ensure that the total voltage appearing on the LX pin including supply ripple, does not exceed the specified maximum value.

Reducing output ripple

Peak to peak ripple current in the LED can be reduced, if required, by shunting a capacitor C_{led} across the LED(s) as shown below:

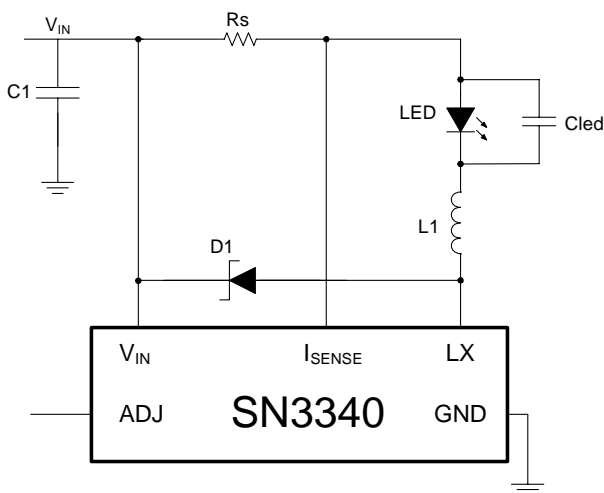

A value of $1\mu\text{F}$ will reduce nominal ripple current by a factor three (approx.). Proportionally lower ripple can be achieved with higher capacitor values. Note that the capacitor will not affect operating frequency or efficiency, but it will increase start-up delay, by reducing the rate of rise of LED voltage.

Operation at low supply voltage

The internal regulator disables the drive to the switch until the supply has risen above the startup threshold set internally which makes power MOSFET on-resistance small enough. Above this threshold, the chip will start to operate. However, with the supply voltage below the specified minimum value, the switch duty cycle will be high and the chip power dissipation will be at a maximum. Care should be taken to avoid operating the chip under such conditions in the application, in order to minimize the risk of exceeding the maximum allowed die temperature. (See next section on thermal considerations).

Note that when driving loads of two or more LEDs, the forward drop will normally be sufficient to prevent the chip from switching below approximately 6V. This will minimize the risk of damage to the chip.

Thermal considerations

When operating the chip at high ambient temperatures, or when driving maximum load current, care must be taken to avoid exceeding the package power dissipation limits. Two packages are available for different application because of thermal consideration. SOT23-5 is only available for 350mA current output application. The SOT89-5 package's thermal resistance is much lower so that it can handle 700mA current and suitable for 700mA application.

Note that the chip power dissipation will most often be a maximum at minimum supply voltage. It will also increase if the efficiency of the circuit is low. This may result from the use of unsuitable coils, or excessive parasitic output capacitance on the switch output.

Layout considerations

LX pin

The LX pin of the chip is a fast switching node, so PCB traces should be kept as short as possible. To minimize ground 'bounce', the ground pin of the chip should be soldered directly to the ground plane.

Coil and decoupling capacitors

It is particularly important to mount the coil and the input decoupling capacitor close to the chip to minimize parasitic resistance and inductance, which will degrade efficiency. It is also important to take account of any trace resistance in series with current sense resistor R_s .

ADJ pin

The ADJ pin is a high impedance input, so when left floating, PCB traces to this pin should be as short as possible to reduce noise pickup. ADJ pin can also be connected to a voltage between 1.2~5V. In this case, the internal circuit will clamp the output current at the value which is set by $ADJ=1.2V$.

High voltage traces

Avoid running any high voltage traces close to the ADJ pin, to reduce the risk of leakage due to board contamination. Any such leakage may raise the ADJ pin voltage and cause excessive output current. A ground ring placed around the ADJ pin will minimize changes in output current under these conditions.

Package Information

SOT23-5

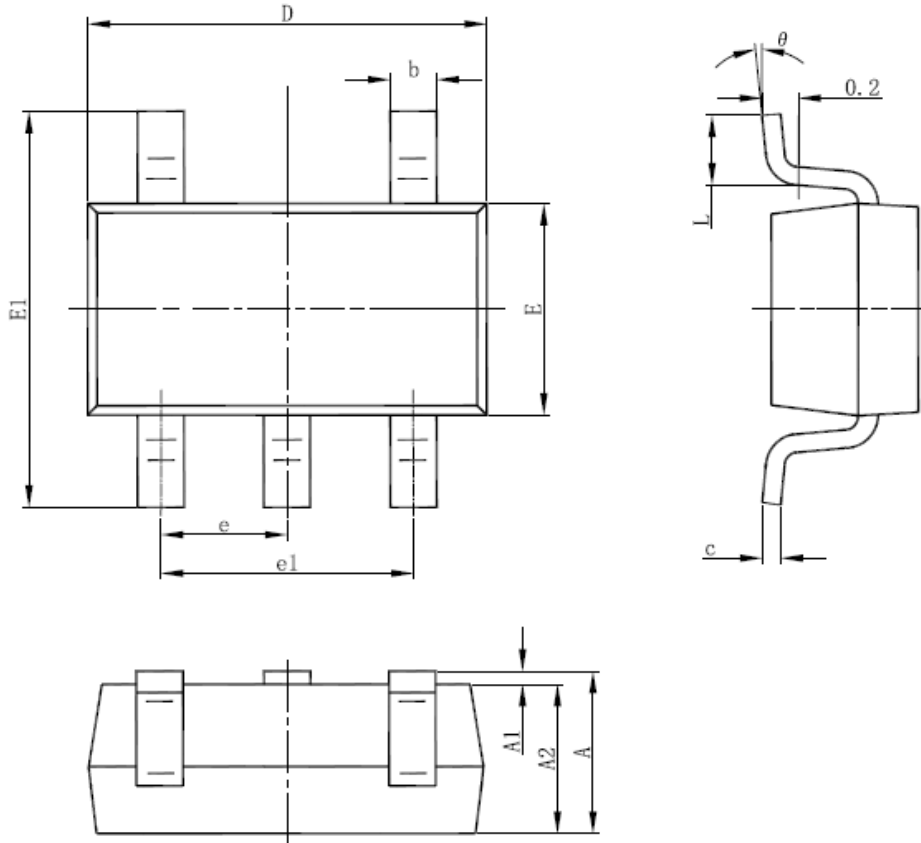

| Symbol | Dimensions In Millimeters | | Dimensions In Inches | |
|----------|---------------------------|-------|----------------------|-------|
| | Min | Max | Min | Max |
| A | 1.050 | 1.250 | 0.041 | 0.049 |
| A1 | 0.000 | 0.100 | 0.000 | 0.004 |
| A2 | 1.050 | 1.150 | 0.041 | 0.045 |
| b | 0.300 | 0.500 | 0.012 | 0.020 |
| c | 0.100 | 0.200 | 0.004 | 0.008 |
| D | 2.820 | 3.020 | 0.111 | 0.119 |
| E | 1.500 | 1.700 | 0.059 | 0.067 |
| E1 | 2.650 | 2.950 | 0.104 | 0.116 |
| e | 0.950(BSC) | | 0.037(BSC) | |
| e1 | 1.800 | 2.000 | 0.071 | 0.079 |
| L | 0.300 | 0.600 | 0.012 | 0.024 |
| θ | 0° | 8° | 0° | 8° |

SOT89-5

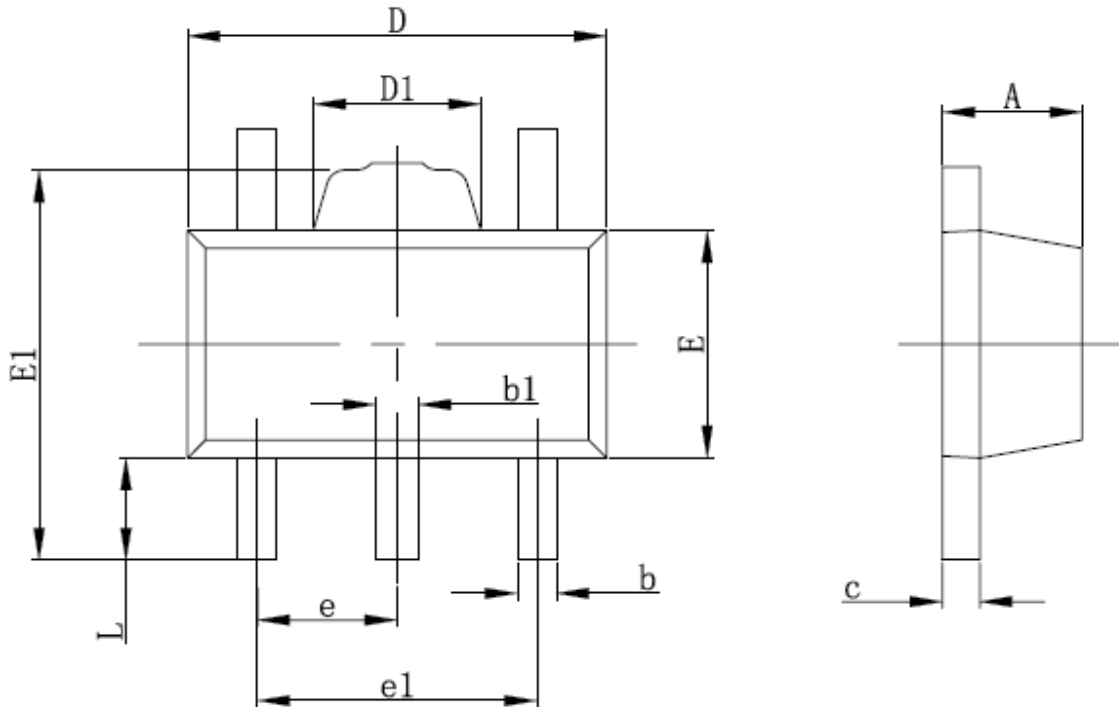

| Symbol | Dimensions In Millimeters | | Dimensions In Inches | |
|--------|---------------------------|-------|----------------------|-------|
| | Min | Max | Min | Max |
| A | 1.400 | 1.600 | 0.055 | 0.063 |
| b | 0.320 | 0.520 | 0.013 | 0.020 |
| b1 | 0.360 | 0.560 | 0.014 | 0.022 |
| c | 0.350 | 0.440 | 0.014 | 0.017 |
| D | 4.400 | 4.600 | 0.173 | 0.181 |
| D1 | 1.400 | 1.800 | 0.055 | 0.071 |
| E | 2.300 | 2.600 | 0.091 | 0.102 |
| E1 | 3.940 | 4.250 | 0.155 | 0.167 |
| e | 1.500TYP | | 0.060TYP | |
| e1 | 2.900 | 3.100 | 0.114 | 0.122 |
| L | 0.900 | 1.100 | 0.035 | 0.043 |