

PROGRAMMABLE 27-BIT DISPLAY SERIAL INTERFACE TRANSMITTER

FEATURES

- FlatLink™3G Serial-Interface Technology
- Compatible With FlatLink3G Receivers Such as SN65LVDS306
- Input Supports 24-bit RGB Video Mode Interface
- 24-Bit RGB Data, 3 Control Bits, 1 Parity Bit, and 2 Reserved Bits Transmitted Over One Differential Line
- SubLVDS Differential Voltage Levels
- Effective Data Throughput up to 405 Mbps
- Three Operating Modes to Conserve Power
 - Active-Mode QVGA 17.4 mW (Typical)
 - Shutdown Mode $\approx 0.5 \mu\text{A}$ (Typical)
 - Standby Mode $\approx 0.5 \mu\text{A}$ (Typical)
- Bus Swap for Increased PCB Layout Flexibility
- 1.8-V Supply Voltage
- ESD Rating > 2 kV (HBM)
- Typical Application: Host-Controller to Display-Module Interface
- Pixel Clock Range of 4 MHz–15 MHz
- Failsafe on all CMOS Inputs
- Packaging: 80-Terminal 5-mm × 5-mm $\mu\text{BGA}^{\circledR}$

DESCRIPTION

The SN65LVDS305 serializer device converts 27 parallel data inputs to one sub-low-voltage differential signaling (SubLVDS) serial output. It loads a shift register with 24 pixel bits and 3 control bits from the parallel CMOS input interface. In addition to the 27 data bits, the device adds a parity bit and two reserved bits into a 30-bit data word. Each word is latched into the device by the pixel clock (PCLK). The parity bit (odd parity) allows a receiver to detect single bit errors. The serial shift register is uploaded at 30 times the pixel-clock data rate. A copy of the pixel clock is output on a separate differential output.

FPC cabling typically interconnects the SN65LVDS305 with the display. Compared to parallel signaling, the SN65LVDS305 outputs reduce the EMI of the interconnect by over 20 dB.

The SN65LVDS305 supports three power modes (shutdown, standby and active) to conserve power. When transmitting, the PLL locks to the incoming pixel clock, PCLK, and generates an internal high-speed clock at the line rate of the data lines. The parallel data are latched on the rising or falling edge of PCLK, as selected by the external control signal CPOL. The serialized data is presented on the serial output, D, together with a recreated PCLK generated from the internal high-speed clock that is output on CLK. If PCLK stops, the device enters a standby mode to conserve power.

The parallel (CMOS) input bus offers a bus-swap feature. The SWAP terminal configures the input order of the pixel data to be either R[7:0], G[7:0], B[7:0], VS, HS, DE or B[0:7], G[0:7], R[0:7], VS, HS, DE. This gives a PCB designer the flexibility to better match the bus to the host controller pinout or to put the transmitter device on the top side or the bottom side of the PCB.

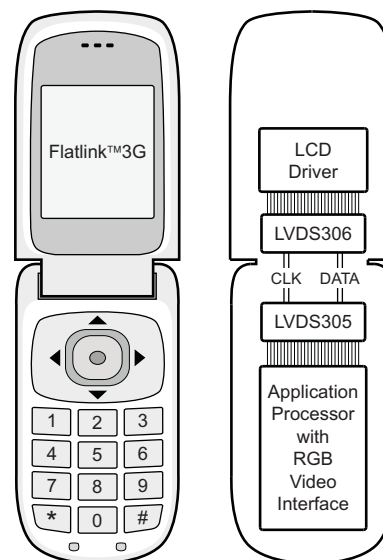

Please be aware that an important notice concerning availability, standard warranty, and use in critical applications of Texas Instruments semiconductor products and disclaimers thereto appears at the end of this data sheet.

FlatLink is a trademark of Texas Instruments.
 μBGA is a registered trademark of Tessera, Inc..



These devices have limited built-in ESD protection. The leads should be shorted together or the device placed in conductive foam during storage or handling to prevent electrostatic damage to the MOS gates.

DESCRIPTION (CONTINUED)

The TXEN input can be used to put the SN65LVDS305 in a shutdown mode. The SN65LVDS305 enters an active standby mode if the input clock, PCLK, stops. This minimizes power consumption without the need for controlling an external terminal. The SN65LVDS305 is characterized for operation over ambient air temperatures of -40°C to 85°C . All CMOS inputs offer failsafe to protect the input from damage during power up and to avoid current flow into the device inputs during power up. An input voltage of up to 2.165 V can be applied to all CMOS inputs while V_{DD} is between 0 V and 1.65 V.

Functional Block Diagram

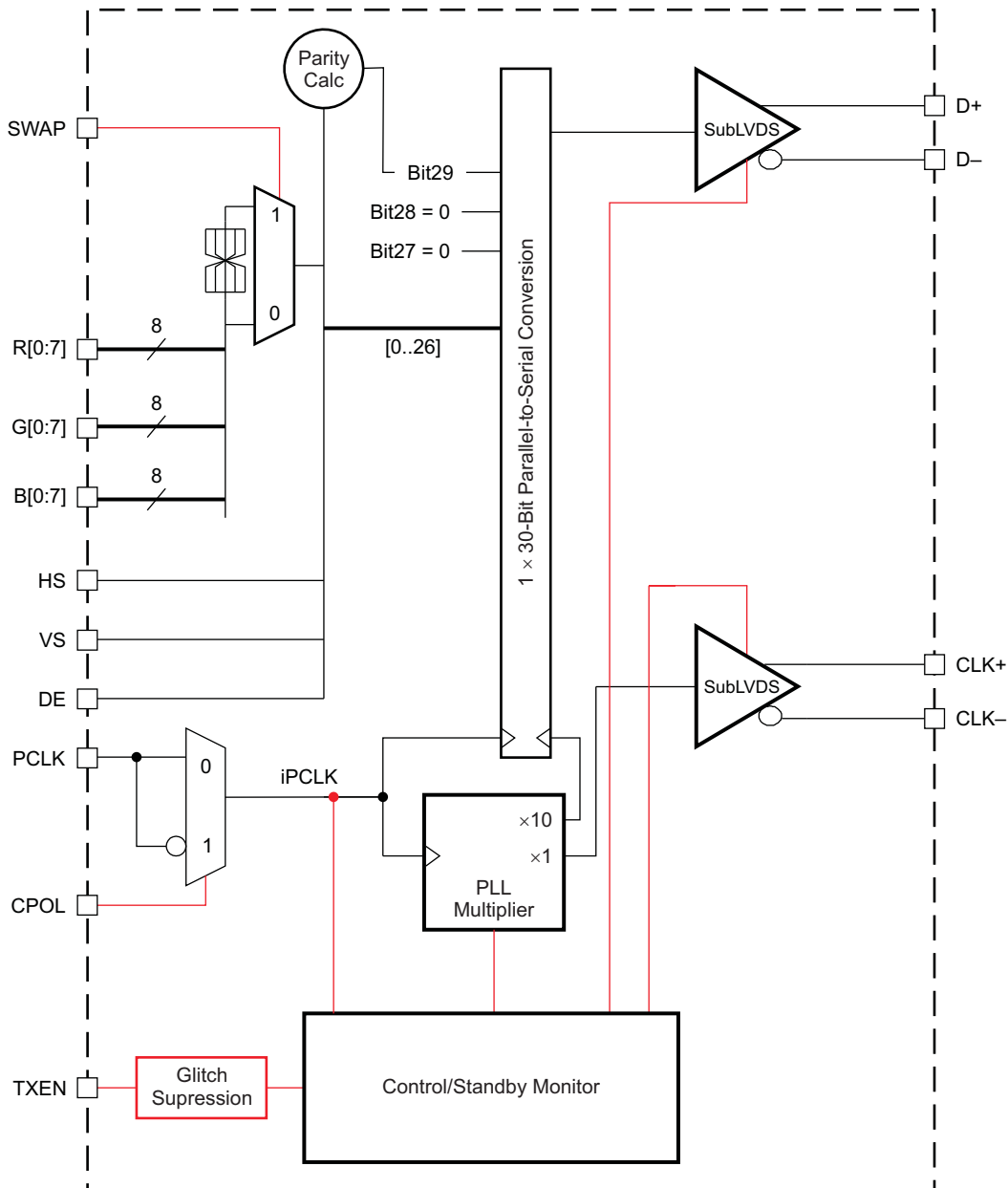

PINOUT – TOP VIEW

| | 1 | 2 | 3 | 4 | 5 | 6 | 7 | 8 | 9 |
|---|-------|-------|-------|---------------------|--------------------|---------------------|---------------------|---------------------|---------------------|
| A | GND | G2/G5 | G4/G3 | G6/G1 | R0/B7 | R2/B5 | R4/B3 | R6/B1 | GND |
| B | G0/G7 | G1/G6 | G3/G4 | G5/G2 | G7/G0 | R1/B6 | R3/B4 | R5/B2 | R7/B0 |
| C | B6/R1 | B7/R0 | | VDD | GND | VDD | VDD | GND | GND |
| D | B4/R3 | B5/R2 | VDD | GND | GND | GND | GND | GND | NC |
| E | B3/R4 | GND | VDD | GND | GND | GND | GND | GND _{PLLD} | NC |
| F | B1/R6 | B2/R5 | VDD | GND | GND | GND | GND | V _{DDPLLD} | NC |
| G | PCLK | B0/R7 | VDD | GND | GND | GND | GND | GND _{LVDS} | NC |
| H | HS | VS | GND | GND _{LVDS} | V _{DDLVD} | GND _{PLLA} | V _{DDPLLA} | V _{DDLVD} | CPOL |
| J | GND | DE | TXEN | D- | D+ | CLK- | CLK+ | SWAP | GND _{LVDS} |

RGB Input pin assignment based on SWAP pin setting:

SWAP=0/SWAP=1

PINOUT – TOP VIEW (continued)

SWAP TERMINAL FUNCTIONALITY

The SWAP terminal allows the pcb designer to reverse the RGB bus, thus minimize potential signal crossovers due to signal routing. Figure 1 and Figure 2 show the RGB signal terminal assignment based on the SWAP terminal setting.

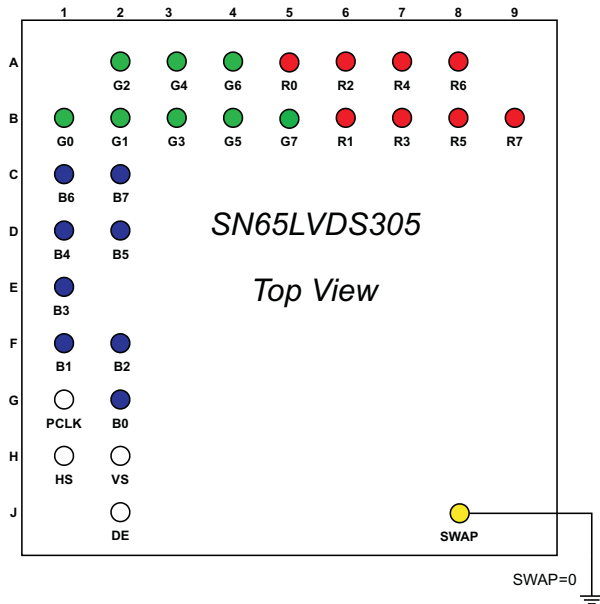

Figure 1. SWAP TERMINAL = 0

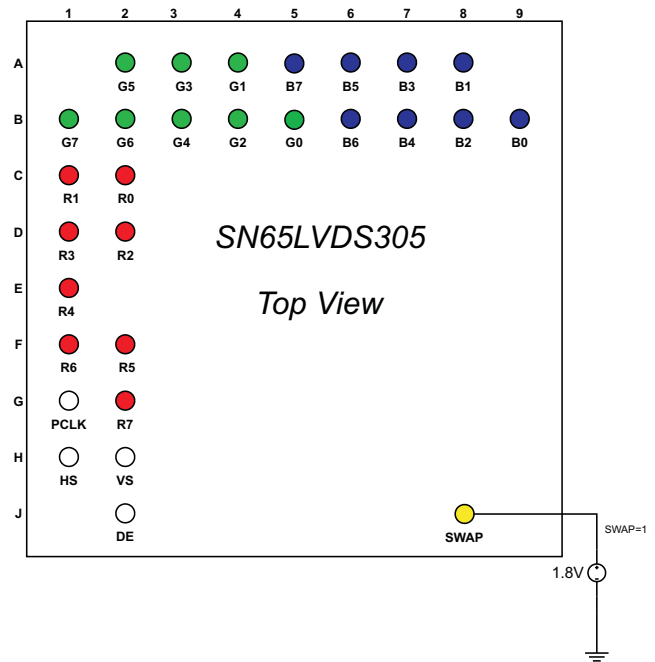

Figure 2. SWAP Terminal = 1

PINOUT – TOP VIEW (continued)

Table 1. NUMERIC TERMINAL LIST

| TERMINAL | SWAP | SIGNAL | TERMINAL | SWAP | SIGNAL | TERMINAL | SWAP | SIGNAL |
|----------|------|--------|----------|-------------|--------------------|----------|------|----------------------|
| A1 | — | GND | C1 | 0 | B6 | F1 | 0 | B1 |
| A2 | 0 | G2 | | 1 | R1 | | 1 | R6 |
| | 1 | G5 | C2 | 0 | B7 | F2 | 0 | B2 |
| A3 | 0 | G4 | | 1 | R0 | | 1 | R5 |
| | 1 | G3 | C3 | UNPOPULATED | | F3 | — | VDD |
| A4 | 0 | G6 | C4 | — | VDD | F4 | — | GND |
| | 1 | G1 | C5 | — | GND | F5 | — | GND |
| A5 | 0 | R0 | C6 | — | VDD | F6 | — | GND |
| | 1 | B7 | C7 | — | VDD | F7 | — | GND |
| A6 | 0 | R2 | C8 | — | GND | F8 | — | V _{DDPLL} |
| | 1 | B5 | C9 | — | GND | F9 | — | NC |
| A7 | 0 | R4 | D1 | 0 | B4 | G1 | — | PCLK |
| | 1 | B3 | | 1 | R3 | | G2 | 0 |
| A8 | 0 | R6 | D2 | 0 | B5 | 1 | | R7 |
| | 1 | B1 | | 1 | R2 | G3 | — | V _{DD} |
| A9 | — | GND | D3 | — | VDD | G4 | — | GND |
| B1 | 0 | G0 | D4 | — | GND | G5 | — | GND |
| | 1 | G7 | D5 | — | GND | G6 | — | GND |
| B2 | 0 | G1 | D6 | — | GND | G7 | — | GND |
| | 1 | G6 | D7 | — | GND | G8 | — | GND _{LVDS} |
| B3 | 0 | G3 | D8 | — | GND | G9 | — | NC |
| | 1 | G4 | D9 | — | NC | H1 | — | HS |
| B4 | 0 | G5 | E1 | 0 | B3 | H2 | — | VS |
| | 1 | G2 | | 1 | R4 | H3 | — | GND |
| B5 | 0 | G7 | E2 | — | GND | H4 | — | GND _{LVDS} |
| | 1 | G0 | E3 | — | VDD | H5 | — | V _{DDL} VDS |
| B6 | 0 | R1 | E4 | — | GND | H6 | — | GND _{PLLA} |
| | 1 | B6 | E5 | — | GND | H7 | — | V _{DD} PLLA |
| B7 | 0 | R3 | E6 | — | GND | H8 | — | V _{DDL} VDS |
| | 1 | B4 | E7 | — | GND | H9 | — | CPOL |
| B8 | 0 | R5 | E8 | — | GND _{PLL} | J1 | — | GND |
| | 1 | B2 | E9 | — | NC | J2 | — | DE |
| B9 | 0 | R7 | | | | J3 | — | TXEN |
| | 1 | B0 | | | | J4 | — | D– |
| | | | | | | J5 | — | D+ |
| | | | | | | J6 | — | CLK– |
| | | | | | | J7 | — | CLK+ |
| | | | | | | J8 | — | SWAP |
| | | | | | | J9 | — | GND _{LVDS} |

TERMINAL FUNCTIONS

| NAME | I/O | DESCRIPTION |
|----------------------|-----------------------------|---|
| D+, D– | SubLVDS Out | SubLVDS data link (active during normal operation) |
| CLK+, CLK– | | SubLVDS output clock; clock polarity is fixed. |
| R0–R7 | CMOS IN | Red pixel data (8); terminal assignment depends on SWAP terminal setting. |
| G0–G7 | | Green pixel data (8); terminal assignment depends on SWAP terminal setting. |
| B0–B7 | | Blue pixel data (8); terminal assignment depends on SWAP terminal setting. |
| HS | | Horizontal sync |
| VS | | Vertical sync |
| DE | | Data enable |
| PCLK | | Input pixel clock; rising or falling clock polarity is selected by control input CPOL. |
| TXEN | | Disables the CMOS drivers and turns off the PLL, putting device in shutdown mode 1 – Transmitter enabled 0 – Transmitter disabled (shutdown) |
| | | Note: The TXEN input incorporates glitch-suppression logic to avoid device malfunction on short input spikes. It is necessary to pull TXEN high for longer than 10 μs to enable the transmitter. It is necessary to pull the TXEN input low for longer than 10 μs to disable the transmitter. At power up, the transmitter is enabled immediately if TXEN = 1 and disabled if TXEN = 0. |
| CPOL | | CMOS In |
| SWAP | CMOS In | Bus swap. Swaps the bus terminals to allow device placement on top or bottom of pcb. See pinout drawing for terminal assignments. 0 – data input from B0...R7 1 – data input from R7...B0 |
| V _{DD} | Power supply ⁽¹⁾ | Supply voltage |
| GND | | Supply ground |
| V _{DDL} VDS | | SubLVDS I/O supply voltage |
| GND _{LVDS} | | SubLVDS ground |
| V _{DD} PLLA | | PLL analog supply voltage |
| GND _{PLLA} | | PLL analog GND |
| V _{DD} PLLD | | PLL digital supply voltage |
| GND _{PLLD} | | PLL digital GND |

(1) For a multilayer pcb, it is recommended to keep one common GND layer underneath the device and connect all ground terminals directly to this plane.

FUNCTIONAL DESCRIPTION

The SN65LVDS305 transmits payload data over a single SubLVDS data pair, D. The PLL locks to PCLK and internally multiplies the clock by a factor of 30. The internal high-speed clock is used to serialize (shift out) the data payload on D. Two reserved bits and the parity bit are added to the data frame. Figure 3 illustrates the timing and the mapping of the data payload into the 30-bit frame. The internal high-speed clock is divided by a factor of 30 to recreate the pixel clock, and presented on the SubLVDS CLK output. While in this mode, the PLL can lock to a clock that is in the range of 4 MHz through 15 MHz. This is intended for smaller video display formats (e.g. QVGA to HVGA) .



Figure 3. Data and Clock Output

Power-Down Modes

The SN65LVDS305 transmitter has two power-down modes to facilitate efficient power management.

Shutdown Mode

The SN65LVDS305 enters shutdown mode when the TXEN terminal is asserted low. This turns off all transmitter circuitry, including the CMOS input, PLL, serializer, and SubLVDS transmitter output stage. All outputs are high-impedance. Current consumption in shutdown mode is nearly zero.

Standby Mode

The SN65LVDS305 enters the standby mode if TXEN is high and the PCLK input signal frequency is less than 500 kHz. All circuitry except the PCLK input monitor is shut down, and all outputs enter the high-impedance state. The current consumption in standby mode is very low. When the PCLK input signal is completely stopped, the I_{DD} current consumption is less than 10 μ A. The PCLK input must not be left floating.

NOTE:

A floating (left open) CMOS input allows leakage currents to flow from V_{DD} to GND. To prevent large leakage current, a CMOS gate must be kept at a valid logic level, either V_{IH} or V_{IL} . This can be achieved by applying an external voltage of V_{IH} or V_{IL} to all SN65LVDS305 inputs.

Active Modes

When TXEN is high and the PCLK input clock signal is faster than 3 MHz, the SN65LVDS305 enters the active mode. Current consumption in the active mode depends on operating frequency and the number of data transitions in the data payload.

Acquire Mode (PLL Approaches Lock)

The PLL is enabled and attempts to lock to the input clock. All outputs remain in the high-impedance state. When the PLL monitor detects stable PLL operation, the device switches from the acquire mode to the transmit mode. For proper device operation, the pixel clock frequency must fall within the valid f_{PCLK} range specified under recommended operating conditions. If the pixel clock frequency is larger than 3MHz but smaller than $f_{PCLK}(\min)$, the SN65LVDS305 PLL is enabled. Under such conditions, it is possible for the PLL to lock temporarily to the pixel clock, causing the PLL monitor to release the device into transmit mode. If this happens, the PLL may or may not be properly locked to the pixel clock input, potentially causing data errors, frequency oscillation, and PLL deadlock (loss of VCO oscillation).

Transmit Mode

After the PLL achieves lock, the device enters the normal transmit mode. The CLK terminal outputs a copy of PCLK.

FUNCTIONAL DESCRIPTION (continued)

Parity Bit Generation

The SN65LVDS305 transmitter calculates the parity of the transmit data word and sets the parity bit accordingly. The parity bit covers the 27-bit data payload consisting of 24 bits of pixel data plus VS, HS, and DE. The two reserved bits are not included in the parity generation. Odd-parity bit signaling is used. The transmitter sets the parity bit if the sum of the 27 data bits result in an even number of ones. The parity bit is cleared otherwise. This allows the receiver to verify parity and detect single bit errors.

Status Detect and Operating Modes Flow diagram

The SN65LVDS305 switches between the power saving and active modes in the following way:

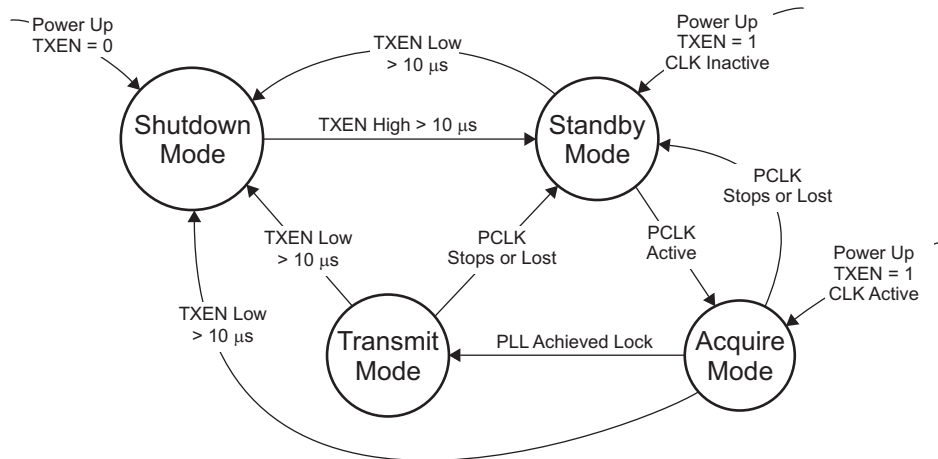

Figure 4. Status Detect and Operating Modes Flow Diagram

Table 2. Status Detect and Operating Modes Descriptions

| Mode | Characteristics | Conditions |
|---------------|--|--|
| Shutdown mode | Least amount of power consumption ⁽¹⁾ (most circuitry turned off); all outputs are high-impedance. | TXEN is low. ⁽¹⁾⁽²⁾ |
| Standby mode | Low power consumption (only clock activity circuit active; PLL is disabled to conserve power); all outputs are high-impedance. | TXEN is high; PCLK input signal is missing or inactive. ⁽²⁾ |
| Acquire mode | PLL tries to achieve lock; all outputs are high-impedance. | TXEN is high; PCLK input monitor detected input activity. |
| Transmit mode | Data transfer (normal operation); Transmitter serializes data and transmits data on serial output. | TXEN is high and PLL is locked to incoming clock. |

- (1) In shutdown mode, all SN65LVDS305 internal switching circuits (e.g., PLL, serializer, etc.) are turned off to minimize power consumption. The input stage of any input terminal remains active.
- (2) Leaving inputs unconnected can cause random noise to toggle the input stage and potentially harm the device. All inputs must be tied to a valid logic level, V_{IL} or V_{IH}, during shutdown or standby mode.

Operating Mode Transitions

| MODE TRANSITION | USE CASE | TRANSITION SPECIFICS |
|-----------------------------|--|---|
| Shutdown → standby | Drive TXEN high to enable transmitter | 1. TXEN high > 10 μs 2. Transmitter enters standby mode. a. All outputs are high-impedance. b. Transmitter turns on clock input monitor. |
| Standby → acquire | Transmitter activity detected | 1. PCLK input monitor detects clock input activity. 2. Outputs remain high-impedance. 3. PLL circuit is enabled. |
| Acquire → transmit | Link is ready to transfer data. | 1. PLL is active and approaches lock. 2. PLL achieved lock within 2 ms. 3. Parallel data input latches into shift register . 4. CLK output turns on. 5. Selected data outputs turn on and send out first serial data bit. |
| Transmit → standby | Request transmitter to enter standby mode by stopping PCLK | 1. PCLK Input monitor detects missing PCLK. 2. Transmitter indicates standby, putting all outputs into high-impedance. 3. PLL shuts down. 4. PCLK activity input monitor remains active. |
| Transmit/standby → shutdown | Turn off transmitter | 1. TXEN pulled low for longer than 10 μs 2. Transmitter indicates standby, putting output CLK+ and CLK– into high-impedance state. 3. Transmitter puts all other outputs into high-impedance state. 4. Most IC circuitry is shut down for least power consumption. |

ORDERING INFORMATION

| PART NUMBER | PACKAGE | SHIPPING METHOD |
|-----------------|---------|-----------------|
| SN65LVDS305ZQER | ZQE | Reel |

ABSOLUTE MAXIMUM RATINGS⁽¹⁾

over operating free-air temperature range (unless otherwise noted)

| | VALUE | UNIT |
|--|---|--------------------------|
| Supply voltage range, $V_{DD}^{(2)}$, V_{DDPLL_A} , V_{DDPLL_D} , V_{DDLVD_S} | –0.3 to 2.175 | V |
| Voltage range at any input or output terminal | When $V_{DDx} > 0$ V | –0.5 to 2.175 |
| | When $V_{DDx} \leq 0$ V | –0.5 to $V_{DD} + 2.175$ |
| Electrostatic discharge | Human-body model ⁽³⁾ (all terminals) | ±3 |
| | Charged-device model ⁽⁴⁾ (all terminals) | ±500 |
| | Machine model ⁽⁵⁾ (all terminals) | ±200 |
| Continuous power dissipation | See Dissipation Ratings table | |

(1) Stresses beyond those listed under *absolute maximum ratings* may cause permanent damage to the device. These are stress ratings only and functional operation of the device at these or any other conditions beyond those indicated under *recommended operating conditions* is not implied. Exposure to absolute maximum-rated conditions for extended periods may affect device reliability.

(2) All voltage values are with respect to the GND terminals.

(3) In accordance with JEDEC Standard 22, Test Method A114-A.

(4) In accordance with JEDEC Standard 22, Test Method C101.

(5) In accordance with JEDEC Standard 22, Test Method A115-A

DISSIPATION RATINGS

| PACKAGE | CIRCUIT BOARD MODEL | $T_A < 25^\circ\text{C}$ | DERATING FACTOR ⁽¹⁾ ABOVE $T_A = 25^\circ\text{C}$ | $T_A = 85^\circ\text{C}$ POWER RATING |
|---------|----------------------|--------------------------|---|---------------------------------------|
| ZQE | Low-K ⁽²⁾ | 592 mW | 7.407 mW/°C | 148 mW |

(1) This is the inverse of the junction-to-ambient thermal resistance when board-mounted and with no air flow.

(2) In accordance with the low-K thermal metric definitions of EIA/JESD51-2.

THERMAL CHARACTERISTICS

| PARAMETER | TEST CONDITIONS | VALUE | UNIT |
|---|---|---------------|------|
| P_D Device power dissipation, maximum | $V_{DDx} = 1.95\text{ V}$, $T_A = -40^\circ\text{C}$ | PCLK at 4 MHz | 22.3 |
| | | PCLK = 15 MHz | 36.7 |

RECOMMENDED OPERATING CONDITIONS⁽¹⁾

| | | MIN | NOM | MAX | UNIT |
|---|--|---|-----|-----------------|--------|
| V_{DD} V_{DDPLLA} V_{DDPLLD} V_{DDLVDs} | Supply voltages | 1.65 | 1.8 | 1.95 | V |
| $V_{DDn(PP)}$ | Supply voltage noise magnitude 50 MHz (all supplies) | | | 100 | mV |
| f_{PCLK} | Pixel clock frequency | | 4 | 15 | MHz |
| | | 1-channel transmit mode, see Figure 3 Frequency threshold Standby mode to active mode ⁽²⁾ , see Figure 14 | 0.5 | 3 | |
| $t_H \times f_{PCLK}$ | PCLK input duty cycle | 0.33 | | 0.67 | |
| T_A | Operating free-air temperature | -40 | | 85 | °C |
| $t_{jit(per)PCLK}$ | PCLK RMS period jitter ⁽³⁾ | | | 5 | ps-rms |
| $t_{jit(TJ)PCLK}$ | PCLK total jitter | | | $0.05/f_{PCLK}$ | s |
| $t_{jit(CC)PCLK}$ | PCLK peak cycle-to-cycle jitter ⁽⁴⁾ | | | $0.02/f_{PCLK}$ | s |
| PCLK, R[0:7], G[0:7], B[0:7], VS, HS, DE, PCLK, CPOL, TXEN, SWAP | | | | | |
| V_{IH} | High-level input voltage | $0.7 V_{DD}$ | | V_{DD} | V |
| V_{IL} | Low-level input voltage | | | $0.3 V_{DD}$ | V |
| t_{DS} | Data set up time prior to PCLK transition | $f(PCLK) = 10\text{ MHz}$; see Figure 6 | 2 | | ns |
| t_{DH} | Data hold time after PCLK transition | | 2 | | ns |

(1) Unused single-ended inputs must be held high or low to prevent them from floating.

(2) PCLK input frequencies lower than 500 kHz force the SN65LVDS305 into standby mode. Input frequencies between 500 kHz and 3 MHz may or may not activate the SN65LVDS305. Input frequencies beyond 3 MHz activate the SN65LVDS305.

(3) Period jitter is the deviation in cycle time of a signal with respect to the ideal period over a random sample of 100,000 cycles.

(4) Cycle-to-cycle jitter is the variation in cycle time of a signal between adjacent cycles over a random sample of 1,000 adjacent cycle pairs.

DEVICE ELECTRICAL CHARACTERISTICS

over recommended operating conditions (unless otherwise noted)

| PARAMETER | TEST CONDITIONS | MIN | TYP ⁽¹⁾ | MAX | UNIT | |
|-----------------|--|---|--------------------|------|------|----|
| I _{DD} | V _{DD} = V _{DDPLLA} = V _{DDPLLD} = V _{DDLVDSD} , R _{L(PCLK)} = R _{L(D)} = 100 Ω, V _{IH} = V _{DD} , V _{IL} = 0 V, TXEN at V _{DD} , alternating 1010 serial bit pattern | f _{PCLK} = 4 MHz | | 9 | 11.4 | mA |
| | | f _{PCLK} = 6 MHz | | 10.6 | 12.6 | |
| | | f _{PCLK} = 15 MHz | | 16 | 18.8 | |
| | V _{DD} = V _{DDPLLA} = V _{DDPLLD} = V _{DDLVDSD} , R _{L(PCLK)} = R _{L(D)} = 100 Ω, V _{IH} = V _{DD} , V _{IL} = 0 V, TXEN at V _{DD} , typical power test pattern (see Table 4) | f _{PCLK} = 4 MHz | | 8 | | mA |
| | | f _{PCLK} = 6 MHz | | 8.9 | | |
| | | f _{PCLK} = 15 MHz | | 14 | | |
| | Standby mode | V _{DD} = V _{DDPLLA} = V _{DDPLLD} = V _{DDLVDSD} , R _{L(PCLK)} = R _{L(D)} = 100 Ω, V _{IH} = V _{DD} , V _{IL} = 0 V, all inputs held static high or static low | | 0.61 | 10 | μA |
| | Shutdown mode | | | 0.55 | 10 | μA |

(1) All typical values are at 25°C and with 1.8 V supply unless otherwise noted.

OUTPUT ELECTRICAL CHARACTERISTICS

over operating free-air temperature range (unless otherwise noted)

| PARAMETER | TEST CONDITIONS | MIN | TYP ⁽¹⁾ | MAX | UNIT | |
|--|---|-----|--------------------|-----|------|----|
| subLVDS output (D+, D-, CLK+, and CLK-) | | | | | | |
| V _{OC(SS)M} | Steady-state common-mode output voltage | | 0.8 | 0.9 | 1.0 | V |
| V _{OCM(SS)} | Change in steady-state common-mode output voltage | | -10 | | 10 | mV |
| V _{OCM(PP)} | Peak-to-peak common mode output voltage | | | | 75 | mV |
| V _{OD} | Differential output voltage magnitude V _{Dx+} - V _{Dx-} , V _{CLK+} - V _{CLK-} | | 100 | 150 | 200 | mV |
| Δ V _{OD} | Change in differential output voltage between logic states | | -10 | | 10 | mV |
| Z _{OD(CLK)} | Differential small-signal output impedance | | | 210 | | Ω |
| I _{OSD} | Differential short-circuit output current | | | | 10 | mA |
| I _{OS} | Short circuit output current ⁽²⁾ | | | 5 | | |
| I _{OZ} | High-impedance state output current | | -3 | | 3 | μA |

(1) All typical values are at 25°C and with 1.8-V supply unless otherwise noted.

(2) All SN65LVDS305 outputs tolerate shorts to GND or V_{DD} without permanent device damage.

INPUT ELECTRICAL CHARACTERISTICS

over operating free-air temperature range (unless otherwise noted)

| PARAMETER | TEST CONDITIONS | MIN | TYP ⁽¹⁾ | MAX | UNIT | |
|---|--------------------------|-----|--------------------|-----|------|----|
| PCLK, R[0:7], G[0:7], B[0:7], VS, HS, DE, PCLK, CPOL, TXEN, SWAP | | | | | | |
| I _{IH} | High-level input current | | -200 | | 200 | nA |
| I _{IL} | Low-level input current | | -200 | | 200 | |
| C _{IN} | Input capacitance | | | 1.5 | | pF |

(1) All typical values are at 25°C and with 1.8-V supply unless otherwise noted.

SWITCHING CHARACTERISTICS

over recommended operating conditions (unless otherwise noted)

| PARAMETER | TEST CONDITIONS | MIN | TYP ⁽¹⁾ | MAX | UNIT |
|-----------------------|--|--|--------------------|------------------|---------|
| t_r | 20%-to-80% differential output signal rise time | See Figure 7 and Figure 8 | | 500 | ps |
| t_f | 20%-to-80% differential output signal fall time | See Figure 7 and Figure 8 | | 500 | |
| f_{BW} | PLL bandwidth (3-dB cutoff frequency) | Tested from PCLK input to CLK output, See Figure 5 ⁽²⁾ | | $0.076 f_{PCLK}$ | MHz |
| $t_{pd(L)}$ | Propagation delay time, input to serial output (data latency Figure 9) | TXEN at V_{DD} , $V_{IH}=V_{DD}$, $V_{IL}=GND$, $R_L=100 \Omega$ | | $1/f_{PCLK}$ | s |
| $t_H \times f_{CLK0}$ | Output CLK duty cycle | 0.45 | 0.5 | 0.55 | |
| t_{GS} | TXEN glitch suppression pulse width ⁽³⁾ | $V_{IH}=V_{DD}$, $V_{IL}=GND$, TXEN toggles between V_{IL} and V_{IH} , see Figure 12 and Figure 13 | | 10 | μs |
| t_{pwrap} | Enable time from power down (\uparrow TXEN) | Time from TXEN pulled high to CLK and D outputs enabled and transmit valid data; see Figure 13 | | 2 | ms |
| t_{pwrdn} | Disable time from active mode (\downarrow TXEN) | TXEN is pulled low during transmit mode; time measurement until output is disabled and PLL is shut down; see Figure 13 | | 11 | μs |
| t_{wakeup} | Enable time from standby (\uparrow PCLK) | TXEN at V_{DD} ; device in standby; time measurement from PCLK starts switching to CLK and D outputs enabled and transmit valid data; see Figure 13 | | 2 | ms |
| t_{sleep} | Disable time from active mode (PCLK stopping) | TXEN at V_{DD} ; device is transmitting; time measurement from PCLK input signal stops until CLK + D outputs are disabled and PLL is disabled; see Figure 13 | | 100 | μs |

- (1) All typical values are at 25°C and with 1.8-V supply unless otherwise noted.
- (2) The maximum limit is based on statistical analysis of the device performance over process, voltage, and temperature ranges. This parameter is functionality tested only on automatic test equipment (ATE).
- (3) The TXEN input incorporates glitch-suppression circuitry to disregard short input pulses. t_{GS} is the duration of either a high-to-low or low-to-high transition that is suppressed.

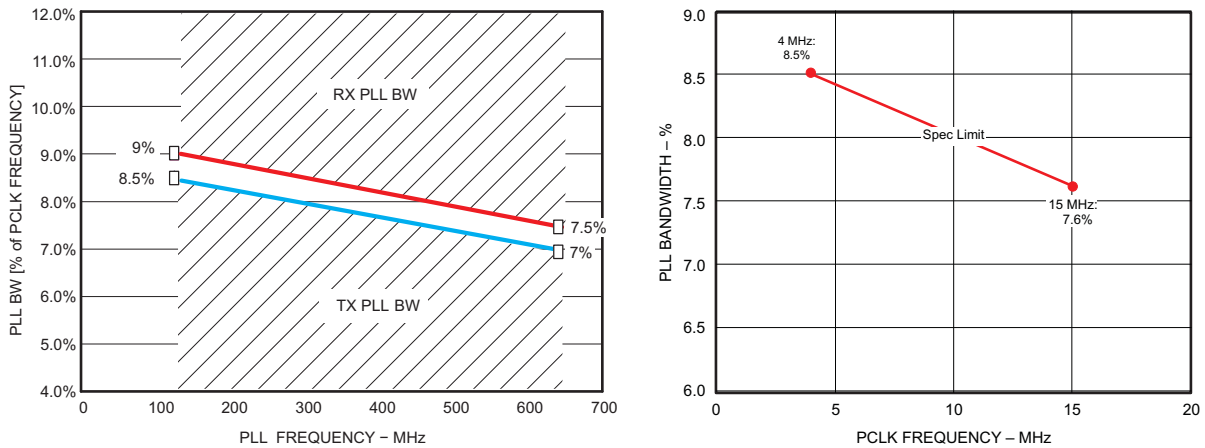

Figure 5. SN65LVDS305 PLL Bandwidth (Also Showing the SN65LVDS306 PLL Bandwidth)

TIMING CHARACTERISTICS

| PARAMETER | TEST CONDITIONS | MIN | TYP | MAX | UNIT |
|---|---|--|-----|--|------|
| t _{PPOSX} Output pulse position, serial data to ↑CLK; see (1)(2)and Figure 11 | x = 0..29, f _{PCLK} = 15 MHz; TXEN at V _{DD} , V _{IH} = V _{DD} , V _{IL} = GND, R _L = 100 Ω, test pattern as in Table 6 ⁽³⁾ | $\frac{x}{30 \cdot f_{PCLK}} - 330 \text{ ps}$ | | $\frac{x}{30 \cdot f_{PCLK}} + 330 \text{ ps}$ | ps |
| | x = 0..29, f _{PCLK} = 4 MHz to 15 MHz ⁽⁴⁾ | $\frac{x - 0.1845}{30 \cdot f_{PCLK}}$ | | $\frac{x + 0.1845}{30 \cdot f_{PCLK}}$ | |

- (1) This number also includes the high-frequency random and deterministic PLL clock jitter that is not traceable by the SN65LVDS306 receiver PLL; t_{PPOSX} represents the total timing uncertainty of the transmitter necessary to calculate the jitter budget when combined with the SN65LVDS306 receiver.
- (2) The pulse position min/max variation is given with a bit error rate target of 10⁻¹²; the measurement estimates the random jitter contribution to the total jitter by multiplying the random RMS jitter by the factor 14; measurements of the total jitter are taken with > 10⁻¹² samples.
- (3) The minimum and maximum limits are based on statistical analysis of the device performance over process, voltage, and temperature ranges. This parameter is functionality tested only on automatic test equipment (ATE).
- (4) These minimum and maximum limits are simulated only.

PARAMETER MEASUREMENT INFORMATION

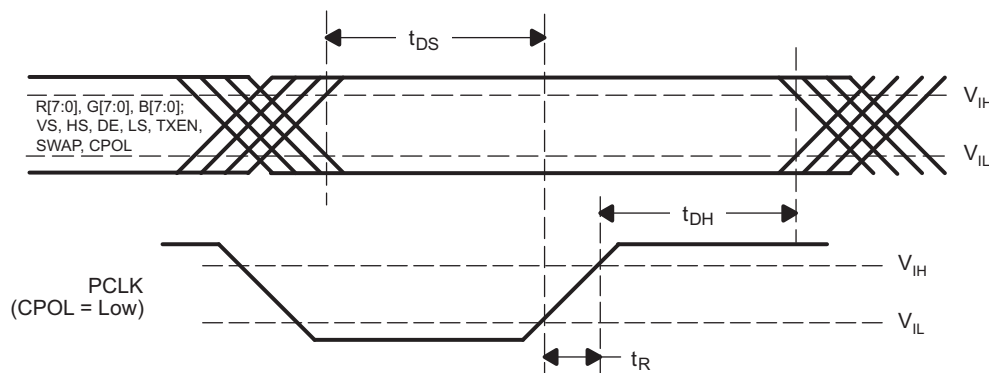

Figure 6. Setup/Hold Time

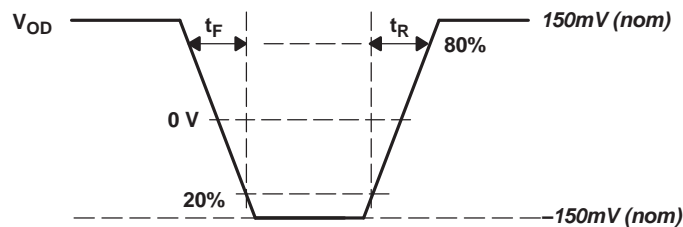
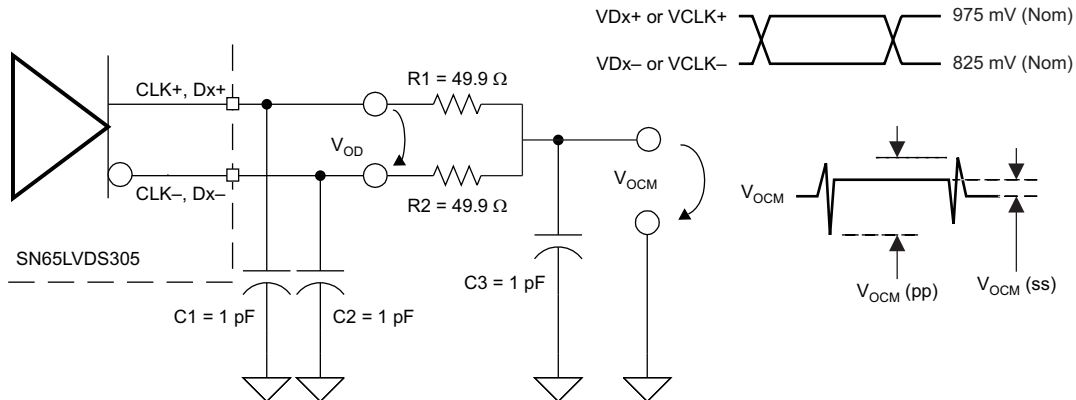

Figure 7. Rise and Fall Time Definitions

PARAMETER MEASUREMENT INFORMATION (continued)



NOTES:

- A. 15-MHz output test pattern on all differential outputs (CLK and D); this is achieved by:
 1. $f_{PCLK} = 15 \text{ MHz}$
 2. Inputs R[7:0] connected to V_{DD} ; all other data inputs set to GND.
- B. C1, C2, and C3 include instrumentation and fixture capacitance, tolerance $\pm 20\%$; C, R1, and R2 tolerance $\pm 1\%$
- C. The measurement of $V_{OCM(pp)}$ and $V_{OCM(ss)}$ are taken with test equipment bandwidth $>1 \text{ GHz}$.

Figure 8. Driver Output Voltage Test Circuit and Definitions

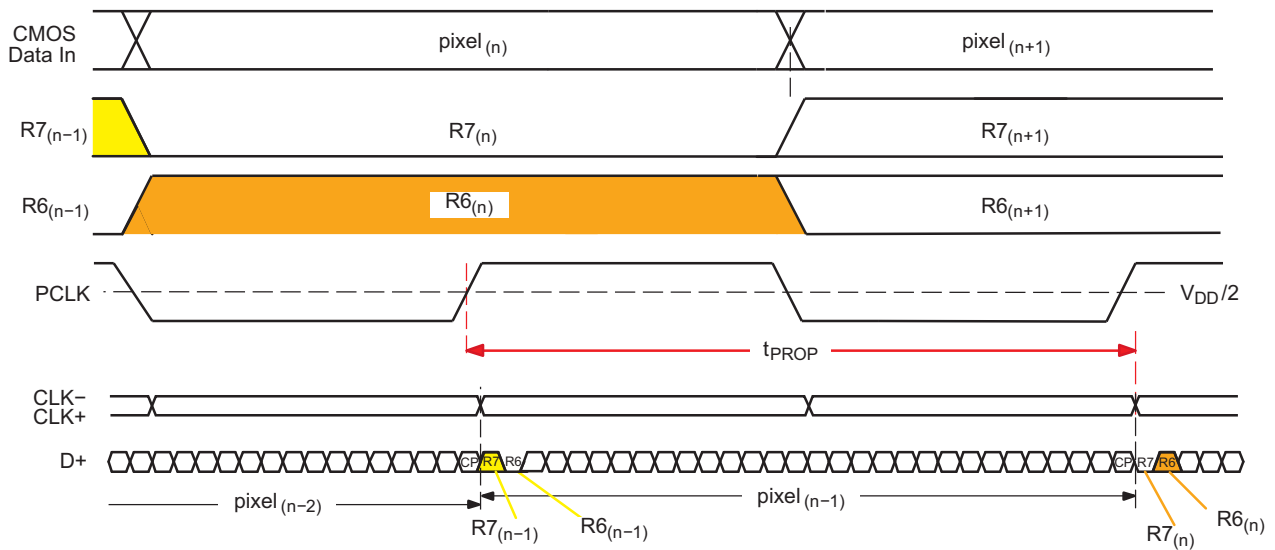
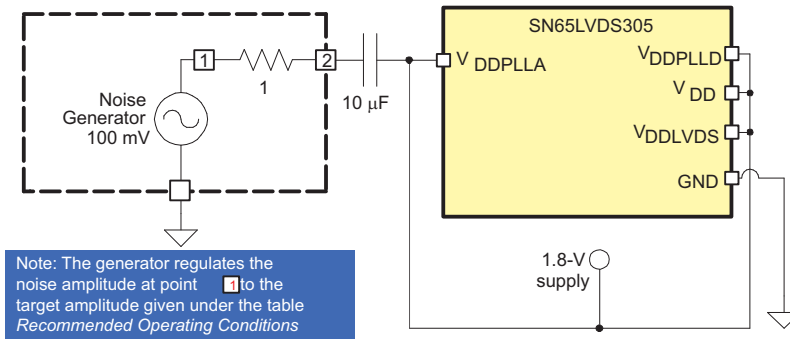

Figure 9. $t_{pd(L)}$ Propagation Delay Input to Output (CPOL = 1)



Note: The generator regulates the noise amplitude at point 1 to the target amplitude given under the table Recommended Operating Conditions

Figure 10. Power Supply Noise Test Setup

PARAMETER MEASUREMENT INFORMATION (continued)

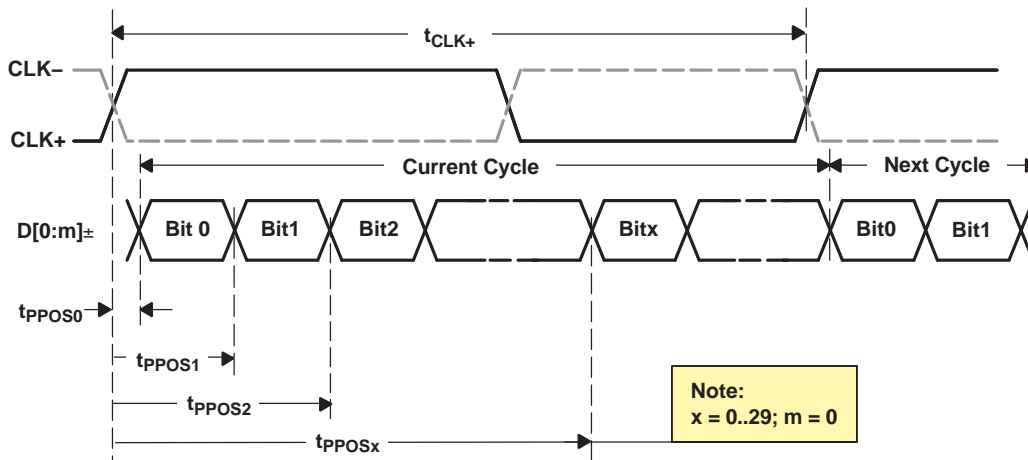

Figure 11. $t_{SK(0)}$ SubLVDS Output Pulse Position Measurement

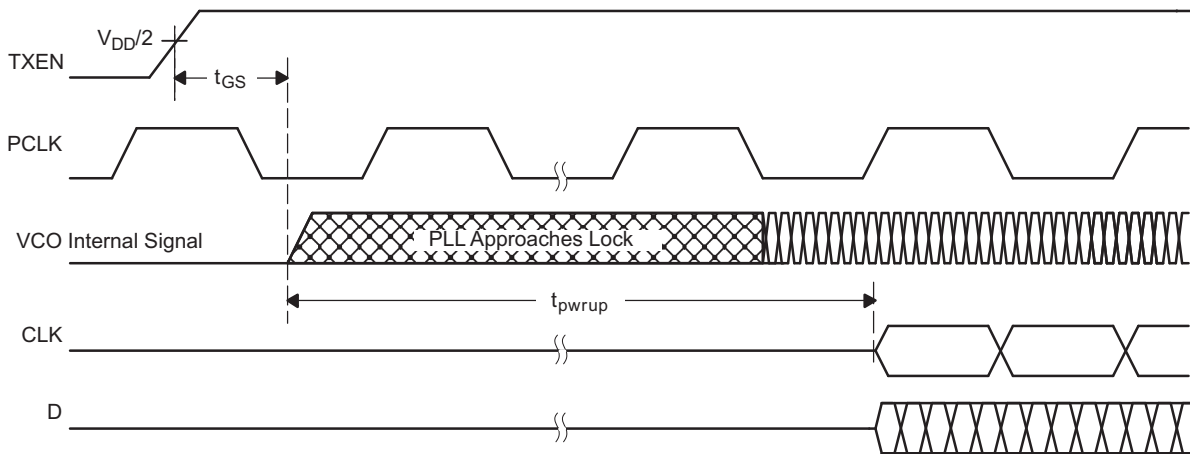

Figure 12. Transmitter Behavior While Approaching Sync

PARAMETER MEASUREMENT INFORMATION (continued)

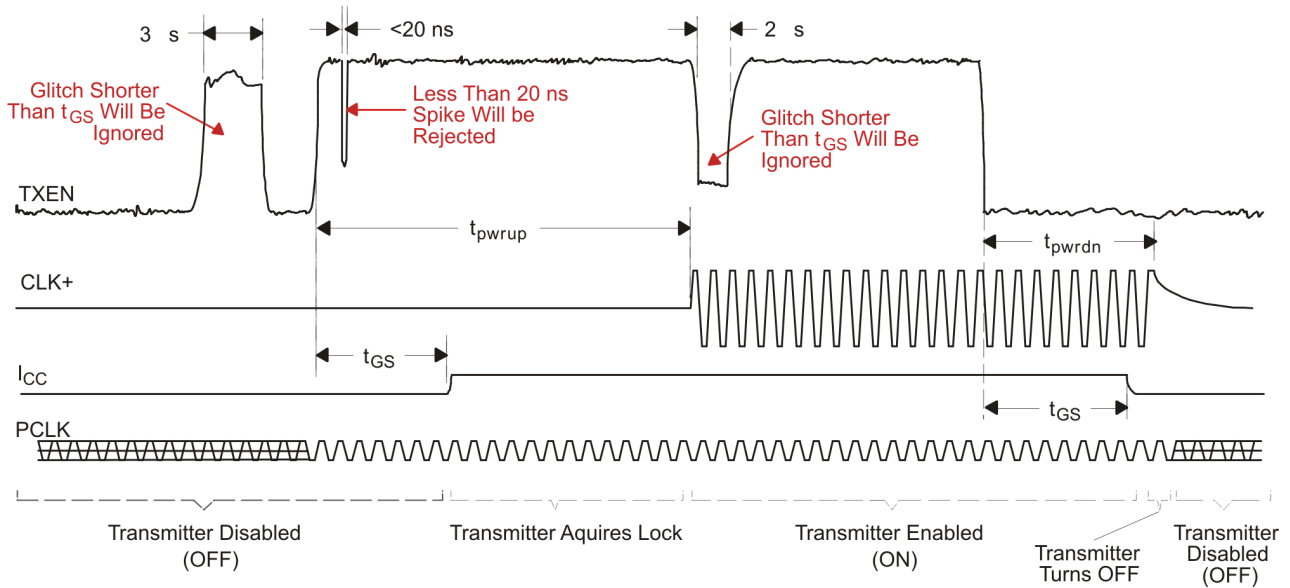

Figure 13. Transmitter Enable Glitch Suppression Time

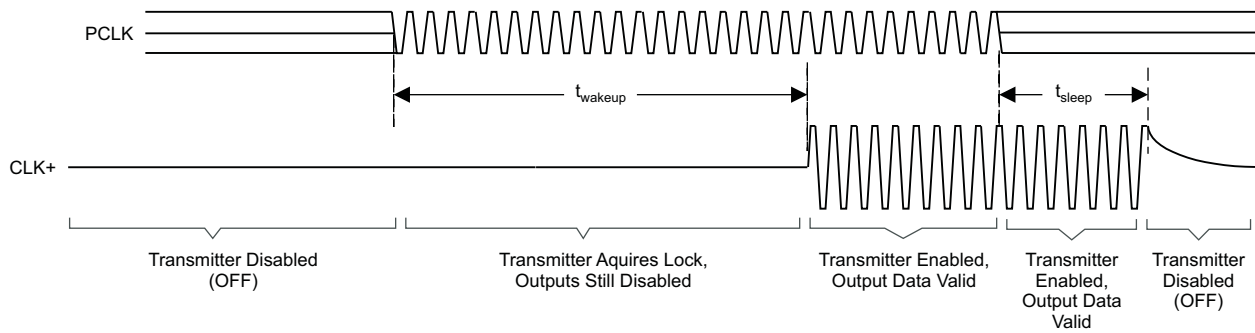

Figure 14. Standby Detection

Power Consumption Tests

Table 3 shows an example test pattern word.

Table 3. Example Test Pattern Word

| Word | R[7:4], R[3:0], G[7:4], G[3:0], B[7:4], B[3:0], 0, VS, HS, DE |
|------|---|
| 1 | 0x7C3E1E7 |

| 7 | | | | C | | | | 3 | | | | E | | | | 1 | | | | E | | | | 7 | | | |
|----|----|----|----|----|----|----|----|----|----|----|----|----|----|----|----|----|----|----|----|----|----|----|----|---|----|----|----|
| R7 | R6 | R5 | R4 | R3 | R2 | R1 | R0 | G7 | G6 | G5 | G4 | G3 | G2 | G1 | G0 | B7 | B6 | B5 | B4 | B3 | B2 | B1 | B0 | 0 | VS | HS | DE |
| 0 | 1 | 1 | 1 | 1 | 1 | 0 | 0 | 0 | 0 | 1 | 1 | 1 | 1 | 1 | 0 | 0 | 0 | 0 | 1 | 1 | 1 | 1 | 0 | 0 | 1 | 1 | 1 |

Typical IC Power-Consumption Test Pattern

The typical power consumption test pattern consists of sixteen 30-bit transmit words. The pattern repeats itself throughout the entire measurement. It is assumed that every possible transmit code on RGB inputs has the same probability to occur during typical device operation.

Table 4. Typical IC Power-Consumption Test Pattern

| Word | Test Pattern: R[7:4], R[3:0], G[7:4], G[3:0], B[7:4], B[3:0], 0, VS, HS, DE |
|------|--|
| 1 | 0x0000007 |
| 2 | 0xFFFF007 |
| 3 | 0x01FFF47 |
| 4 | 0xF0E07F7 |
| 5 | 0x7C3E1E7 |
| 6 | 0xE707C37 |
| 7 | 0xE1CE6C7 |
| 8 | 0xF1B9237 |
| 9 | 0x91BB347 |
| 10 | 0xD4CCC67 |
| 11 | 0xAD53377 |
| 12 | 0xACB2207 |
| 13 | 0xAAB2697 |
| 14 | 0x5556957 |
| 15 | 0xAAAAAB3 |
| 16 | 0xAAAAA5 |

Maximum Power-Consumption Test Pattern

The maximum (or worst-case) power consumption of the SN65LVDS305 is tested using the two different test patterns shown in table. The test patterns consist of sixteen 30-bit transmit words. The pattern repeats itself throughout the entire measurement. It is assumed that every possible transmit code on RGB inputs has the same probability to occur during typical device operation.

Table 5. Worst-Case Power-Consumption Test Pattern

| Word | Test Pattern: R[7:4], R[3:0], G[7:4], G[3:0], B[7:4], B[3:0], 0, VS, HS, DE |
|------|--|
| 1 | 0xAAAAA5 |
| 2 | 0x5555555 |

Output Skew Pulse Position and Jitter Performance

The following test patterns are used to measure the output skew pulse position and the jitter performance of the SN65LVDS305. The jitter test patterns stress the interconnect for worst-case ISI. Each pattern is self-repeating for the duration of the test.

Table 6. Transmit Jitter Test Pattern

| Word | Test Pattern: R[7:4], R[3:0], G[7:4], G[3:0], B[7:4], B[3:0], 0, VS, HS, DE |
|------|--|
| 1 | 0x0000001 |
| 2 | 0x0000031 |
| 3 | 0x00000F1 |
| 4 | 0x00003F1 |
| 5 | 0x0000FF1 |
| 6 | 0x0003FF1 |
| 7 | 0x000FFF1 |
| 8 | 0x0F0F0F1 |
| 9 | 0x0C30C31 |
| 10 | 0x0842111 |
| 11 | 0x1C71C71 |
| 12 | 0x18C6311 |
| 13 | 0x1111111 |
| 14 | 0x3333331 |
| 15 | 0x2452413 |
| 16 | 0x22A2A25 |
| 17 | 0x5555553 |
| 18 | 0xDB6DB65 |
| 19 | 0xCCCCC1 |
| 20 | 0xEEEEE1 |
| 21 | 0xE739CE1 |
| 22 | 0xE38E381 |
| 23 | 0xF7BDEE1 |
| 24 | 0xF3CF3C1 |
| 25 | 0xF0F0F01 |
| 26 | 0xFFFF001 |
| 27 | 0xFFFC001 |
| 28 | 0xFFFF001 |
| 29 | 0xFFFC01 |
| 30 | 0xFFFF01 |
| 31 | 0xFFFC1 |
| 32 | 0xFFFF1 |

TYPICAL CHARACTERISTICS

POWERDOWN, STANDBY SUPPLY CURRENT vs TEMPERATURE

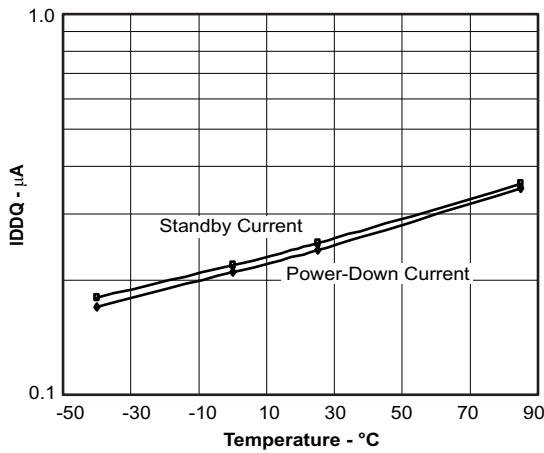

Figure 15.

SUPPLY CURRENT I_{DD} vs TEMPERATURE

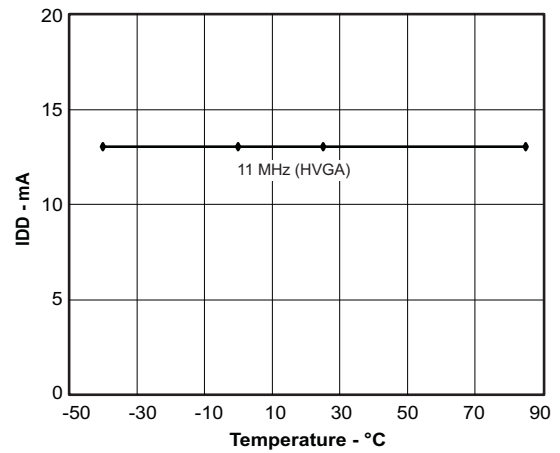

Figure 16.

SUPPLY CURRENT vs PCLK FREQUENCY

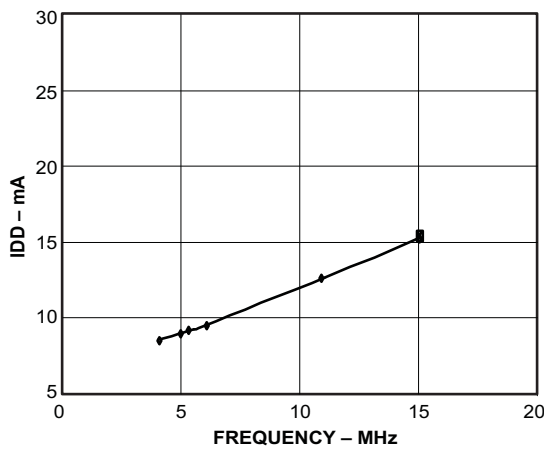

Figure 17.

DIFFERENTIAL OUTPUT SWING vs PCLK FREQUENCY

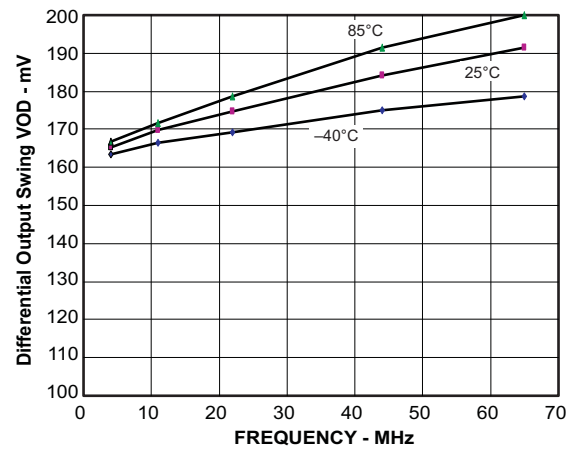

Figure 18.

PLL BANDWIDTH

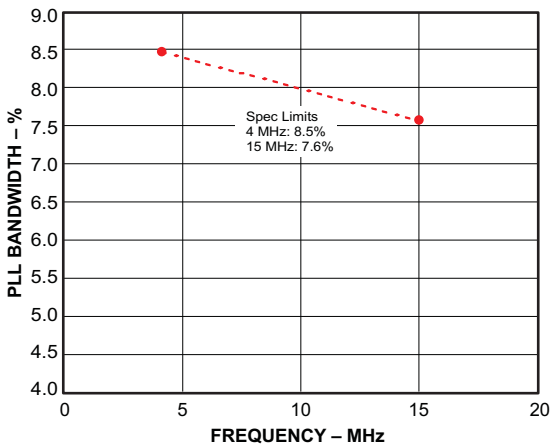

Figure 19.

CYCLE-TO-CYCLE OUTPUT JITTER vs PCLK FREQUENCY

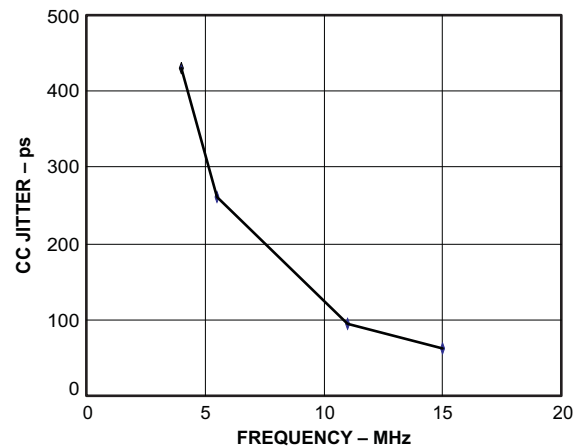

Figure 20.

TYPICAL CHARACTERISTICS (continued)

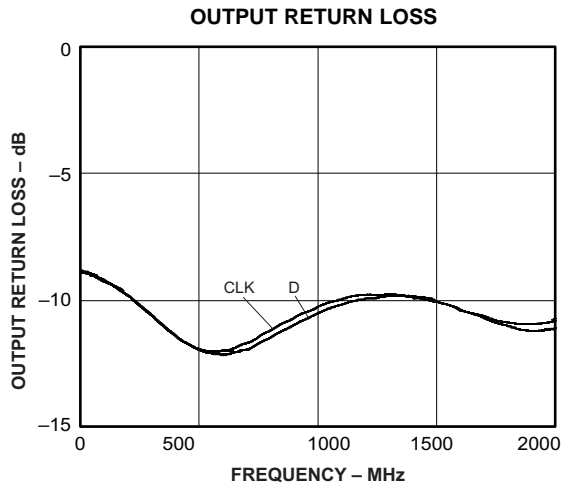

Figure 21.

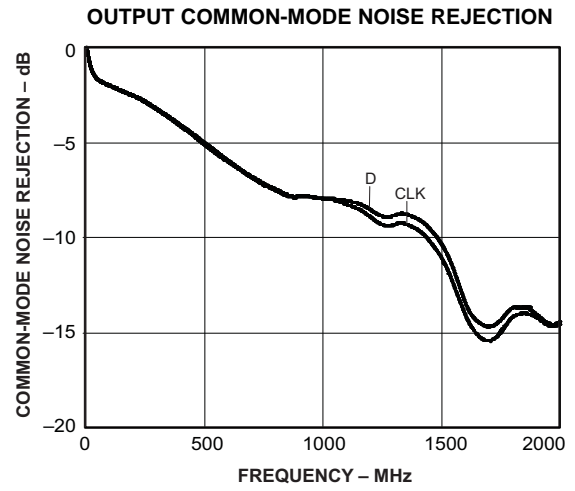

Figure 22.

APPLICATION INFORMATION

Preventing Increased Leakage Currents in Control Inputs

A floating (left open) CMOS input allows leakage currents to flow from V_{DD} to GND. Do not leave any CMOS Input unconnected or floating. Every input must be connected to a valid logic level, V_{IH} or V_{OL} , while power is supplied to V_{DD} . This also minimizes the power consumption of standby and power-down modes.

Power Supply Design Recommendation

For a multilayer pcb, it is recommended to keep one common GND layer underneath the device and connect all ground terminals directly to this plane.

Decoupling Recommendation

The SN65LVDS305 was designed to operate reliably in a constricted environment with other digital switching ICs. In cell phone designs, the SN65LVDS305 often shares a power supply with the application processor. The SN65LVDS305 can operate with power-supply noise as specified in *Recommend Operating Conditions*. To minimize the power-supply noise floor, provide good decoupling near the SN65LVDS305 power terminals. The use of four ceramic capacitors ($2 \times 0.01 \mu\text{F}$ and $2 \times 0.1 \mu\text{F}$) provides good performance. At the very least, it is recommended to install one $0.1 \mu\text{F}$ and one $0.01 \mu\text{F}$ capacitor near the SN65LVDS305. To avoid large current loops and trace inductance, the trace length between decoupling capacitor and IC power input terminals must be minimized. Placing the capacitor underneath the SN65LVDS305 on the bottom of the pcb is often a good choice.

Typical Application Frequencies

The SN65LVDS305 supports pixel clock frequencies from 4 MHz to 15 MHz. [Table 7](#) provides a few typical display resolution examples and shows the number of data lanes necessary to connect the SN65LVDS305 with the display. The blanking overhead is assumed to be 20%. Often, blanking overhead is smaller, resulting in a lower data rate. Furthermore, the examples in the table assumes a display frame refresh rate of 60 Hz. The actual refresh rate may differ depending on the application-processor clock implementation.

Table 7. Typical Application Data Rates and Serial Lane Usage

| Display Screen Resolution | Visible Pixel Count | Blanking Overhead | Display Refresh Rate | Pixel Clock Frequency [MHz] | Serial Data Rate |
|---------------------------|---------------------|-------------------|----------------------|-----------------------------|------------------|
| 176 × 220 (QCIF+) | 38,720 | 20% | 90 Hz | 4.2 MHz | 125 Mbps |
| 240 × 320 (QVGA) | 76,800 | | 60 Hz | 5.5 MHz | 166 Mbps |
| 640 × 200 | 128,000 | | | 9.2 MHz | 276 Mbps |
| 352 × 416 (CIF+) | 146,432 | | | 10.5 MHz | 316 Mbps |
| 352 × 440 | 154,880 | | | 11.2 MHz | 335 Mbps |
| 320 × 480 (HVGA) | 153,600 | | | 11.1 MHz | 332 Mbps |
| 800 × 250 | 200,000 | | | 14.4 MHz | 432 Mbps |
| 640 × 320 | 204,800 | | | 14.7 MHz | 442 Mbps |

Calculation Example: HVGA Display

This example calculation shows a typical half-VGA display with these parameters:

| | |
|---------------------------|-------------|
| Display resolution: | 320 × 480 |
| Frame refresh rate: | 58.4 Hz |
| Vertical visible pixel: | 480 lines |
| Vertical front porch: | 20 lines |
| Vertical sync: | 5 lines |
| Vertical back porch: | 3 lines |
| Horizontal visible pixel: | 320 columns |
| Horizontal front porch: | 10 columns |
| Horizontal sync: | 5 columns |
| Horizontal back porch: | 3 columns |

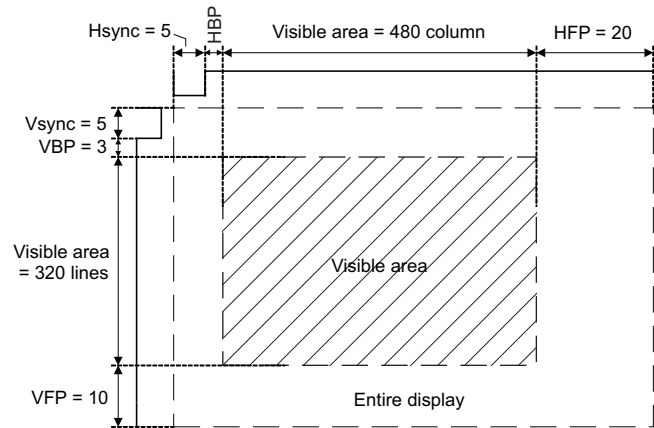

Figure 23. HVGA Display Parameters

Calculation of the total number of pixels and blanking overhead:

| | |
|---------------------------|---|
| Visible area pixel count: | $480 \times 320 = 153,600$ pixels |
| Total frame pixel count: | $(480 + 20 + 5 + 3) \times (320 + 10 + 5 + 3) = 173,304$ pixels |
| Blanking overhead: | $(173,304 - 153,600) \div 153,600 = 12.8\%$ |

The application requires following serial-link parameters:

| | |
|----------------------|--|
| Pixel clk frequency: | $173,304 \times 58.4 \text{ Hz} = 10.1 \text{ MHz}$ |
| Serial data rate: | $10.4 \text{ MHz} \times 30 \text{ bits} = 304 \text{ Mbps}$ |

PACKAGING INFORMATION

| Orderable Device | Status ⁽¹⁾ | Package Type | Package Drawing | Pins | Package Qty | Eco Plan ⁽²⁾ | Lead/Ball Finish | MSL Peak Temp ⁽³⁾ |
|------------------|-----------------------|----------------------------------|-----------------|------|-------------|----------------------------|------------------|------------------------------|
| SN65LVDS305ZQE | ACTIVE | BGA MI CROSTA R JUNI OR | ZQE | 80 | 360 | TBD | Call TI | Call TI |
| SN65LVDS305ZQER | ACTIVE | BGA MI CROSTA R JUNI OR | ZQE | 80 | 2500 | Green (RoHS & no Sb/Br) | SNAGCU | Level-3-260C-168 HR |

⁽¹⁾ The marketing status values are defined as follows:

ACTIVE: Product device recommended for new designs.

LIFEBUY: TI has announced that the device will be discontinued, and a lifetime-buy period is in effect.

NRND: Not recommended for new designs. Device is in production to support existing customers, but TI does not recommend using this part in a new design.

PREVIEW: Device has been announced but is not in production. Samples may or may not be available.

OBSOLETE: TI has discontinued the production of the device.

⁽²⁾ Eco Plan - The planned eco-friendly classification: Pb-Free (RoHS), Pb-Free (RoHS Exempt), or Green (RoHS & no Sb/Br) - please check <http://www.ti.com/productcontent> for the latest availability information and additional product content details.

TBD: The Pb-Free/Green conversion plan has not been defined.

Pb-Free (RoHS): TI's terms "Lead-Free" or "Pb-Free" mean semiconductor products that are compatible with the current RoHS requirements for all 6 substances, including the requirement that lead not exceed 0.1% by weight in homogeneous materials. Where designed to be soldered at high temperatures, TI Pb-Free products are suitable for use in specified lead-free processes.

Pb-Free (RoHS Exempt): This component has a RoHS exemption for either 1) lead-based flip-chip solder bumps used between the die and package, or 2) lead-based die adhesive used between the die and leadframe. The component is otherwise considered Pb-Free (RoHS compatible) as defined above.

Green (RoHS & no Sb/Br): TI defines "Green" to mean Pb-Free (RoHS compatible), and free of Bromine (Br) and Antimony (Sb) based flame retardants (Br or Sb do not exceed 0.1% by weight in homogeneous material)

⁽³⁾ MSL, Peak Temp. -- The Moisture Sensitivity Level rating according to the JEDEC industry standard classifications, and peak solder temperature.

Important Information and Disclaimer:The information provided on this page represents TI's knowledge and belief as of the date that it is provided. TI bases its knowledge and belief on information provided by third parties, and makes no representation or warranty as to the accuracy of such information. Efforts are underway to better integrate information from third parties. TI has taken and continues to take reasonable steps to provide representative and accurate information but may not have conducted destructive testing or chemical analysis on incoming materials and chemicals. TI and TI suppliers consider certain information to be proprietary, and thus CAS numbers and other limited information may not be available for release.

In no event shall TI's liability arising out of such information exceed the total purchase price of the TI part(s) at issue in this document sold by TI to Customer on an annual basis.

ZQE (S-PBGA-N80)

PLASTIC BALL GRID ARRAY

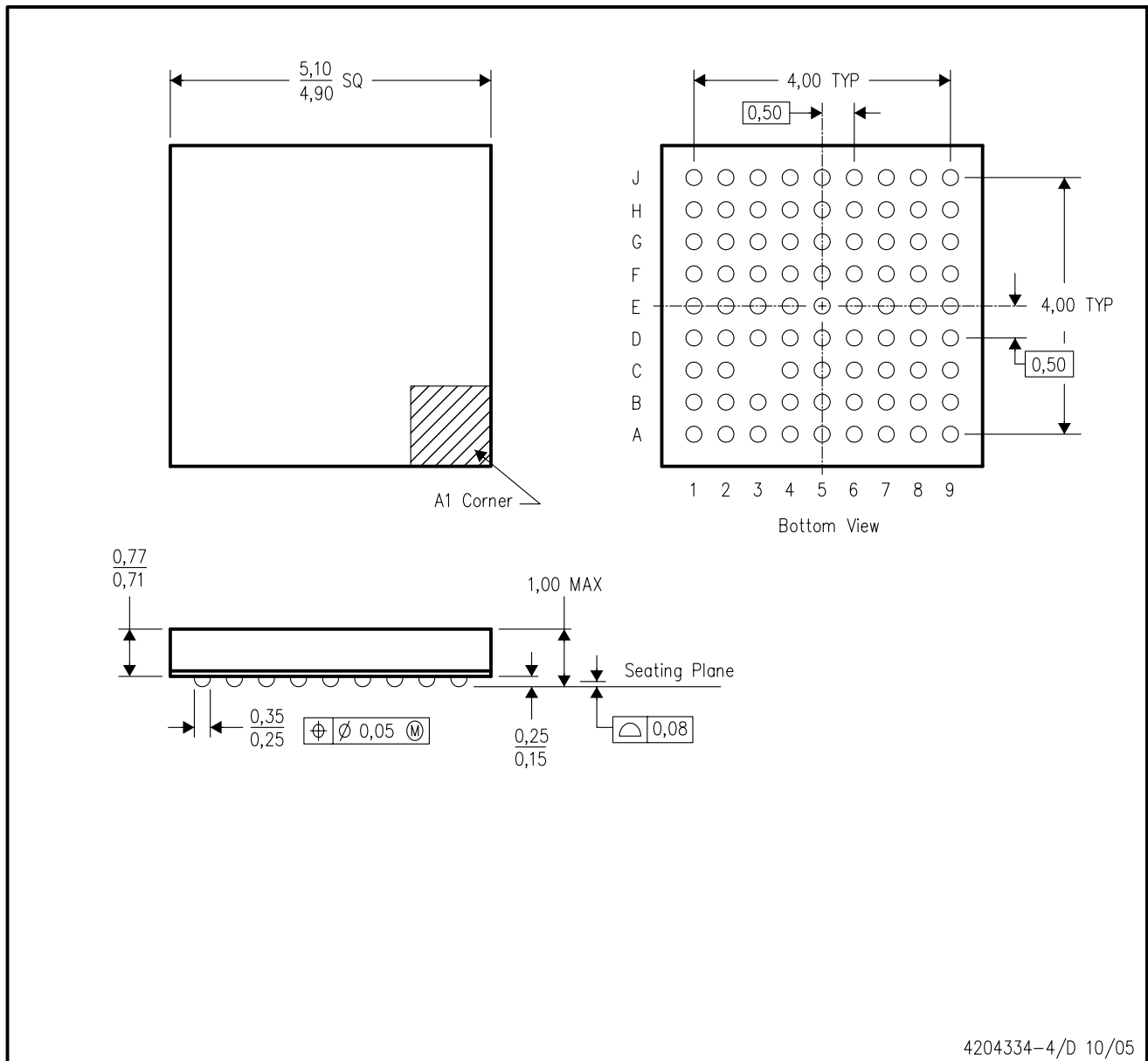

- NOTES:
- A. All linear dimensions are in millimeters.
 - B. This drawing is subject to change without notice.
 - C. Falls within JEDEC MO-225
 - D. This is a lead-free solder ball design.

IMPORTANT NOTICE

Texas Instruments Incorporated and its subsidiaries (TI) reserve the right to make corrections, modifications, enhancements, improvements, and other changes to its products and services at any time and to discontinue any product or service without notice. Customers should obtain the latest relevant information before placing orders and should verify that such information is current and complete. All products are sold subject to TI's terms and conditions of sale supplied at the time of order acknowledgment.

TI warrants performance of its hardware products to the specifications applicable at the time of sale in accordance with TI's standard warranty. Testing and other quality control techniques are used to the extent TI deems necessary to support this warranty. Except where mandated by government requirements, testing of all parameters of each product is not necessarily performed.

TI assumes no liability for applications assistance or customer product design. Customers are responsible for their products and applications using TI components. To minimize the risks associated with customer products and applications, customers should provide adequate design and operating safeguards.

TI does not warrant or represent that any license, either express or implied, is granted under any TI patent right, copyright, mask work right, or other TI intellectual property right relating to any combination, machine, or process in which TI products or services are used. Information published by TI regarding third-party products or services does not constitute a license from TI to use such products or services or a warranty or endorsement thereof. Use of such information may require a license from a third party under the patents or other intellectual property of the third party, or a license from TI under the patents or other intellectual property of TI.

Reproduction of information in TI data books or data sheets is permissible only if reproduction is without alteration and is accompanied by all associated warranties, conditions, limitations, and notices. Reproduction of this information with alteration is an unfair and deceptive business practice. TI is not responsible or liable for such altered documentation.

Resale of TI products or services with statements different from or beyond the parameters stated by TI for that product or service voids all express and any implied warranties for the associated TI product or service and is an unfair and deceptive business practice. TI is not responsible or liable for any such statements.

Following are URLs where you can obtain information on other Texas Instruments products and application solutions:

| Products | | Applications | |
|--------------------|--|---------------------|--|
| Amplifiers | amplifier.ti.com | Audio | www.ti.com/audio |
| Data Converters | dataconverter.ti.com | Automotive | www.ti.com/automotive |
| DSP | dsp.ti.com | Broadband | www.ti.com/broadband |
| Interface | interface.ti.com | Digital Control | www.ti.com/digitalcontrol |
| Logic | logic.ti.com | Military | www.ti.com/military |
| Power Mgmt | power.ti.com | Optical Networking | www.ti.com/opticalnetwork |
| Microcontrollers | microcontroller.ti.com | Security | www.ti.com/security |
| Low Power Wireless | www.ti.com/lpw | Telephony | www.ti.com/telephony |
| | | Video & Imaging | www.ti.com/video |
| | | Wireless | www.ti.com/wireless |

Mailing Address: Texas Instruments
Post Office Box 655303 Dallas, Texas 75265