

**FEATURES**

- Member of the Texas Instruments Widebus+™ Family
- Output Ports Have Equivalent 22-Ω Series Resistors, So No External Resistors Are Required
- Supports Mixed-Mode Signal Operation (5-V Input and Output Voltages With 3.3-V V<sub>CC</sub>)
- Supports Unregulated Battery Operation Down to 2.7 V
- Typical V<sub>OLP</sub> (Output Ground Bounce) <0.8 V at V<sub>CC</sub> = 3.3 V, T<sub>A</sub> = 25°C
- I<sub>off</sub> and Power-Up 3-State Support Hot Insertion

- Bus Hold on Data Inputs Eliminates the Need for External Pullup/Pulldown Resistors
- Distributed V<sub>CC</sub> and GND Pins Minimize High-Speed Switching Noise
- Flow-Through Architecture Optimizes PCB Layout
- Latch-Up Performance Exceeds 500 mA Per JESD 17
- ESD Protection Exceeds JESD 22
  - 2000-V Human-Body Model (A114-A)
  - 200-V Machine Model (A115-A)

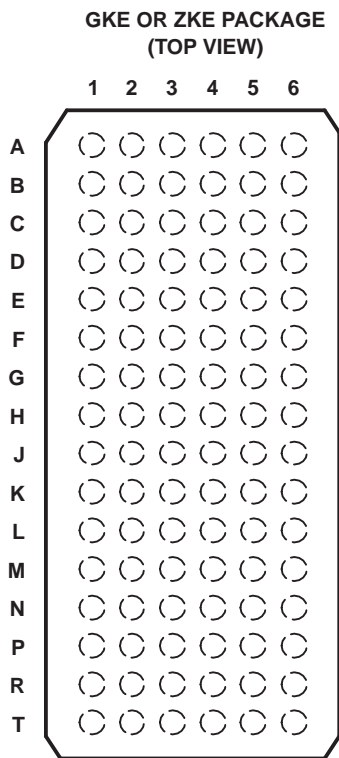

**TERMINAL ASSIGNMENTS**

	1	2	3	4	5	6
<b>A</b>	1Q2	1Q1	1 $\overline{OE}$	1CLK	1D1	1D2
<b>B</b>	1Q4	1Q3	GND	GND	1D3	1D4
<b>C</b>	1Q6	1Q5	V <sub>CC</sub>	V <sub>CC</sub>	1D5	1D6
<b>D</b>	1Q8	1Q7	GND	GND	1D7	1D8
<b>E</b>	2Q2	2Q1	GND	GND	2D1	2D2
<b>F</b>	2Q4	2Q3	V <sub>CC</sub>	V <sub>CC</sub>	2D3	2D4
<b>G</b>	2Q6	2Q5	GND	GND	2D5	2D6
<b>H</b>	2Q7	2Q8	2 $\overline{OE}$	2CLK	2D8	2D7
<b>J</b>	3Q2	3Q1	3 $\overline{OE}$	3CLK	3D1	3D2
<b>K</b>	3Q4	3Q3	GND	GND	3D3	3D4
<b>L</b>	3Q6	3Q5	V <sub>CC</sub>	V <sub>CC</sub>	3D5	3D6
<b>M</b>	3Q8	3Q7	GND	GND	3D7	3D8
<b>N</b>	4Q2	4Q1	GND	GND	4D1	4D2
<b>P</b>	4Q4	4Q3	V <sub>CC</sub>	V <sub>CC</sub>	4D3	4D4
<b>R</b>	4Q6	4Q5	GND	GND	4D5	4D6
<b>T</b>	4Q7	4Q8	4 $\overline{OE}$	4CLK	4D8	4D7

**DESCRIPTION/ORDERING INFORMATION**

**ORDERING INFORMATION**

T <sub>A</sub>	PACKAGE <sup>(1)</sup>		ORDERABLE PART NUMBER	TOP-SIDE MARKING
-40°C to 85°C	LFBGA – GKE	Reel of 1000	SN74LVTH322374KR	HW374
	LFBGA – ZKE (Pb-free)	Reel of 1000	74LVTH322374ZKER	HW374

(1) Package drawings, standard packing quantities, thermal data, symbolization, and PCB design guidelines are available at [www.ti.com/sc/package](http://www.ti.com/sc/package).



Please be aware that an important notice concerning availability, standard warranty, and use in critical applications of Texas Instruments semiconductor products and disclaimers thereto appears at the end of this data sheet.

Widebus+ is a trademark of Texas Instruments.

# SN74LVTH322374

## 3.3-V ABT 32-BIT EDGE-TRIGGERED D-TYPE FLIP-FLOP WITH 3-STATE OUTPUTS

SCBS754C—MARCH 2002—REVISED NOVEMBER 2006

### DESCRIPTION/ORDERING INFORMATION (CONTINUED)

The SN74LVTH322374 is a 32-bit edge-triggered D-type flip-flop with 3-state outputs designed for low-voltage (3.3-V)  $V_{CC}$  operation, but with the capability to provide a TTL interface to a 5-V system environment. It is particularly suitable for implementing buffer registers, I/O ports, bidirectional bus drivers, and working registers.

This device can be used as four 8-bit flip-flops, two 16-bit flip-flops, or one 32-bit flip-flop. On the positive transition of the clock (CLK), the Q outputs of the flip-flop take on the logic levels set up at the D inputs.

A buffered output-enable ( $\overline{OE}$ ) input can be used to place the eight outputs in either a normal logic state (high or low logic levels) or the high-impedance state. In the high-impedance state, the outputs neither load nor drive the bus lines significantly. The high-impedance state and the increased drive provide the capability to drive bus lines without need for interface or pullup components.

$\overline{OE}$  does not affect internal operations of the flip-flop. Old data can be retained or new data can be entered while the outputs are in the high-impedance state.

The outputs, which are designed to source or sink up to 12 mA, include equivalent 22- $\Omega$  series resistors to reduce overshoot and undershoot.

Active bus-hold circuitry holds unused or undriven inputs at a valid logic state. Use of pullup or pulldown resistors with the bus-hold circuitry is not recommended.

When  $V_{CC}$  is between 0 and 1.5 V, the devices are in the high-impedance state during power up or power down. However, to ensure the high-impedance state above 1.5 V,  $\overline{OE}$  should be tied to  $V_{CC}$  through a pullup resistor; the minimum value of the resistor is determined by the current-sinking capability of the driver.

This device is fully specified for hot-insertion applications using  $I_{off}$  and power-up 3-state. The  $I_{off}$  circuitry disables the outputs, preventing damaging current backflow through the device when it is powered down. The power-up 3-state circuitry places the outputs in the high-impedance state during power up and power down, which prevents driver conflict.

**FUNCTION TABLE**  
(each 8-bit flip-flop)

INPUTS			OUTPUT G
$\overline{OE}$	LE	D	
L	$\uparrow$	H	H
L	$\uparrow$	L	L
L	H or L	X	$Q_0$
H	X	X	Z

**LOGIC DIAGRAM (POSITIVE LOGIC)**

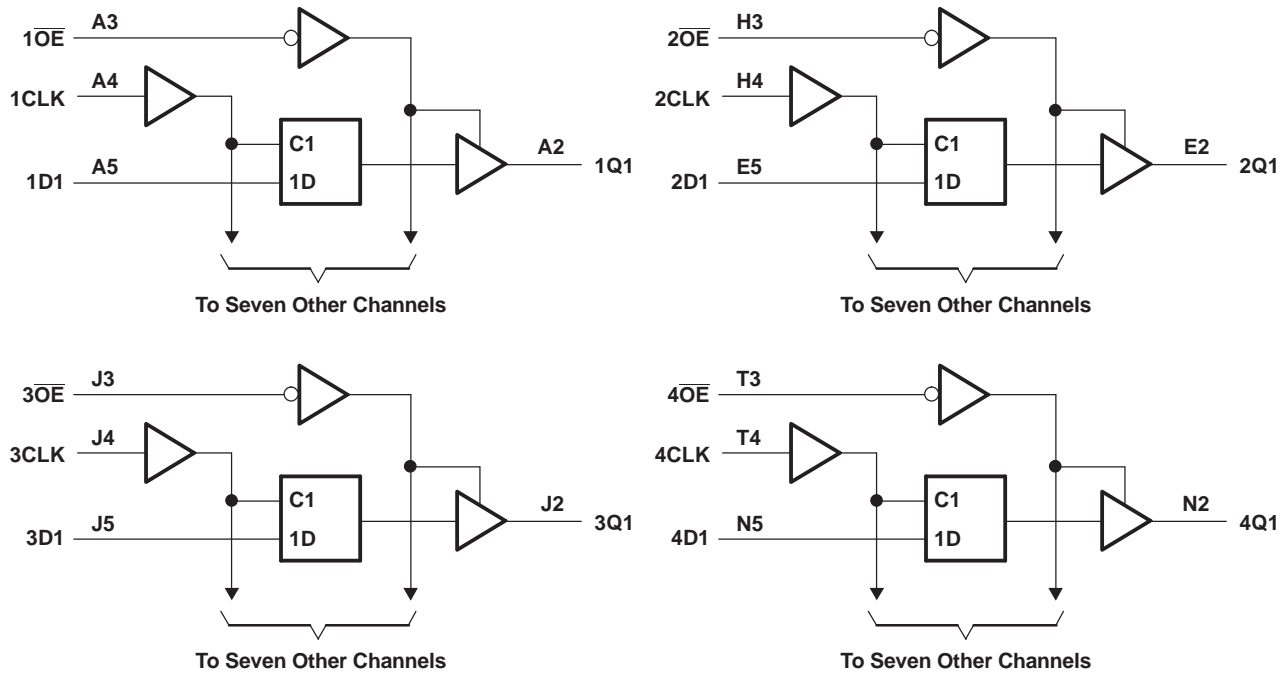

**Absolute Maximum Ratings<sup>(1)</sup>**

over operating free-air temperature range (unless otherwise noted)

		MIN	MAX	UNIT
$V_{CC}$	Supply voltage range	-0.5	4.6	V
$V_I$	Input voltage range <sup>(2)</sup>	-0.5	7	V
$V_O$	Voltage range applied to any output in the high-impedance or power-off state <sup>(2)</sup>	-0.5	7	V
$V_O$	Voltage range applied to any output in the high state <sup>(2)</sup>	-0.5	$V_{CC} + 0.5$	V
$I_O$	Current into any output in the low state		30	mA
$I_O$	Current into any output in the high state <sup>(3)</sup>		30	mA
$I_{IK}$	Input clamp current	$V_I < 0$	-50	mA
$I_{OK}$	Output clamp current	$V_O < 0$	-50	mA
$\theta_{JA}$	Package thermal impedance <sup>(4)</sup>		40	°C/W
$T_{stg}$	Storage temperature range	-65	150	°C

- (1) Stresses beyond those listed under "absolute maximum ratings" may cause permanent damage to the device. These are stress ratings only, and functional operation of the device at these or any other conditions beyond those indicated under "recommended operating conditions" is not implied. Exposure to absolute-maximum-rated conditions for extended periods may affect device reliability.
- (2) The input and output negative-voltage ratings may be exceeded if the input and output clamp-current ratings are observed.
- (3) This current flows only when the output is in the high state and  $V_O > V_{CC}$ .
- (4) The package thermal impedance is calculated in accordance with JESD 51-7.

**SN74LVTH322374**  
**3.3-V ABT 32-BIT EDGE-TRIGGERED D-TYPE**  
**FLIP-FLOP WITH 3-STATE OUTPUTS**

SCBS754C—MARCH 2002—REVISED NOVEMBER 2006

**Recommended Operating Conditions<sup>(1)</sup>**

		MIN	MAX	UNIT
V <sub>CC</sub>	Supply voltage	2.7	3.6	V
V <sub>IH</sub>	High-level input voltage	2		V
V <sub>IL</sub>	Low-level input voltage		0.8	V
V <sub>I</sub>	Input voltage		5.5	V
I <sub>OH</sub>	High-level output current		-12	mA
I <sub>OL</sub>	Low-level output current		12	mA
Δt/Δv	Input transition rise or fall rate		10	ns/V
				Outputs enabled
Δt/ΔV <sub>CC</sub>	Power-up ramp rate	200		μs/V
T <sub>A</sub>	Operating free-air temperature	-40	85	°C

(1) All unused inputs of the device must be held at V<sub>CC</sub> or GND to ensure proper device operation. Refer to the TI application report, *Implications of Slow or Floating CMOS Inputs*, literature number SCBA004.

**Electrical Characteristics**

over recommended operating free-air temperature range (unless otherwise noted)

PARAMETER		TEST CONDITIONS		MIN	TYP <sup>(1)</sup>	MAX	UNIT
V <sub>IK</sub>		V <sub>CC</sub> = 2.7 V,	I <sub>I</sub> = -18 mA			-1.2	V
V <sub>OH</sub>		V <sub>CC</sub> = 3 V,	I <sub>OH</sub> = -12 mA	2			V
V <sub>OL</sub>		V <sub>CC</sub> = 3 V,	I <sub>OL</sub> = 12 mA			0.8	V
I <sub>I</sub>		V <sub>CC</sub> = 0 or 3.6 V,	V <sub>I</sub> = 5.5 V			10	μA
	Control inputs	V <sub>CC</sub> = 3.6 V,	V <sub>I</sub> = V <sub>CC</sub> or GND			±1	
	Data inputs	V <sub>CC</sub> = 3.6 V	V <sub>I</sub> = V <sub>CC</sub>			1	
			V <sub>I</sub> = 0			-5	
I <sub>off</sub>		V <sub>CC</sub> = 0,	V <sub>I</sub> or V <sub>O</sub> = 0 to 4.5 V			±100	μA
I <sub>I(hold)</sub>	Data inputs	V <sub>CC</sub> = 3 V	V <sub>I</sub> = 0.8 V	75			μA
			V <sub>I</sub> = 2 V	-75			
		V <sub>CC</sub> = 3.6 V, <sup>(2)</sup>	V <sub>I</sub> = 0 to 3.6 V			500 -750	
I <sub>OZH</sub>		V <sub>CC</sub> = 3.6 V,	V <sub>O</sub> = 3 V			5	μA
I <sub>OZL</sub>		V <sub>CC</sub> = 3.6 V,	V <sub>O</sub> = 0.5 V			-5	μA
I <sub>OZPU</sub>		V <sub>CC</sub> = 0 to 1.5 V, V <sub>O</sub> = 0.5 V to 3 V, $\overline{OE}$ = don't care				±100	μA
I <sub>OZPD</sub>		V <sub>CC</sub> = 1.5 V to 0, V <sub>O</sub> = 0.5 V to 3 V, $\overline{OE}$ = don't care				±100	μA
I <sub>CC</sub>		V <sub>CC</sub> = 3.6 V, I <sub>O</sub> = 0, V <sub>I</sub> = V <sub>CC</sub> or GND	Outputs high			0.38	mA
			Outputs low			10	
			Outputs disabled			0.38	
ΔI <sub>CC</sub> <sup>(3)</sup>		V <sub>CC</sub> = 3 V to 3.6 V, One input at V <sub>CC</sub> - 0.6 V, Other inputs at V <sub>CC</sub> or GND				0.2	mA
C <sub>I</sub>		V <sub>I</sub> = 3 V or 0			3		pF
C <sub>O</sub>		V <sub>O</sub> = 3 V or 0			9		pF

(1) All typical values are at V<sub>CC</sub> = 3.3 V, T<sub>A</sub> = 25°C.

(2) This is the bus-hold maximum dynamic current. It is the minimum overdrive current required to switch the input from one state to another.

(3) This is the increase in supply current for each input that is at the specified TTL voltage level, rather than V<sub>CC</sub> or GND.

## Timing Requirements

over recommended operating free-air temperature range (unless otherwise noted) (see [Figure 1](#))

		$V_{CC} = 3.3\text{ V} \pm 0.3\text{ V}$		$V_{CC} = 2.7\text{ V}$		UNIT
		MIN	MAX	MIN	MAX	
$f_{\text{clock}}$	Clock frequency	160		160		MHz
$t_w$	Pulse duration, CLK high or low	3		3		ns
$t_{\text{su}}$	Setup time, data before CLK $\uparrow$	High or low		2		ns
$t_h$	Hold time, data after CLK $\uparrow$	High or low		0.1		ns

## Switching Characteristics

over recommended operating free-air temperature range (unless otherwise noted) (see [Figure 1](#))

PARAMETER	FROM (INPUT)	TO (OUTPUT)	$V_{CC} = 3.3\text{ V} \pm 0.3\text{ V}$			$V_{CC} = 2.7\text{ V}$		UNIT
			MIN	TYP <sup>(1)</sup>	MAX	MIN	MAX	
$f_{\text{max}}$			160			160		MHz
$t_{\text{PLH}}$	CLK	Q	2	3.4	5.3	6.2		ns
$t_{\text{PHL}}$			2.2	3.3	4.9	5.1		
$t_{\text{PZH}}$	$\overline{\text{OE}}$	Q	1.8	3.5	5.6	6.9		ns
$t_{\text{PZL}}$			1.8	3.5	4.9	6		
$t_{\text{PHZ}}$	$\overline{\text{OE}}$	Q	2.4	4.2	5.4	5.7		ns
$t_{\text{PLZ}}$			2	3.8	5	5.1		
$t_{\text{sk(LH)}}$					0.5			ns
$t_{\text{sk(HL)}}$					0.5			

(1) All typical values are at  $V_{CC} = 3.3\text{ V}$ ,  $T_A = 25^\circ\text{C}$ .

PARAMETER MEASUREMENT INFORMATION

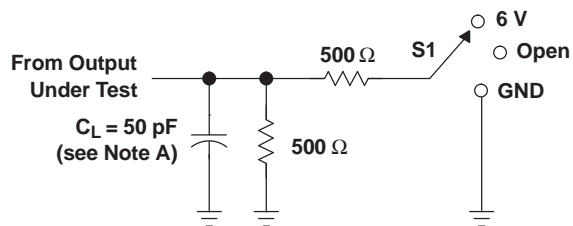

LOAD CIRCUIT

TEST	S1
$t_{PLH}/t_{PHL}$	Open
$t_{PLZ}/t_{PZL}$	6 V
$t_{PHZ}/t_{PZH}$	GND

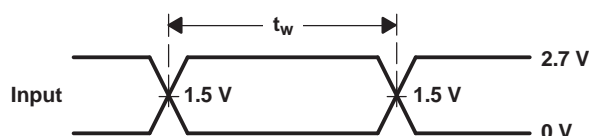

VOLTAGE WAVEFORMS  
 PULSE DURATION

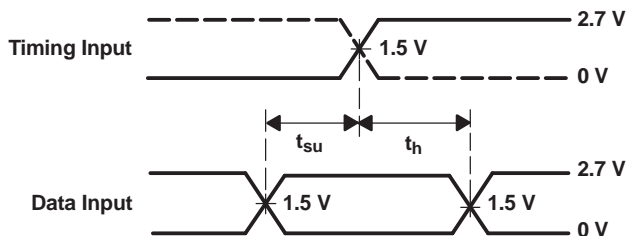

VOLTAGE WAVEFORMS  
 SETUP AND HOLD TIMES

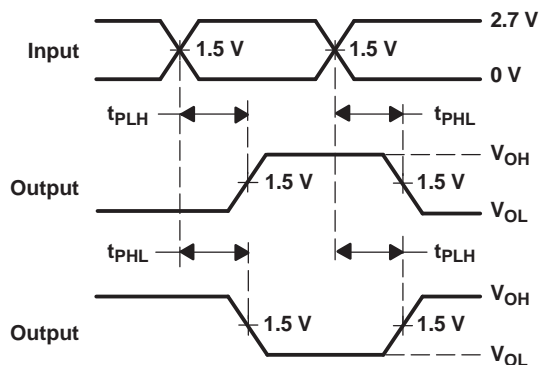

VOLTAGE WAVEFORMS  
 PROPAGATION DELAY TIMES  
 INVERTING AND NONINVERTING OUTPUTS

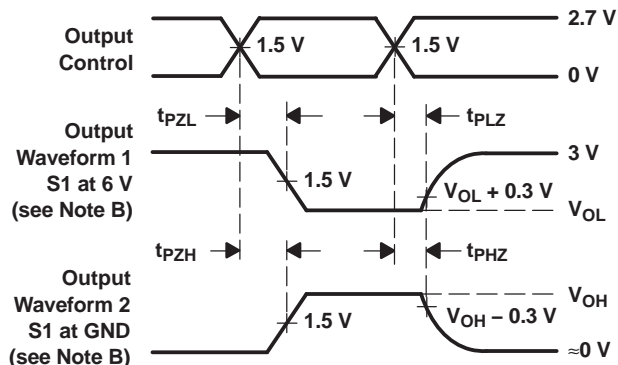

VOLTAGE WAVEFORMS  
 ENABLE AND DISABLE TIMES  
 LOW- AND HIGH-LEVEL ENABLING

- NOTES: A.  $C_L$  includes probe and jig capacitance.  
 B. Waveform 1 is for an output with internal conditions such that the output is low, except when disabled by the output control. Waveform 2 is for an output with internal conditions such that the output is high, except when disabled by the output control.  
 C. All input pulses are supplied by generators having the following characteristics: PRR  $\leq 10 \text{ MHz}$ ,  $Z_O = 50 \Omega$ ,  $t_r \leq 2.5 \text{ ns}$ ,  $t_f \leq 2.5 \text{ ns}$ .  
 D. The outputs are measured one at a time, with one transition per measurement.

Figure 1. Load Circuit and Voltage Waveforms

**PACKAGING INFORMATION**

Orderable Device	Status (1)	Package Type	Package Drawing	Pins	Package Qty	Eco Plan (2)	Lead/Ball Finish	MSL Peak Temp (3)	Op Temp (°C)	Top-Side Markings (4)	Samples
74LVTH322374ZKER	ACTIVE	LFBGA	ZKE	96	1000	Green (RoHS & no Sb/Br)	SNAGCU	Level-3-260C-168 HR	-40 to 85	HW374	<a href="#">Samples</a>
SN74LVTH322374KR	NRND	LFBGA	GKE	96	1000	TBD	SNPB	Level-2-235C-1 YEAR	-40 to 85	HW374	

(1) The marketing status values are defined as follows:

**ACTIVE:** Product device recommended for new designs.

**LIFEBUY:** TI has announced that the device will be discontinued, and a lifetime-buy period is in effect.

**NRND:** Not recommended for new designs. Device is in production to support existing customers, but TI does not recommend using this part in a new design.

**PREVIEW:** Device has been announced but is not in production. Samples may or may not be available.

**OBSOLETE:** TI has discontinued the production of the device.

(2) Eco Plan - The planned eco-friendly classification: Pb-Free (RoHS), Pb-Free (RoHS Exempt), or Green (RoHS & no Sb/Br) - please check <http://www.ti.com/productcontent> for the latest availability information and additional product content details.

**TBD:** The Pb-Free/Green conversion plan has not been defined.

**Pb-Free (RoHS):** TI's terms "Lead-Free" or "Pb-Free" mean semiconductor products that are compatible with the current RoHS requirements for all 6 substances, including the requirement that lead not exceed 0.1% by weight in homogeneous materials. Where designed to be soldered at high temperatures, TI Pb-Free products are suitable for use in specified lead-free processes.

**Pb-Free (RoHS Exempt):** This component has a RoHS exemption for either 1) lead-based flip-chip solder bumps used between the die and package, or 2) lead-based die adhesive used between the die and leadframe. The component is otherwise considered Pb-Free (RoHS compatible) as defined above.

**Green (RoHS & no Sb/Br):** TI defines "Green" to mean Pb-Free (RoHS compatible), and free of Bromine (Br) and Antimony (Sb) based flame retardants (Br or Sb do not exceed 0.1% by weight in homogeneous material)

(3) MSL, Peak Temp. -- The Moisture Sensitivity Level rating according to the JEDEC industry standard classifications, and peak solder temperature.

(4) Multiple Top-Side Markings will be inside parentheses. Only one Top-Side Marking contained in parentheses and separated by a "~" will appear on a device. If a line is indented then it is a continuation of the previous line and the two combined represent the entire Top-Side Marking for that device.

**Important Information and Disclaimer:**The information provided on this page represents TI's knowledge and belief as of the date that it is provided. TI bases its knowledge and belief on information provided by third parties, and makes no representation or warranty as to the accuracy of such information. Efforts are underway to better integrate information from third parties. TI has taken and continues to take reasonable steps to provide representative and accurate information but may not have conducted destructive testing or chemical analysis on incoming materials and chemicals. TI and TI suppliers consider certain information to be proprietary, and thus CAS numbers and other limited information may not be available for release.

In no event shall TI's liability arising out of such information exceed the total purchase price of the TI part(s) at issue in this document sold by TI to Customer on an annual basis.

**TAPE AND REEL INFORMATION**

**QUADRANT ASSIGNMENTS FOR PIN 1 ORIENTATION IN TAPE**

\*All dimensions are nominal

Device	Package Type	Package Drawing	Pins	SPQ	Reel Diameter (mm)	Reel Width W1 (mm)	A0 (mm)	B0 (mm)	K0 (mm)	P1 (mm)	W (mm)	Pin1 Quadrant
74LVTH322374ZKER	LFBGA	ZKE	96	1000	330.0	24.4	5.7	13.7	2.0	8.0	24.0	Q1
SN74LVTH322374KR	LFBGA	GKE	96	1000	330.0	24.4	5.7	13.7	2.0	8.0	24.0	Q1



**TAPE AND REEL BOX DIMENSIONS**

\*All dimensions are nominal

Device	Package Type	Package Drawing	Pins	SPQ	Length (mm)	Width (mm)	Height (mm)
74LVTH322374ZKER	LFBGA	ZKE	96	1000	336.6	336.6	41.3
SN74LVTH322374KR	LFBGA	GKE	96	1000	336.6	336.6	41.3

GKE (R-PBGA-N96)

PLASTIC BALL GRID ARRAY

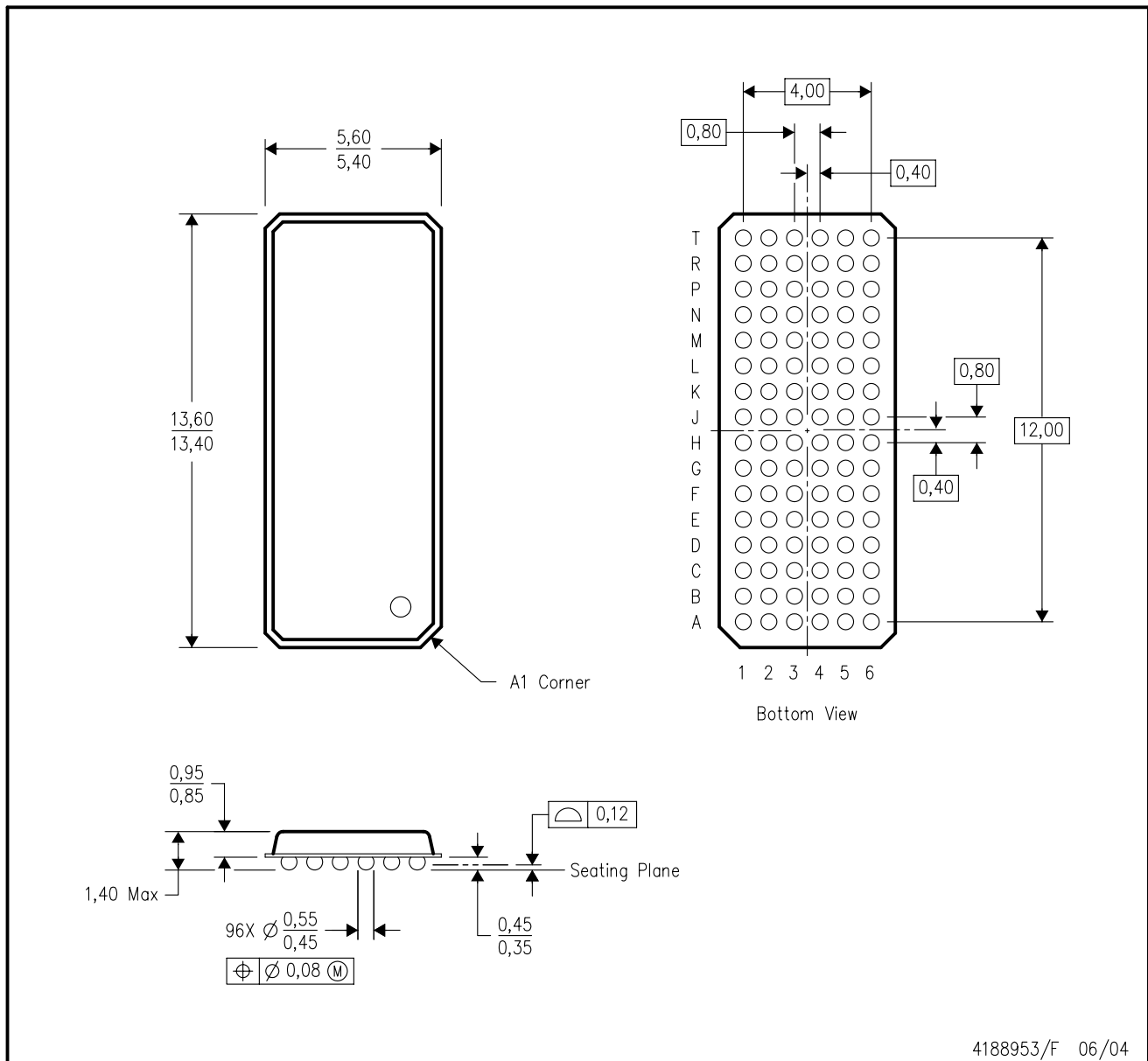

4188953/F 06/04

- NOTES:
- A. All linear dimensions are in millimeters.
  - B. This drawing is subject to change without notice.
  - C. Falls within JEDEC MO-205 variation CC.
  - D. This package is tin-lead (SnPb). Refer to the 96 ZKE package (drawing 4204493) for lead-free.

ZKE (R-PBGA-N96)

PLASTIC BALL GRID ARRAY

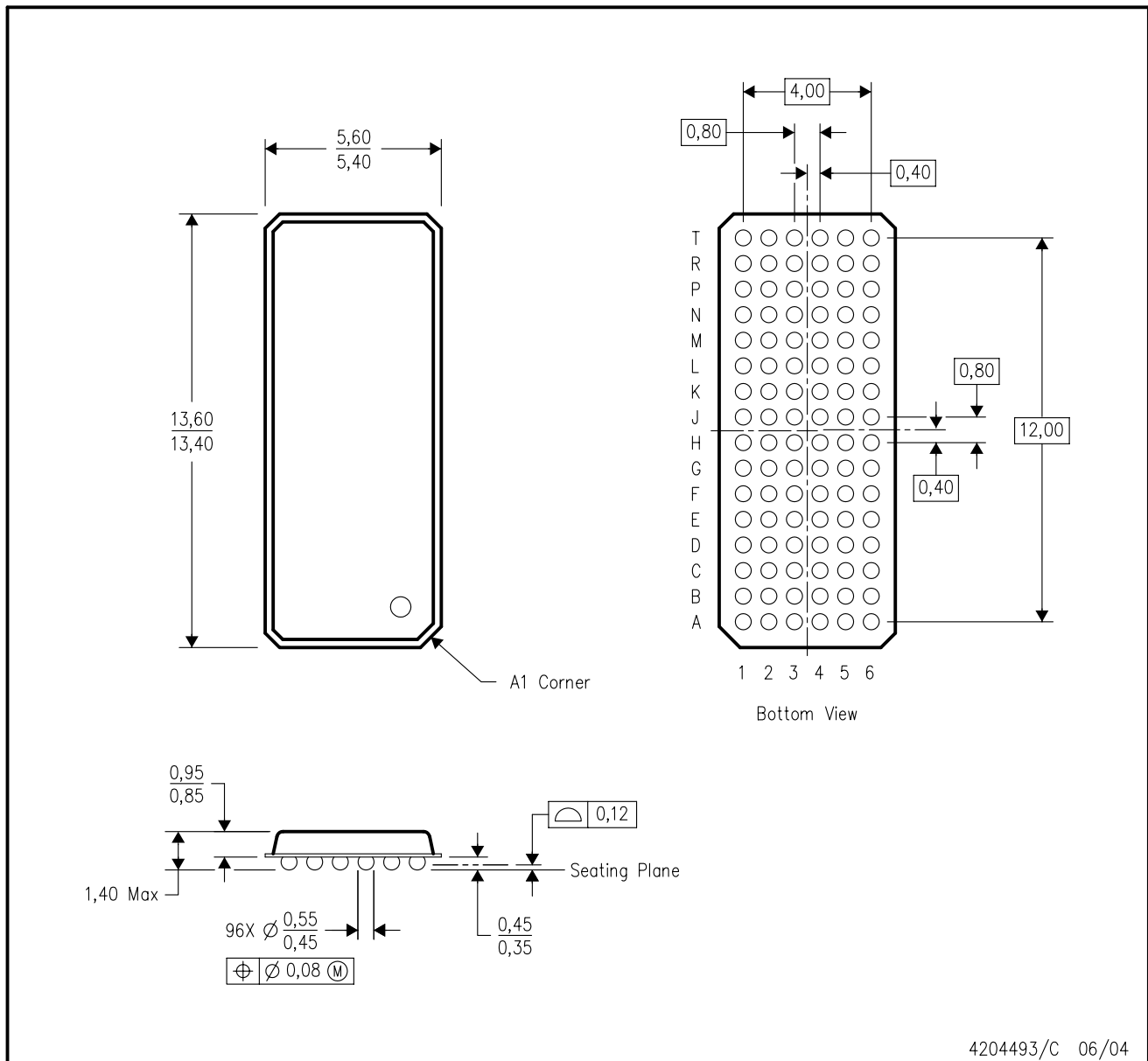

4204493/C 06/04

- NOTES:
- A. All linear dimensions are in millimeters.
  - B. This drawing is subject to change without notice.
  - C. Falls within JEDEC MO-205 variation CC.
  - D. This package is lead-free. Refer to the 96 GKE package (drawing 4188953) for tin-lead (SnPb).

## IMPORTANT NOTICE

Texas Instruments Incorporated and its subsidiaries (TI) reserve the right to make corrections, enhancements, improvements and other changes to its semiconductor products and services per JESD46, latest issue, and to discontinue any product or service per JESD48, latest issue. Buyers should obtain the latest relevant information before placing orders and should verify that such information is current and complete. All semiconductor products (also referred to herein as "components") are sold subject to TI's terms and conditions of sale supplied at the time of order acknowledgment.

TI warrants performance of its components to the specifications applicable at the time of sale, in accordance with the warranty in TI's terms and conditions of sale of semiconductor products. Testing and other quality control techniques are used to the extent TI deems necessary to support this warranty. Except where mandated by applicable law, testing of all parameters of each component is not necessarily performed.

TI assumes no liability for applications assistance or the design of Buyers' products. Buyers are responsible for their products and applications using TI components. To minimize the risks associated with Buyers' products and applications, Buyers should provide adequate design and operating safeguards.

TI does not warrant or represent that any license, either express or implied, is granted under any patent right, copyright, mask work right, or other intellectual property right relating to any combination, machine, or process in which TI components or services are used. Information published by TI regarding third-party products or services does not constitute a license to use such products or services or a warranty or endorsement thereof. Use of such information may require a license from a third party under the patents or other intellectual property of the third party, or a license from TI under the patents or other intellectual property of TI.

Reproduction of significant portions of TI information in TI data books or data sheets is permissible only if reproduction is without alteration and is accompanied by all associated warranties, conditions, limitations, and notices. TI is not responsible or liable for such altered documentation. Information of third parties may be subject to additional restrictions.

Resale of TI components or services with statements different from or beyond the parameters stated by TI for that component or service voids all express and any implied warranties for the associated TI component or service and is an unfair and deceptive business practice. TI is not responsible or liable for any such statements.

Buyer acknowledges and agrees that it is solely responsible for compliance with all legal, regulatory and safety-related requirements concerning its products, and any use of TI components in its applications, notwithstanding any applications-related information or support that may be provided by TI. Buyer represents and agrees that it has all the necessary expertise to create and implement safeguards which anticipate dangerous consequences of failures, monitor failures and their consequences, lessen the likelihood of failures that might cause harm and take appropriate remedial actions. Buyer will fully indemnify TI and its representatives against any damages arising out of the use of any TI components in safety-critical applications.

In some cases, TI components may be promoted specifically to facilitate safety-related applications. With such components, TI's goal is to help enable customers to design and create their own end-product solutions that meet applicable functional safety standards and requirements. Nonetheless, such components are subject to these terms.

No TI components are authorized for use in FDA Class III (or similar life-critical medical equipment) unless authorized officers of the parties have executed a special agreement specifically governing such use.

Only those TI components which TI has specifically designated as military grade or "enhanced plastic" are designed and intended for use in military/aerospace applications or environments. Buyer acknowledges and agrees that any military or aerospace use of TI components which have **not** been so designated is solely at the Buyer's risk, and that Buyer is solely responsible for compliance with all legal and regulatory requirements in connection with such use.

TI has specifically designated certain components as meeting ISO/TS16949 requirements, mainly for automotive use. In any case of use of non-designated products, TI will not be responsible for any failure to meet ISO/TS16949.

### Products

Audio	<a href="http://www.ti.com/audio">www.ti.com/audio</a>
Amplifiers	<a href="http://amplifier.ti.com">amplifier.ti.com</a>
Data Converters	<a href="http://dataconverter.ti.com">dataconverter.ti.com</a>
DLP® Products	<a href="http://www.dlp.com">www.dlp.com</a>
DSP	<a href="http://dsp.ti.com">dsp.ti.com</a>
Clocks and Timers	<a href="http://www.ti.com/clocks">www.ti.com/clocks</a>
Interface	<a href="http://interface.ti.com">interface.ti.com</a>
Logic	<a href="http://logic.ti.com">logic.ti.com</a>
Power Mgmt	<a href="http://power.ti.com">power.ti.com</a>
Microcontrollers	<a href="http://microcontroller.ti.com">microcontroller.ti.com</a>
RFID	<a href="http://www.ti-rfid.com">www.ti-rfid.com</a>
OMAP Applications Processors	<a href="http://www.ti.com/omap">www.ti.com/omap</a>
Wireless Connectivity	<a href="http://www.ti.com/wirelessconnectivity">www.ti.com/wirelessconnectivity</a>

### Applications

Automotive and Transportation	<a href="http://www.ti.com/automotive">www.ti.com/automotive</a>
Communications and Telecom	<a href="http://www.ti.com/communications">www.ti.com/communications</a>
Computers and Peripherals	<a href="http://www.ti.com/computers">www.ti.com/computers</a>
Consumer Electronics	<a href="http://www.ti.com/consumer-apps">www.ti.com/consumer-apps</a>
Energy and Lighting	<a href="http://www.ti.com/energy">www.ti.com/energy</a>
Industrial	<a href="http://www.ti.com/industrial">www.ti.com/industrial</a>
Medical	<a href="http://www.ti.com/medical">www.ti.com/medical</a>
Security	<a href="http://www.ti.com/security">www.ti.com/security</a>
Space, Avionics and Defense	<a href="http://www.ti.com/space-avionics-defense">www.ti.com/space-avionics-defense</a>
Video and Imaging	<a href="http://www.ti.com/video">www.ti.com/video</a>

### TI E2E Community

[e2e.ti.com](http://e2e.ti.com)