

SN75164B

OCTAL GENERAL-PURPOSE INTERFACE BUS TRANSCEIVER

SLLS011A – OCTOBER 1985 – REVISED FEBRUARY 1993

- **8-Channel Bidirectional Transceiver**
- **Power-Up/Power-Down Protection (Glitch Free)**
- **ATN+EOI (OR Function) Output to Simplify Board Layout**
- **Designed to Implement Control Bus Interface for Multiple Controllers**
- **Low-Power Dissipation . . . 72 mW Max Per Channel**
- **Fast Propagation Times . . . 22 ns Max**
- **High-impedance PNP Inputs**
- **Receiver Hysteresis . . . 650 mV Typ**
- **Bus-Terminating Resistors Provided on Driver Outputs**
- **No Loading of Bus When Device Is Powered Down ($V_{CC} = 0$)**

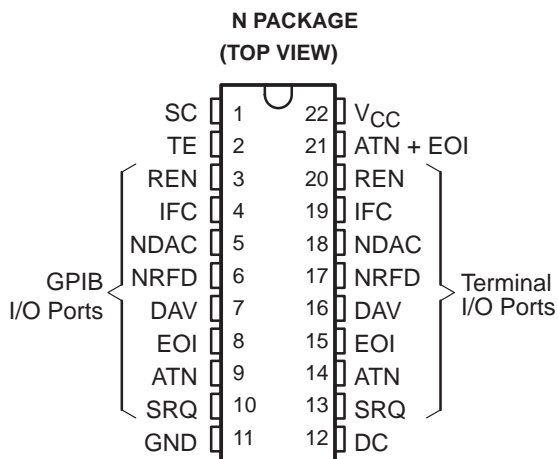

NC – No internal connection

NOT RECOMMENDED FOR NEW DESIGN

description

The SN75164B eight-channel general-purpose interface bus transceiver is a monolithic, high-speed, low-power Schottky device designed to meet the requirements of IEEE Standard 488-1978. Each transceiver is designed to provide the bus-management and data-transfer signals between operating units of a multiple-controller instrumentation system. When combined with the SN75160B octal bus transceiver, the SN75164B provides the complete 16-wire interface for the IEEE-488 bus.

The SN75164B features eight driver-receiver pairs connected in a front-to-back configuration to form input/output (I/O) ports at both the bus and terminal sides. All outputs are disabled (at a high-impedance state) during V_{CC} power-up and power-down transitions for glitch-free operation. The direction of data flow through these driver-receiver pairs is determined by the DC, TE, and SC enable signals. The SN75164B is identical to the SN75162B with the addition of an OR gate to help simplify board layouts in several popular applications. The ATN and EOI signals are ORed to pin 21, which is a standard totem-pole output.

CHANNEL IDENTIFICATION TABLE

NAME	IDENTITY	CLASS
DC TE SC	Direction Control Talk Enable System Control	Control
ATN SRQ REN IFC EOI	Attention Service Request Remote Enable Interface Clear End or Identify	Bus Management
ATN + EOI	ATN Logical or EOI	Logic
DAV NDAC NRFD	Data Valid Not Data Accepted Not Ready for Data	Data Transfer

SN75164B OCTAL GENERAL-PURPOSE INTERFACE BUS TRANSCEIVER

SLLS011A – OCTOBER 1985 – REVISED FEBRUARY 1993

description (continued)

The driver outputs (GPIB I/O ports) feature active bus-terminating resistor circuits designed to provide a high impedance to the bus when supply voltage V_{CC} is 0. The drivers are designed to handle loads up to 48 mA sink current. Each receiver features pnp transistor inputs for high input impedance and an ensured hysteresis of 400 mV for increased noise immunity. All receivers have 3-state outputs to present a high impedance to the terminal when disabled.

The SN75164B is characterized for operation from 0°C to 70°C.

logic symbol†

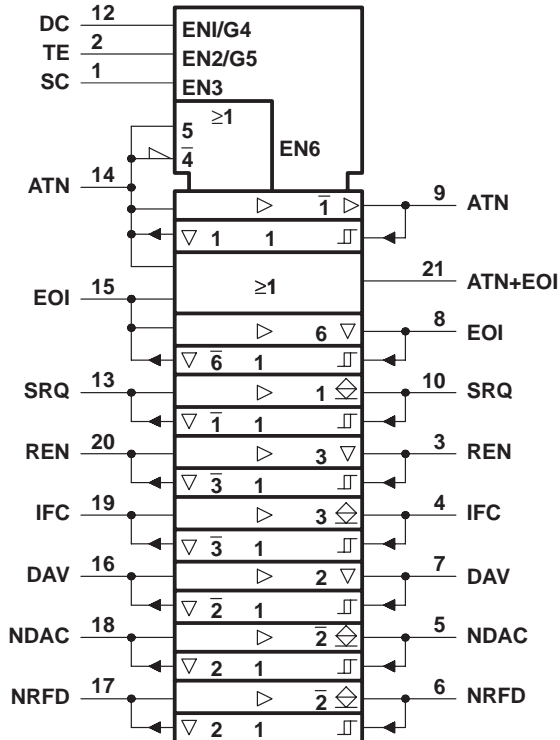

† This symbol is in accordance with ANSI/IEEE Std 91-1984 and IEC Publication 617-12

logic diagram (positive logic)

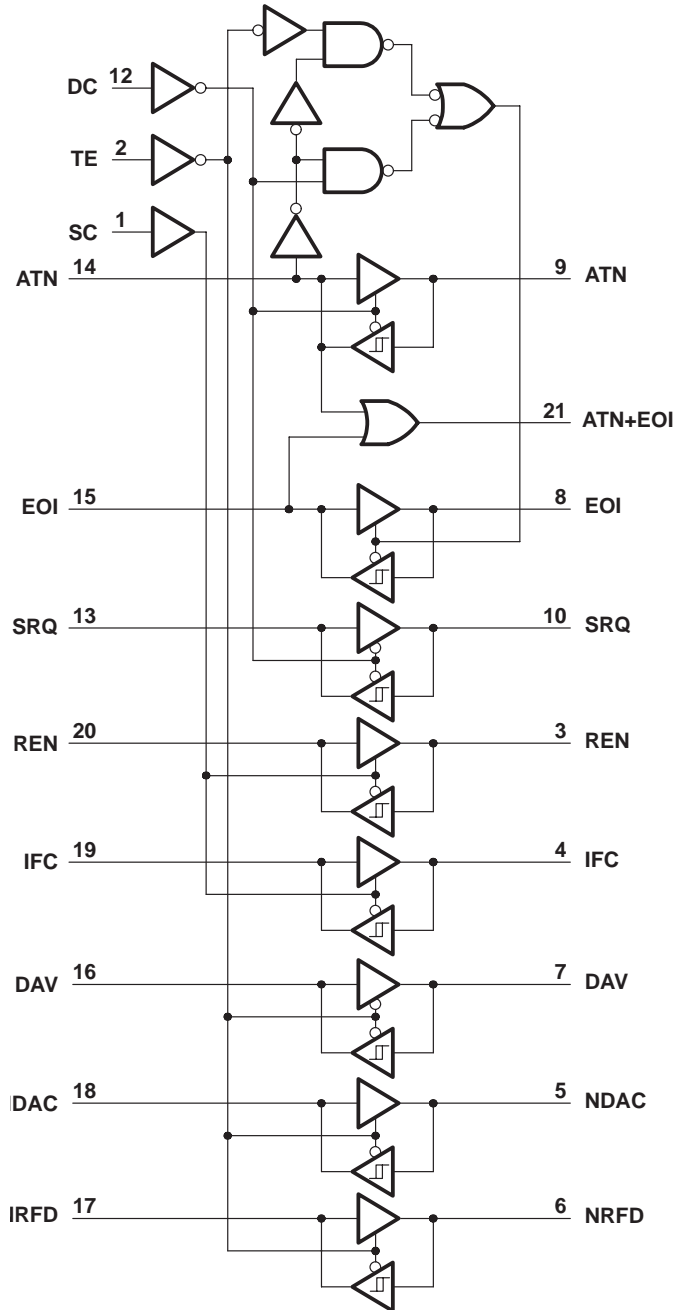

SN75164B

OCTAL GENERAL-PURPOSE INTERFACE BUS TRANSCEIVER

SLLS011A – OCTOBER 1985 – REVISED FEBRUARY 1993

RECEIVE/TRANSMIT FUNCTION TABLE

CONTROLS				BUS-MANAGEMENT CHANNELS				DATA-TRANSFER CHANNELS				
SC	DC	TE	ATN†	ATN†	SRQ	REN	IFC	EOI	DAV	NDAC	NRFD	
				(controlled by DC)		(controlled by SC)			(controlled by TE)			
	H	H	H	R	T				T	T	R	R
	H	H	L						R			
	L	L	H	T	R				R	T	T	
	L	L	L						T			
	H	L	X	R	T				R	T	T	
	L	H	X	T	R				T	R	R	
H						T	T					
L						R	R					

H = high level, L = low level, R = receive, T = transmit, X = irrelevant

Direction of data transmission is from the terminal side to the bus side, and the direction of data receiving is from the bus side to the terminal side. Data transfer is noninverting in both directions.

† ATN is a normal transceiver channel that functions additionally as an internal direction control or talk enable for EOI whenever the DC and TE inputs are in the same state. When DC and TE are in opposite states, the ATN channel functions as an independent transceiver only.

ATN + EOI FUNCTION TABLE

INPUTS		OUTPUT ATN+EOI
ATN	EOI	
H	X	H
X	H	H
L	L	L

SN75164B OCTAL GENERAL-PURPOSE INTERFACE BUS TRANSCEIVER

SLLS011A – OCTOBER 1985 – REVISED FEBRUARY 1993

schematics of inputs and outputs

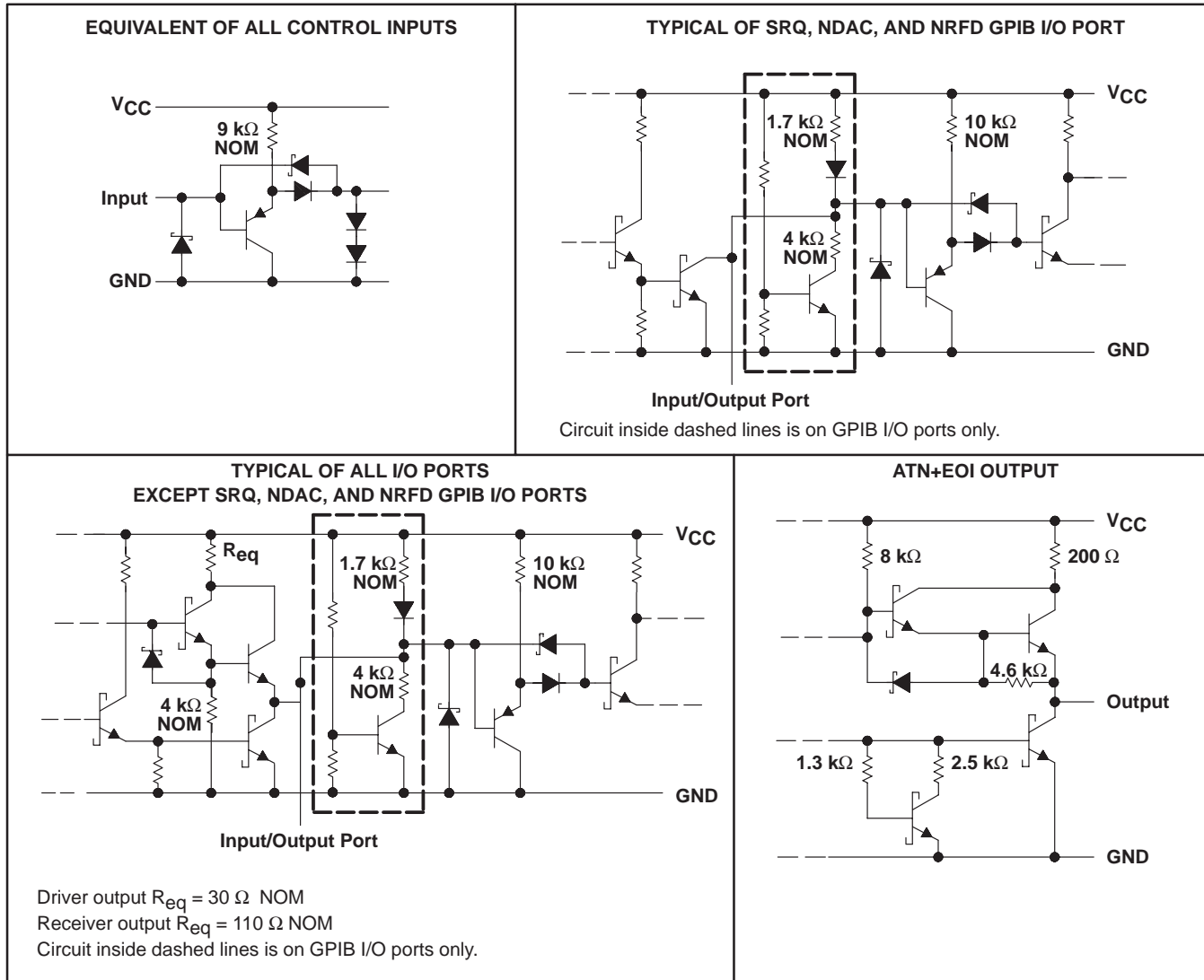

absolute maximum ratings over operating free-air temperature range (unless otherwise noted)

Supply voltage, V_{CC} (see Note 1)	7 V
Input voltage, V_I	5.5 V
Low-level driver output current	100 mA
Continuous total dissipation at (or below) 25°C free-air temperature (see Note 2)	1700 mW
Operating free-air temperature range	0°C to 70°C
Storage temperature range	-65°C to 150°C
Lead temperature 1,6 mm (1/16 inch) from case for 10 seconds: DW or N package	260°C

- NOTES: 1. All voltage values are with respect to network ground terminal.
2. For operation above 25°C free-air temperature, derate the N package at the rate of 13.6 mW/°C.

SN75164B

OCTAL GENERAL-PURPOSE INTERFACE BUS TRANSCEIVER

SLLS011A – OCTOBER 1985 – REVISED FEBRUARY 1993

recommended operating conditions

		MIN	NOM	MAX	UNIT
Supply voltage, V_{CC}		4.75	5	5.25	V
High-level Input voltage, V_{IH}		2			V
Low-level Input voltage, V_{IL}		0.8			V
High-level output current, I_{OH}	Bus ports with 3-state outputs	-5.2			mA
	Terminal ports	-800			μ A
	ATN+EOI	-400			
Low-level output current, I_{OL}	Bus ports	48			mA
	Terminal ports	16			
	ATN+EOI	4			
Operating free-air temperature, T_A		0	70		$^{\circ}$ C

electrical characteristics over recommended ranges of supply voltage and operating free-air temperature (unless otherwise noted)

PARAMETER		TEST CONDITIONS		MIN	TYP [†]	MAX	UNIT
V_{IK}	Input clamp voltage	$I_I = -18$ mA		-1.5		V	
V_{hys}	Hysteresis ($V_{T+} - V_{T-}$)	Bus	See Figure 8	0.4		V	
V_{OH}^{\ddagger}	High-level output voltage	Terminal	$I_{OH} = -800$ μ A	2.7		V	
		Bus	$I_{OH} = -5.2$ mA	2.5			
		ATN+EOI	$I_{OH} = -400$ μ A	2.7			
V_{OL}	Low-level output voltage	Terminal	$I_{OL} = 16$ mA	0.5		V	
		Bus	$I_{OL} = 48$ mA	0.5			
		ATN+EOI	$I_{OL} = 4$ mA	0.4			
I_I	Input current at maximum input voltage	Terminal [§]	$V_I = 5.5$ V	100		μ A	
		ATN+EOI	$V_I = 5.5$ V	200			
I_{IH}	High-level input current	Terminal, control	$V_I = 2.7$ V	20		μ A	
		ATN, EOI	$V_I = 2.7$ V	40			
I_{IL}	Low-level input current	Terminal, control	$V_I = 0.5$ V	-100		μ A	
		ATN, EOI	$V_I = 0.5$ V	-500			
$V_{I/O}(\text{bus})$	Voltage at bus port	Driver disabled	$I_I(\text{bus}) = 0$	2.5	3.7		V
			$I_I(\text{bus}) = -12$ mA	-1.5			
$I_{I/O}(\text{bus})$	Current into bus port	Power on	Driver disabled	$V_I(\text{bus}) = -1.5$ V to 0.4 V	-1.3		mA
				$V_I(\text{bus}) = 0.4$ V to 2.5 V	0		
				$V_I(\text{bus}) = 2.5$ V to 3.7 V	+2.5		
		$V_I(\text{bus}) = 3.7$ V to 5 V	0				
		$V_I(\text{bus}) = 5$ V to 5.5 V	0.7				
		$V_I(\text{bus}) = 5.5$ V to 5.5 V	2.5				
Power off	$V_{CC} = 0$,	$V_I(\text{bus}) = 0$ V to 2.5 V	-40		μ A		
I_{OS}	Short-circuit output current	Terminal	-15		-75	mA	
		Bus	-25		-125		
		ATN+EOI	-10		-100		
I_{CC}	Supply current	No load, TE, DE, and SC low		120		mA	
$C_{I/O}(\text{bus})$	Bus-port capacitance	$V_{CC} = 5$ V to 0 V, $V_{I/O} = 0$ to 2 V, $f = 1$ MHz		30		pF	

[†] All typical values are at $V_{CC} = 5$ V, $T_A = 25^{\circ}$ C.

[‡] V_{OH} applies for 3-state outputs only.

[§] Except ATN and EOI terminal pins



SN75164B

OCTAL GENERAL-PURPOSE INTERFACE BUS TRANSCEIVER

SLLS011A – OCTOBER 1985 – REVISED FEBRUARY 1993

switching characteristics, $V_{CC} = 5\text{ V}$, $C_L = 15\text{ pF}$, $T_A = 25^\circ\text{C}$ (unless otherwise noted)

PARAMETER	FROM (INPUT)	TO (OUTPUT)	TEST CONDITIONS	MIN	TYP	MAX	UNIT
t _{PLH} Propagation delay time, low-to-high level output	Terminal	Bus	C _L = 30 pF, See Figure 1		14	20	ns
t _{PHL} Propagation delay time, high-to-low level output					14	20	
t _{PLH} Propagation delay time, low-to-high level output	Terminal	Bus (SRQ, NDAC, NRFD)	C _L = 30 pF, See Figure 1		29	35	ns
t _{PLH} Propagation delay time, low-to-high level output	Bus	Terminal	C _L = 30 pF, See Figure 2		10	20	ns
t _{PHL} Propagation delay time, high-to-low level output					15	22	
t _{PLH} Propagation delay time, low-to-high level output	Terminal ATN or Terminal EOI	ATN+EOI	See Figure 3		14		ns
t _{PHL} Propagation delay time, high-to-low level output	Terminal ATN or Terminal EOI	ATN+EOI	See Figure 3		14		ns
t _{PZH} Output enable time to high level	TE, DC, or SC	Bus (ATN, EOI, REN, IFC, and DAV)	See Figure 4			60	ns
t _{PHZ} Output disable time from high level						45	
t _{PZL} Output enable time to low level						60	
t _{PLZ} Output disable time from low level						55	
t _{PZH} Output enable time to high level	TE, DC, or SC	Terminal	See Figure 5			55	ns
t _{PHZ} Output disable time from high level						50	
t _{PZL} Output enable time to low level						45	
t _{PLZ} Output disable time from low level						55	



PARAMETER MEASUREMENT INFORMATION

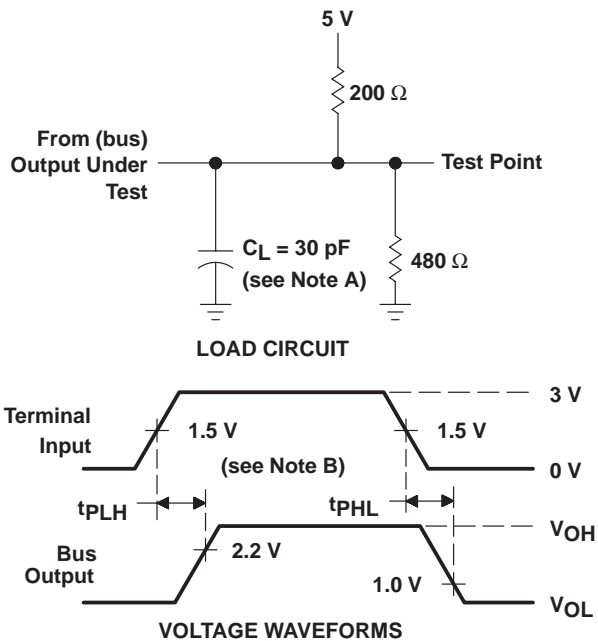

NOTES: A. C_L includes probe and jig capacitance.
B. The input pulse is supplied by a generator having the following characteristics: $PRR \leq 1$ MHz, 50% duty cycle, $t_r \leq 6$ ns, $t_f \leq$ ns, $Z_0 = 50 \Omega$.

Figure 1. Terminal-to-Bus Load Circuit and Voltage Waveforms

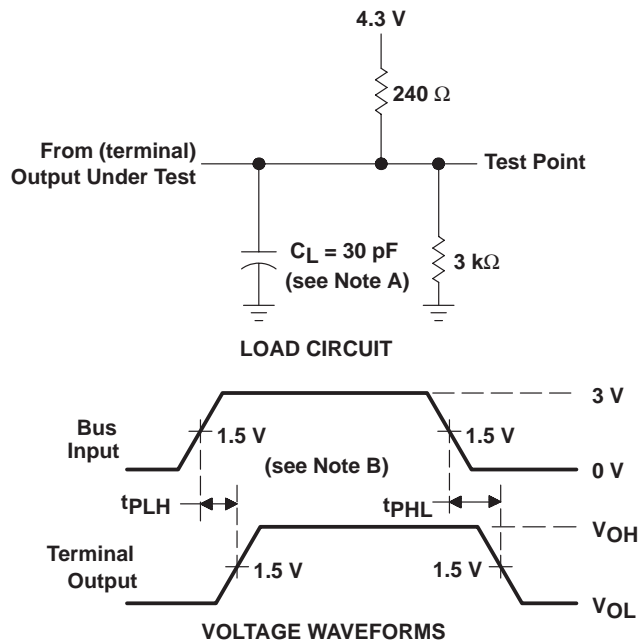

NOTES: A. C_L includes probe and jig capacitance.
B. The input pulse is supplied by a generator having the following characteristics: $PRR \leq 1$ MHz, 50% duty cycle, $t_r \leq 6$ ns, $t_f \leq$ ns, $Z_0 = 50 \Omega$.

Figure 2. Bus-to-Terminal Load Circuit and Voltage Waveforms

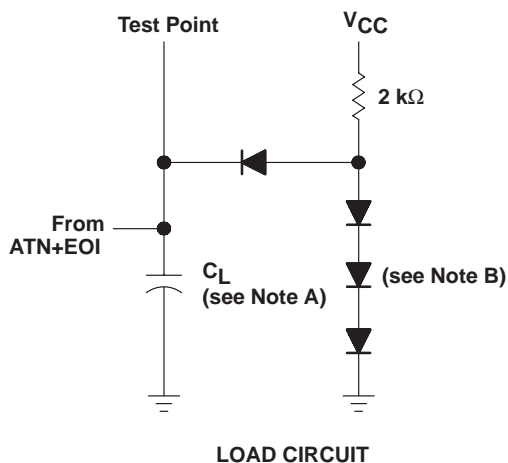

NOTES: A. C_L includes probe and jig capacitance.
B. All diodes are 1N916 or 1N3064.

Figure 3. ATN+EOI Load Circuit and Voltage Waveforms

SN75164B OCTAL GENERAL-PURPOSE INTERFACE BUS TRANSCEIVER

SLLS011A – OCTOBER 1985 – REVISED FEBRUARY 1993

PARAMETER MEASUREMENT INFORMATION

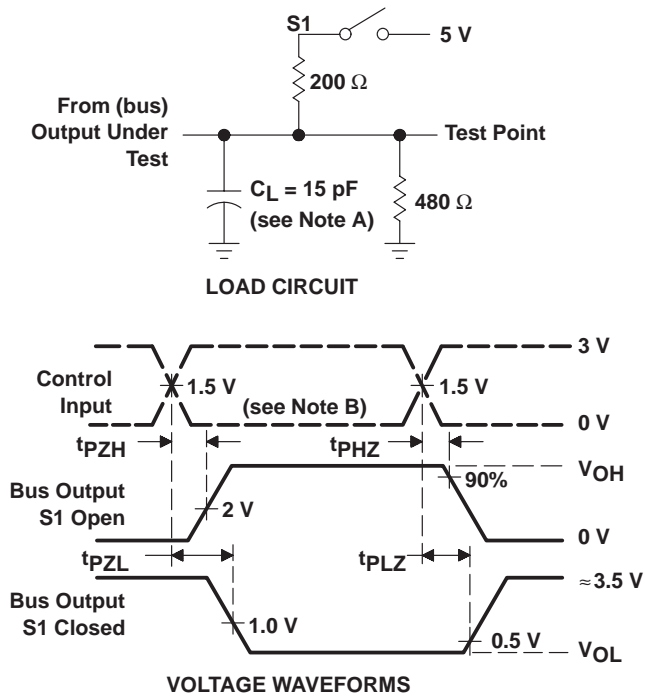

- NOTES: A. C_L includes probe and jig capacitance.
 B. The input pulse is supplied by a generator having the following characteristics: $PRR \leq 1$ MHz, 50% duty cycle, $t_r \leq 6$ ns, $t_f \leq 6$ ns, $Z_O = 50 \Omega$.

Figure 4. Bus Enable and Disable Times Load Circuit and Voltage Waveforms

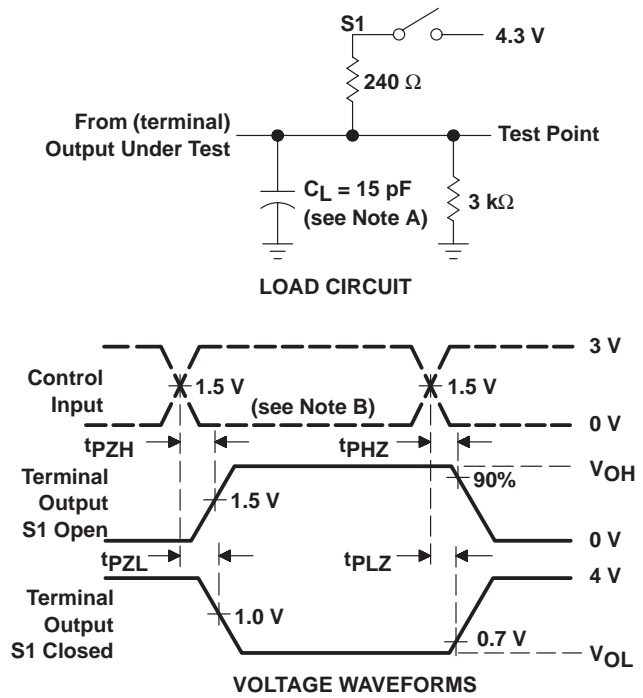

- NOTES: A. C_L includes probe and jig capacitance.
 B. The input pulse is supplied by a generator having the following characteristics: $PRR \leq 1$ MHz, 50% duty cycle, $t_r \leq 6$ ns, $t_f \leq 6$ ns, $Z_O = 50 \Omega$.

Figure 5. Terminal Enable and Disable Times Load Circuit and Voltage Waveforms

TYPICAL CHARACTERISTICS

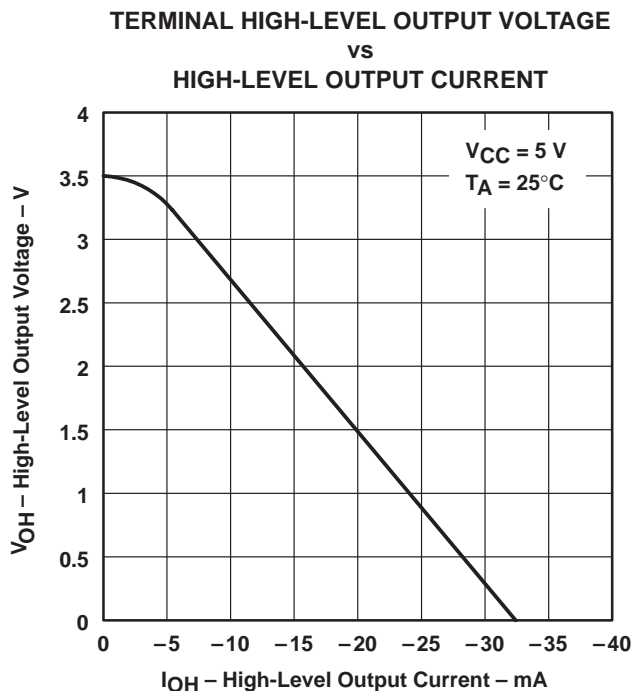

Figure 6

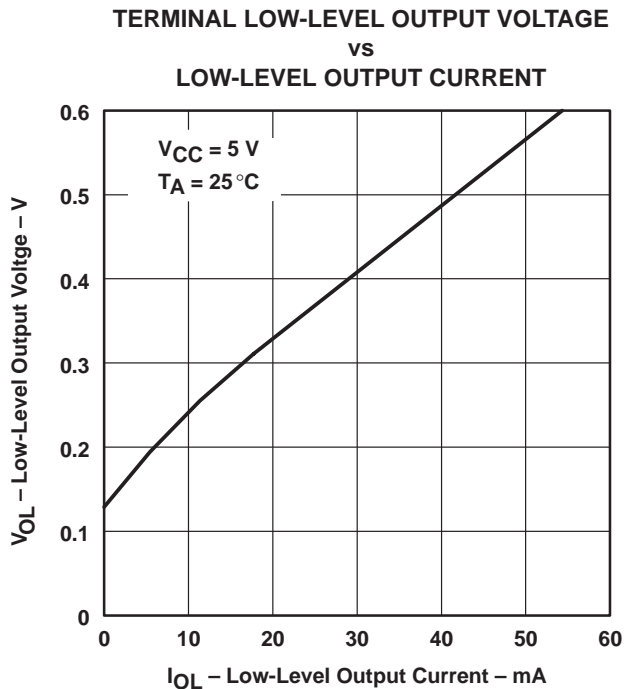

Figure 7

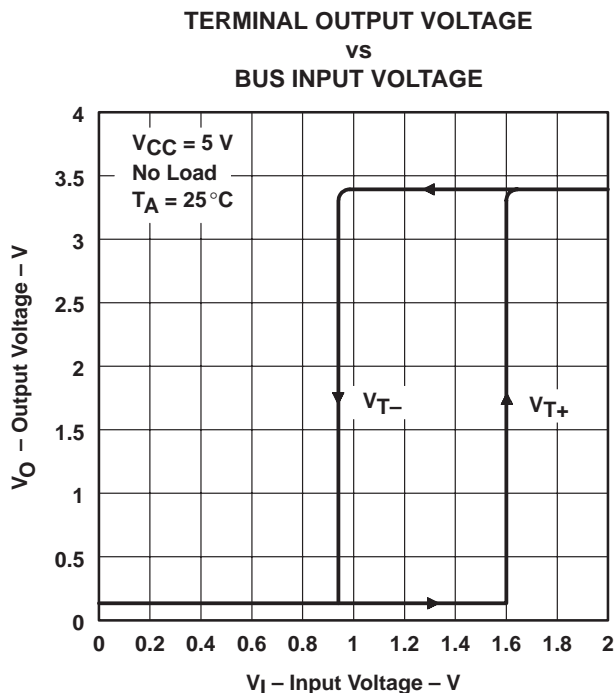
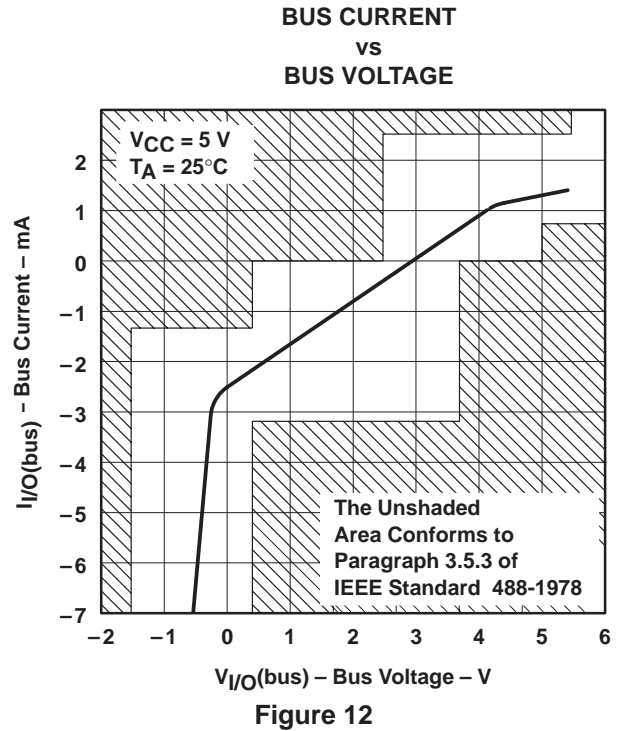
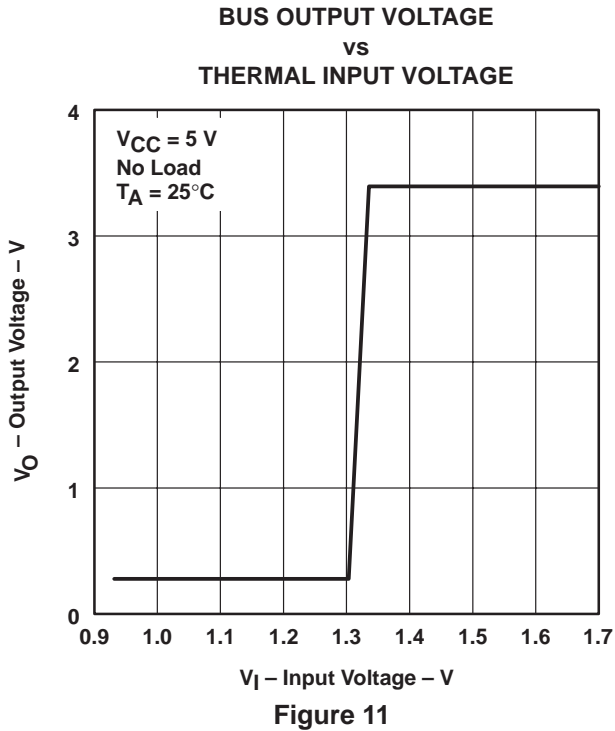
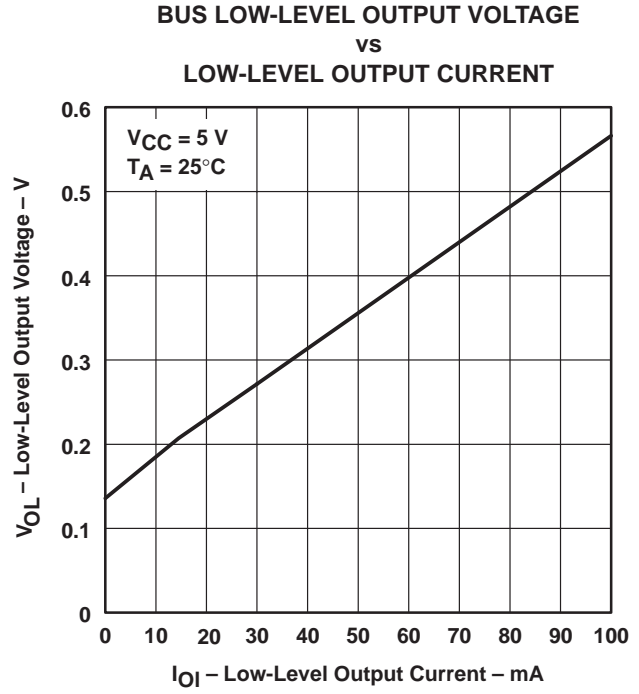
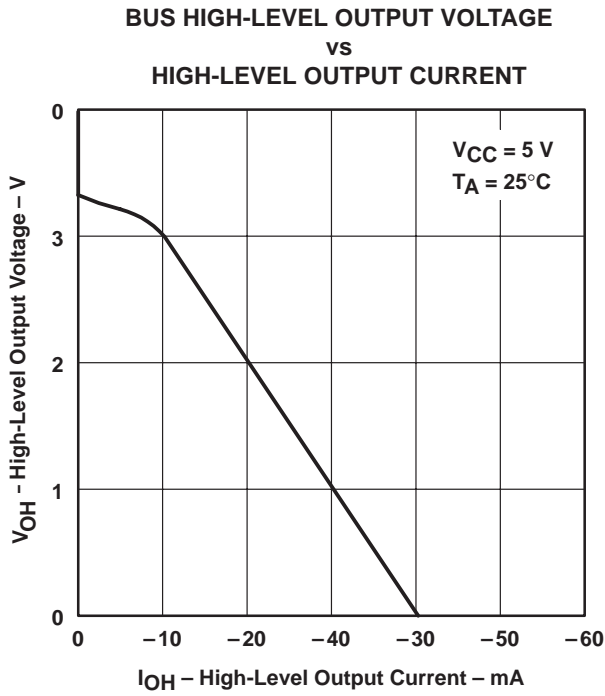

Figure 8

SN75164B OCTAL GENERAL-PURPOSE INTERFACE BUS TRANSCEIVER

SLLS011A – OCTOBER 1985 – REVISED FEBRUARY 1993

TYPICAL CHARACTERISTICS



PACKAGING INFORMATION

Orderable Device	Status ⁽¹⁾	Package Type	Package Drawing	Pins	Package Qty	Eco Plan ⁽²⁾	Lead/Ball Finish	MSL Peak Temp ⁽³⁾
SN75164BN	OBSOLETE	PDIP	N	22		TBD	Call TI	Call TI

⁽¹⁾ The marketing status values are defined as follows:

ACTIVE: Product device recommended for new designs.

LIFEBUY: TI has announced that the device will be discontinued, and a lifetime-buy period is in effect.

NRND: Not recommended for new designs. Device is in production to support existing customers, but TI does not recommend using this part in a new design.

PREVIEW: Device has been announced but is not in production. Samples may or may not be available.

OBSOLETE: TI has discontinued the production of the device.

⁽²⁾ Eco Plan - The planned eco-friendly classification: Pb-Free (RoHS) or Green (RoHS & no Sb/Br) - please check <http://www.ti.com/productcontent> for the latest availability information and additional product content details.

TBD: The Pb-Free/Green conversion plan has not been defined.

Pb-Free (RoHS): TI's terms "Lead-Free" or "Pb-Free" mean semiconductor products that are compatible with the current RoHS requirements for all 6 substances, including the requirement that lead not exceed 0.1% by weight in homogeneous materials. Where designed to be soldered at high temperatures, TI Pb-Free products are suitable for use in specified lead-free processes.

Green (RoHS & no Sb/Br): TI defines "Green" to mean Pb-Free (RoHS compatible), and free of Bromine (Br) and Antimony (Sb) based flame retardants (Br or Sb do not exceed 0.1% by weight in homogeneous material)

⁽³⁾ MSL, Peak Temp. -- The Moisture Sensitivity Level rating according to the JEDEC industry standard classifications, and peak solder temperature.

Important Information and Disclaimer:The information provided on this page represents TI's knowledge and belief as of the date that it is provided. TI bases its knowledge and belief on information provided by third parties, and makes no representation or warranty as to the accuracy of such information. Efforts are underway to better integrate information from third parties. TI has taken and continues to take reasonable steps to provide representative and accurate information but may not have conducted destructive testing or chemical analysis on incoming materials and chemicals. TI and TI suppliers consider certain information to be proprietary, and thus CAS numbers and other limited information may not be available for release.

In no event shall TI's liability arising out of such information exceed the total purchase price of the TI part(s) at issue in this document sold by TI to Customer on an annual basis.

IMPORTANT NOTICE

Texas Instruments Incorporated and its subsidiaries (TI) reserve the right to make corrections, modifications, enhancements, improvements, and other changes to its products and services at any time and to discontinue any product or service without notice. Customers should obtain the latest relevant information before placing orders and should verify that such information is current and complete. All products are sold subject to TI's terms and conditions of sale supplied at the time of order acknowledgment.

TI warrants performance of its hardware products to the specifications applicable at the time of sale in accordance with TI's standard warranty. Testing and other quality control techniques are used to the extent TI deems necessary to support this warranty. Except where mandated by government requirements, testing of all parameters of each product is not necessarily performed.

TI assumes no liability for applications assistance or customer product design. Customers are responsible for their products and applications using TI components. To minimize the risks associated with customer products and applications, customers should provide adequate design and operating safeguards.

TI does not warrant or represent that any license, either express or implied, is granted under any TI patent right, copyright, mask work right, or other TI intellectual property right relating to any combination, machine, or process in which TI products or services are used. Information published by TI regarding third-party products or services does not constitute a license from TI to use such products or services or a warranty or endorsement thereof. Use of such information may require a license from a third party under the patents or other intellectual property of the third party, or a license from TI under the patents or other intellectual property of TI.

Reproduction of information in TI data books or data sheets is permissible only if reproduction is without alteration and is accompanied by all associated warranties, conditions, limitations, and notices. Reproduction of this information with alteration is an unfair and deceptive business practice. TI is not responsible or liable for such altered documentation.

Resale of TI products or services with statements different from or beyond the parameters stated by TI for that product or service voids all express and any implied warranties for the associated TI product or service and is an unfair and deceptive business practice. TI is not responsible or liable for any such statements.

Following are URLs where you can obtain information on other Texas Instruments products and application solutions:

Products		Applications	
Amplifiers	amplifier.ti.com	Audio	www.ti.com/audio
Data Converters	dataconverter.ti.com	Automotive	www.ti.com/automotive
DSP	dsp.ti.com	Broadband	www.ti.com/broadband
Interface	interface.ti.com	Digital Control	www.ti.com/digitalcontrol
Logic	logic.ti.com	Military	www.ti.com/military
Power Mgmt	power.ti.com	Optical Networking	www.ti.com/opticalnetwork
Microcontrollers	microcontroller.ti.com	Security	www.ti.com/security
		Telephony	www.ti.com/telephony
		Video & Imaging	www.ti.com/video
		Wireless	www.ti.com/wireless

Mailing Address: Texas Instruments
Post Office Box 655303 Dallas, Texas 75265