

SN8P2723

USER'S MANUAL

Preliminary Version 0.5

SN8P2723

SONiX 8-Bit Micro-Controller

SONiX reserves the right to make change without further notice to any products herein to improve reliability, function or design. SONiX does not assume any liability arising out of the application or use of any product or circuit described herein; neither does it convey any license under its patent rights nor the rights of others. SONiX products are not designed, intended, or authorized for use as components in systems intended, for surgical implant into the body, or other applications intended to support or sustain life, or for any other application in which the failure of the SONiX product could create a situation where personal injury or death may occur. Should Buyer purchase or use SONiX products for any such unintended or unauthorized application. Buyer shall indemnify and hold SONiX and its officers, employees, subsidiaries, affiliates and distributors harmless against all claims, cost, damages, and expenses, and reasonable attorney fees arising out of, directly or indirectly, any claim of personal injury or death associated with such unintended or unauthorized use even if such claim alleges that SONiX was negligent regarding the design or manufacture of the part.

AMENDENT HISTORY

Version	Date	Description
VER 0.1	Jun. 2013	First issue.
VER 0.2	Jul. 2013	Add development tool section.
VER 0.3	Aug. 2013	Add DIP16/SOP16 package type.
VER 0.4	Aug. 2013	Modify DIP16/SOP16 pin assignment.
VER 0.5	Aug. 2014	1. Modify ADC section and OSCM register section. 2. Add TSSOP20 package type.

Table of Content

AMENDMENT HISTORY	2
1 PRODUCT OVERVIEW	7
1.1 FEATURES	7
1.2 SYSTEM BLOCK DIAGRAM	8
1.3 PIN ASSIGNMENT	9
1.4 PIN DESCRIPTIONS	10
1.5 PIN CIRCUIT DIAGRAMS	11
2 CENTRAL PROCESSOR UNIT (CPU)	12
2.1 PROGRAM MEMORY (ROM)	12
2.1.1 RESET VECTOR (0000H)	13
2.1.2 INTERRUPT VECTOR (0008H).....	13
2.1.3 LOOK-UP TABLE DESCRIPTION	15
2.1.4 JUMP TABLE DESCRIPTION	17
2.1.5 CHECKSUM CALCULATION.....	19
2.2 DATA MEMORY (RAM).....	20
2.2.1 SYSTEM REGISTER	20
2.2.1.1 SYSTEM REGISTER TABLE	20
2.2.1.2 SYSTEM REGISTER DESCRIPTION	20
2.2.1.3 BIT DEFINITION of SYSTEM REGISTER	21
2.2.2 ACCUMULATOR	22
2.2.3 PROGRAM FLAG	23
2.2.4 PROGRAM COUNTER.....	24
2.2.5 H, L REGISTERS.....	27
2.2.6 Y, Z REGISTERS.....	28
2.2.7 R REGISTER	28
2.3 ADDRESSING MODE	29
2.3.1 IMMEDIATE ADDRESSING MODE	29
2.3.2 DIRECTLY ADDRESSING MODE	29
2.3.3 INDIRECTLY ADDRESSING MODE	29
2.4 STACK OPERATION.....	30
2.4.1 OVERVIEW	30
2.4.2 STACK REGISTERS	31
2.4.3 STACK OPERATION EXAMPLE.....	32
2.5 CODE OPTION TABLE	33
2.5.1 Fcpu code option	34
2.5.2 Reset_Pin code option	34
2.5.3 Security code option	34
2.5.4 Noise Filter code option	34
2.5.5 Low_Power code option.....	34
3 RESET	35
3.1 OVERVIEW	35
3.2 POWER ON RESET.....	36
3.3 WATCHDOG RESET	36
3.4 BROWN OUT RESET	36
3.5 THE SYSTEM OPERATING VOLTAGE.....	37
3.6 LOW VOLTAGE DETECTOR (LVD)	37
3.7 BROWN OUT RESET IMPROVEMENT	39
3.8 EXTERNAL RESET	40

3.9	EXTERNAL RESET CIRCUIT	40
3.9.1	Simply RC Reset Circuit	40
3.9.2	Diode & RC Reset Circuit	41
3.9.3	Zener Diode Reset Circuit	41
3.9.4	Voltage Bias Reset Circuit	42
3.9.5	External Reset IC	42
4	SYSTEM CLOCK	43
4.1	OVERVIEW	43
4.2	F _{CPU} (INSTRUCTION CYCLE)	43
4.3	NOISE FILTER	44
4.4	SYSTEM HIGH-SPEED CLOCK	44
4.5	HIGH_CLK CODE OPTION	44
4.5.1	INTERNAL HIGH-SPEED OSCILLATOR RC TYPE (IHRC)	44
4.5.2	EXTERNAL HIGH-SPEED OSCILLATOR	44
4.5.3	EXTERNAL OSCILLATOR APPLICATION CIRCUIT	45
4.6	SYSTEM LOW-SPEED CLOCK	46
4.7	OSCM REGISTER	47
4.8	SYSTEM CLOCK MEASUREMENT	47
4.9	SYSTEM CLOCK TIMING	48
5	SYSTEM OPERATION MODE	51
5.1	OVERVIEW	51
5.2	NORMAL MODE	52
5.3	SLOW MODE	52
5.4	POWER DOWN MDOE	53
5.5	GREEN MODE	53
5.6	OPERATING MODE CONTROL MACRO	54
5.7	WAKEUP	55
5.7.1	OVERVIEW	55
5.7.2	WAKEUP TIME	55
5.7.3	P1W WAKEUP CONTROL REGISTER	55
6	INTERRUPT	56
6.1	OVERVIEW	56
6.2	INTEN INTERRUPT ENABLE REGISTER	57
6.3	INTRQ INTERRUPT REQUEST REGISTER	58
6.4	GIE GLOBAL INTERRUPT OPERATION	59
6.5	EXTERNAL INTERRUPT OPERATION (INT0~INT2)	60
6.6	T0 INTERRUPT OPERATION	62
6.7	TC0 INTERRUPT OPERATION	63
6.8	TC1 INTERRUPT OPERATION	64
6.9	TC2 INTERRUPT OPERATION	65
6.10	TC3 INTERRUPT OPERATION	66
6.11	MULTI-INTERRUPT OPERATION	67
7	I/O PORT	69
7.1	OVERVIEW	69
7.2	I/O PORT MODE	70
7.3	I/O PULL UP REGISTER	71
7.4	I/O PULL DOWN REGISTER	72
7.5	PORT1 I/O SCHMITT-TRIGGER REGISTER	73
7.6	I/O PORT DATA REGISTER	74
8	TIMERS	75
8.1	WATCHDOG TIMER	75
8.2	T0 8-BIT BASIC TIMER	77

8.2.1	OVERVIEW	77
8.2.2	T0 Timer Operation	78
8.2.3	T0M MODE REGISTER	79
8.2.4	T0C COUNTING REGISTER	79
8.2.5	T0 TIMER OPERATION EXPLAME	80
8.3	TC0 8-BIT TIMER/COUNTER	81
8.3.1	OVERVIEW	81
8.3.2	TC0 TIMER OPERATION	82
8.3.3	TC0M MODE REGISTER.....	83
8.3.4	TC0C COUNTING REGISTER	83
8.3.5	TC0R AUTO-RELOAD REGISTER.....	84
8.3.6	TC0D PWM DUTY REGISTER	84
8.3.7	TC0 EVENT COUNTER	85
8.3.8	PULSE WIDTH MODULATION (PWM)	85
8.3.9	One Pulse PWM	87
8.3.10	TC0 TIMER OPERATION EXAMPLE	87
8.4	TC1 8-BIT TIMER/COUNTER	89
8.4.1	OVERVIEW	89
8.4.2	TC1 TIMER OPERATION	90
8.4.3	TC1M MODE REGISTER.....	91
8.4.4	TC1C COUNTING REGISTER	91
8.4.5	TC1R AUTO-RELOAD REGISTER.....	92
8.4.6	TC1D PWM DUTY REGISTER	92
8.4.7	PULSE WIDTH MODULATION (PWM)	93
8.4.8	2-Channel PWM.....	94
8.4.9	One Pulse PWM	95
8.4.10	PWM output with Extension function	95
8.4.11	TC1 TIMER OPERATION EXAMPLE	97
TC2 8-BIT TIMER/COUNTER		99
8.4.12	OVERVIEW	99
8.4.13	TC2 TIMER OPERATION	100
8.4.14	TC2M MODE REGISTER.....	101
8.4.15	TC2C COUNTING REGISTER	101
8.4.16	TC2R AUTO-RELOAD REGISTER.....	102
8.4.17	TC2D PWM DUTY REGISTER	102
8.4.18	PULSE WIDTH MODULATION (PWM)	103
8.4.19	2-Channel PWM.....	104
8.4.20	One Pulse PWM	105
8.4.21	PWM output with Extension function	105
8.4.22	TC2 TIMER OPERATION EXAMPLE	107
8.5	TC3 8-BIT TIMER/COUNTER	109
8.5.1	OVERVIEW	109
8.5.2	TC3 TIMER OPERATION	110
8.5.3	TC3M MODE REGISTER.....	111
8.5.4	TC3C COUNTING REGISTER	111
8.5.5	TC3R AUTO-RELOAD REGISTER.....	112
8.5.6	TC3D PWM DUTY REGISTER	112
8.5.7	PULSE WIDTH MODULATION (PWM)	113
8.5.8	2-Channel PWM.....	114
8.5.9	One Pulse PWM	115
8.5.10	PWM output with Extension function	115
8.5.11	TC3 TIMER OPERATION EXAMPLE	117

9	12 CHANNEL ANALOG TO DIGITAL CONVERTER (ADC)	119
9.1	OVERVIEW	119
9.2	ADC MODE REGISTER	120
9.3	ADC DATA BUFFER REGISTERS	121
9.4	ADC REFERENCE VOLTQAGE REGISTERS	122
9.5	ADC OPERATION DESCRIPTION AND NOTIC	122
9.5.1	ADC SIGNAL FORMAT	122
9.5.2	ADC CONVERTING TIME	123
9.5.3	ADC PIN CONFIGURATION	124
9.6	ADC OPERATION EXAMLPE.....	125
9.7	ADC APPLICATION CIRCUIT	128
10	INSTRUCTION TABLE	129
11	ELECTRICAL CHARACTERISTIC	130
11.1	ABSOLUTE MAXIMUM RATING	130
11.2	ELECTRICAL CHARACTERISTIC	130
11.3	CHARACTERISTIC GRAPHS	132
12	DEVELOPMENT TOOL	133
12.1	SN8P2723 EV-KIT	133
12.2	ICE AND EV-KIT APPLICATION NOTIC	134
13	OTP PROGRAMMING PIN	135
13.1	WRITER TRANSITION BOARD SOCKET PIN ASSIGNMENT	135
13.2	PROGRAMMING PIN MAPPING:.....	136
14	MARKING DEFINITION	137
14.1	INTRODUCTION	137
14.2	MARKING INDETIFICATION SYSTEM.....	137
14.3	MARKING EXAMPLE	137
14.4	DATECODE SYSTEM	138
15	PACKAGE INFORMATION	139
15.1	P-DIP 20 PIN	139
15.2	SOP 20 PIN	140
15.3	SSOP 20 PIN.....	141
15.4	TSSOP 20 PIN	142
15.5	P-DIP 16 PIN	143
15.6	SOP 16 PIN.....	144
15.7	P-DIP 14 PIN	145
15.8	SOP 14 PIN.....	146

1 PRODUCT OVERVIEW

1.1 FEATURES

- ◆ **Memory configuration**
ROM size: 2K * 16 bits.
RAM size: 128 * 8 bits.
- ◆ **8 levels stack buffer.**
- ◆ **9 interrupt sources**
6 internal interrupts: T0, TC0, TC1, TC2, TC3, ADC
3 external interrupt: INT0, INT1, INT2
- ◆ **I/O pin configuration**
Bi-directional: P1, P2, P4.
Wakeup: P1 level change.
Pull-up resistors: P1, P2, P4.
Pull-down resistors: P1.3~P1.6.
20mA Sink/Drive: P1, P2, P4
External interrupt: P4.0, P4.1, P4.2.
Reset/Open-Drain: P1.2
ADC input pin: AIN0~AIN11.
External Interrupt trigger edge:
P4.0~P4.2 controlled by PEDGE register.
- ◆ **Fcpu (Instruction cycle)**
 $F_{cpu} = F_{osc}/1, F_{osc}/2, F_{osc}/4, F_{osc}/8, F_{osc}/16, F_{osc}/32, F_{osc}/64, F_{osc}/128.$
- ◆ **3-Level LVD**
2.1V/2.4V/3.6V
- ◆ **Powerful instructions**
Instruction's length is one word.
Most of instructions are one cycle only.
All ROM area JMP/CALL instruction.
All ROM area look-up table function (MOVC).
- ◆ **Five 8-bit timers. (T0, TC0, TC1, TC2, TC3).**
T0: Basic timer with 0.5sec RTC.
TC0: Timer/PWM/Pulse/Counter.
TC1: Timer/PWM/Pulse/Extension.
TC2: Timer/PWM/Pulse/Extension.
TC3: Timer/PWM/Pulse/Extension.
- ◆ **6-channel duty/cycle programmable PWMs with extension, from a generator to output PWM, Buzzer, IR carrier and single pulse.**
- ◆ **12+1 channel 12-bit SAR ADC with 3-level Int. Ref.**
Twelve external ADC input
One internal battery measurement
Internal AD reference voltage (VDD, 3.5V, 2.5V).
- ◆ **On chip watchdog timer and clock source is Internal low clock RC type (16KHz @3V, 32KHz @5V).**
- ◆ **Four system clocks.**
External high clock: RC type up to 10MHz
External high clock: Crystal type up to 16MHz
Internal high clock: RC type (IHRC) 16MHz
Internal low clock: RC type 16KHz(3V), 32KHz(5V)
- ◆ **Four operating modes**
Normal mode: Both high and low clock active
Slow mode: Low clock only.
Sleep mode: Both high and low clock stop
Green mode: Periodical wakeup by timer
- ◆ **Package (Chip form support)**
PDIP 20 pin
SOP 20 pin
SSOP 20 pin
TSSOP 20 pin
PDIP 16 pin
SOP 16 pin
PDIP 14 pin
SOP 14 pin

● **Features Selection Table**

CHIP	ROM	RAM	Stack	Timer			I/O	Pull-down	20mA IoH/ IoL	ADC CH.	PWM	Interrupt Ext/Int	Wake-up Pin No.	Package
				T0	TC0	TC1-TC3								
SN8P2723	2K	128	8	V	V	V	18	4	17/18	12+1	7	3/6	8	PDIP20 SOP20 SSOP20 TSSOP20
SN8P27231	2K	128	8	V	V	V	12	2	11/12	7+1	3	2/6	5	PDIP14 SOP14
SN8P27232	2K	128	8	V	V	V	14	2	13/14	9+1	5	2/6	5	PDIP16 SOP16
SN8P2722	2K	128	8	V	V	-	18	-	-	5	2	1/3	8	PDIP20 SOP20 SSOP20 TSSOP20
SN8P2712	2K	96	8	V	V	-	16	-	-	12	4	1/2	8	PDIP18 SOP18 SSOP20 TSSOP20

1.2 SYSTEM BLOCK DIAGRAM

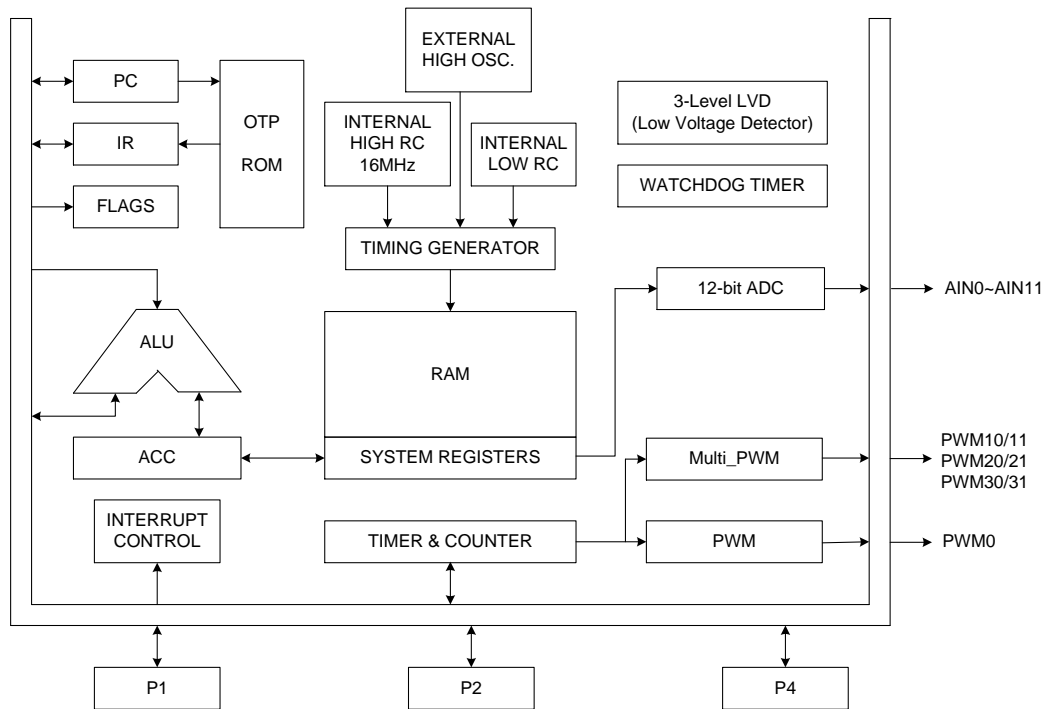

1.3 PIN ASSIGNMENT

SN8P2723P (PDIP 20 pins)
SN8P2723S (SOP 20 pins)
SN8P2723X (SSOP 20 pins)
SN8P2723T (TSSOP 20 pins)

Vss	1	U	20	Vdd
XIN/P1.0	2		19	P4.0/AIN0/INT0/AVREFH/TC0
XOUT/P1.1	3		18	P4.1/AIN1/INT1
RST/P1.2	4		17	P4.2/AIN2/INT2
PWM11/P1.3	5		16	P4.3/AIN3
PWM21/P1.4	6		15	P4.4/AIN4
PWM31/P1.5	7		14	P4.5/AIN5
AIN11/P1.6	8		13	P4.6/AIN6/PWM0
PWM10/AIN10/P1.7	9		12	P4.7/AIN7
PWM20/AIN9/P2.0	10		11	P2.1/AIN8/PWM30

SN8P27232P (PDIP 16 pins)
SN8P27232S (SOP 16 pins)

Vdd	1	U	16	Vss
XIN/P1.0	2		15	P4.0/AIN0/INT0/AVREFH/TC0
XOUT/P1.1	3		14	P4.1/AIN1/INT1
RST/P1.2	4		13	P4.3/AIN3
PWM11/P1.3	5		12	P4.4/AIN4
PWM21/P1.4	6		11	P4.5/AIN5
PWM20/AIN9/P2.0	7		10	P4.6/AIN6/PWM0
PWM30/AIN8/P2.1	8		9	P4.7/AIN7

SN8P27231P (PDIP 14 pins)
SN8P27231S (SOP 14 pins)

Vdd	1	U	14	Vss
XIN/P1.0	2		13	P4.0/AIN0/INT0/AVREFH/TC0
XOUT/P1.1	3		12	P4.1/AIN1/INT1
RST/P1.2	4		11	P4.3/AIN3
PWM11/P1.3	5		10	P4.4/AIN4
PWM21/P1.4	6		9	P4.5/AIN5
P4.7/AIN7	7		8	P4.6/AIN6/PWM0

1.4 PIN DESCRIPTIONS

PIN NAME	TYPE	DESCRIPTION
VDD, VSS	P	Power supply input pins for digital and analog circuit.
P1.2/RST/VPP	I, P	RST: System external reset input pin. Schmitt trigger structure, active "low", normal stay to "high".
		VPP: OTP 12.3V power input pin in programming mode.
XIN/P1.0	I/O	P1.2: Bi-direction pin. Schmitt trigger structure as input mode and no pull-up/pull-down resistors. Build in wake-up function. Open-drain structure as output mode.
		XIN: Oscillator input pin while external oscillator enable (crystal and RC).
XOUT/P1.1	I/O	P1.0: Bi-direction pin. Schmitt trigger structure as input mode. Built-in pull-up resistor. Build in wake-up function.
		XOUT: Oscillator output pin while external crystal enable.
P4.0/INT0/TC0/ AIN0/AVREFH	I/O	P1.1: Bi-direction pin. Schmitt trigger structure as input mode. Built-in pull-up resistor. Build in wake-up function.
		P4.0: Bi-direction pin. Schmitt trigger structure as input mode. Built-in pull-up resistor.
		INT0: External interrupt 0 input pin.
		TC0: TC0 event counter input pin.
P4.1/INT1/AIN1	I/O	AIN0: ADC channel 0 input pin.
		AVREFH: ADC external high reference voltage input.
P4.2/INT2/AIN2	I/O	P4.1: Bi-direction pin. Schmitt trigger structure as input mode. Built-in pull-up resistor.
		INT1: External interrupt 1 input pin.
P4.3/AIN3	I/O	AIN1: ADC channel 1 input pin.
		P4.2: Bi-direction pin. Schmitt trigger structure as input mode. Built-in pull-up resistor.
P4.4/AIN4	I/O	INT2: External interrupt 2 input pin.
		AIN2: ADC channel 2 input pin.
P4.5/AIN5	I/O	P4.3: Bi-direction pin. Schmitt trigger structure as input mode. Built-in pull-up resistor.
		AIN3: ADC channel 3 input pin.
P4.6/AIN6/PWM0	I/O	P4.4: Bi-direction pin. Schmitt trigger structure as input mode. Built-in pull-up resistor.
		AIN4: ADC channel 4 input pin.
P4.7/AIN7	I/O	P4.5: Bi-direction pin. Schmitt trigger structure as input mode. Built-in pull-up resistor.
		AIN5: ADC channel 5 input pin.
P1.3/PWM11	I/O	P4.6: Bi-direction pin. Schmitt trigger structure as input mode. Built-in pull-up resistors.
		PWM0: TC0 programmable PWM0 output pin.
P1.4/PWM21	I/O	AIN6: ADC channel 6 input pin.
		P4.7: Bi-direction pin. Schmitt trigger structure as input mode. Built-in pull-up resistors.
P1.5/PWM31	I/O	AIN7: ADC channel 7 input pin.
		P1.3: Bi-direction pin. Schmitt trigger structure as input mode. Built-in pull-up/pull-down resistors. Build in wake-up function.
P1.6/AIN8	I/O	PWM11: TC1 programmable PWM output pin.
		P1.4: Bi-direction pin. Schmitt trigger structure as input mode. Built-in pull-up/pull-down resistors. Build in wake-up function.
P1.7/AIN9/ PWM10	I/O	PWM21: TC2 programmable PWM output pin.
		P1.5: Bi-direction pin. Schmitt trigger structure as input mode. Built-in pull-up/pull-down resistors. Build in wake-up function.
P2.0/PWM20/ AIN10	I/O	PWM31: TC3 programmable PWM output pin.
		P1.6: Bi-direction pin. Schmitt trigger structure as input mode. Built-in pull-up/pull-down resistors. Build in wake-up function.
P2.1/AIN11/ PWM30	I/O	AIN8: ADC channel 8 input pin.
		P1.7: Bi-direction pin. Schmitt trigger structure as input mode. Built-in pull-up resistors. Build in wake-up function.
		AIN9: ADC channel 9 input pin.
		PWM10: TC1 programmable PWM output pin.
		P2.0: Bi-direction pin. Schmitt trigger structure as input mode. Built-in pull-up resistors.
		AIN10: ADC channel 10 input pin.
		PWM20: TC2 programmable PWM output pin.
		P2.1: Bi-direction pin. Schmitt trigger structure as input mode. Built-in pull-up resistors.
		AIN11: ADC channel 11 input pin.
		PWM30: TC3 programmable PWM output pin.

1.5 PIN CIRCUIT DIAGRAMS

- **Reset shared pin structure:**

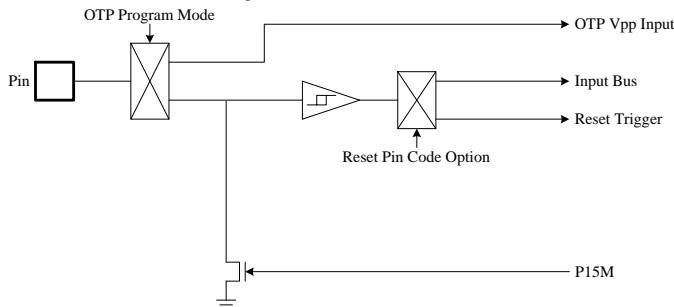

- **Normal bi-direction pin structure:**

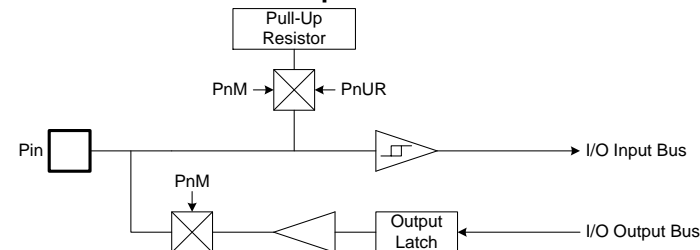

- **Bi-direction shared pin structure with specific analog input function (e.g. Xin, Xout):**

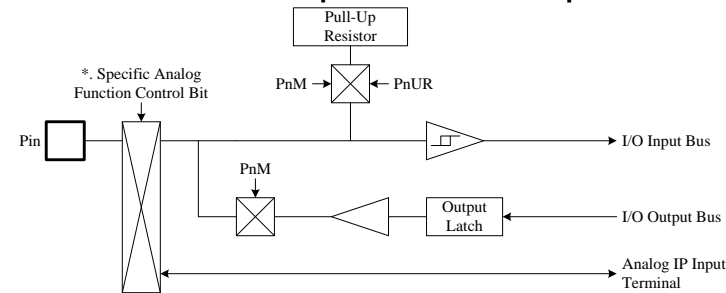

*. Some specific functions switch I/O direction directly, not through PnM register.

- **Bi-direction shared pin structure with pull-up/pull-down resistor:**

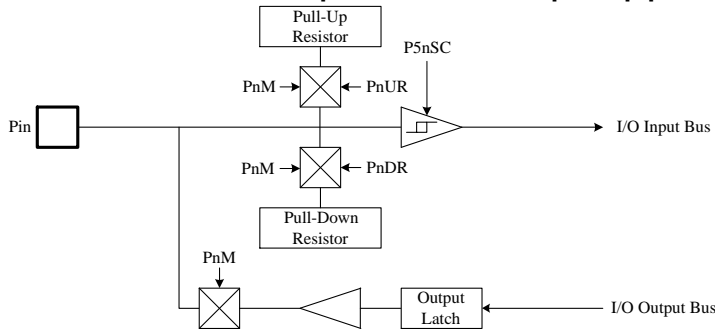

- **Bi-direction shared pin structure with specific digital output function (e.g. PWM, Buzzer,):**

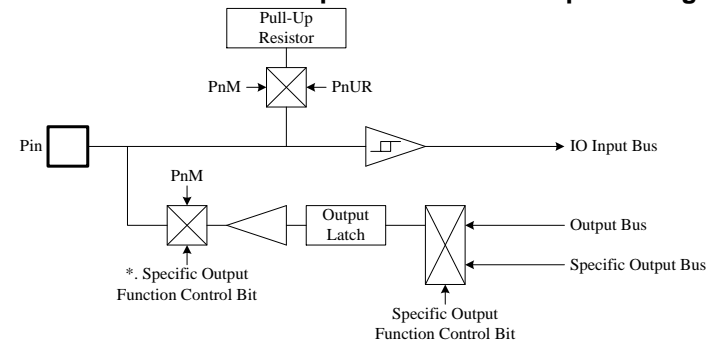

*. Some specific functions switch I/O direction directly, not through PnM register.

2 CENTRAL PROCESSOR UNIT (CPU)

2.1 PROGRAM MEMORY (ROM)

☞ 2K words ROM

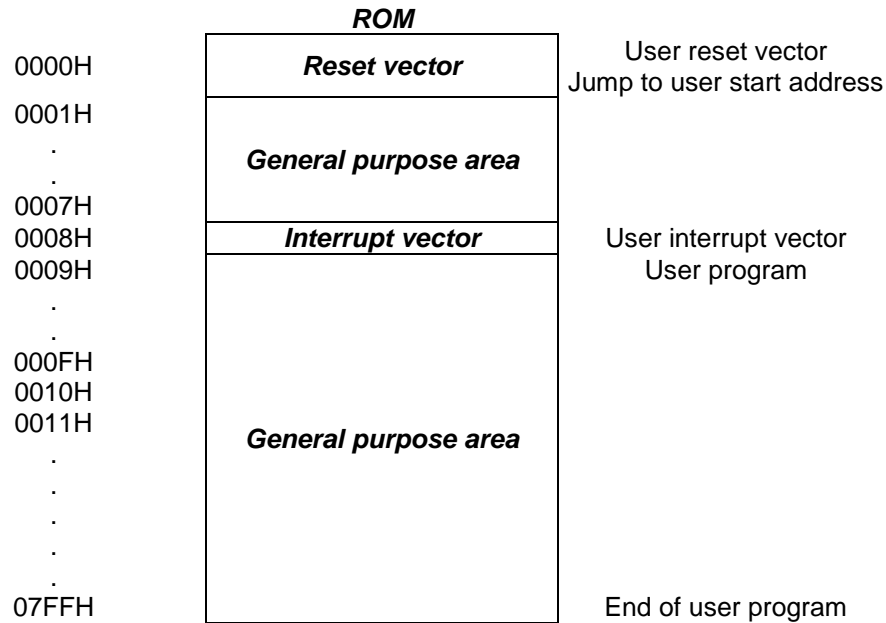

The ROM includes Reset vector, Interrupt vector, General purpose area and reserved area. The Reset vector is program beginning address. The Interrupt vector is the head of interrupt service routine when any interrupt occurring. The General purpose area is main program area including main loop, sub-routines and data table.

2.1.1 RESET VECTOR (0000H)

A one-word vector address area is used to execute system reset.

- ☞ **Power On Reset (NT0=1, NPD=0).**
- ☞ **Watchdog Reset (NT0=0, NPD=0).**
- ☞ **External Reset (NT0=1, NPD=1).**

After power on reset, external reset or watchdog timer overflow reset, then the chip will restart the program from address 0000h and all system registers will be set as default values. It is easy to know reset status from NT0, NPD flags of PFLAG register. The following example shows the way to define the reset vector in the program memory.

➤ Example: Defining Reset Vector

```

                ORG      0          ; 0000H
                JMP      START     ; Jump to user program address.
                ...

START:         ORG      10H        ; 0010H, The head of user program.
                ...              ; User program
                ...

                ENDP           ; End of program

```

2.1.2 INTERRUPT VECTOR (0008H)

A 1-word vector address area is used to execute interrupt request. If any interrupt service executes, the program counter (PC) value is stored in stack buffer and jump to 0008h of program memory to execute the vectored interrupt. Users have to define the interrupt vector. The following example shows the way to define the interrupt vector in the program memory.

* **Note: The “PUSH” and “POP” operations aren’t through instruction (PUSH, POP) and can executed save and load ACC and PFLAG without NT0/NPD by hardware automatically.**

➤ Example: Defining Interrupt Vector. The interrupt service routine is following ORG 8.

```

.CODE
                ORG      0          ; 0000H
                JMP      START     ; Jump to user program address.
                ...

                ORG      8          ; Interrupt vector.
                ...              ; Save ACC and PFLAG register to buffers.
                ...
                ...
                ...              ; Load ACC and PFLAG register from buffers.
                RETI           ; End of interrupt service routine
                ...

START:         ; The head of user program.
                ...              ; User program
                ...
                JMP      START     ; End of user program
                ...

```

ENDP ; End of program

➤ **Example: Defining Interrupt Vector. The interrupt service routine is following user program.**

```
.CODE
    ORG     0           ; 0000H
    JMP     START      ; Jump to user program address.
    ...
    ORG     8           ; Interrupt vector.
                       ; Save ACC and PFLAG register to buffers.
    JMP     MY_IRQ     ; 0008H, Jump to interrupt service routine address.

START:
    ORG     10H        ; 0010H, The head of user program.
    ...               ; User program.
    ...
    JMP     START      ; End of user program.
    ...

MY_IRQ:
    ...               ; The head of interrupt service routine.

    ...
    RETI      ; End of interrupt service routine.
    ...       ; Load ACC and PFLAG register from buffers.

    ENDP      ; End of program.
```

- * **Note:** It is easy to understand the rules of SONiX program from demo programs given above. These points are as following:
1. The address 0000H is a "JMP" instruction to make the program starts from the beginning.
 2. The address 0008H is interrupt vector.
 3. User's program is a loop routine for main purpose application.

2.1.3 LOOK-UP TABLE DESCRIPTION

In the ROM's data lookup function, Y register is pointed to middle byte address (bit 8~bit 15) and Z register is pointed to low byte address (bit 0~bit 7) of ROM. After MOVC instruction executed, the low-byte data will be stored in ACC and high-byte data stored in R register.

➤ **Example: To look up the ROM data located "TABLE1".**

```

B0MOV      Y, #TABLE1$M      ; To set lookup table1's middle address
B0MOV      Z, #TABLE1$L      ; To set lookup table1's low address.
MOVC                               ; To lookup data, R = 00H, ACC = 35H

                               ; Increment the index address for next address.
INCMS      Z                  ; Z+1
JMP        @F                 ; Z is not overflow.
INCMS      Y                  ; Z overflow (FFH → 00), → Y=Y+1
NOP

@@:        MOVC                               ; To lookup data, R = 51H, ACC = 05H.
...
TABLE1:    DW      0035H      ; To define a word (16 bits) data.
           DW      5105H
           DW      2012H
           ...

```

* **Note:** The Y register will not increase automatically when Z register crosses boundary from 0xFF to 0x00. Therefore, user must be take care such situation to avoid look-up table errors. If Z register is overflow, Y register must be added one. The following INC_YZ macro shows a simple method to process Y and Z registers automatically.

➤ **Example: INC_YZ macro.**

```

INC_YZ      MACRO
           INCMS      Z          ; Z+1
           JMP        @F        ; Not overflow

           INCMS      Y          ; Y+1
           NOP          ; Not overflow

@@:
           ENDM

```

➤ **Example: Modify above example by “INC_YZ” macro.**

```

B0MOV    Y, #TABLE1$M    ; To set lookup table1's middle address
B0MOV    Z, #TABLE1$L    ; To set lookup table1's low address.
MOVC                                          ; To lookup data, R = 00H, ACC = 35H

    INC_YZ                ; Increment the index address for next address.
    ;
@@:      MOVC              ; To lookup data, R = 51H, ACC = 05H.
    ...
TABLE1:  DW                ; To define a word (16 bits) data.
         DW    0035H
         DW    5105H
         DW    2012H
    ...

```

The other example of look-up table is to add Y or Z index register by accumulator. Please be careful if “carry” happen.

➤ **Example: Increase Y and Z register by B0ADD/ADD instruction.**

```

B0MOV    Y, #TABLE1$M    ; To set lookup table's middle address.
B0MOV    Z, #TABLE1$L    ; To set lookup table's low address.

    B0MOV    A, BUF      ; Z = Z + BUF.
    B0ADD    Z, A

    B0BTS1   FC        ; Check the carry flag.
    JMP      GETDATA   ; FC = 0
    INCMS   Y          ; FC = 1. Y+1.
    NOP

GETDATA:                                          ;
    MOVC                                          ; To lookup data. If BUF = 0, data is 0x0035
    ; If BUF = 1, data is 0x5105
    ; If BUF = 2, data is 0x2012
    ...

TABLE1:  DW                ; To define a word (16 bits) data.
         DW    0035H
         DW    5105H
         DW    2012H
    ...

```

2.1.4 JUMP TABLE DESCRIPTION

The jump table operation is one of multi-address jumping function. Add low-byte program counter (PCL) and ACC value to get one new PCL. If PCL is overflow after PCL+ACC, PCH adds one automatically. The new program counter (PC) points to a series jump instructions as a listing table. It is easy to make a multi-jump program depends on the value of the accumulator (A).

* **Note:** PCH only support PC up counting result and doesn't support PC down counting. When PCL is carry after PCL+ACC, PCH adds one automatically. If PCL borrow after PCL-ACC, PCH keeps value and not change.

➤ **Example: Jump table.**

```

ORG      0X0100      ; The jump table is from the head of the ROM boundary

B0ADD    PCL, A      ; PCL = PCL + ACC, PCH + 1 when PCL overflow occurs.
JMP      A0POINT    ; ACC = 0, jump to A0POINT
JMP      A1POINT    ; ACC = 1, jump to A1POINT
JMP      A2POINT    ; ACC = 2, jump to A2POINT
JMP      A3POINT    ; ACC = 3, jump to A3POINT

```

SONiX provides a macro for safe jump table function. This macro will check the ROM boundary and move the jump table to the right position automatically. The side effect of this macro maybe wastes some ROM size.

➤ **Example: If “jump table” crosses over ROM boundary will cause errors.**

```

@JMP_A    MACRO      VAL
IF        (($+1) !& 0XFF00) != (($+(VAL)) !& 0XFF00)
JMP       ($ | 0XFF)
ORG       ($ | 0XFF)
ENDIF
B0ADD     PCL, A
ENDM

```

* **Note:** “VAL” is the number of the jump table listing number.

➤ **Example: “@JMP_A” application in SONiX macro file called “MACRO3.H”.**

```

B0MOV     A, BUF0    ; “BUF0” is from 0 to 4.
@JMP_A    5          ; The number of the jump table listing is five.
JMP      A0POINT    ; ACC = 0, jump to A0POINT
JMP      A1POINT    ; ACC = 1, jump to A1POINT
JMP      A2POINT    ; ACC = 2, jump to A2POINT
JMP      A3POINT    ; ACC = 3, jump to A3POINT
JMP      A4POINT    ; ACC = 4, jump to A4POINT

```

If the jump table position is across a ROM boundary (0x00FF~0x0100), the “@JMP_A” macro will adjust the jump table routine begin from next RAM boundary (0x0100).

➤ **Example: “@JMP_A” operation.**

; Before compiling program.

ROM address	B0MOV	A, BUF0	; “BUF0” is from 0 to 4.
	@JMP_A	5	; The number of the jump table listing is five.
0X00FD	JMP	A0POINT	; ACC = 0, jump to A0POINT
0X00FE	JMP	A1POINT	; ACC = 1, jump to A1POINT
0X00FF	JMP	A2POINT	; ACC = 2, jump to A2POINT
0X0100	JMP	A3POINT	; ACC = 3, jump to A3POINT
0X0101	JMP	A4POINT	; ACC = 4, jump to A4POINT

; After compiling program.

ROM address	B0MOV	A, BUF0	; “BUF0” is from 0 to 4.
	@JMP_A	5	; The number of the jump table listing is five.
0X0100	JMP	A0POINT	; ACC = 0, jump to A0POINT
0X0101	JMP	A1POINT	; ACC = 1, jump to A1POINT
0X0102	JMP	A2POINT	; ACC = 2, jump to A2POINT
0X0103	JMP	A3POINT	; ACC = 3, jump to A3POINT
0X0104	JMP	A4POINT	; ACC = 4, jump to A4POINT

2.1.5 CHECKSUM CALCULATION

The last ROM address is reserved area. User should avoid these addresses (last address) when calculate the Checksum value.

➤ **Example: The demo program shows how to calculated Checksum from 00H to the end of user's code.**

```

MOV      A,#END_USER_CODE$L
B0MOV   END_ADDR1, A      ; Save low end address to end_addr1
MOV      A,#END_USER_CODE$M
B0MOV   END_ADDR2, A      ; Save middle end address to end_addr2
CLR     Y                  ; Set Y to 00H
CLR     Z                  ; Set Z to 00H

@@:
MOV     MOV     FC          ; Clear C flag
B0BSET  DATA1, A         ; Add A to Data1
ADD     A, R
MOV     DATA2, A         ; Add R to Data2
ADC     END_CHECK        ; Check if the YZ address = the end of code
JMP

AAA:
INCMS   Z                ; Z=Z+1
JMP     @B                ; If Z != 00H calculate to next address
JMP     Y_ADD_1          ; If Z = 00H increase Y

END_CHECK:
MOV     A, END_ADDR1
CMPRS  A, Z              ; Check if Z = low end address
JMP     AAA              ; If Not jump to checksum calculate
MOV     A, END_ADDR2
CMPRS  A, Y              ; If Yes, check if Y = middle end address
JMP     AAA              ; If Not jump to checksum calculate
JMP     CHECKSUM_END     ; If Yes checksum calculated is done.

Y_ADD_1:
INCMS   Y                ; Increase Y
NOP
JMP     @B                ; Jump to checksum calculate

CHECKSUM_END:
...
...
END_USER_CODE:          ; Label of program end

```

2.2 DATA MEMORY (RAM)

☞ 128 X 8-bit RAM

		Address	RAM Location	
BANK 0		000h	General Purpose Area	RAM Bank 0
		"		
		"		
		"		
		07Fh		
		080h		
		"	System Register	080h~0FFh of Bank 0 store system registers.
		"		
		"		
		0FFh		

The 128-byte general purpose RAM is separated into Bank 0. Sonix provides "Bank 0" type instructions (e.g. b0mov, b0add, b0bts1, b0bset...) to control Bank 0 RAM directly.

2.2.1 SYSTEM REGISTER

2.2.1.1 SYSTEM REGISTER TABLE

	0	1	2	3	4	5	6	7	8	9	A	B	C	D	E	F
8	L	H	R	Z	Y		PFLAG									
9																
A	TC1M	TC1C	TC1R	TC1D	TC2M	TC2C	TC2R	TC2D	TC3M	TC3C	TC3R	TC3D	PWCH		P4CON	P1CON
B	VREFH	ADM	ADB	ADR	ADT											PEDGE
C	P1W	P1M	P2M		P4M		INTRQ1	INTEN1	INTRQ0	INTEN0	OSCM	-	WDTR		PCL	PCH
D		P1	P2		P4		P1DR		T0M	T0C	TC0M	TC0C	TC0R	TC0D	PWES	STKP
E		P1UR	P2UR		P4UR		@HL	@YZ								
F	STK7L	STK7H	STK6L	STK6H	STK5L	STK5H	STK4L	STK4H	STK3L	STK3H	STK2L	STK2H	STK1L	STK1H	STK0L	STK0H

2.2.1.2 SYSTEM REGISTER DESCRIPTION

R = Working register and ROM look-up data buffer.
PFLAG = Special flag register.
INTRQ0,1 = Interrupt request register.
WDTR = Watchdog timer clear register.
PnM = Port n input/output mode register.
PnUR = Port n pull-up resistor control register.
PCH, PCL = Program counter.
T0C = T0 counting register.
TC0C = TC0 counting register.
TC0D = TC0 duty control register.
TC1C = TC1 counting register.
TC1D = TC1 duty control register.
STKP = Stack pointer buffer.
TC3M = TC3 mode register.
TC3R = TC3 auto-reload data buffer.
TC3C = TC3 counting register.
TC3D = TC3 duty control register.
PWCH = PWM output channel control register.
STK0~STK7 = Stack 0 ~ stack 7 buffer.
VREFH = ADC reference voltage control register.
ADM = ADC mode register.
ADR = ADC resolution select register.
ADT = ADC offset calibration register.

Y, Z = Working, @YZ and ROM addressing register.
H, L = Working, @HL addressing register.
PEDGE = P4.0~P4.2 edge direction register.
INTEN0,1 = Interrupt enable register.
Pn = Port n data buffer.
OSCM = Oscillator mode register.
P1W = P1 wake-up control register.
P1DR = Port1 pull-down resistor/Schmitt-trigger control register.
PWES = PWM extension control register.
T0M = T0 mode register.
TC0M = TC0 mode register.
TC0R = TC0 auto-reload data buffer.
TC1M = TC1 mode register.
TC1R = TC1 auto-reload data buffer.
TC2M = TC2 mode register.
TC2R = TC2 auto-reload data buffer.
TC2C = TC2 counting register.
TC2D = TC2 duty control register.
P1CON, P4CON = P1, P4 configuration register.
@YZ = RAM YZ indirect addressing index pointer.
@HL = RAM HL indirect addressing index pointer.
ADB = ADC data buffer.

2.2.1.3 BIT DEFINITION of SYSTEM REGISTER

Address	Bit7	Bit6	Bit5	Bit4	Bit3	Bit2	Bit1	Bit0	R/W	Remarks
080H	LBIT7	LBIT6	LBIT5	LBIT4	LBIT3	LBIT2	LBIT1	LBIT0	R/W	L
081H	HBIT7	HBIT6	HBIT5	HBIT4	HBIT3	HBIT2	HBIT1	HBIT0	R/W	H
082H	RBIT7	RBIT6	RBIT5	RBIT4	RBIT3	RBIT2	RBIT1	RBIT0	R/W	R
083H	ZBIT7	ZBIT6	ZBIT5	ZBIT4	ZBIT3	ZBIT2	ZBIT1	ZBIT0	R/W	Z
084H	YBIT7	YBIT6	YBIT5	YBIT4	YBIT3	YBIT2	YBIT1	YBIT0	R/W	Y
086H	NT0	NPD	LVD36	LVD24		C	DC	Z	R/W	PFLAG
0A0H	TC1ENB	TC1rate2	TC1rate1	TC1rate0			TC1PO	PWM1OUT	R/W	TC1M
0A1H	TC1C7	TC1C6	TC1C5	TC1C4	TC1C3	TC1C2	TC1C1	TC1C0	R/W	TC1C
0A2H	TC1R7	TC1R6	TC1R5	TC1R4	TC1R3	TC1R2	TC1R1	TC1R0	W	TC1R
0A3H	TC1D7	TC1D6	TC1D5	TC1D4	TC1D3	TC1D2	TC1D1	TC1D0	R/W	TC1D
0A4H	TC2ENB	TC2rate2	TC2rate1	TC2rate0			TC2PO	PWM2OUT	R/W	TC2M
0A5H	TC2C7	TC2C6	TC2C5	TC2C4	TC2C3	TC2C2	TC2C1	TC2C0	R/W	TC2C
0A6H	TC2R7	TC2R6	TC2R5	TC2R4	TC2R3	TC2R2	TC2R1	TC2R0	W	TC2R
0A7H	TC2D7	TC2D6	TC2D5	TC2D4	TC2D3	TC2D2	TC2D1	TC2D0	R/W	TC2D
0A8H	TC3ENB	TC3rate2	TC3rate1	TC3rate0			TC3PO	PWM3OUT	R/W	TC3M
0A9H	TC3C7	TC3C6	TC3C5	TC3C4	TC3C3	TC3C2	TC3C1	TC3C0	R/W	TC3C
0AAH	TC3R7	TC3R6	TC3R5	TC3R4	TC3R3	TC3R2	TC3R1	TC3R0	W	TC3R
0ABH	TC3D7	TC3D6	TC3D5	TC3D4	TC3D3	TC3D2	TC3D1	TC3D0	R/W	TC3D
0ACH			PWCH31	PWCH30	PWCH21	PWCH20	PWCH11	PWCH10	R/W	PWCH
0AEH	P4CON7	P4CON6	P4CON5	P4CON4	P4CON3	P4CON2	P4CON1	P4CON0	W	P4CON
0AFH	P1CON7	P1CON6					P2CON1	P2CON0	W	P1CON
0B0H	EVHENB						VHS1	VHS0	R/W	VREFH
0B1H	ADENB	ADS	EOC	GCHS	CHS3	CHS2	CHS1	CHS0	R/W	ADM
0B2H	ADB11	ADB10	ADB9	ADB8	ADB7	ADB6	ADB5	ADB4	R	ADB
0B3H		ADCKS1	ADLEN	ADCKS0	ADB3	ADB2	ADB1	ADB0	R/W	ADR
0B4H	ADTS1	ADTS0		ADT4	ADT3	ADT2	ADT1	ADT0	R/W	ADT
0BFH			P42G1	P42G0	P41G1	P41G0	P40G1	P40G0	R/W	PEDGE
0C0H	P17W	P16W	P15W	P14W	P13W	P12W	P11W	P10W	W	P1W
0C1H	P17M	P16M	P15M	P14M	P13M	P12M	P11M	P10M	R/W	P1M
0C2H							P21M	P20M	R/W	P2M
0C4H	P47M	P46M	P45M	P44M	P43M	P42M	P41M	P40M	R/W	P4M
0C6H							TC3IRQ	TC2IRQ	R/W	INTRQ1
0C7H							TC3IEN	TC2IEN	R/W	INTEN1
0C8H	ADCIRQ	TC1IRQ	TC0IRQ	T0IRQ		P42IRQ	P41IRQ	P40IRQ	R/W	INTRQ0
0C9H	ADCIEN	TC1IEN	TC0IEN	T0IEN		P42IEN	P41IEN	P40IEN	R/W	INTEN0
0CAH				CPUM1	CPUM0	CLKMD	STPHX		R/W	OSCM
0CCH	WDTR7	WDTR6	WDTR5	WDTR4	WDTR3	WDTR2	WDTR1	WDTR0	W	WDTR
0CEH	PC7	PC6	PC5	PC4	PC3	PC2	PC1	PC0	R/W	PCL
0CFH						PC10	PC9	PC8	R/W	PCH
0D1H	P17	P16	P15	P14	P13	P12	P11	P10	R/W	P1
0D2H							P21	P20	R/W	P2
0D4H	P47	P46	P45	P44	P43	P42	P41	P40	R/W	P4
0D6H	P16SC	P15SC	P14SC	P13SC	P16DR	P15DR	P14DR	P13DR	W	P1DR
0D8H	T0ENB	T0rate2	T0rate1	T0rate0				T0TB	R/W	T0M
0D9H	T0C7	T0C6	T0C5	T0C4	T0C3	T0C2	T0C1	T0C0	R/W	T0C
0DAH	TC0ENB	TC0rate2	TC0rate1	TC0rate0	TC0CKS		TC0PO	PWM0OUT	R/W	TC0M
0DBH	TC0C7	TC0C6	TC0C5	TC0C4	TC0C3	TC0C2	TC0C1	TC0C0	R/W	TC0C
0DCH	TC0R7	TC0R6	TC0R5	TC0R4	TC0R3	TC0R2	TC0R1	TC0R0	W	TC0R
0DDH	TC0D7	TC0D6	TC0D5	TC0D4	TC0D3	TC0D2	TC0D1	TC0D0	R/W	TC0D
0DEH			PW3ES1	PW3ES0	PW2ES1	PW2ES0	PW1ES1	PW1ES0	R/W	PWES
0DFH	GIE					STKPB2	STKPB1	STKPB0	R/W	STKP
0E1H	P17R	P16R	P15R	P14R	P13R		P11R	P10R	W	P1UR
0E2H							P21R	P20R	W	P2UR
0E4H	P47R	P46R	P45R	P44R	P43R	P42R	P41R	P40R	W	P4UR
0E6H	@HL7	@HL6	@HL5	@HL4	@HL3	@HL2	@HL1	@HL0	R/W	@HL
0E7H	@YZ7	@YZ6	@YZ5	@YZ4	@YZ3	@YZ2	@YZ1	@YZ0	R/W	@YZ
0F0H	S7PC7	S7PC6	S7PC5	S7PC4	S7PC3	S7PC2	S7PC1	S7PC0	R/W	STK7L
0F1H						S7PC10	S7PC9	S7PC8	R/W	STK7H
0F2H	S6PC7	S6PC6	S6PC5	S6PC4	S6PC3	S6PC2	S6PC1	S2PC0	R/W	STK6L
0F3H						S6PC10	S6PC9	S6PC8	R/W	STK6H
0F4H	S5PC7	S5PC6	S5PC5	S5PC4	S5PC3	S5PC2	S5PC1	S5PC0	R/W	STK5L
0F5H						S1PC10	S1PC9	S5PC8	R/W	STK5H
0F6H	S4PC7	S4PC6	S4PC5	S4PC4	S4PC3	S4PC2	S4PC1	S4PC0	R/W	STK4L
0F7H						S4PC10	S4PC9	S4PC8	R/W	STK4H
0F8H	S3PC7	S3PC6	S3PC5	S3PC4	S3PC3	S3PC2	S3PC1	S3PC0	R/W	STK3L
0F9H						S3PC10	S3PC9	S3PC8	R/W	STK3H
0FAH	S2PC7	S2PC6	S2PC5	S2PC4	S2PC3	S2PC2	S2PC1	S2PC0	R/W	STK2L
0FBH						S2PC10	S2PC9	S2PC8	R/W	STK2H

0FCH	S1PC7	S1PC6	S1PC5	S1PC4	S1PC3	S1PC2	S1PC1	S1PC0	R/W	STK1L
0FDH						S1PC10	S1PC9	S1PC8	R/W	STK1H
0FEH	S0PC7	S0PC6	S0PC5	S0PC4	S0PC3	S0PC2	S0PC1	S0PC0	R/W	STK0L
0FFH						S0PC10	S0PC9	S0PC8	R/W	STK0H
0CCH	WDTR7	WDTR6	WDTR5	WDTR4	WDTR3	WDTR2	WDTR1	WDTR0	W	WDTR

* **Note:**

1. To avoid system error, make sure to put all the "0" and "1" as it indicates in the above table.
2. All of register names had been declared in SN8ASM assembler.
3. One-bit name had been declared in SN8ASM assembler with "F" prefix code.
4. "b0bset", "b0bclr", "bset", "bclr" instructions are only available to the "R/W" registers.

2.2.2 ACCUMULATOR

The ACC is an 8-bit data register responsible for transferring or manipulating data between ALU and data memory. If the result of operating is zero (Z) or there is carry (C or DC) occurrence, then these flags will be set to PFLAG register. ACC is not in data memory (RAM), so ACC can't be access by "B0MOV" instruction during the instant addressing mode.

➤ **Example: Read and write ACC value.**

; Read ACC data and store in BUF data memory

```
MOV     BUF, A
```

; Write a immediate data into ACC

```
MOV     A, #0FH
```

; Write ACC data from BUF data memory

```
MOV     A, BUF
```

The system will store ACC and PFLAG without NDT/NPD by hardware automatically when interrupt executed.

➤ **Example: Protect ACC and working registers.**

```
.CODE
INT_SERVICE:
```

```
; Save ACC to buffer.
```

```
; Save PFLAG without NDT/NPD to buffer.
```

```
...
```

```
...
```

```
; Load PFLAG without NDT/NPD form buffers.
```

```
; Load ACC form buffer.
```

```
RETI
```

```
; Exit interrupt service vector
```

2.2.3 PROGRAM FLAG

The PFLAG register contains the arithmetic status of ALU operation, system reset status and LVD detecting status. NT0, NPD bits indicate system reset status including power on reset, LVD reset, reset by external pin active and watchdog reset. C, DC, Z bits indicate the result status of ALU operation. LVD24, LVD36 bits indicate LVD detecting power voltage status.

086H	Bit 7	Bit 6	Bit 5	Bit 4	Bit 3	Bit 2	Bit 1	Bit 0
PFLAG	NT0	NPD	LVD36	LVD24	-	C	DC	Z
Read/Write	R/W	R/W	R	R	-	R/W	R/W	R/W
After reset	-	-	0	0	-	0	0	0

Bit [7:6] **NT0, NPD**: Reset status flag.

NT0	NPD	Reset Status
0	0	Watch-dog time out
0	1	Reserved
1	0	Reset by LVD
1	1	Reset by external Reset Pin

Bit 5 **LVD36**: LVD 3.6V operating flag and only support LVD code option is LVD_H.
0 = Inactive ($VDD > 3.6V$).
1 = Active ($VDD \leq 3.6V$).

Bit 4 **LVD24**: LVD 2.4V operating flag and only support LVD code option is LVD_M.
0 = Inactive ($VDD > 2.4V$).
1 = Active ($VDD \leq 2.4V$).

Bit 2 **C**: Carry flag
1 = Addition with carry, subtraction without borrowing, rotation with shifting out logic "1", comparison result ≥ 0 .
0 = Addition without carry, subtraction with borrowing signal, rotation with shifting out logic "0", comparison result < 0 .

Bit 1 **DC**: Decimal carry flag
1 = Addition with carry from low nibble, subtraction without borrow from high nibble.
0 = Addition without carry from low nibble, subtraction with borrow from high nibble.

Bit 0 **Z**: Zero flag
1 = The result of an arithmetic/logic/branch operation is zero.
0 = The result of an arithmetic/logic/branch operation is not zero.

*** Note:**

1. Refer to instruction set table for detailed information of C, DC and Z flags.
2. LVD36 bit indicate LVD detecting power voltage status. But LVD36 bit detect voltage variation range is width by power current ($F_{cpu} \uparrow$, $current \uparrow$). User must be take care the status.

2.2.4 PROGRAM COUNTER

The program counter (PC) is a 11-bit binary counter separated into the high-byte 3 and the low-byte 8 bits. This counter is responsible for pointing a location in order to fetch an instruction for kernel circuit. Normally, the program counter is automatically incremented with each instruction during program execution.

Besides, it can be replaced with specific address by executing CALL or JMP instruction. When JMP or CALL instruction is executed, the destination address will be inserted to bit 0 ~ bit 10.

	Bit 15	Bit 14	Bit 13	Bit 12	Bit 11	Bit 10	Bit 9	Bit 8	Bit 7	Bit 6	Bit 5	Bit 4	Bit 3	Bit 2	Bit 1	Bit 0
PC	-	-	-	-	-	PC10	PC9	PC8	PC7	PC6	PC5	PC4	PC3	PC2	PC1	PC0
After reset	-	-	-	-	-	0	0	0	0	0	0	0	0	0	0	0
	PCH							PCL								

☞ ONE ADDRESS SKIPPING

There are nine instructions (CMPRS, INCS, INCMS, DECS, DECMS, BTS0, BTS1, B0BTS0, B0BTS1) with one address skipping function. If the result of these instructions is true, the PC will add 2 steps to skip next instruction.

If the condition of bit test instruction is true, the PC will add 2 steps to skip next instruction.

```

                B0BTS1   FC           ; To skip, if Carry_flag = 1
                JMP      C0STEP      ; Else jump to C0STEP.
                ...
                ...
C0STEP:        NOP

                B0MOV    A, BUF0     ; Move BUF0 value to ACC.
                B0BTS0   FZ           ; To skip, if Zero flag = 0.
                JMP      C1STEP      ; Else jump to C1STEP.
                ...
                ...
C1STEP:        NOP
    
```

If the ACC is equal to the immediate data or memory, the PC will add 2 steps to skip next instruction.

```

                CMPRS    A, #12H     ; To skip, if ACC = 12H.
                JMP      C0STEP      ; Else jump to C0STEP.
                ...
                ...
C0STEP:        NOP
    
```

If the destination increased by 1, which results overflow of 0xFF to 0x00, the PC will add 2 steps to skip next instruction.

INCS instruction:

```

INCS      BUF0
JMP      C0STEP      ; Jump to C0STEP if ACC is not zero.
...

```

C0STEP:

```

...
NOP

```

INCMS instruction:

```

INCMS     BUF0
JMP      C0STEP      ; Jump to C0STEP if BUF0 is not zero.
...

```

C0STEP:

```

...
NOP

```

If the destination decreased by 1, which results underflow of 0x01 to 0x00, the PC will add 2 steps to skip next instruction.

DECS instruction:

```

DECS      BUF0
JMP      C0STEP      ; Jump to C0STEP if ACC is not zero.
...

```

C0STEP:

```

...
NOP

```

DECMS instruction:

```

DECMS     BUF0
JMP      C0STEP      ; Jump to C0STEP if BUF0 is not zero.
...

```

C0STEP:

```

...
NOP

```

☞ MULTI-ADDRESS JUMPING

Users can jump around the multi-address by either JMP instruction or ADD M, A instruction (M = PCL) to activate multi-address jumping function. Program Counter supports “ADD M,A”, ”ADC M,A” and “B0ADD M,A” instructions for carry to PCH when PCL overflow automatically. For jump table or others applications, users can calculate PC value by the three instructions and don't care PCL overflow problem.

* **Note: PCH only support PC up counting result and doesn't support PC down counting. When PCL is carry after PCL+ACC, PCH adds one automatically. If PCL borrow after PCL-ACC, PCH keeps value and not change.**

➤ Example: If PC = 0323H (PCH = 03H, PCL = 23H)

```
; PC = 0323H
      MOV      A, #28H
      B0MOV    PCL, A           ; Jump to address 0328H
      ...

; PC = 0328H
      MOV      A, #00H
      B0MOV    PCL, A           ; Jump to address 0300H
      ...
```

➤ Example: If PC = 0323H (PCH = 03H, PCL = 23H)

```
; PC = 0323H
      B0ADD    PCL, A           ; PCL = PCL + ACC, the PCH cannot be changed.
      JMP      A0POINT         ; If ACC = 0, jump to A0POINT
      JMP      A1POINT         ; ACC = 1, jump to A1POINT
      JMP      A2POINT         ; ACC = 2, jump to A2POINT
      JMP      A3POINT         ; ACC = 3, jump to A3POINT
      ...
      ...
```

2.2.5 H, L REGISTERS

The H and L registers are the 8-bit buffers. There are two major functions of these registers.

- Can be used as general working registers
- Can be used as RAM data pointers with @HL register

081H	Bit 7	Bit 6	Bit 5	Bit 4	Bit 3	Bit 2	Bit 1	Bit 0
H	HBIT7	HBIT6	HBIT5	HBIT4	HBIT3	HBIT2	HBIT1	HBIT0
Read/Write	R/W	R/W	R/W	R/W	R/W	R/W	R/W	R/W
After reset	-	-	-	-	-	-	-	-

080H	Bit 7	Bit 6	Bit 5	Bit 4	Bit 3	Bit 2	Bit 1	Bit 0
L	LBIT7	LBIT6	LBIT5	LBIT4	LBIT3	LBIT2	LBIT1	LBIT0
Read/Write	R/W	R/W	R/W	R/W	R/W	R/W	R/W	R/W
After reset	-	-	-	-	-	-	-	-

- **Example: If want to read a data from RAM address 20H of bank_0, it can use indirectly addressing mode to access data as following.**

```

B0MOV    H, #00H        ; To set RAM bank 0 for H register
B0MOV    L, #20H        ; To set location 20H for L register
B0MOV    A, @HL         ; To read a data into ACC
    
```

- **Example: Clear general-purpose data memory area of bank 0 using @HL register.**

```

CLR      H                ; H = 0, bank 0
B0MOV    L, #07FH         ; L = 7FH, the last address of the data memory area
CLR_HL_BUF:
CLR      @HL              ; Clear @HL to be zero
DECMS    L                ; L - 1, if L = 0, finish the routine
JMP      CLR_HL_BUF       ; Not zero

END_CLR:
CLR      @HL              ; End of clear general purpose data memory area of bank 0
...
    
```

2.2.6 Y, Z REGISTERS

The Y and Z registers are the 8-bit buffers. There are three major functions of these registers.

- Can be used as general working registers
- Can be used as RAM data pointers with @YZ register
- Can be used as ROM data pointer with the MOVC instruction for look-up table

084H	Bit 7	Bit 6	Bit 5	Bit 4	Bit 3	Bit 2	Bit 1	Bit 0
Y	YBIT7	YBIT6	YBIT5	YBIT4	YBIT3	YBIT2	YBIT1	YBIT0
Read/Write	R/W	R/W	R/W	R/W	R/W	R/W	R/W	R/W
After reset	-	-	-	-	-	-	-	-

083H	Bit 7	Bit 6	Bit 5	Bit 4	Bit 3	Bit 2	Bit 1	Bit 0
Z	ZBIT7	ZBIT6	ZBIT5	ZBIT4	ZBIT3	ZBIT2	ZBIT1	ZBIT0
Read/Write	R/W	R/W	R/W	R/W	R/W	R/W	R/W	R/W
After reset	-	-	-	-	-	-	-	-

➤ **Example:** Uses Y, Z register as the data pointer to access data in the RAM address 025H of bank0.

```
B0MOV    Y, #00H        ; To set RAM bank 0 for Y register
B0MOV    Z, #25H        ; To set location 25H for Z register
B0MOV    A, @YZ         ; To read a data into ACC
```

➤ **Example:** Uses the Y, Z register as data pointer to clear the RAM data.

```
B0MOV    Y, #0          ; Y = 0, bank 0
B0MOV    Z, #07FH       ; Z = 7FH, the last address of the data memory area
```

CLR_YZ_BUF:

```
CLR      @YZ            ; Clear @YZ to be zero
```

```
DECMS   Z              ; Z - 1, if Z= 0, finish the routine
JMP     CLR_YZ_BUF     ; Not zero
```

```
CLR      @YZ
```

END_CLR: ; End of clear general purpose data memory area of bank 0

...

2.2.7 R REGISTER

R register is an 8-bit buffer. There are two major functions of the register.

- Can be used as working register
- For store high-byte data of look-up table
(MOVC instruction executed, the high-byte data of specified ROM address will be stored in R register and the low-byte data will be stored in ACC).

082H	Bit 7	Bit 6	Bit 5	Bit 4	Bit 3	Bit 2	Bit 1	Bit 0
R	RBIT7	RBIT6	RBIT5	RBIT4	RBIT3	RBIT2	RBIT1	RBIT0
Read/Write	R/W	R/W	R/W	R/W	R/W	R/W	R/W	R/W
After reset	-	-	-	-	-	-	-	-

* **Note:** Please refer to the "LOOK-UP TABLE DESCRIPTION" about R register look-up table application.

2.3 ADDRESSING MODE

2.3.1 IMMEDIATE ADDRESSING MODE

The immediate addressing mode uses an immediate data to set up the location in ACC or specific RAM.

- **Example: Move the immediate data 12H to ACC.**

```
MOV      A, #12H      ; To set an immediate data 12H into ACC.
```

- **Example: Move the immediate data 12H to R register.**

```
B0MOV   R, #12H      ; To set an immediate data 12H into R register.
```

* **Note: In immediate addressing mode application, the specific RAM must be 0x80~0x87 working register.**

2.3.2 DIRECTLY ADDRESSING MODE

The directly addressing mode moves the content of RAM location in or out of ACC.

- **Example: Move 0x12 RAM location data into ACC.**

```
B0MOV   A, 12H      ; To get a content of RAM location 0x12 of bank 0 and save in ACC.
```

- **Example: Move ACC data into 0x12 RAM location.**

```
B0MOV   12H, A      ; To get a content of ACC and save in RAM location 12H of bank 0.
```

2.3.3 INDIRECTLY ADDRESSING MODE

The indirectly addressing mode is to access the memory by the data pointer registers (Y/Z).

- **Example: Indirectly addressing mode with @YZ register.**

```
B0MOV   Y, #0      ; To clear Y register to access RAM bank 0.
B0MOV   Z, #12H     ; To set an immediate data 12H into Z register.
B0MOV   A, @YZ      ; Use data pointer @YZ reads a data from RAM location
                    ; 012H into ACC.
```

2.4 STACK OPERATION

2.4.1 OVERVIEW

The stack buffer has 8-level. These buffers are designed to push and pop up program counter's (PC) data when interrupt service routine and "CALL" instruction are executed. The STKP register is a pointer designed to point active level in order to push or pop up data from stack buffer. The STKnH and STKnL are the stack buffers to store program counter (PC) data.

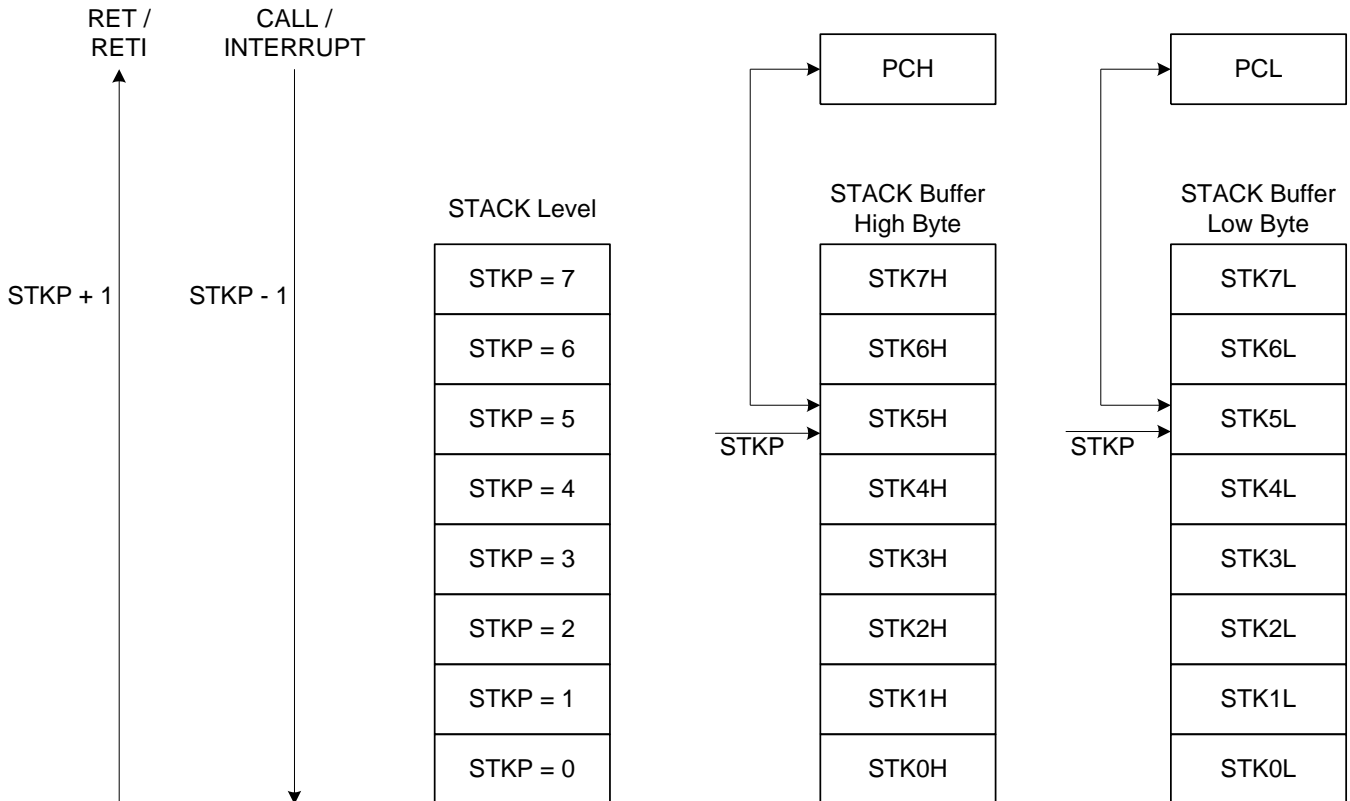

2.4.2 STACK REGISTERS

The stack pointer (STKP) is a 3-bit register to store the address used to access the stack buffer, 11-bit data memory (STK_nH and STK_nL) set aside for temporary storage of stack addresses.

The two stack operations are writing to the top of the stack (push) and reading from the top of stack (pop). Push operation decrements the STKP and the pop operation increments each time. That makes the STKP always point to the top address of stack buffer and write the last program counter value (PC) into the stack buffer.

The program counter (PC) value is stored in the stack buffer before a CALL instruction executed or during interrupt service routine. Stack operation is a LIFO type (Last in and first out). The stack pointer (STKP) and stack buffer (STK_nH and STK_nL) are located in the system register area bank 0.

0DFH	Bit 7	Bit 6	Bit 5	Bit 4	Bit 3	Bit 2	Bit 1	Bit 0
STKP	GIE	-	-	-	-	STKPB2	STKPB1	STKPB0
Read/Write	R/W	-	-	-	-	R/W	R/W	R/W
After reset	0	-	-	-	-	1	1	1

Bit[2:0] **STKPB_n**: Stack pointer (n = 0 ~ 2)

Bit 7 **GIE**: Global interrupt control bit.
0 = Disable.
1 = Enable. Please refer to the interrupt chapter.

- **Example: Stack pointer (STKP) reset, we strongly recommended to clear the stack pointer in the beginning of the program.**

```
MOV      A, #0000111B
B0MOV   STKP, A
```

0F0H~0FFH	Bit 7	Bit 6	Bit 5	Bit 4	Bit 3	Bit 2	Bit 1	Bit 0
STK_nH	-	-	-	-	-	SnPC10	SnPC9	SnPC8
Read/Write	-	-	-	-	-	R/W	R/W	R/W
After reset	-	-	-	-	-	0	0	0

0F0H~0FFH	Bit 7	Bit 6	Bit 5	Bit 4	Bit 3	Bit 2	Bit 1	Bit 0
STK_nL	SnPC7	SnPC6	SnPC5	SnPC4	SnPC3	SnPC2	SnPC1	SnPC0
Read/Write	R/W	R/W	R/W	R/W	R/W	R/W	R/W	R/W
After reset	0	0	0	0	0	0	0	0

STK_n = STK_nH , STK_nL (n = 7 ~ 0)

2.4.3 STACK OPERATION EXAMPLE

The two kinds of Stack-Save operations refer to the stack pointer (STKP) and write the content of program counter (PC) to the stack buffer are CALL instruction and interrupt service. Under each condition, the STKP decreases and points to the next available stack location. The stack buffer stores the program counter about the op-code address. The Stack-Save operation is as the following table.

Stack Level	STKP Register			Stack Buffer		Description
	STKPB2	STKPB1	STKPB0	High Byte	Low Byte	
0	1	1	1	Free	Free	-
1	1	1	0	STK0H	STK0L	-
2	1	0	1	STK1H	STK1L	-
3	1	0	0	STK2H	STK2L	-
4	0	1	1	STK3H	STK3L	-
5	0	1	0	STK4H	STK4L	-
6	0	0	1	STK5H	STK5L	-
7	0	0	0	STK6H	STK6L	-
8	1	1	1	STK7H	STK7L	-
> 8	1	1	0	-	-	Stack Over, error

There are Stack-Restore operations correspond to each push operation to restore the program counter (PC). The RETI instruction uses for interrupt service routine. The RET instruction is for CALL instruction. When a pop operation occurs, the STKP is incremented and points to the next free stack location. The stack buffer restores the last program counter (PC) to the program counter registers. The Stack-Restore operation is as the following table.

Stack Level	STKP Register			Stack Buffer		Description
	STKPB2	STKPB1	STKPB0	High Byte	Low Byte	
8	1	1	1	STK7H	STK7L	-
7	0	0	0	STK6H	STK6L	-
6	0	0	1	STK5H	STK5L	-
5	0	1	0	STK4H	STK4L	-
4	0	1	1	STK3H	STK3L	-
3	1	0	0	STK2H	STK2L	-
2	1	0	1	STK1H	STK1L	-
1	1	1	0	STK0H	STK0L	-
0	1	1	1	Free	Free	-

2.5 CODE OPTION TABLE

The code option is the system hardware configurations including system clock rate, noise filter option, watchdog timer operation, LVD option, reset pin option and OTP ROM security control. The code option items are as following table:

Code Option	Content	Function Description
Noise_Filter	Enable	Enable Noise Filter and Fcpu is Fhosc/4~Fhosc/128.
	Disable	Disable Noise Filter and Fcpu is Fhosc/1~Fhosc/128.
Fcpu	Fhosc/1	Instruction cycle is 1 oscillator clocks. Noise Filter must be disabled.
	Fhosc/2	Instruction cycle is 2 oscillator clocks. Noise Filter must be disabled.
	Fhosc/4	Instruction cycle is 4 oscillator clocks.
	Fhosc/8	Instruction cycle is 8 oscillator clocks.
	Fhosc/16	Instruction cycle is 16 oscillator clocks.
	Fhosc/32	Instruction cycle is 32 oscillator clocks.
	Fhosc/64	Instruction cycle is 64 oscillator clocks.
	Fhosc/128	Instruction cycle is 128 oscillator clocks.
High_Clk	IHRC_16M	High speed internal 16MHz RC. XIN/XOUT pins are bi-direction GPIO mode.
	IHRC_RTC	High speed internal 16MHz RC. XIN/XOUT pins are connected to external 32768Hz crystal.
	RC	Low cost RC for external high clock oscillator. XIN pin is connected to RC oscillator. XOUT pin is bi-direction GPIO mode.
	32K X'tal	Low frequency, power saving crystal (e.g. 32.768KHz) for external high clock oscillator.
	12M X'tal	High speed crystal /resonator (e.g. 12MHz) for external high clock oscillator.
	4M X'tal	Standard crystal /resonator (e.g. 4M) for external high clock oscillator.
Watch_Dog	Always_On	Watchdog timer is always on enable even in power down and green mode.
	Enable	Enable watchdog timer. Watchdog timer stops in power down mode and green mode.
	Disable	Disable Watchdog function.
Reset_Pin	Reset	Enable External reset pin.
	P12	Enable P1.2 bi-direction without pull-up resistor (Open-drain structure as output mode).
Security	Enable	Enable ROM code Security function.
	Disable	Disable ROM code Security function.
Low_Power	Enable	Enable low power to reduce operating current. Fcpu should be less than or equal to 1 MIPS.
	Disable	Disable low power option.
LVD	LVD_L	LVD will reset chip if VDD is below 2.1V
	LVD_M	LVD will reset chip if VDD is below 2.1V Enable LVD24 bit of PFLAG register for 2.4V low voltage indicator.
	LVD_H	LVD will reset chip if VDD is below 2.4V Enable LVD36 bit of PFLAG register for 3.6V low voltage indicator.

2.5.1 Fcpu code option

Fcpu means instruction cycle of normal and slow mode (high/low clock). When Noise Filter enable, Fcpu support Fhosc/4~Fhosc/128 only. Normal/Slow mode: Fhosc/1, Fhosc/2, Fhosc/4, Fhosc/8, Fhosc/16, Fhosc/32, Fhosc/64, Fhosc/128 controlled by code option.

- **Fhosc and Fhosc are same pre-scalar.**
- **If Low_Power mode enable, Fcpu should be less than or equal to 1 MIPS.**

2.5.2 Reset_Pin code option

The reset pin is shared with general input only pin controlled by code option.

- **Reset:** The reset pin is external reset function. When falling edge trigger occurring, the system will be reset.
- **P12:** Set reset pin to general input only pin (P1.2). The external reset function is disabled and the pin is bi-direction pin. Open-drain structure as output mode.

2.5.3 Security code option

Security code option is OTP ROM protection. When enable security code option, the ROM code is secured and not dumped complete ROM contents.

2.5.4 Noise Filter code option

Noise Filter code option is a power noise filter manner to reduce noisy effect of system clock. If noise filter enable, Fcpu is limited below Fhosc/1 and Fhosc/2. The fast Fcpu rate is Fhosc/4. If noise filter disable, the Fhosc/1 and Fhosc/2 options are released. In high noisy environment, enable noise filter, enable watchdog timer and select a good LVD level can make whole system work well and avoid error event occurrence.

2.5.5 Low_Power code option

The Low_Power code option can reduce operating current and only support system clock less than or equal to 1 MIPS.

- **Fcpu, Noise_Filter & Low_Power Selection Table :**

		Code Option			Remark
Low_Power	High_Clk Clock	Frequency (Hz)	Noise_Filter	Fcpu (limit)	
Enable	IHRC_16M & IHRC_RTC	16M	-	Fhosc/16~Fhosc/128	Fcpu should be less than or equal to 1 MIPS.
	External Crystal or RC	$2M < Fhosc \leq 4M$	Enable	Fhosc/4~Fhosc/128	
		$Fhosc \leq 8M$		Fhosc/8~Fhosc/128	
		$8M < Fhosc \leq 16M$		Fhosc/16~Fhosc/128	
	External Crystal or RC	$Fhosc \leq 2M$	Disable	Fhosc/2~Fhosc/128	
		$2M < Fhosc \leq 4M$		Fhosc/4~Fhosc/128	
		$4M < Fhosc \leq 8M$		Fhosc/8~Fhosc/128	
		$8M < Fhosc \leq 16M$		Fhosc/16~Fhosc/128	
Disable	IHRC_16M & IHRC_RTC	-	Enable	Fhosc/4~Fhosc/128	
	External Crystal or RC	-			
	IHRC_16M & IHRC_RTC	-	Disable	Fhosc/1~Fhosc/128	
	External Crystal or RC	-			

3 RESET

3.1 OVERVIEW

The system would be reset in three conditions as following.

- Power on reset
- Watchdog reset
- Brown out reset
- External reset (only supports external reset pin enable situation)

When any reset condition occurs, all system registers keep initial status, program stops and program counter is cleared. After reset status released, the system boots up and program starts to execute from ORG 0. The NT0, NPD flags indicate system reset status. The system can depend on NT0, NPD status and go to different paths by program.

086H	Bit 7	Bit 6	Bit 5	Bit 4	Bit 3	Bit 2	Bit 1	Bit 0
PFLAG	NT0	NPD	LVD36	LVD24	-	C	DC	Z
Read/Write	R/W	R/W	R	R	-	R/W	R/W	R/W
After reset	-	-	0	0	-	0	0	0

Bit [7:6] **NT0, NPD**: Reset status flag.

NT0	NPD	Condition	Description
0	0	Watchdog reset	Watchdog timer overflow.
0	1	Reserved	-
1	0	Power on reset and LVD reset.	Power voltage is lower than LVD detecting level.
1	1	External reset	External reset pin detect low level status.

Finishing any reset sequence needs some time. The system provides complete procedures to make the power on reset successful. For different oscillator types, the reset time is different. That causes the VDD rise rate and start-up time of different oscillator is not fixed. RC type oscillator's start-up time is very short, but the crystal type is longer. Under client terminal application, users have to take care the power on reset time for the master terminal requirement. The reset timing diagram is as following.

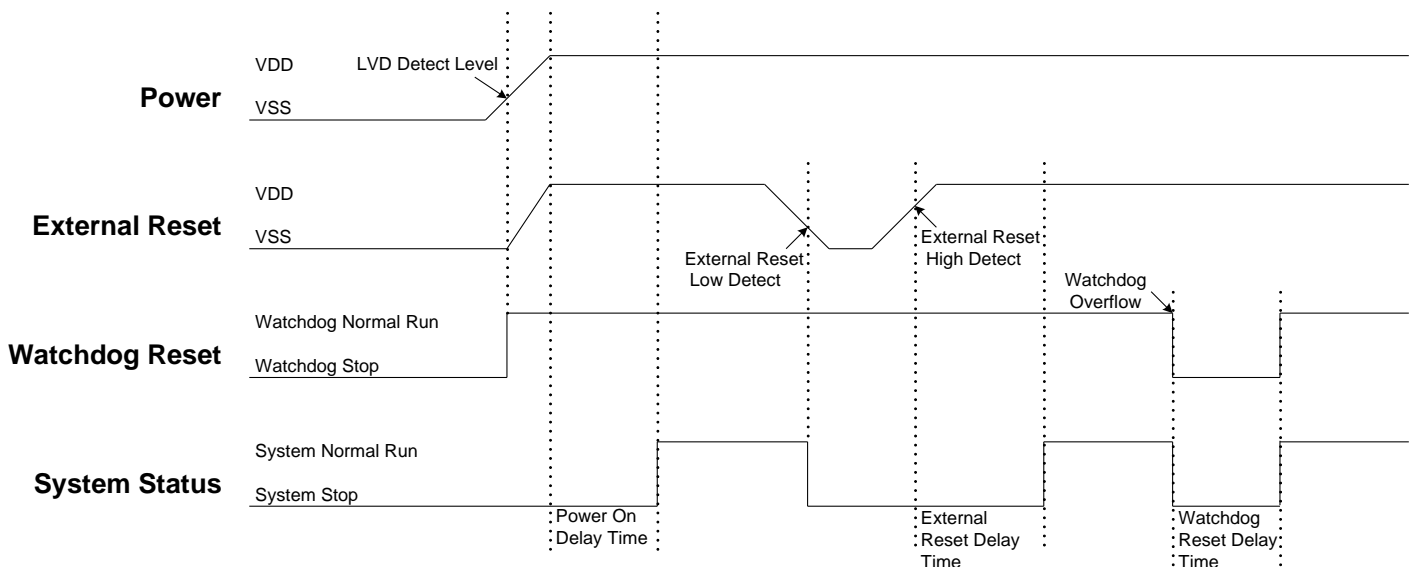

3.2 POWER ON RESET

The power on reset depend no LVD operation for most power-up situations. The power supplying to system is a rising curve and needs some time to achieve the normal voltage. Power on reset sequence is as following.

- **Power-up:** System detects the power voltage up and waits for power stable.
- **External reset (only external reset pin enable):** System checks external reset pin status. If external reset pin is not high level, the system keeps reset status and waits external reset pin released.
- **System initialization:** All system registers is set as initial conditions and system is ready.
- **Oscillator warm up:** Oscillator operation is successfully and supply to system clock.
- **Program executing:** Power on sequence is finished and program executes from ORG 0.

3.3 WATCHDOG RESET

Watchdog reset is a system protection. In normal condition, system works well and clears watchdog timer by program. Under error condition, system is in unknown situation and watchdog can't be clear by program before watchdog timer overflow. Watchdog timer overflow occurs and the system is reset. After watchdog reset, the system restarts and returns normal mode. Watchdog reset sequence is as following.

- **Watchdog timer status:** System checks watchdog timer overflow status. If watchdog timer overflow occurs, the system is reset.
- **System initialization:** All system registers is set as initial conditions and system is ready.
- **Oscillator warm up:** Oscillator operation is successfully and supply to system clock.
- **Program executing:** Power on sequence is finished and program executes from ORG 0.

Watchdog timer application note is as following.

- Before clearing watchdog timer, check I/O status and check RAM contents can improve system error.
- Don't clear watchdog timer in interrupt vector and interrupt service routine. That can improve main routine fail.
- Clearing watchdog timer program is only at one part of the program. This way is the best structure to enhance the watchdog timer function.

* **Note:** Please refer to the "WATCHDOG TIMER" about watchdog timer detail information.

3.4 BROWN OUT RESET

The brown out reset is a power dropping condition. The power drops from normal voltage to low voltage by external factors (e.g. EFT interference or external loading changed). The brown out reset would make the system not work well or executing program error.

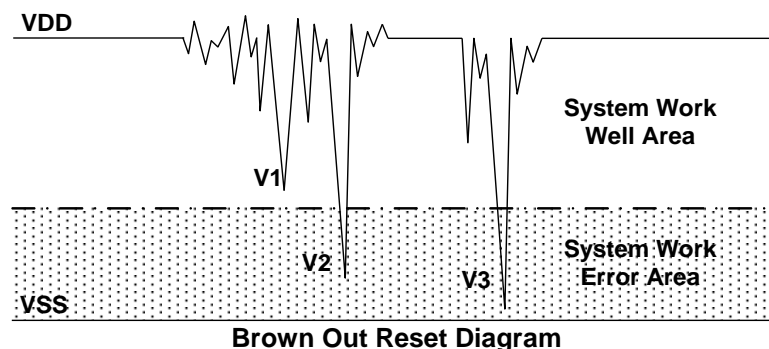

The power dropping might through the voltage range that's the system dead-band. The dead-band means the power range can't offer the system minimum operation power requirement. The above diagram is a typical brown out reset diagram. There is a serious noise under the VDD, and VDD voltage drops very deep. There is a dotted line to separate the system working area. The above area is the system work well area. The below area is the system work error area called dead-band. V1 doesn't touch the below area and not effect the system operation. But the V2 and V3 is under the below area and may induce the system error occurrence. Let system under dead-band includes some conditions.

DC application:

The power source of DC application is usually using battery. When low battery condition and MCU drive any loading, the power drops and keeps in dead-band. Under the situation, the power won't drop deeper and not touch the system reset voltage. That makes the system under dead-band.

AC application:

In AC power application, the DC power is regulated from AC power source. This kind of power usually couples with AC noise that makes the DC power dirty. Or the external loading is very heavy, e.g. driving motor. The loading operating induces noise and overlaps with the DC power. VDD drops by the noise, and the system works under unstable power situation.

The power on duration and power down duration are longer in AC application. The system power on sequence protects the power on successful, but the power down situation is like DC low battery condition. When turn off the AC power, the VDD drops slowly and through the dead-band for a while.

3.5 THE SYSTEM OPERATING VOLTAGE

To improve the brown out reset needs to know the system minimum operating voltage which is depend on the system executing rate and power level. Different system executing rates have different system minimum operating voltage. The electrical characteristic section shows the system voltage to executing rate relationship.

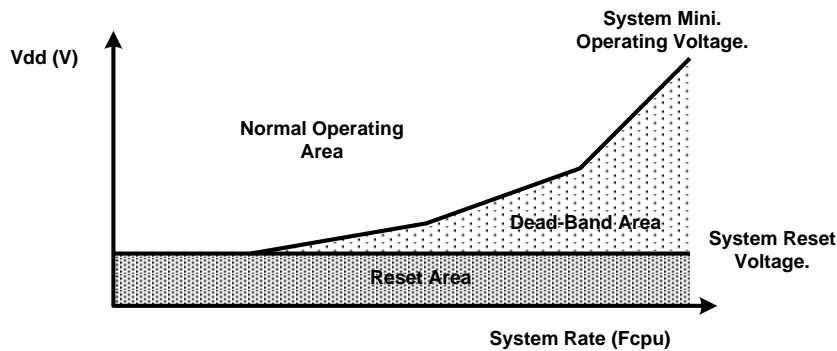

Normally the system operation voltage area is higher than the system reset voltage to VDD, and the reset voltage is decided by LVD detect level. The system minimum operating voltage rises when the system executing rate upper even higher than system reset voltage. The dead-band definition is the system minimum operating voltage above the system reset voltage.

3.6 LOW VOLTAGE DETECTOR (LVD)

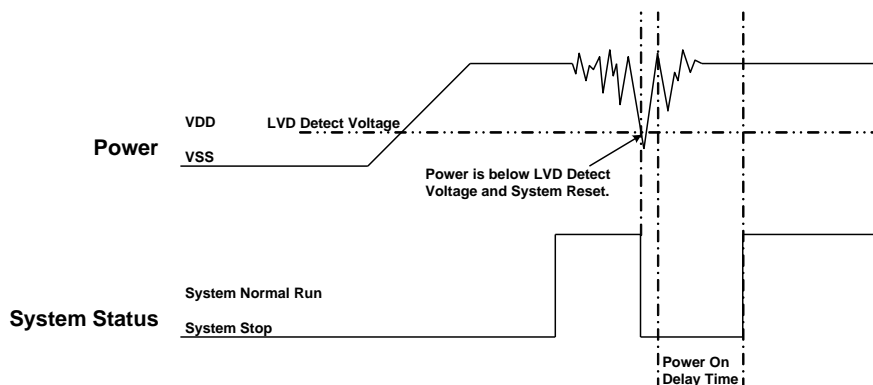

The LVD (low voltage detector) is built-in Sonix 8-bit MCU to be brown out reset protection. When the VDD drops and is below LVD detect voltage, the LVD would be triggered, and the system is reset. The LVD detect level is different by each MCU. The LVD voltage level is a point of voltage and not easy to cover all dead-band range. Using LVD to improve brown out reset is depend on application requirement and environment. If the power variation is very deep, violent and trigger the LVD, the LVD can be the protection. If the power variation can touch the LVD detect level and make system work error, the LVD can't be the protection and need to other reset methods. More detail LVD information is in the electrical characteristic section.

The LVD is three levels design (2.1V/2.4V/3.6V) and controlled by LVD code option. The 2.1V LVD is always enable for power on reset and Brown Out reset. The 2.4V LVD includes LVD reset function and flag function to indicate VDD status function. The 3.6V includes flag function to indicate VDD status. LVD flag function can be an **easy low battery detector**. LVD24, LVD36 flags indicate VDD voltage level. For low battery detect application, only checking LVD24, LVD36 status to be battery status. This is a cheap and easy solution.

086H	Bit 7	Bit 6	Bit 5	Bit 4	Bit 3	Bit 2	Bit 1	Bit 0
PFLAG	NT0	NPD	LVD36	LVD24	-	C	DC	Z
Read/Write	R/W	R/W	R	R	-	R/W	R/W	R/W
After reset	-	-	0	0	-	0	0	0

Bit 5 **LVD36:** LVD 3.6V operating flag and only support LVD code option is LVD_H.
0 = Inactive (VDD > 3.6V).
1 = Active (VDD ≤ 3.6V).

Bit 4 **LVD24:** LVD 2.4V operating flag and only support LVD code option is LVD_M.
0 = Inactive (VDD > 2.4V).
1 = Active (VDD ≤ 2.4V).

LVD	LVD Code Option		
	LVD_L	LVD_M	LVD_H
2.1V Reset	Available	Available	Available
2.4V Flag	-	Available	-
2.4V Reset	-	-	Available
3.6V Flag	-	-	Available
3.6V Reset	-	-	-

LVD_L

If VDD < 2.1V, system will be reset.
Disable LVD24 and LVD36 bit of PFLAG register.

LVD_M

If VDD < 2.1V, system will be reset.
Enable LVD24 bit of PFLAG register. If VDD > 2.4V, LVD24 is "0". If VDD ≤ 2.4V, LVD24 flag is "1".
Disable LVD36 bit of PFLAG register.

LVD_H

If VDD < 2.4V, system will be reset.
Enable LVD24 bit of PFLAG register. If VDD > 2.4V, LVD24 is "0". If VDD ≤ 2.4V, LVD24 flag is "1".
Enable LVD36 bit of PFLAG register. If VDD > 3.6V, LVD36 is "0". If VDD ≤ 3.6V, LVD36 flag is "1".

*** Note:**

1. **After any LVD reset, LVD24, LVD36 flags are cleared.**
2. **The voltage level of LVD 2.4V or 3.6V is for design reference only. Don't use the LVD indicator as precision VDD measurement.**
3. **LVD36 bit indicate LVD detecting power voltage status. But LVD36 bit detect voltage variation range is width by power current (Fcpu ↑ , current ↑). User must be take care the status)**

3.7 BROWN OUT RESET IMPROVEMENT

How to improve the brown reset condition? There are some methods to improve brown out reset as following.

- LVD reset
- Watchdog reset
- Reduce the system executing rate
- External reset circuit. (Zener diode reset circuit, Voltage bias reset circuit, External reset IC)

* **Note:**

1. *The “Zener diode reset circuit”, “Voltage bias reset circuit” and “External reset IC” can completely improve the brown out reset, DC low battery and AC slow power down conditions.*
2. *For AC power application and enhance EFT performance, the system clock is 4MHz/4 (1 mips) and use external reset (“Zener diode reset circuit”, “Voltage bias reset circuit”, “External reset IC”). The structure can improve noise effective and get good EFT characteristic.*

Watchdog reset:

The watchdog timer is a protection to make sure the system executes well. Normally the watchdog timer would be clear at one point of program. Don't clear the watchdog timer in several addresses. The system executes normally and the watchdog won't reset system. When the system is under dead-band and the execution error, the watchdog timer can't be clear by program. The watchdog is continuously counting until overflow occurrence. The overflow signal of watchdog timer triggers the system to reset, and the system return to normal mode after reset sequence. This method also can improve brown out reset condition and make sure the system to return normal mode.

If the system reset by watchdog and the power is still in dead-band, the system reset sequence won't be successful and the system stays in reset status until the power return to normal range. Watchdog timer application note is as following.

Reduce the system executing rate:

If the system rate is fast and the dead-band exists, to reduce the system executing rate can improve the dead-band. The lower system rate is with lower minimum operating voltage. Select the power voltage that's no dead-band issue and find out the mapping system rate. Adjust the system rate to the value and the system exits the dead-band issue. This way needs to modify whole program timing to fit the application requirement.

External reset circuit:

The external reset methods also can improve brown out reset and is the complete solution. There are three external reset circuits to improve brown out reset including “Zener diode reset circuit”, “Voltage bias reset circuit” and “External reset IC”. These three reset structures use external reset signal and control to make sure the MCU be reset under power dropping and under dead-band. The external reset information is described in the next section.

3.8 EXTERNAL RESET

External reset function is controlled by “Reset_Pin” code option. Set the code option as “Reset” option to enable external reset function. External reset pin is Schmitt Trigger structure and low level active. The system is running when reset pin is high level voltage input. The reset pin receives the low voltage and the system is reset. The external reset operation activates in power on and normal running mode. During system power-up, the external reset pin must be high level input, or the system keeps in reset status. External reset sequence is as following.

- **External reset (only external reset pin enable):** System checks external reset pin status. If external reset pin is not high level, the system keeps reset status and waits external reset pin released.
- **System initialization:** All system registers is set as initial conditions and system is ready.
- **Oscillator warm up:** Oscillator operation is successfully and supply to system clock.
- **Program executing:** Power on sequence is finished and program executes from ORG 0.

The external reset can reset the system during power on duration, and good external reset circuit can protect the system to avoid working at unusual power condition, e.g. brown out reset in AC power application...

3.9 EXTERNAL RESET CIRCUIT

3.9.1 Simply RC Reset Circuit

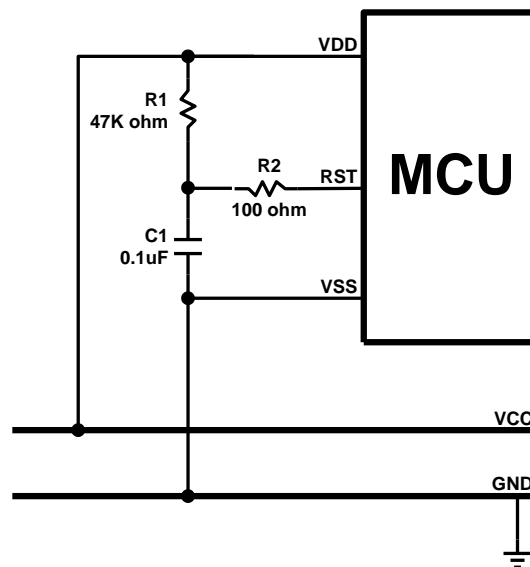

This is the basic reset circuit, and only includes R1 and C1. The RC circuit operation makes a slow rising signal into reset pin as power up. The reset signal is slower than VDD power up timing, and system occurs a power on signal from the timing difference.

* **Note:** The reset circuit is no any protection against unusual power or brown out reset.

3.9.2 Diode & RC Reset Circuit

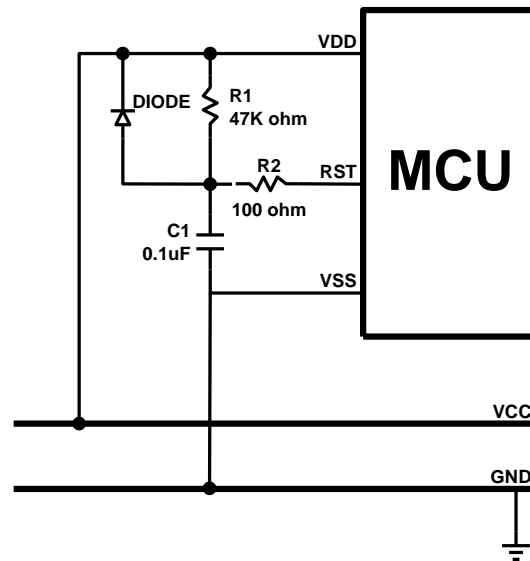

This is the better reset circuit. The R1 and C1 circuit operation is like the simply reset circuit to make a power on signal. The reset circuit has a simply protection against unusual power. The diode offers a power positive path to conduct higher power to VDD. It is can make reset pin voltage level to synchronize with VDD voltage. The structure can improve slight brown out reset condition.

* **Note:** The R2 100 ohm resistor of “Simply reset circuit” and “Diode & RC reset circuit” is necessary to limit any current flowing into reset pin from external capacitor C in the event of reset pin breakdown due to Electrostatic Discharge (ESD) or Electrical Over-stress (EOS).

3.9.3 Zener Diode Reset Circuit

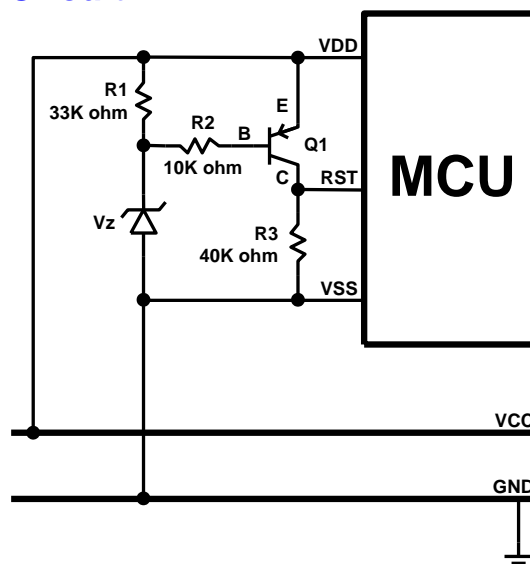

The zener diode reset circuit is a simple low voltage detector and can **improve brown out reset condition completely**. Use zener voltage to be the active level. When VDD voltage level is above “ $V_z + 0.7V$ ”, the C terminal of the PNP transistor outputs high voltage and MCU operates normally. When VDD is below “ $V_z + 0.7V$ ”, the C terminal of the PNP transistor outputs low voltage and MCU is in reset mode. Decide the reset detect voltage by zener specification. Select the right zener voltage to conform the application.

3.9.4 Voltage Bias Reset Circuit

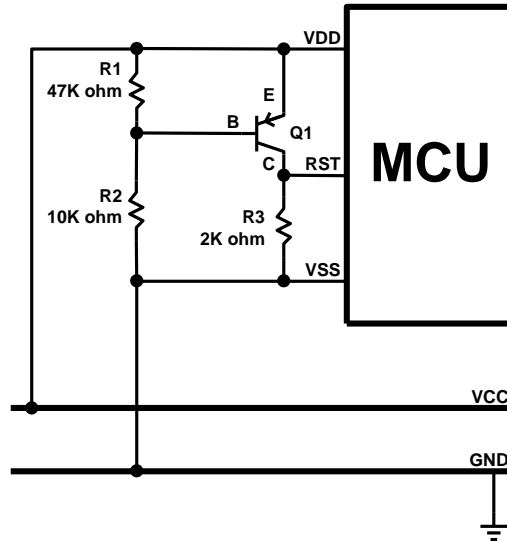

The voltage bias reset circuit is a low cost voltage detector and can **improve brown out reset condition completely**. The operating voltage is not accurate as zener diode reset circuit. Use R1, R2 bias voltage to be the active level. When VDD voltage level is above or equal to $0.7V \times (R1 + R2) / R1$, the C terminal of the PNP transistor outputs high voltage and MCU operates normally. When VDD is below $0.7V \times (R1 + R2) / R1$, the C terminal of the PNP transistor outputs low voltage and MCU is in reset mode.

Decide the reset detect voltage by R1, R2 resistances. Select the right R1, R2 value to conform the application. In the circuit diagram condition, the MCU's reset pin level varies with VDD voltage variation, and the differential voltage is 0.7V. If the VDD drops and the voltage lower than reset pin detect level, the system would be reset. If want to make the reset active earlier, set the $R2 > R1$ and the cap between VDD and C terminal voltage is larger than 0.7V. The external reset circuit is with a stable current through R1 and R2. For power consumption issue application, e.g. DC power system, the current must be considered to whole system power consumption.

* **Note:** Under unstable power condition as brown out reset, "Zener diode rest circuit" and "Voltage bias reset circuit" can protects system no any error occurrence as power dropping. When power drops below the reset detect voltage, the system reset would be triggered, and then system executes reset sequence. That makes sure the system work well under unstable power situation.

3.9.5 External Reset IC

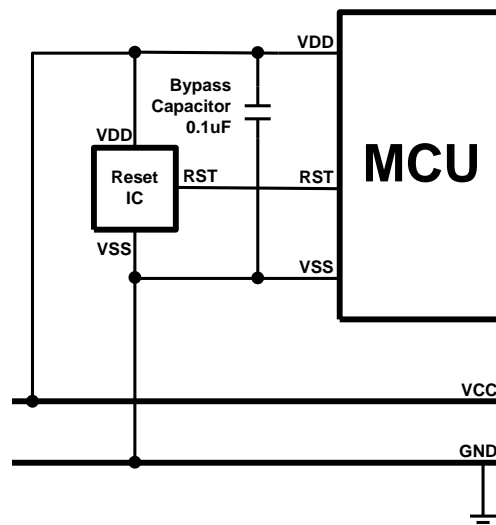

The external reset circuit also use external reset IC to enhance MCU reset performance. This is a high cost and good effect solution. By different application and system requirement to select suitable reset IC. The reset circuit can improve all power variation.

4 SYSTEM CLOCK

4.1 OVERVIEW

The micro-controller is a dual clock system including high-speed and low-speed clocks. The high-speed clock includes internal high-speed oscillator and external oscillators selected by “High_CLK” code option. The low-speed clock is from internal low-speed oscillator controlled by “CLKMD” bit of OSCM register. Both high-speed clock and low-speed clock can be system clock source through a divider to decide the system clock rate.

- **High-speed oscillator**

Internal high-speed oscillator is 16MHz RC type called “IHRC” and “IHRC_RTC”. External high-speed oscillator includes crystal/ceramic (4MHz, 12MHz, 32KHz) and RC type.

- **Low-speed oscillator**

Internal low-speed oscillator is 16KHz @3V, 32KHz @5V RC type called “ILRC”.

- **System clock block diagram**

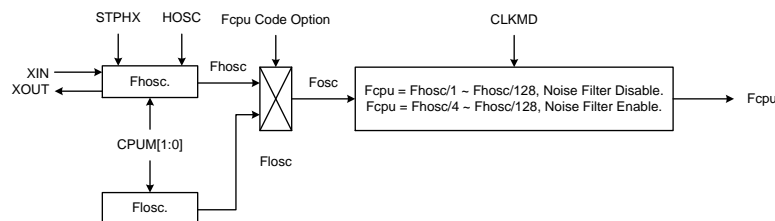

- HOSC: High_Clk code option.
- Fhosc: External high-speed clock / internal high-speed RC clock.
- Flosc: Internal low-speed RC clock (about 16KHz@3V, 32KHz@5V).
- Fosc: System clock source.
- Fcpu: Instruction cycle.

SONiX provides a “Noise Filter” controlled by code option. In high noisy situation, the noise filter can isolate noise outside and protect system works well. The minimum Fcpu of high clock is limited at **Fhosc/4** when noise filter enable.

4.2 FCPU (INSTRUCTION CYCLE)

The system clock rate is instruction cycle called “Fcpu” which is divided from the system clock source and decides the system operating rate. Fcpu rate is selected by Fcpu code option and the range is **Fosc/1~Fosc/128** under system normal mode. If the system high clock source is external 16MHz crystal, and the Fcpu code option is Fhosc/16, the Fcpu frequency is 16MHz/16 = 1MHz. Fhosc and Flosc are same pre-scalar. Under system slow mode, the Fcpu is Flosc/16, 16KHz/16=1KHz @3V, 32KHz/16=2KHz @5V.

The Fcpu range is limited by noise filter code option. If noise filter code option is disabled, the Fcpu range is Fosc/1~Fosc/128. If noise filter code option is enabled, the Fcpu range is Fosc/4~Fosc/128 to reduce noise effect.

4.3 NOISE FILTER

The Noise Filter controlled by “Noise_Filter” code option is a low pass filter and supports internal high-speed RC clock / external oscillator including RC and crystal modes. The purpose is to filter high rate noise coupling on high clock signal from oscillator.

In high noisy environment, enable “Noise_Filter” code option is the strongly recommendation to reduce noise effect.

4.4 SYSTEM HIGH-SPEED CLOCK

The system high-speed clock has internal and external two-type. The external high-speed clock includes 4MHz, 12MHz, 32KHz crystal/ceramic and RC type. These high-speed oscillators are selected by “High_CLK” code option. The internal high-speed clock supports real time clock (RTC) function. Under “IHRC_RTC” mode, the internal high-speed clock and external 32KHz oscillator active. The internal high-speed clock is the system clock source, and the external 32KHz oscillator is the RTC clock source to supply a accurately real time clock rate.

4.5 HIGH_CLK CODE OPTION

For difference clock functions, Sonix provides multi-type system high clock options controlled by “High_CLK” code option. The High_CLK code option defines the system oscillator types including IHRC_16M, IHRC_RTC, RC, 32K X’tal, 12M X’tal and 4M X’tal. These oscillator options support different bandwidth oscillator.

- **IHRC_16M:** The system high-speed clock source is internal high-speed 16MHz RC type oscillator. In the mode, XIN and XOUT pins are bi-direction GPIO mode, and not to connect any external oscillator device.
- **IHRC_RTC:** The system high-speed clock source is internal high-speed 16MHz RC type oscillator. The RTC clock source is external low-speed 32768Hz crystal. The XIN and XOUT pins are defined to drive external 32768Hz crystal and disables GPIO function.
- **RC:** The system high-speed clock source is external low cost RC type oscillator. The RC oscillator circuit only connects to XIN pin, and the XOUT pin is bi-direction GPIO mode.
- **32K X’tal:** The system high-speed clock source is external low-speed 32768Hz crystal. The option only supports 32768Hz crystal and the RTC function is workable.
- **12M X’tal:** The system high-speed clock source is external high-speed crystal/ceramic. The oscillator bandwidth is 10MHz~16MHz.
- **4M X’tal:** The system high-speed clock source is external high-speed crystal/resonator. The oscillator bandwidth is 1MHz~10MHz.

For power consumption under “IHRC_RTC” mode, the internal high/low-speed oscillator and external 32KHz crystal always running under normal to green mode. The internal high-speed oscillator is controlled by FSTPHX=1 under slow to green mode.

4.5.1 INTERNAL HIGH-SPEED OSCILLATOR RC TYPE (IHRC)

The internal high-speed oscillator is 16MHz RC type. The accuracy is $\pm 2\%$ under commercial condition. When the “High_CLK” code option is “IHRC_16M” or “IHRC_RTC”, the internal high-speed oscillator is enabled.

- **IHRC_16M:** The system high-speed clock is internal 16MHz oscillator RC type. XIN/XOUT pins are general purpose I/O pins.
- **IHRC_RTC:** The system high-speed clock is internal 16MHz oscillator RC type, and the real time clock is external 32768Hz crystal. XIN/XOUT pins connect with external 32768Hz crystal.

4.5.2 EXTERNAL HIGH-SPEED OSCILLATOR

The external high-speed oscillator includes 4MHz, 12MHz, 32KHz and RC type. The 4MHz, 12MHz and 32KHz oscillators support crystal and ceramic types connected to XIN/XOUT pins with 20pF capacitors to ground. The RC type is a low cost RC circuit only connected to XIN pin. The capacitance is not below 100pF, and use the resistance to decide the frequency.

4.5.3 EXTERNAL OSCILLATOR APPLICATION CIRCUIT

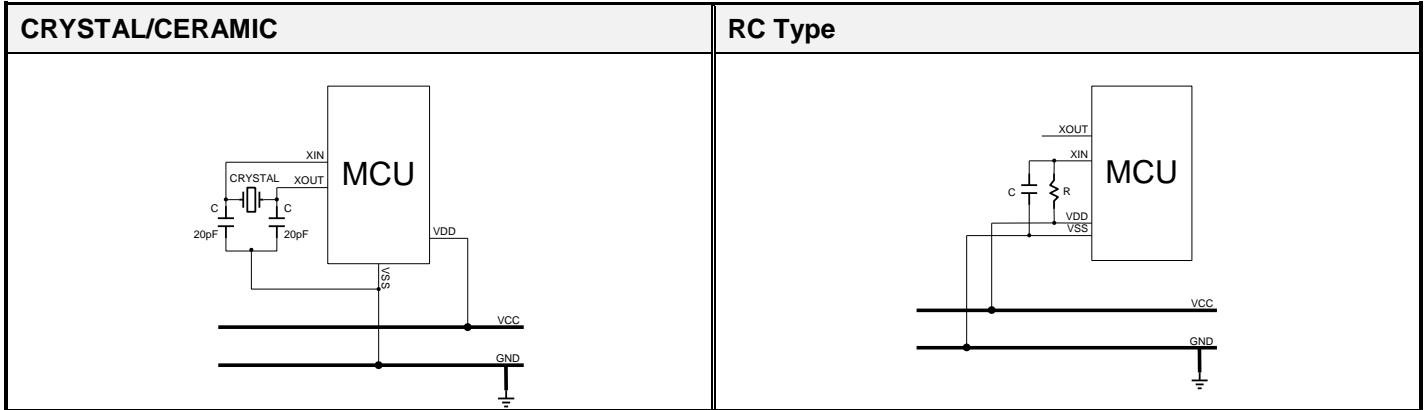

* **Note:** Connect the Crystal/Ceramic and C as near as possible to the XIN/XOUT/VSS pins of micro-controller. Connect the R and C as near as possible to the VDD pin of micro-controller.

4.6 SYSTEM LOW-SPEED CLOCK

The system low clock source is the internal low-speed oscillator built in the micro-controller. The low-speed oscillator uses RC type oscillator circuit. The frequency is affected by the voltage and temperature of the system. In common condition, the frequency of the RC oscillator is about 16KHz at 3V and 32KHz at 5V. The relation between the RC frequency and voltage is as the following figure.

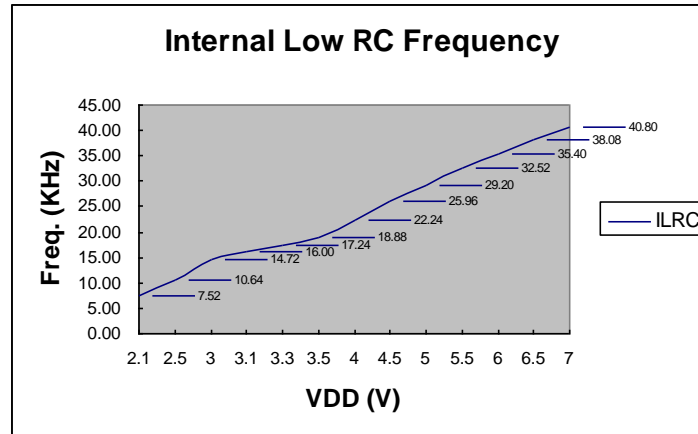

The internal low RC supports watchdog clock source and system slow mode controlled by “CLKMD” bit of OSCM register.

- ***F_{osc}* = Internal low RC oscillator (about 16KHz @3V, 32KHz @5V).**
- ***Slow mode F_{cpu}* = *F_{osc}* / 1~*F_{osc}*/128 (*F_{osc}* rate is controlled by code option).**

There are two conditions to stop internal low RC. One is power down mode, and the other is green mode of 32K mode and watchdog disable.

➤ **Example: Stop internal low-speed oscillator by power down mode.**

```
B0BSET    FCPUM0           ; To stop external high-speed oscillator and internal low-speed
                                ; oscillator called power down mode (sleep mode).
```

* **Note: The internal low-speed clock can't be turned off individually. It is controlled by CPUM0, CPUM1 bits of OSCM register.**

4.7 OSCM REGISTER

The OSCM register is an oscillator control register. It controls oscillator status, system mode.

OCAH	Bit 7	Bit 6	Bit 5	Bit 4	Bit 3	Bit 2	Bit 1	Bit 0
OSCM	0	0	0	CPUM1	CPUM0	CLKMD	STPHX	0
Read/Write	-	-	-	R/W	R/W	R/W	R/W	-
After reset	-	-	-	0	0	0	0	-

- Bit 1 **STPHX**: External high-speed oscillator control bit.
0 = External high-speed oscillator free run.
1 = External high-speed oscillator free run stop. Internal low-speed RC oscillator is still running.
- Bit 2 **CLKMD**: System high/Low clock mode control bit.
0 = Normal (dual) mode. System clock is high clock.
1 = Slow mode. System clock is internal low clock.
- Bit[4:3] **CPUM[1:0]**: CPU operating mode control bits.
00 = normal.
01 = sleep (power down) mode.
10 = green mode.
11 = reserved.

“STPHX” bit controls internal high speed RC type oscillator and external oscillator operations. When “STPHX=0”, the external oscillator or internal high speed RC type oscillator active. When “STPHX=1”, the external oscillator or internal high speed RC type oscillator are disabled. The STPHX function is depend on different high clock options to do different controls.

- **IHRC_16M**: “STPHX=1” disables internal high speed RC type oscillator.
- **IHRC_RTC**: “STPHX=1” disables internal high speed RC type oscillator, and external 32768Hz crystal keeps oscillating.
- **RC, 4M, 12M, 32K**: “STPHX=1” disables external oscillator.

4.8 SYSTEM CLOCK MEASUREMENT

Under design period, the users can measure system clock speed by software instruction cycle (Fcpu). This way is useful in RC mode.

➤ **Example: Fcpu instruction cycle of external oscillator.**

```
B0BSET    P1M.0           ; Set P1.0 to be output mode for outputting Fcpu toggle signal.
```

@@:

```
B0BSET    P1.0           ; Output Fcpu toggle signal in normal mode.
B0BCLR    P1.0           ; Measure the Fcpu frequency by oscilloscope.
JMP       @B
```

* **Note: Do not measure the RC frequency directly from XIN; the probe impedance will affect the RC frequency.**

4.9 SYSTEM CLOCK TIMING

Parameter	Symbol	Description	Typical
Hardware configuration time	Tcfg	$2048 * F_{ILRC}$	64ms @ $F_{ILRC} = 32\text{KHz}$ 128ms @ $F_{ILRC} = 16\text{KHz}$
Oscillator start up time	Tost	The start-up time is depended on oscillator's material, factory and architecture. Normally, the low-speed oscillator's start-up time is lower than high-speed oscillator. The RC type oscillator's start-up time is faster than crystal type oscillator.	-
Oscillator warm-up time	Tosp	Oscillator warm-up time of reset condition. $2048 * F_{hosc}$ (Power on reset, LVD reset, watchdog reset, external reset pin active.)	64ms @ $F_{hosc} = 32\text{KHz}$ 512us @ $F_{hosc} = 4\text{MHz}$ 128us @ $F_{hosc} = 16\text{MHz}$
		Oscillator warm-up time of power down mode wake-up condition. $2048 * F_{hosc}$Crystal/resonator type oscillator, e.g. 32768Hz crystal, 4MHz crystal, 16MHz crystal... $32 * F_{hosc}$RC type oscillator, e.g. external RC type oscillator, internal high-speed RC type oscillator.	X'tal: 64ms @ $F_{hosc} = 32\text{KHz}$ 512us @ $F_{hosc} = 4\text{MHz}$ 128us @ $F_{hosc} = 16\text{MHz}$ RC: 8us @ $F_{hosc} = 4\text{MHz}$ 2us @ $F_{hosc} = 16\text{MHz}$

● Power On Reset Timing

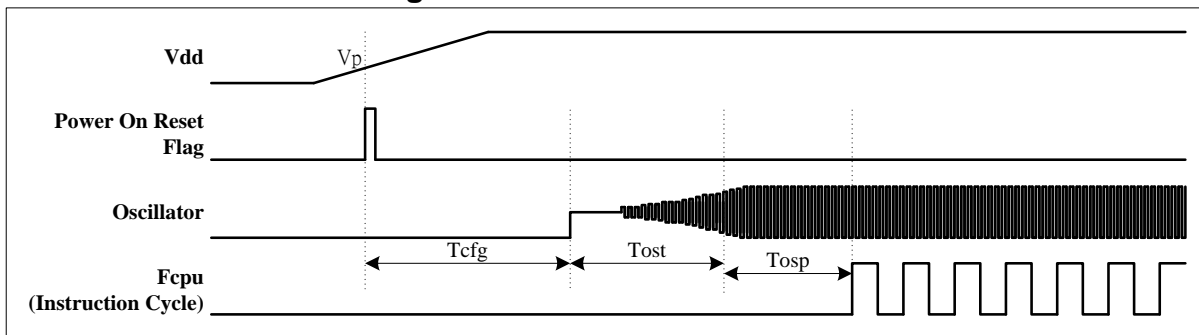

● External Reset Pin Reset Timing

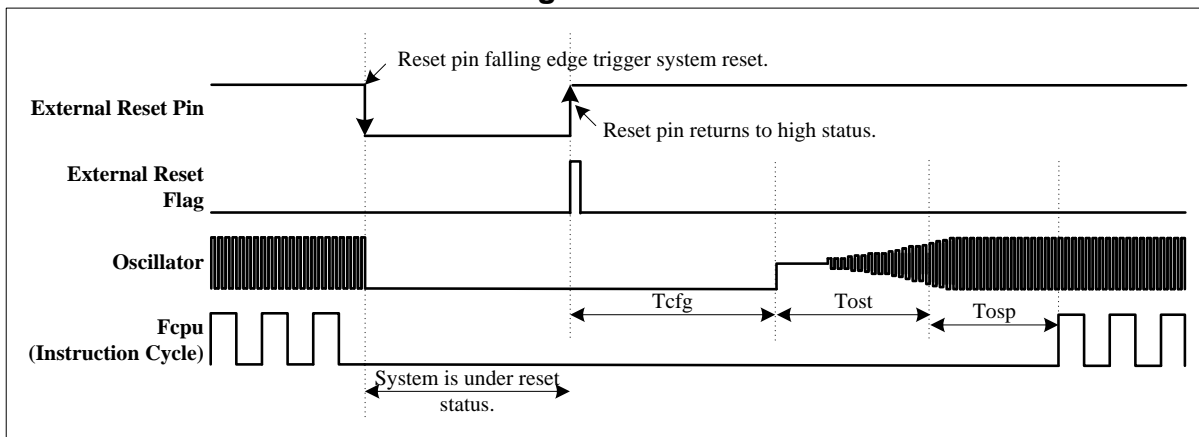

● **Watchdog Reset Timing**

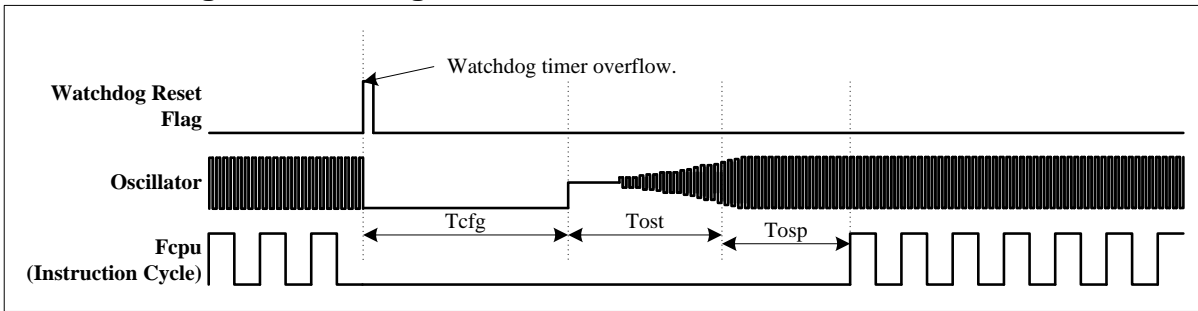

● **Power Down Mode Wake-up Timing**

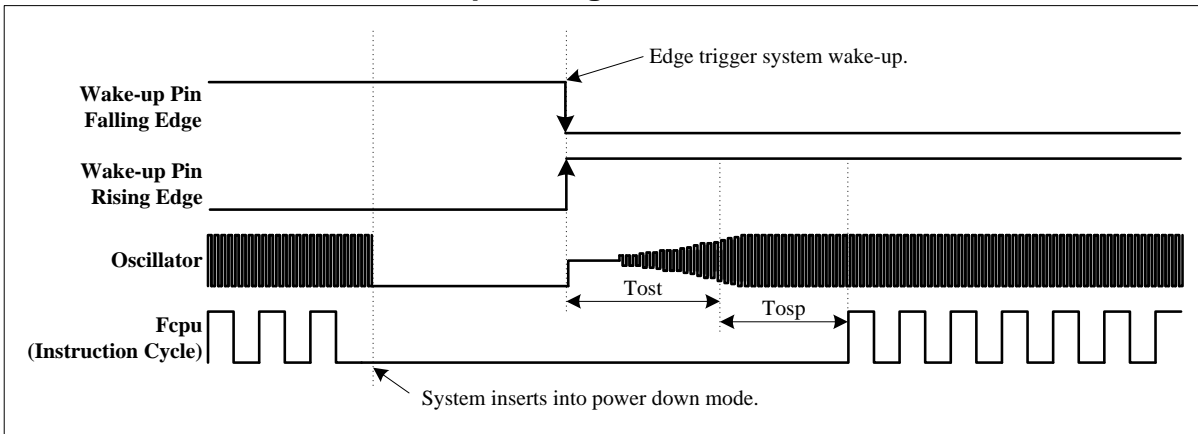

● **Green Mode Wake-up Timing**

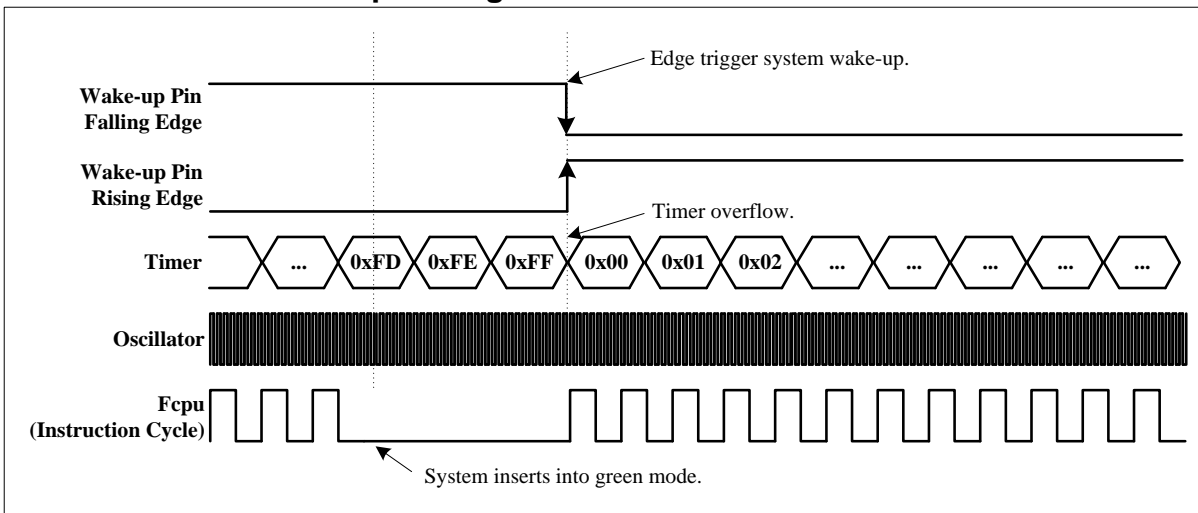

● Oscillator Start-up Time

The start-up time is depended on oscillator's material, factory and architecture. Normally, the low-speed oscillator's start-up time is lower than high-speed oscillator. The RC type oscillator's start-up time is faster than crystal type oscillator.

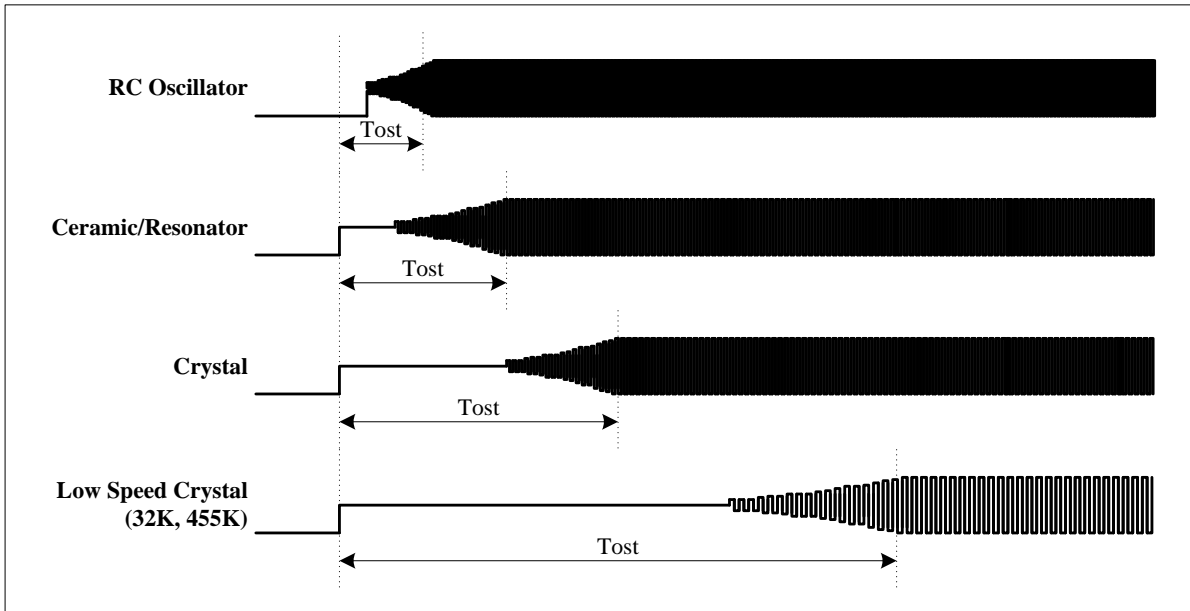

5 SYSTEM OPERATION MODE

5.1 OVERVIEW

The chip builds in four operating mode for difference clock rate and power saving reason. These modes control oscillators, op-code operation and analog peripheral devices' operation.

- Normal mode: System high-speed operating mode.
- Slow mode: System low-speed operating mode.
- Power down mode: System power saving mode (Sleep mode).
- Green mode: System ideal mode.

Operating Mode Control Block

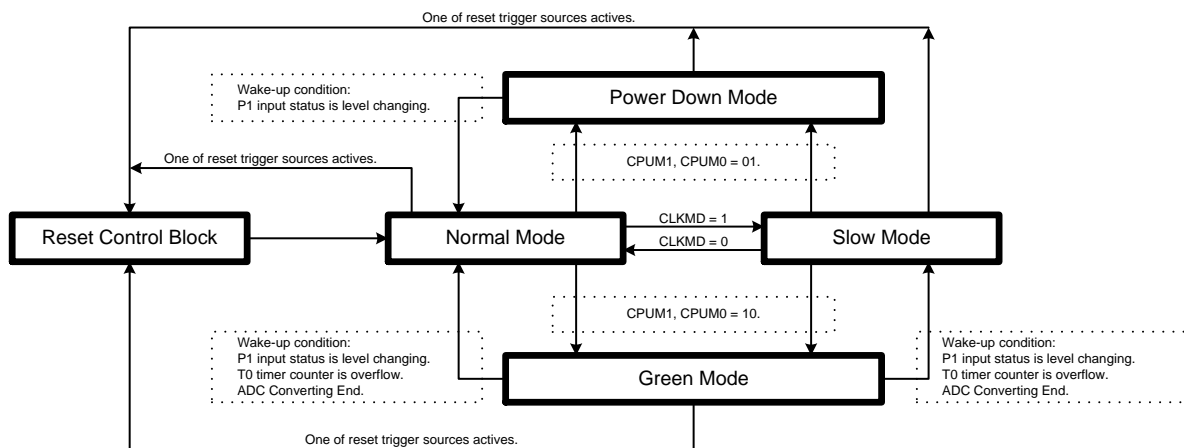

Operating Mode Clock Control Table

Operating Mode	Normal Mode	Slow Mode	Green Mode	Power Down Mode
IHRC	IHRC, IHRC_RTC: Running Ext. OSC: Disable	IHRC, IHRC_RTC: By STPHX Ext. OSC: Disable	IHRC, IHRC_RTC: By STPHX Ext. OSC: Disable	Stop
ILRC	Running	Running	Running	Stop
Ext. Osc.	IHRC: Disable IHRC_RTC, Ext. OSC: Running	IHRC: Disable IHRC_RTC: Running Ext. OSC: By STPHX	IHRC: Disable IHRC_RTC: Running Ext. OSC: By STPHX	Stop
CPU instruction	Executing	Executing	Stop	Stop
T0 timer	Active By TOENB	Active By TOENB	Active By TOENB	Inactive
TC0 timer (Timer, Event counter, PWM)	Active By TC0ENB	Active By TC0ENB	Active By TC0ENB	Inactive
TC1-TC3 timer (Timer, PWM)	Active By TC1ENB By TC2ENB By TC3ENB	Active By TC1ENB By TC2ENB By TC3ENB	Active By TC1ENB By TC2ENB By TC3ENB	Inactive
ADC	Active as enable	Active as enable	Active as enable	Inactive
Watchdog timer	By Watch_Dog Code option	By Watch_Dog Code option	By Watch_Dog Code option	By Watch_Dog Code option
Internal interrupt	All active	All active	All active	All inactive
External interrupt	All active	All active	All active	All inactive
Wakeup source	-	-	ADC, P1, T0, Reset	P1, Reset

- **Ext.Osc:** External high-speed oscillator (XIN/XOUT).
- **IHRC:** Internal high-speed oscillator RC type.
- **ILRC:** Internal low-speed oscillator RC type.

* **Note:** In IHRC_RTC mode, STPHX only controls IHRC, not Ext. 32K. STPHX=0, IHRC actives. STPHX=1, IHRC stops.

5.2 NORMAL MODE

The Normal Mode is system high clock operating mode. The system clock source is from high speed oscillator. The program is executed. After power on and any reset trigger released, the system inserts into normal mode to execute program. When the system is wake-up from power down mode, the system also inserts into normal mode. In normal mode, the high speed oscillator actives, and the power consumption is largest of all operating modes.

- The program is executed, and full functions are controllable.
- The system rate is high speed.
- The high speed oscillator and internal low speed RC type oscillator active.
- Normal mode can be switched to other operating modes through OSCM register.
- Power down mode is wake-up to normal mode.
- Slow mode is switched to normal mode.
- Green mode from normal mode is wake-up to normal mode.

5.3 SLOW MODE

The slow mode is system low clock operating mode. The system clock source is from internal low speed RC type oscillator. The slow mode is controlled by CLKMD bit of OSCM register. When CLKMD=0, the system is in normal mode. When CLKMD=1, the system inserts into slow mode. The high speed oscillator won't be disabled automatically after switching to slow mode, and must be disabled by SPTHX bit to reduce power consumption. In slow mode, the system rates are $F_{osc}/1 \sim F_{osc}/128$ (F_{osc} is internal low speed RC type oscillator frequency) controlled by code option. F_{osc} and F_{osc} are same pre-scalar.

- The program is executed, and full functions are controllable.
- The system rate is low speed ($F_{osc}/1 \sim F_{osc}/128$ controlled by code option. F_{osc} and F_{osc} are same pre-scalar.).
- The internal low speed RC type oscillator actives, and the high speed oscillator is controlled by STPHX=1. In slow mode, to stop high speed oscillator is strongly recommendation.
- Slow mode can be switched to other operating modes through OSCM register.
- Power down mode from slow mode is wake-up to normal mode.
- Normal mode is switched to slow mode.
- Green mode from slow mode is wake-up to slow mode.

5.4 POWER DOWN MDOE

The power down mode is the system ideal status. No program execution and oscillator operation. Whole chip is under low power consumption status under 1uA. The power down mode is waked up by P1 hardware level change trigger. Any operating modes into power down mode, the system is waked up to normal mode. Inserting power down mode is controlled by CPUM0 bit of OSCM register. When CPUM0=1, the system inserts into power down mode. After system wake-up from power down mode, the CPUM0 bit is disabled (zero status) automatically.

- The program stops executing, and full functions are disabled.
- All oscillators including external high speed oscillator, internal high speed oscillator and internal low speed oscillator stop.
- The power consumption is under 1uA.
- The system inserts into normal mode after wake-up from power down mode.
- The power down mode wake-up source is P1 level change trigger.

* **Note: If the system is in normal mode, to set STPHX=1 to disable the high clock oscillator. The system is under no system clock condition. This condition makes the system stay as power down mode, and can be wake-up by P1 level change trigger.**

5.5 GREEN MODE

The green mode is another system ideal status not like power down mode. In power down mode, all functions and hardware devices are disabled. But in green mode, the system clock source keeps running, so the power consumption of green mode is larger than power down mode. In green mode, the program isn't executed, but the timer with wake-up function actives as enabled, and the timer clock source is the non-stop system clock. The green mode has 2 wake-up sources. One is the P1 level change trigger wake-up. The other one is internal timer with wake-up function occurring overflow. That's mean users can setup one fix period to timer, and the system is waked up until the time out. Inserting green mode is controlled by CPUM1 bit of OSCM register. When CPUM1=1, the system inserts into green mode. After system wake-up from green mode, the CPUM1 bit is disabled (zero status) automatically.

- The program stops executing, and full functions are disabled.
- Only the timer (T0) with wake-up function actives.
- The oscillator to be the system clock source keeps running, and the other oscillators operation is depend on system operation mode configuration.
- If inserting green mode from normal mode, the system insets to normal mode after wake-up.
- If inserting green mode from slow mode, the system insets to slow mode after wake-up.
- The green mode wake-up sources are P1 level change trigger and unique time overflow.
- PWM output function active in green mode, but the timers (TC0/TC1) can't wake-up the system as overflow.

* **Note: Sonix provides "GreenMode" macro to control green mode operation. It is necessary to use "GreenMode" macro to control system inserting green mode. The macro includes three instructions. Please take care the macro length as using BRANCH type instructions, e.g. bts0, bts1, b0bts0, b0bts1, incs, incms, decs, decms, cmprs, jmp, or the routine would be error.**

5.6 OPERATING MODE CONTROL MACRO

Sonix provides operating mode control macros to switch system operating mode easily.

Macro	Length	Description
SleepMode	1-word	The system insets into Sleep Mode (Power Down Mode).
GreenMode	3-word	The system inserts into Green Mode.
SlowMode	2-word	The system inserts into Slow Mode and stops high speed oscillator.
Slow2Normal	5-word	The system returns to Normal Mode from Slow Mode. The macro includes operating mode switch, enable high speed oscillator, high speed oscillator warm-up delay time.

- **Example: Switch normal/slow mode to power down (sleep) mode.**

```
SleepMode ; Declare "SleepMode" macro directly.
```

- **Example: Switch normal mode to slow mode.**

```
SlowMode ; Declare "SlowMode" macro directly.
```

- **Example: Switch slow mode to normal mode (The external high-speed oscillator stops).**

```
Slow2Normal ; Declare "Slow2Normal" macro directly.
```

- **Example: Switch normal/slow mode to green mode.**

```
GreenMode ; Declare "GreenMode" macro directly.
```

- **Example: Switch normal/slow mode to green mode and enable T0 wake-up function.**

```
; Set T0 timer wakeup function.
```

```
BOBCLR FT0IEN ; To disable T0 interrupt service
BOBCLR FT0ENB ; To disable T0 timer
MOV A,#30H ;
BOMOV T0M,A ; To set T0 clock = Fosc / 16 (Fosc = 16MHz)
MOV A,#9CH ;
BOMOV T0C,A ; To set T0C initial value = 9CH (To set T0 interval = 0.1 ms)
BOBCLR FT0IEN ; To disable T0 interrupt service
BOBCLR FT0IRQ ; To clear T0 interrupt request
BOBSET FT0ENB ; To enable T0 timer
```

```
; Go into green mode
```

```
GreenMode ; Declare "GreenMode" macro directly.
```

- **Example: Switch normal/slow mode to green mode and enable T0 wake-up function with RTC.**

```
CLR T0C ; Clear T0 counter.
BOBSET FT0TB ; Enable T0 RTC function.
BOBSET FT0ENB ; To enable T0 timer.
```

```
; Go into green mode
```

```
GreenMode ; Declare "GreenMode" macro directly.
```

5.7 WAKEUP

5.7.1 OVERVIEW

Under power down mode (sleep mode) or green mode, program doesn't execute. The wakeup trigger can wake the system up to normal mode or slow mode. The wakeup trigger sources are external trigger (P1 level change) and internal trigger (T0 timer overflow).

- Power down mode is waked up to normal mode. The wakeup trigger is only external trigger (P1 level change).
- Green mode is waked up to last mode (normal mode or slow mode). The wakeup triggers are external trigger (P1 level change) and internal trigger (T0 timer overflow).

5.7.2 WAKEUP TIME

When the system is in power down mode (sleep mode), the high clock oscillator stops. When waked up from power down mode, MCU waits a period for stabilizing the oscillator circuit. After the wakeup time, the system goes into the normal mode.

* **Note: Wakeup from green mode is no wakeup time because the clock doesn't stop in green mode.**

The wake-up time of the **external high-speed crystal type oscillator (12M_X'tal, 4M_X'tal, 32K_X'tal)** is as the following.

$$\text{The Wakeup time} = 1/F_{osc} * 2048 \text{ (sec)} + \text{high clock start-up time}$$

- **Example: In power down mode (sleep mode), the system is waked up. After the wakeup time, the system goes into normal mode. The wakeup time is as the following.**

$$\begin{aligned} \text{The wakeup time} &= 1/F_{osc} * 2048 = 0.512 \text{ ms (4MHz crystal)} \\ \text{The total wakeup time} &= 0.512 \text{ ms} + \text{oscillator start-up time} \end{aligned}$$

The wake-up time of the **internal / external high speed RC type oscillator (IHRC, IHRC_RTC, Ext_RC)** is as the following.

$$\text{The Wakeup time} = 1/F_{osc} * 32 \text{ (sec)} + \text{clock start-up time}$$

- **Example: In power down mode (sleep mode), the system is waked up. After the wakeup time, the system goes into normal mode. The wakeup time is as the following.**

$$\begin{aligned} \text{The wakeup time} &= 1/F_{osc} * 32 = 2 \text{ us (IHRC, IHRC_RTC, IHRC = 16MHz)} \\ \text{The total wakeup time} &= 2 \text{ us} + \text{oscillator start-up time} \end{aligned}$$

* **Note: The high clock start-up time is depended on the VDD and oscillator type of high clock.**

5.7.3 P1W WAKEUP CONTROL REGISTER

Under power down mode (sleep mode) and green mode, the I/O ports with wakeup function are able to wake the system up to normal mode. The wake-up trigger edge is level changing. When wake-up pin occurs rising edge or falling edge, the system is waked up by the trigger edge. The Port 1 has wakeup function. Port 1 is controlled by the P1W register.

0C0H	Bit 7	Bit 6	Bit 5	Bit 4	Bit 3	Bit 2	Bit 1	Bit 0
P1W	P17W	P16W	P15W	P14W	P13W	P12W	P11W	P10W
Read/Write	W	W	W	W	W	W	W	W
After reset	0	0	0	0	0	0	0	0

Bit[7:0] **P10W~P17W**: Port 1 wakeup function control bits.
0 = Disable P1n wakeup function.
1 = Enable P1n wakeup function.

6 INTERRUPT

6.1 OVERVIEW

This MCU provides nine interrupt sources, including six internal interrupts (T0/TC0/TC1/TC2/TC3/ADC) and three external interrupts (INT0/INT1/INT2). The external interrupt can wakeup the chip while the system is switched from power down mode to high-speed normal mode. Once interrupt service is executed, the GIE bit in STKP register will clear to “0” for stopping other interrupt request. On the contrast, when interrupt service exits, the GIE bit will set to “1” to accept the next interrupts’ request. All of the interrupt request signals are stored in INTRQ register.

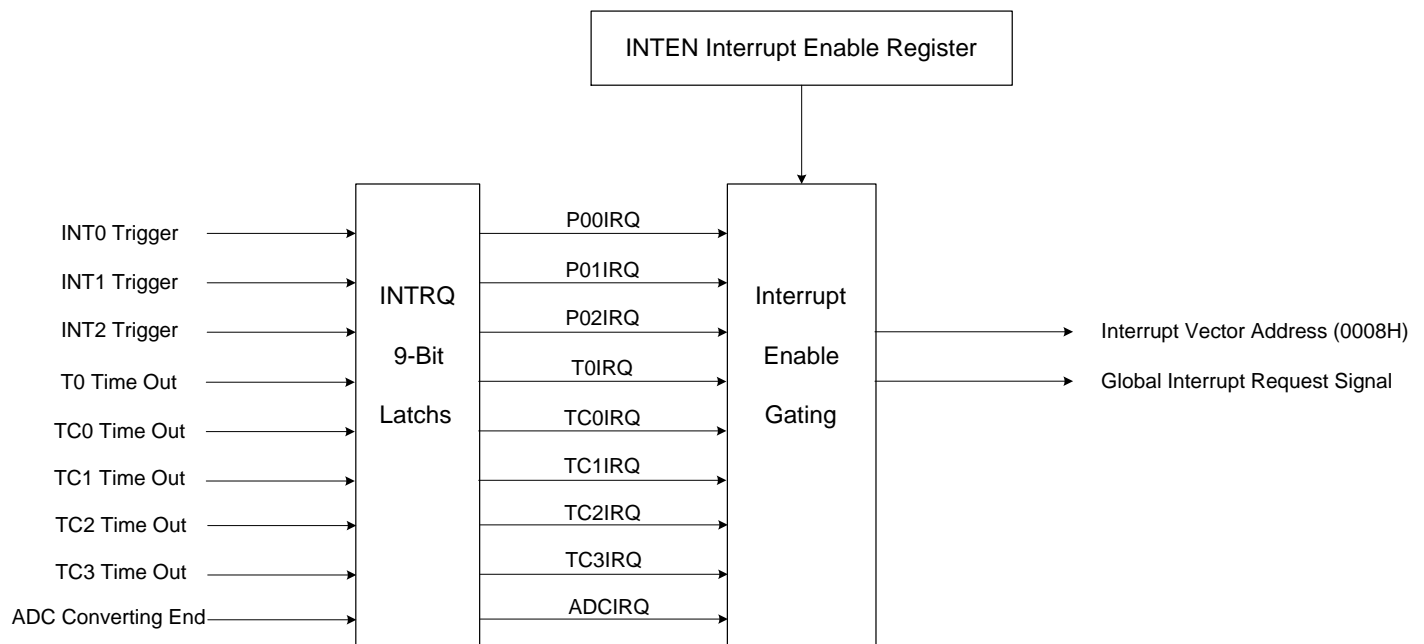

* **Note: The GIE bit must enable during all interrupt operation.**

6.2 INTEN INTERRUPT ENABLE REGISTER

INTEN0, INTEN1 are the interrupt request control register including six internal interrupts, three external interrupts enable control bits. One of the register to be set “1” is to enable the interrupt request function. Once of the interrupt occur, the stack is incremented and program jump to ORG 8 to execute interrupt service routines. The program exits the interrupt service routine when the returning interrupt service routine instruction (RETI) is executed.

0C9H	Bit 7	Bit 6	Bit 5	Bit 4	Bit 3	Bit 2	Bit 1	Bit 0
INTEN0	ADCIEN	TC1IEN	TC0IEN	TOIEN	-	P42IEN	P41IEN	P40IEN
Read/Write	R/W	R/W	R/W	R/W	-	R/W	R/W	R/W
After reset	0	0	0	0	-	0	0	0

Bit 0 **P40IEN:** External P4.0 interrupt (INT0) control bit.
0 = Disable INT0 interrupt function.
1 = Enable INT0 interrupt function.

Bit 1 **P41IEN:** External P4.1 interrupt (INT1) control bit.
0 = Disable INT1 interrupt function.
1 = Enable INT1 interrupt function.

Bit 2 **P42IEN:** External P4.2 interrupt (INT2) control bit.
0 = Disable INT2 interrupt function.
1 = Enable INT2 interrupt function.

Bit 4 **TOIEN:** T0 timer interrupt control bit.
0 = Disable T0 interrupt function.
1 = Enable T0 interrupt function.

Bit 5 **TC0IEN:** TC0 timer interrupt control bit.
0 = Disable TC0 interrupt function.
1 = Enable TC0 interrupt function.

Bit 6 **TC1IEN:** TC1 timer interrupt control bit.
0 = Disable TC1 interrupt function.
1 = Enable TC1 interrupt function.

Bit 7 **ADCIEN:** ADC interrupt control bit.
0 = Disable ADC interrupt function.
1 = Enable ADC interrupt function.

0C7H	Bit 7	Bit 6	Bit 5	Bit 4	Bit 3	Bit 2	Bit 1	Bit 0
INTEN1	-	-	-	-	-	-	TC3IEN	TC2IEN
Read/Write	-	-	-	-	-	-	R/W	R/W
After reset	-	-	-	-	-	-	0	0

Bit 0 **TC2IEN:** TC2 timer interrupt control bit.
0 = Disable TC2 interrupt function.
1 = Enable TC2 interrupt function.

Bit 1 **TC3IEN:** TC3 timer interrupt control bit.
0 = Disable TC3 interrupt function.
1 = Enable TC3 interrupt function.

6.3 INTRQ INTERRUPT REQUEST REGISTER

INTRQ0, INTRQ1 are the interrupt request flag register. The register includes all interrupt request indication flags. Each one of the interrupt request occurs, the bit of the INTRQ register would be set “1”. The INTRQ value needs to be clear by programming after detecting the flag. In the interrupt vector of program, users know the any interrupt requests occurring by the register and do the routine corresponding of the interrupt request.

0C8H	Bit 7	Bit 6	Bit 5	Bit 4	Bit 3	Bit 2	Bit 1	Bit 0
INTRQ0	ADCIRQ	TC1IRQ	TC0IRQ	T0IRQ	-	P42IRQ	P41IRQ	P40IRQ
Read/Write	R/W	R/W	R/W	R/W	-	R/W	R/W	R/W
After reset	0	0	0	0	-	0	0	0

Bit 0 **P40IRQ**: External P4.0 interrupt (INT0) request flag.
0 = None INT0 interrupt request.
1 = INT0 interrupt request.

Bit 1 **P41IRQ**: External P4.1 interrupt (INT1) request flag.
0 = None INT1 interrupt request.
1 = INT1 interrupt request.

Bit 2 **P42IRQ**: External P4.2 interrupt (INT2) request flag.
0 = None INT2 interrupt request.
1 = INT2 interrupt request.

Bit 4 **T0IRQ**: T0 timer interrupt request flag.
0 = None T0 interrupt request.
1 = T0 interrupt request.

Bit 5 **TC0IRQ**: TC0 timer interrupt request flag.
0 = None TC0 interrupt request.
1 = TC0 interrupt request.

Bit 6 **TC1IRQ**: TC1 timer interrupt request flag.
0 = None TC1 interrupt request.
1 = TC1 interrupt request.

Bit 7 **ADCIRQ**: ADC interrupt request flag.
0 = None ADC interrupt request.
1 = ADC interrupt request.

0C6H	Bit 7	Bit 6	Bit 5	Bit 4	Bit 3	Bit 2	Bit 1	Bit 0
INTRQ1	-	-	-	-	-	-	TC3IRQ	TC2IRQ
Read/Write	-	-	-	-	-	-	R/W	R/W
After reset	-	-	-	-	-	-	0	0

Bit 0 **TC2IRQ**: TC2 timer interrupt request flag.
0 = None TC2 interrupt request.
1 = TC2 interrupt request.

Bit 1 **TC3IRQ**: TC3 timer interrupt request flag.
0 = None TC3 interrupt request.
1 = TC3 interrupt request.

6.4 GIE GLOBAL INTERRUPT OPERATION

GIE is the global interrupt control bit. All interrupts start work after the GIE = 1 It is necessary for interrupt service request. One of the interrupt requests occurs, and the program counter (PC) points to the interrupt vector (ORG 8) and the stack add 1 level.

ODFH	Bit 7	Bit 6	Bit 5	Bit 4	Bit 3	Bit 2	Bit 1	Bit 0
STKP	GIE	-	-	-	-	STKPB2	STKPB1	STKPB0
Read/Write	R/W	-	-	-	-	R/W	R/W	R/W
After reset	0	-	-	-	-	1	1	1

Bit 7 **GIE:** Global interrupt control bit.
0 = Disable global interrupt.
1 = Enable global interrupt.

➤ **Example: Set global interrupt control bit (GIE).**

```
BOBSET      FGIE                      ; Enable GIE
```

* **Note: The GIE bit must enable during all interrupt operation.**

6.5 EXTERNAL INTERRUPT OPERATION (INT0~INT2)

Sonix provides 3 sets external interrupt sources in the micro-controller. INT0, INT1 and INT2 are external interrupt trigger sources and build in edge trigger configuration function. When the external edge trigger occurs, the external interrupt request flag will be set to "1" when the external interrupt control bit enabled. If the external interrupt control bit is disabled, the external interrupt request flag won't active when external edge trigger occurrence. When external interrupt control bit is enabled and external interrupt edge trigger is occurring, the program counter will jump to the interrupt vector (ORG 8) and execute interrupt service routine.

The external interrupt builds in wake-up latch function. That means when the system is triggered wake-up from power down or green mode, the wake-up source is external interrupt source (P4.0, P4.1 or P4.2), and the trigger edge direction matches interrupt edge configuration, the trigger edge will be latched, and the system executes interrupt service routine fist after wake-up.

0BFH	Bit 7	Bit 6	Bit 5	Bit 4	Bit 3	Bit 2	Bit 1	Bit 0
PEDGE	-	-	P42G1	P42G0	P41G1	P41G0	P40G1	P40G0
Read/Write	-	-	R/W	R/W	R/W	R/W	R/W	R/W
After reset	-	-	0	0	0	0	0	0

Bit[5:4] **P42G[1:0]**: INT2 edge trigger select bits.
00 = reserved,
01 = rising edge,
10 = falling edge,
11 = rising/falling bi-direction.

Bit[3:2] **P41G[1:0]**: INT1 edge trigger select bits.
00 = reserved,
01 = rising edge,
10 = falling edge,
11 = rising/falling bi-direction.

Bit[1:0] **P40G[1:0]**: INT0 edge trigger select bits.
00 = reserved,
01 = rising edge,
10 = falling edge,
11 = rising/falling bi-direction.

➤ **Example: Setup INT0 interrupt request and bi-direction edge trigger.**

```
MOV      A, #03H
BOMOV   PEDGE, A      ; Set INT0 interrupt trigger as bi-direction edge.

BOBSET  FP40IEN      ; Enable INT0 interrupt service
BOBCLR  FP40IRQ      ; Clear INT0 interrupt request flag
BOBSET  FGIE         ; Enable GIE
```

➤ **Example: INT0 interrupt service routine.**

```
ORG      8            ; Interrupt vector
JMP     INT_SERVICE

INT_SERVICE:
...
; Saving ACC and PFLAG to buffers executed by
; hardware automatically.

BOBTS1  FP40IRQ      ; Check P40IRQ
JMP     EXIT_INT     ; P40IRQ = 0, exit interrupt vector

BOBCLR  FP40IRQ      ; Reset P40IRQ
...
; INT1 interrupt service routine

EXIT_INT:
...
; Loading ACC and PFLAG from buffers executed by
; hardware automatically

RETI    ; Exit interrupt vector
```

➤ **Example: Setup INT1 interrupt request and bi-direction edge trigger.**

```

MOV      A, #0CH
B0MOV   PEDGE, A      ; Set INT1 interrupt trigger as bi-direction edge.

B0BSET  FP41IEN      ; Enable INT1 interrupt service
B0BCLR  FP41IRQ      ; Clear INT1 interrupt request flag
B0BSET  FGIE         ; Enable GIE

```

➤ **Example: INT1 interrupt service routine.**

```

ORG      8            ; Interrupt vector
JMP     INT_SERVICE

INT_SERVICE:
...
; Saving ACC and PFLAG to buffers executed by
; hardware automatically.

B0BTS1  FP41IRQ      ; Check P41IRQ
JMP     EXIT_INT     ; P41IRQ = 0, exit interrupt vector

B0BCLR  FP41IRQ      ; Reset P41IRQ
...
; INT1 interrupt service routine

EXIT_INT:
...
; Loading ACC and PFLAG from buffers executed by
; hardware automatically

RETI    ; Exit interrupt vector

```

➤ **Example: Setup INT2 interrupt request and bi-direction edge trigger.**

```

MOV      A, #30H
B0MOV   PEDGE, A      ; Set INT2 interrupt trigger as bi-direction edge.

B0BSET  FP42IEN      ; Enable INT2 interrupt service
B0BCLR  FP42IRQ      ; Clear INT2 interrupt request flag
B0BSET  FGIE         ; Enable GIE

```

➤ **Example: INT2 interrupt service routine.**

```

ORG      8            ; Interrupt vector
JMP     INT_SERVICE

INT_SERVICE:
...
; Saving ACC and PFLAG to buffers executed by
; hardware automatically.

B0BTS1  FP42IRQ      ; Check P42IRQ
JMP     EXIT_INT     ; P42IRQ = 0, exit interrupt vector

B0BCLR  FP42IRQ      ; Reset P42IRQ
...
; INT2 interrupt service routine

EXIT_INT:
...
; Loading ACC and PFLAG from buffers executed by
; hardware automatically

RETI    ; Exit interrupt vector

```

6.6 T0 INTERRUPT OPERATION

When the T0C counter occurs overflow, the T0IRQ will be set to "1" however the T0IEN is enable or disable. If the T0IEN = 1, the trigger event will make the T0IRQ to be "1" and the system enter interrupt vector. If the T0IEN = 0, the trigger event will make the T0IRQ to be "1" but the system will not enter interrupt vector. Users need to care for the operation under multi-interrupt situation.

➤ **Example: T0 interrupt request setup. Fcpu = 4MHz / 4.**

```

B0BCLR    FT0IEN    ; Disable T0 interrupt service
B0BCLR    FT0ENB    ; Disable T0 timer
MOV       A, #50H    ;
B0MOV     T0M, A     ; Set T0 clock = Fosc / 4
MOV       A, #9CH    ; Set T0C initial value = 9CH
B0MOV     T0C, A     ; Set T0 interval = 100 us

B0BSET    FT0IEN    ; Enable T0 interrupt service
B0BCLR    FT0IRQ    ; Clear T0 interrupt request flag
B0BSET    FT0ENB    ; Enable T0 timer

B0BSET    FGIE      ; Enable GIE

```

➤ **Example: T0 interrupt service routine.**

```

INT_SERVICE:
ORG       8          ; Interrupt vector
JMP      INT_SERVICE

...
; Saving ACC and PFLAG to buffers executed by
; hardware automatically.

B0BTS1   FT0IRQ     ; Check T0IRQ
JMP      EXIT_INT   ; T0IRQ = 0, exit interrupt vector

B0BCLR   FT0IRQ     ; Reset T0IRQ
MOV      A, #9CH    ;
B0MOV    T0C, A     ; Reset T0C.
...
; T0 interrupt service routine

EXIT_INT:
...
; Loading ACC and PFLAG from buffers executed by
; hardware automatically

RETI     ; Exit interrupt vector

```

6.7 TC0 INTERRUPT OPERATION

When the TC0C counter overflows, the TC0IRQ will be set to "1" no matter the TC0IEN is enable or disable. If the TC0IEN and the trigger event TC0IRQ is set to be "1". As the result, the system will execute the interrupt vector. If the TC0IEN = 0, the trigger event TC0IRQ is still set to be "1". Moreover, the system won't execute interrupt vector even when the TC0IEN is set to be "1". Users need to be cautious with the operation under multi-interrupt situation.

➤ **Example: TC0 interrupt request setup. Fosc = 4MHz / 4.**

```

B0BCLR      FTC0IEN      ; Disable TC0 interrupt service
B0BCLR      FTC0ENB      ; Disable TC0 timer
MOV         A, #50H      ;
B0MOV       TC0M, A      ; Set TC0 clock = Fosc / 4
MOV         A, #9CH      ; Set TC0C initial value = 9CH
B0MOV       TC0C, A      ; Set TC0 interval = 100 us
B0MOV       TC0R, A      ; Set TC0 reload buffer.

B0BSET      FTC0IEN      ; Enable TC0 interrupt service
B0BCLR      FTC0IRQ      ; Clear TC0 interrupt request flag
B0BSET      FTC0ENB      ; Enable TC0 timer

B0BSET      FGIE         ; Enable GIE

```

➤ **Example: TC0 interrupt service routine.**

```

INT_SERVICE:
ORG         8             ; Interrupt vector
JMP        INT_SERVICE

...

; Saving ACC and PFLAG to buffers executed by
; hardware automatically.

B0BTS1     FTC0IRQ      ; Check TC0IRQ
JMP        EXIT_INT     ; TC0IRQ = 0, exit interrupt vector

B0BCLR     FTC0IRQ      ; Reset TC0IRQ
...
; TC0 interrupt service routine
...

EXIT_INT:
...

; Loading ACC and PFLAG from buffers executed by
; hardware automatically

RETI      ; Exit interrupt vector

```

6.8 TC1 INTERRUPT OPERATION

When the TC1C counter overflows, the TC1IRQ will be set to "1" no matter the TC1IEN is enable or disable. If the TC1IEN and the trigger event TC1IRQ is set to be "1". As the result, the system will execute the interrupt vector. If the TC1IEN = 0, the trigger event TC1IRQ is still set to be "1". Moreover, the system won't execute interrupt vector even when the TC1IEN is set to be "1". Users need to be cautious with the operation under multi-interrupt situation.

➤ **Example: TC1 interrupt request setup. Fosc = 4MHz / 4.**

```

B0BCLR    FTC1IEN    ; Disable TC1 interrupt service
B0BCLR    FTC1ENB    ; Disable TC1 timer
MOV       A, #50H    ;
B0MOV     TC1M, A    ; Set TC1 clock = Fosc / 4
MOV       A, #9CH    ; Set TC1C initial value = 9CH
B0MOV     TC1C, A    ; Set TC1 interval = 100 us
B0MOV     TC1R, A    ; Set TC1 reload buffer.

B0BSET    FTC1IEN    ; Enable TC1 interrupt service
B0BCLR    FTC1IRQ    ; Clear TC1 interrupt request flag
B0BSET    FTC1ENB    ; Enable TC1 timer

B0BSET    FGIE       ; Enable GIE

```

➤ **Example: TC1 interrupt service routine.**

```

INT_SERVICE:
    ORG     8          ; Interrupt vector
    JMP     INT_SERVICE

    ...              ; Saving ACC and PFLAG to buffers executed by
                    ; hardware automatically.

    B0BTS1  FTC1IRQ    ; Check TC1IRQ
    JMP     EXIT_INT   ; TC1IRQ = 0, exit interrupt vector

    B0BCLR  FTC1IRQ    ; Reset TC1IRQ
    ...    ; TC1 interrupt service routine
    ...

EXIT_INT:
    ...              ; Loading ACC and PFLAG from buffers executed by
                    ; hardware automatically

    RETI           ; Exit interrupt vector

```

6.9 TC2 INTERRUPT OPERATION

When the TC2C counter overflows, the TC2IRQ will be set to "1" no matter the TC2IEN is enable or disable. If the TC2IEN and the trigger event TC2IRQ is set to be "1". As the result, the system will execute the interrupt vector. If the TC2IEN = 0, the trigger event TC2IRQ is still set to be "1". Moreover, the system won't execute interrupt vector even when the TC2IEN is set to be "1". Users need to be cautious with the operation under multi-interrupt situation.

➤ **Example: TC2 interrupt request setup. Fosc = 4MHz / 4.**

```

B0BCLR    FTC2IEN    ; Disable TC2 interrupt service
B0BCLR    FTC2ENB    ; Disable TC2 timer
MOV       A, #50H    ;
B0MOV     TC2M, A    ; Set TC2 clock = Fosc / 4
MOV       A, #9CH    ; Set TC2C initial value = 9CH
B0MOV     TC2C, A    ; Set TC2 interval = 100 us
B0MOV     TC2R, A    ; Set TC2 reload buffer.

B0BSET    FTC2IEN    ; Enable TC2 interrupt service
B0BCLR    FTC2IRQ    ; Clear TC2 interrupt request flag
B0BSET    FTC2ENB    ; Enable TC2 timer

B0BSET    FGIE       ; Enable GIE

```

➤ **Example: TC2 interrupt service routine.**

```

ORG       8          ; Interrupt vector
INT_SERVICE:
JMP       INT_SERVICE

...

; Saving ACC and PFLAG to buffers executed by
; hardware automatically.

B0BTS1    FTC2IRQ    ; Check TC2IRQ
JMP       EXIT_INT   ; TC2IRQ = 0, exit interrupt vector

B0BCLR    FTC2IRQ    ; Reset TC2IRQ
...
; TC2 interrupt service routine
...

EXIT_INT:
...

; Loading ACC and PFLAG from buffers executed by
; hardware automatically

RETI     ; Exit interrupt vector

```

6.10 TC3 INTERRUPT OPERATION

When the TC3C counter overflows, the TC3IRQ will be set to "1" no matter the TC3IEN is enable or disable. If the TC3IEN and the trigger event TC3IRQ is set to be "1". As the result, the system will execute the interrupt vector. If the TC3IEN = 0, the trigger event TC3IRQ is still set to be "1". Moreover, the system won't execute interrupt vector even when the TC3IEN is set to be "1". Users need to be cautious with the operation under multi-interrupt situation.

➤ **Example: TC3 interrupt request setup. Fosc = 4MHz / 4.**

```

B0BCLR    FTC3IEN    ; Disable TC3 interrupt service
B0BCLR    FTC3ENB    ; Disable TC3 timer
MOV       A, #50H    ;
B0MOV     TC3M, A    ; Set TC3 clock = Fosc / 4
MOV       A, #9CH    ; Set TC3C initial value = 9CH
B0MOV     TC3C, A    ; Set TC3 interval = 100 us
B0MOV     TC3R, A    ; Set TC3 reload buffer.

B0BSET    FTC3IEN    ; Enable TC3 interrupt service
B0BCLR    FTC3IRQ    ; Clear TC3 interrupt request flag
B0BSET    FTC3ENB    ; Enable TC3 timer

B0BSET    FGIE       ; Enable GIE

```

➤ **Example: TC3 interrupt service routine.**

```

INT_SERVICE:
    ORG     8          ; Interrupt vector
    JMP     INT_SERVICE

    ...

    ; Saving ACC and PFLAG to buffers executed by
    ; hardware automatically.

    B0BTS1  FTC3IRQ    ; Check TC3IRQ
    JMP     EXIT_INT   ; TC3IRQ = 0, exit interrupt vector

    B0BCLR  FTC3IRQ    ; Reset TC3IRQ
    ...
    ...
    ; TC3 interrupt service routine

EXIT_INT:
    ...

    ; Loading ACC and PFLAG from buffers executed by
    ; hardware automatically

    RETI          ; Exit interrupt vector

```

6.11 MULTI-INTERRUPT OPERATION

Under certain condition, the software designer uses more than one interrupt requests. Processing multi-interrupt request requires setting the priority of the interrupt requests. The IRQ flags of interrupts are controlled by the interrupt event. Nevertheless, the IRQ flag "1" doesn't mean the system will execute the interrupt vector. In addition, which means the IRQ flags can be set "1" by the events without enable the interrupt. Once the event occurs, the IRQ will be logic "1". The IRQ and its trigger event relationship is as the below table.

<i>Interrupt Name</i>	<i>Trigger Event Description</i>
P40IRQ	P4.0 trigger controlled by PEDGE.
P41IRQ	P4.1 trigger controlled by PEDGE.
P42IRQ	P4.2 trigger controlled by PEDGE.
T0IRQ	T0C overflow.
TC0IRQ	TC0C overflow.
TC1IRQ	TC1C overflow.
TC2IRQ	TC2C overflow.
TC3IRQ	TC3C overflow.
ADCIRQ	ADC converting end.

For multi-interrupt conditions, two things need to be taking care of. One is to set the priority for these interrupt requests. Two is using IEN and IRQ flags to decide which interrupt to be executed. Users have to check interrupt control bit and interrupt request flag in interrupt routine.

➤ Example: Check the interrupt request under multi-interrupt operation

```

        ORG          8          ; Interrupt vector
        JMP          INT_SERVICE

INT_SERVICE:

        ...                ; Saving ACC and PFLAG to buffers executed by
                           ; hardware automatically.

INTP40CHK:                ; Check INT0 interrupt request
        B0BTS1        FP40IEN ; Check P40IEN
        JMP          INTP41CHK ; Jump check to next interrupt
        B0BTS0        FP40IRQ ; Check P40IRQ
        JMP          INTP40    ; Jump to INT0 interrupt service routine

INTP41CHK:                ; Check INT1 interrupt request
        B0BTS1        FP41IEN ; Check P41IEN
        JMP          INTP42CHK ; Jump check to next interrupt
        B0BTS0        FP41IRQ ; Check P41IRQ
        JMP          INTP41    ; Jump to INT1 interrupt service routine

INTP42CHK:                ; Check INT2 interrupt request
        B0BTS1        FP42IEN ; Check P42IEN
        JMP          INTT0CHK  ; Jump check to next interrupt
        B0BTS0        FP42IRQ ; Check P42IRQ
        JMP          INTP42    ; Jump to INT2 interrupt service routine

INTT0CHK:                 ; Check T0 interrupt request
        B0BTS1        FT0IEN  ; Check T0IEN
        JMP          INTTC0CHK ; Jump check to next interrupt
        B0BTS0        FT0IRQ  ; Check T0IRQ
        JMP          INTT0     ; Jump to T0 interrupt service routine

INTTC0CHK:                ; Check TC0 interrupt request
        B0BTS1        FTC0IEN ; Check TC0IEN
        JMP          INTTC1CHK ; Jump check to next interrupt
        B0BTS0        FTC0IRQ ; Check TC0IRQ
        JMP          INTTC0    ; Jump to TC0 interrupt service routine

INTTC1CHK:                ; Check TC1 interrupt request
        B0BTS1        FTC1IEN ; Check TC1IEN
        JMP          INTTC2CHK ; Jump to exit of IRQ

```

```

      B0BTS0      FTC1IRQ      ; Check TC1IRQ
      JMP          INTTC1      ; Jump to TC1 interrupt service routine
INTTC2CHK:      ; Check TC2 interrupt request
      B0BTS1      FTC2IEN      ; Check TC2IEN
      JMP          INTTC3CHK    ; Jump check to next interrupt
      B0BTS0      FTC2IRQ      ; Check TC2IRQ
      JMP          INTTC2      ; Jump to TC2 interrupt service routine
INTTC3CHK:      ; Check TC3 interrupt request
      B0BTS1      FTC3IEN      ; Check TC3IEN
      JMP          INTADCCHK    ; Jump to exit of IRQ
      B0BTS0      FTC3IRQ      ; Check TC3RQ
      JMP          INTTC3      ; Jump to TC3 interrupt service routine
INTADCCHK:      ; Check ADC interrupt request
      B0BTS1      FADCIEN      ; Check ADCIEN
      JMP          INT_EXIT     ; Jump to exit of IRQ
      B0BTS0      FADCIRQ      ; Check ADCIRQ
      JMP          INTADC      ; Jump to ADC interrupt service routine
INT_EXIT:
      ...
      ; Loading ACC and PFLAG from buffers executed by
      ; hardware automatically

      RETI                ; Exit interrupt vector

```

7 I/O PORT

7.1 OVERVIEW

The micro-controller builds in 18 pin I/O. Most of the I/O pins are mixed with analog pins and special function pins. The I/O shared pin list is as following.

I/O Pin		Shared Pin		Shared Pin Control Condition
Name	Type	Name	Type	
P4.0	I/O	INT0	DC	P40IEN=1
		AIN[0]	AC	ADENB=1,GCHS=1,CHS[3:0]=0000b
		AVREFH	AC	EVHENB =1
P4.1	I/O	INT1	DC	P41IEN=1
		AIN[1]	AC	ADENB=1,GCHS=1,CHS[3:0]=0001b
P4.2	I/O	INT2	DC	P42IEN=1
		AIN[2]	AC	ADENB=1,GCHS=1,CHS[3:0]=0010b
P4.3	I/O	AIN[3]	AC	ADENB=1,GCHS=1,CHS[3:0]=0011b
P4.4	I/O	AIN[4]	AC	ADENB=1,GCHS=1,CHS[3:0]=0100b
P4.5	I/O	AIN[5]	AC	ADENB=1,GCHS=1,CHS[3:0]=0101b
P4.6	I/O	PWM0	DC	TC0ENB=1, PWM0OUT=1
		AIN[6]	AC	ADENB=1,GCHS=1,CHS[3:0]=0110b
P4.7	I/O	AIN[7]	AC	ADENB=1,GCHS=1,CHS[3:0]=0111b
P2.0	I/O	PWM20	DC	TC2ENB=1, PWM2OUT=1, PWCH20=1
		AIN[9]	AC	ADENB=1,GCHS=1,CHS[3:0]=1001b
P2.1	I/O	PWM30	DC	TC3ENB=1, PWM3OUT=1, PWCH30=1
		AIN[8]	AC	ADENB=1,GCHS=1,CHS[3:0]=1000b
P1.2	I/O	RST	DC	Reset_Pin code option = Reset
		VPP	HV	OTP Programming
P1.0	I/O	XIN	AC	High_CLK code option = IHRC_RTC, RC, 32K, 4M, 12M
P1.1	I/O	XOUT	AC	High_CLK code option = IHRC_RTC, 32K, 4M, 12M
P1.3	I/O	PWM11	DC	TC1ENB=1, PWM1OUT=1, PWCH11=1
P1.4	I/O	PWM21	DC	TC2ENB=1, PWM2OUT=1, PWCH21=1
P1.5	I/O	PWM31	DC	TC3ENB=1, PWM3OUT=1, PWCH31=1
P1.6	I/O	AIN[11]	AC	ADENB=1,GCHS=1,CHS[3:0]=1011b
P1.7	I/O	PWM10	DC	TC1ENB=1, PWM1OUT=1, PWCH10=1
		AIN[10]	AC	ADENB=1,GCHS=1,CHS[3:0]=1010b

* DC: Digital Characteristic. AC: Analog Characteristic. HV: High Voltage Characteristic.

7.2 I/O PORT MODE

The port direction is programmed by PnM register. When the bit of PnM register is “0”, the pin is input mode. When the bit of PnM register is “1”, the pin is output mode.

0C1H	Bit 7	Bit 6	Bit 5	Bit 4	Bit 3	Bit 2	Bit 1	Bit 0
P1M	P17M	P16M	P15M	P14M	P13M	P12M	P11M	P10M
Read/Write	R/W	R/W	R/W	R/W	R/W	R/W	R/W	R/W
After reset	0	0	0	0	0	0	0	0

0C2H	Bit 7	Bit 6	Bit 5	Bit 4	Bit 3	Bit 2	Bit 1	Bit 0
P2M	-	-	-	-	-	-	P21M	P20M
Read/Write	-	-	-	-	-	-	R/W	R/W
After reset	-	-	-	-	-	-	0	0

0C4H	Bit 7	Bit 6	Bit 5	Bit 4	Bit 3	Bit 2	Bit 1	Bit 0
P4M	P47M	P46M	P45M	P44M	P43M	P42M	P41M	P40M
Read/Write	R/W	R/W	R/W	R/W	R/W	R/W	R/W	R/W
After reset	0	0	0	0	0	0	0	0

Bit[7:0] **PnM[7:0]**: Pn mode control bits. (n = 0~5).
 0 = Pn is input mode.
 1 = Pn is output mode.

*** Note: Users can program them by bit control instructions (B0BSET, B0BCLR).**

➤ **Example: I/O mode selecting**

```

CLR          P1M          ; Set all ports to be input mode.
CLR          P2M
CLR          P4M

MOV          A, #0FFH    ; Set all ports to be output mode.
B0MOV       P1M, A
B0MOV       P2M, A
B0MOV       P4M, A

B0BCLR      P1M.0        ; Set P1.0 to be input mode.
B0BSET      P1M.0        ; Set P1.0 to be output mode.
    
```

7.3 I/O PULL UP REGISTER

The I/O pins build in internal pull-up resistors and only support I/O input mode. The port internal pull-up resistor is programmed by PnUR register. When the bit of PnUR register is “0”, the I/O pin’s pull-up is disabled. When the bit of PnUR register is “1”, the I/O pin’s pull-up is enabled.

0E1H	Bit 7	Bit 6	Bit 5	Bit 4	Bit 3	Bit 2	Bit 1	Bit 0
P1UR	P17R	P16R	P15R	P14R	P13R	-	P11R	P10R
Read/Write	W	W	W	W	W	-	W	W
After reset	0	0	0	0	0	-	0	0

0E2H	Bit 7	Bit 6	Bit 5	Bit 4	Bit 3	Bit 2	Bit 1	Bit 0
P2UR	-	-	-	-	-	-	P21R	P20R
Read/Write	-	-	-	-	-	-	W	W
After reset	-	-	-	-	-	-	0	0

0E4H	Bit 7	Bit 6	Bit 5	Bit 4	Bit 3	Bit 2	Bit 1	Bit 0
P4UR	P47R	P46R	P45R	P44R	P43R	P42R	P41R	P40R
Read/Write	W	W	W	W	W	W	W	W
After reset	0	0	0	0	0	0	0	0

* **Note: P1.2 is without pull-up resistor. The P1UR.2 is undefined.**

➤ Example: I/O Pull-up Register

```
MOV      A, #0FFH      ; Enable Port1, 2, 4 Pull-up register,
B0MOV    P1UR, A      ;
B0MOV    P2UR, A
B0MOV    P4UR, A
```

7.4 I/O PULL DOWN REGISTER

The P1.3~P1.6 I/O pins build in internal pull-down resistors and only support I/O input mode. The port internal pull-down resistor is programmed by P1DR register. When the bit of P1DR register is "0", the I/O pin's pull-down is disabled. When the bit of P1DR register is "1", the I/O pin's pull-down is enabled

0D6H	Bit 7	Bit 6	Bit 5	Bit 4	Bit 3	Bit 2	Bit 1	Bit 0
P1DR	P16SC	P15SC	P14SC	P13SC	P16DR	P15DR	P14DR	P13DR
Read/Write	W	W	W	W	W	W	W	W
After reset	0	0	0	0	0	0	0	0

Bit 3 **P16DR:** P1.6 I/O port pull-down resistor control bit.
0 = Disable P1.6 pull-down resistor.
1 = Enable P1.6 pull-down resistor.

Bit 2 **P15DR:** P1.5 I/O port pull-down resistor control bit.
0 = Disable P1.5 pull-down resistor.
1 = Enable P1.5 pull-down resistor.

Bit 1 **P14DR:** P1.4 I/O port pull-down resistor control bit.
0 = Disable P1.4 pull-down resistor.
1 = Enable P1.4 pull-down resistor.

Bit 0 **P13DR:** P1.3 I/O port pull-down resistor control bit.
0 = Disable P1.3 pull-down resistor.
1 = Enable P1.3 pull-down resistor.

➤ **Example: I/O Pull-down Register**

```
MOV      A, #0FH      ; Enable P1.3~P1.6 Pull-down register,
B0MOV    P1DR, A      ;
```

7.5 PORT1 I/O SCHMITT-TRIGGER REGISTER

The I/O pins build in internal Schmitt-trigger structure and only support I/O input mode. But the P1.3~P1.6 supports Schmitt-trigger control only. The P1.3~P1.6 Schmitt-trigger enable/disable is programmable by P1DR[7:4] register. When the bit of P1DR[7:4] register is "0", the I/O pin's Schmitt-trigger is enabled. When the bit of P1DR[7:4] register is "1", the I/O pin's Schmitt-trigger is disabled.

0D6H	Bit 7	Bit 6	Bit 5	Bit 4	Bit 3	Bit 2	Bit 1	Bit 0
P1DR	P16SC	P15SC	P14SC	P13SC	P16DR	P15DR	P14DR	P13DR
Read/Write	W	W	W	W	W	W	W	W
After reset	0	0	0	0	0	0	0	0

Bit 7 **P16SC**: P1.6 I/O port Schmitt-trigger control bit.
0 = Enable P1.6 Schmitt-trigger.
1 = Disable P1.6 Schmitt-trigger.

Bit 6 **P15SC**: P1.5 I/O port Schmitt-trigger control bit.
0 = Enable P1.5 Schmitt-trigger.
1 = Disable P1.5 Schmitt-trigger.

Bit 5 **P14SC**: P1.4 I/O port Schmitt-trigger control bit.
0 = Enable P1.4 Schmitt-trigger.
1 = Disable P1.4 Schmitt-trigger.

Bit 4 **P13SC**: P1.3 I/O port Schmitt-trigger control bit.
0 = Enable P1.3 Schmitt-trigger.
1 = Disable P1.3 Schmitt-trigger.

➤ **Example: P1.3~P1.6 Schmitt-trigger Register**

```
MOV      A, #0F0H      ; Disable P1.3~P1.6 Schmitt-trigger.,
B0MOV   P1DR, A      ;
```

* **Note: P1.3~P1.6 Schmitt trigger control for low power consumption under P1.3~P1.6 input half voltage.**

7.6 I/O PORT DATA REGISTER

0D1H	Bit 7	Bit 6	Bit 5	Bit 4	Bit 3	Bit 2	Bit 1	Bit 0
P1	P17	P16	P15	P14	P13	P12	P11	P10
Read/Write	R/W	R/W	R/W	R/W	R/W	R/W	R/W	R/W
After reset	0	0	0	0	0	0	0	0

0D2H	Bit 7	Bit 6	Bit 5	Bit 4	Bit 3	Bit 2	Bit 1	Bit 0
P2	-	-	-	-	-	-	P21	P20
Read/Write	-	-	-	-	-	-	R/W	R/W
After reset	-	-	-	-	-	-	0	0

0D4H	Bit 7	Bit 6	Bit 5	Bit 4	Bit 3	Bit 2	Bit 1	Bit 0
P4	P47	P46	P45	P44	P43	P42	P41	P40
Read/Write	R/W	R/W	R/W	R/W	R/W	R/W	R/W	R/W
After reset	0	0	0	0	0	0	0	0

* **Note:** The P12 keeps "1" and P12 as input mode, when external reset enable by code option.

➤ **Example: Read data from input port.**

```
B0MOV      A, P1           ; Read data from Port 1
B0MOV      A, P2           ; Read data from Port 2
B0MOV      A, P4           ; Read data from Port 4
```

➤ **Example: Write data to output port.**

```
MOV        A, #0FFH       ; Write data FFH to all Port.
B0MOV      P1, A
B0MOV      P2, A
B0MOV      P4, A
```

➤ **Example: Write one bit data to output port.**

```
B0BSET     P1.0           ; Set P1.0 and P1.3 to be "1".
B0BSET     P1.3

B0BCLR     P1.0           ; Set P1.0 and P1.3 to be "0".
B0BCLR     P1.3
```

8 TIMERS

8.1 WATCHDOG TIMER

The watchdog timer (WDT) is a binary up counter designed for monitoring program execution. If the program goes into the unknown status by noise interference, WDT overflow signal raises and resets MCU. Watchdog clock controlled by code option and the clock source is internal low-speed oscillator.

Watchdog overflow time = 8192 / Internal Low-Speed oscillator (sec).

VDD	Internal Low RC Freq.	Watchdog Overflow Time
3V	16KHz	512ms
5V	32KHz	256ms

The watchdog timer has three operating options controlled “WatchDog” code option.

- **Disable:** Disable watchdog timer function.
- **Enable:** Enable watchdog timer function. Watchdog timer activates in normal mode and slow mode. In power down mode and green mode, the watchdog timer stops.
- **Always_On:** Enable watchdog timer function. The watchdog timer activates and not stop in power down mode and green mode.

In high noisy environment, the “Always_On” option of watchdog operations is the strongly recommendation to make the system reset under error situations and re-start again.

Watchdog clear is controlled by WDTR register. Moving **0x5A** data into WDTR is to reset watchdog timer.

OCCH	Bit 7	Bit 6	Bit 5	Bit 4	Bit 3	Bit 2	Bit 1	Bit 0
WDTR	WDTR7	WDTR6	WDTR5	WDTR4	WDTR3	WDTR2	WDTR1	WDTR0
Read/Write	W	W	W	W	W	W	W	W
After reset	0	0	0	0	0	0	0	0

- **Example: An operation of watchdog timer is as following. To clear the watchdog timer counter in the top of the main routine of the program.**

```
Main:
      MOV      A, #5AH          ; Clear the watchdog timer.
      B0MOV   WDTR, A
      ...
      CALL    SUB1
      CALL    SUB2
      ...
      JMP     MAIN
```

- **Example: Clear watchdog timer by “@RST_WDT” macro of Sonix IDE.**

```
Main:
      @RST_WDT                ; Clear the watchdog timer.
      ...
      CALL    SUB1
      CALL    SUB2
      ...
      JMP     MAIN
```

Watchdog timer application note is as following.

- Before clearing watchdog timer, check I/O status and check RAM contents can improve system error.
 - Don't clear watchdog timer in interrupt vector and interrupt service routine. That can improve main routine fail.
 - Clearing watchdog timer program is only at one part of the program. This way is the best structure to enhance the watchdog timer function.
- **Example: An operation of watchdog timer is as following. To clear the watchdog timer counter in the top of the main routine of the program.**

Main:

```
... ; Check I/O.
... ; Check RAM
```

```
Err: JMP $ ; I/O or RAM error. Program jump here and don't
; clear watchdog. Wait watchdog timer overflow to reset IC.
```

Correct:

```
MOV A, #5AH ; I/O and RAM are correct. Clear watchdog timer and
B0MOV WDTR, A ; execute program.
; Clear the watchdog timer.
...
CALL SUB1
CALL SUB2
...
...
JMP MAIN
```

8.2 T0 8-BIT BASIC TIMER

8.2.1 OVERVIEW

The T0 timer is an 8-bit binary up timer with basic timer function. The basic timer function supports flag indicator (T0IRQ bit) and interrupt operation (interrupt vector). The interval time is programmable through T0M, T0C registers and supports RTC function. The T0 builds in green mode wake-up function. When T0 timer overflow occurs under green mode, the system will be waked-up to last operating mode.

The main purposes of the T0 timer are as following.

- ☞ **8-bit programmable up counting timer:** Generate time-out at specific time intervals based on the selected clock frequency.
- ☞ **Interrupt function:** T0 timer function supports interrupt function. When T0 timer occurs overflow, the T0IRQ actives and the system points program counter to interrupt vector to do interrupt sequence.
- ☞ **RTC function:** T0 supports RTC function. The RTC clock source is from external low speed 32K oscillator when T0TB=1. **RTC function is only available in High_Clk code option = "IHRC_RTC".**
- ☞ **Green mode function:** T0 timer keeps running in green mode and wakes up system when T0 timer overflows.

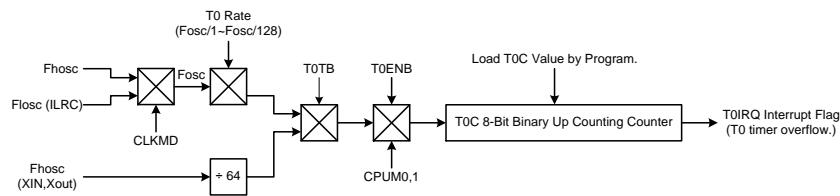

* **Note: In RTC mode, the T0 interval time is fixed at 0.5 sec and T0C is 256 counts.**

8.2.2 T0 Timer Operation

T0 timer is controlled by T0ENB bit. When T0ENB=0, T0 timer stops. When T0ENB=1, T0 timer starts to count. T0C increases “1” by timer clock source. When T0 overflow event occurs, T0IRQ flag is set as “1” to indicate overflow and cleared by program. The overflow condition is T0C count from full scale (0xFF) to zero scale (0x00). T0 doesn’t build in double buffer, so load T0C by program when T0 timer overflows to fix the correct interval time. If T0 timer interrupt function is enabled (T0IEN=1), the system will execute interrupt procedure. The interrupt procedure is system program counter points to interrupt vector (ORG 8) and executes interrupt service routine after T0 overflow occurrence. Clear T0IRQ by program is necessary in interrupt procedure. T0 timer can works in normal mode, slow mode and green mode. In green mode, T0 keeps counting, set T0IRQ and wakes up system when T0 timer overflows.

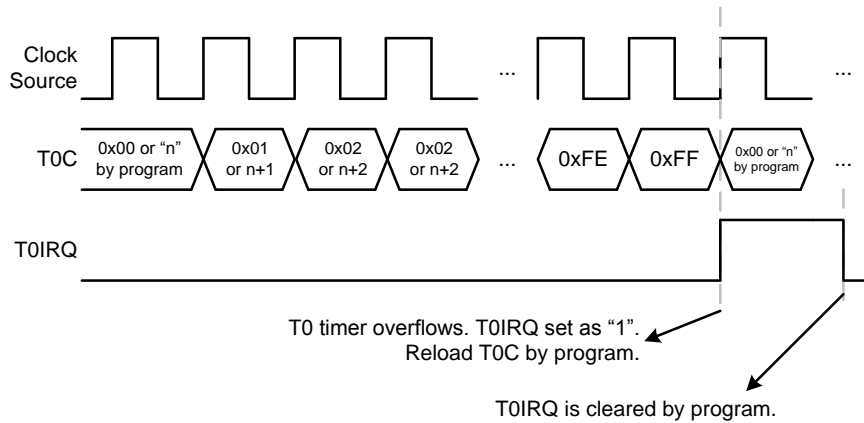

T0 timer clock sources are Fosc (Fhosc and Fosc) and RTC (external oscillator, T0TB=1) through T0rate[2:0] pre-scaler to decide Fosc/1~Fosc/128. Setting CLKMD=0, T0 clock source is Fosc through T0rate[2:0] pre-scaler. Setting CLKMD=1, T0 clock source is Fosc (ILRC) through T0rate[2:0] pre-scaler. T0 length is 8-bit (256 steps), and the one count period is each cycle of input clock.

T0rate[2:0]	T0 Clock	T0 Interval Time					
		Fhosc=16MHz, CLKMD = 0		Fosc=32KHz@5V, CLKMD = 1		IHRC_RTC mode	
		max. (us)	Unit (us)	max. (ms)	Unit (ms)	max. (sec)	Unit (ms)
000b	Fosc/128	2048	8	1024	4	-	-
001b	Fosc/64	1024	4	512	2	-	-
010b	Fosc/32	512	2	256	1	-	-
011b	Fosc/16	256	1	128	0.5	-	-
100b	Fosc/8	128	0.5	64	0.25	-	-
101b	Fosc/4	64	0.25	32	0.125	-	-
110b	Fosc/2	32	0.125	16	0.0625	-	-
111b	Fosc/1	16	0.0625	8	0.03125	-	-
-	32768Hz/64	-	-	-	-	0.5	1.953

8.2.3 T0M MODE REGISTER

T0M is T0 timer mode control register to configure T0 operating mode including T0 pre-scaler, clock source. These configurations must be setup completely before enabling T0 timer.

0D8H	Bit 7	Bit 6	Bit 5	Bit 4	Bit 3	Bit 2	Bit 1	Bit 0
T0M	T0ENB	T0rate2	T0rate1	T0rate0	-	-	-	T0TB
Read/Write	R/W	R/W	R/W	R/W	-	-	-	R/W
After reset	0	0	0	0	-	-	-	0

Bit 0 **T0TB**: RTC clock source control bit.
0 = Disable RTC (T0 clock source from Fosc).
1 = Enable RTC.

Bit [6:4] **T0RATE[2:0]**: T0 timer clock source select bits.
000 = Fosc/128, 001 = Fosc/64, 010 = Fosc/32, 011 = Fosc/16, 100 = Fosc/8, 101 = Fosc/4, 110 = Fosc/2, 111 = Fosc/1.

Bit 7 **T0ENB**: T0 counter control bit.
0 = Disable T0 timer.
1 = Enable T0 timer.

* **Note: T0RATE is not available in RTC mode. The T0 interval time is fixed at 0.5 sec.**

8.2.4 T0C COUNTING REGISTER

T0C is T0 8-bit counter. When T0C overflow occurs, the T0IRQ flag is set as "1" and cleared by program. The T0C decides T0 interval time through below equation to calculate a correct value. It is necessary to write the correct value to T0C register, and then enable T0 timer to make sure the first cycle correct. After one T0 overflow occurs, the T0C register is loaded a correct value by program.

0D9H	Bit 7	Bit 6	Bit 5	Bit 4	Bit 3	Bit 2	Bit 1	Bit 0
T0C	T0C7	T0C6	T0C5	T0C4	T0C3	T0C2	T0C1	T0C0
Read/Write	R/W	R/W	R/W	R/W	R/W	R/W	R/W	R/W
After reset	0	0	0	0	0	0	0	0

The equation of T0C initial value is as following.

$$T0C \text{ initial value} = 256 - (T0 \text{ interrupt interval time} * T0 \text{ clock rate})$$

➤ **Example: To calculation T0C to obtain 100us T0 interval time. T0 clock source is Fosc = 4MHz. Select T0RATE=101 (Fosc/4).**

T0 interval time = 100us. T0 clock rate = 4MHz/4

$$\begin{aligned} T0C \text{ initial value} &= 256 - (T0 \text{ interval time} * \text{input clock}) \\ &= 256 - (100\mu\text{s} * 4\text{MHz} / 4) \\ &= 256 - (100 * 10^{-6} * 4 * 10^6 / 4) \\ &= 9\text{CH} \end{aligned}$$

* **Note: In RTC mode, T0C is 256 counts and generates T0 0.5 sec interval time. Don't change T0C value in RTC mode.**

8.2.5 T0 TIMER OPERATION EXPLAME

- **T0 TIMER CONFIGURATION:**

- ; **Reset T0 timer.**

```
MOV      A, #0x00      ; Clear T0M register.
B0MOV   T0M, A
```

- ; **Set T0 clock source and T0 rate.**

```
MOV      A, #0nnn0000b
B0MOV   T0M, A
```

- ; **Set T0C register for T0 Interval time.**

```
MOV      A, #value
B0MOV   T0C, A
```

- ; **Clear T0IRQ**

```
B0BCLR  FT0IRQ
```

- ; **Enable T0 timer and interrupt function.**

```
B0BSET  FT0IEN      ; Enable T0 interrupt function.
B0BSET  FT0ENB      ; Enable T0 timer.
```

- **T0 works in RTC mode:**

- ; **Reset T0 timer.**

```
MOV      A, #0x00      ; Clear T0M register.
B0MOV   T0M, A
```

- ; **Set T0 RTC function.**

```
B0BSET  FT0TB
```

- ; **Clear T0C.**

```
CLR     T0C
```

- ; **Clear T0IRQ**

```
B0BCLR  FT0IRQ
```

- ; **Enable T0 timer and interrupt function.**

```
B0BSET  FT0IEN      ; Enable T0 interrupt function.
B0BSET  FT0ENB      ; Enable T0 timer.
```



8.3 TC0 8-BIT TIMER/COUNTER

8.3.1 OVERVIEW

The TC0 timer is an 8-bit binary up timer and supports normal 8-bit timer, event counter, PWM, One Pulse PWM function. If TC0 timer occurs an overflow (from 0xFF to 0x00), it will continue counting and issue a time-out signal to indicate TC0 time out event. TC0 builds in event counter function. The clock source is from external input pin (P4.0) controlled by TC0CKS. When TC0CKS = 1, TC0 clock source is selected from P4.0 and enables event counter function. TC0 builds in PWM function. The PWM is duty/cycle programmable controlled by TC0R and TC0D registers. It is easy to implement buzzer, PWM and IR carry signal. TC0 PWM function also supports one pulse output signal that means only output one cycle PWM signal, not continuous. The enabled PWM channel exchanges from GPIO to PWM output. TC0 counter supports auto-reload function which always enabled. When TC0 timer overflow occurs, the TC0C will be reloaded from TC0R automatically. The auto-reload function is always enabled. The TC0 doesn't build in green mode wake-up function.

The main purposes of the TC0 timer are as following.

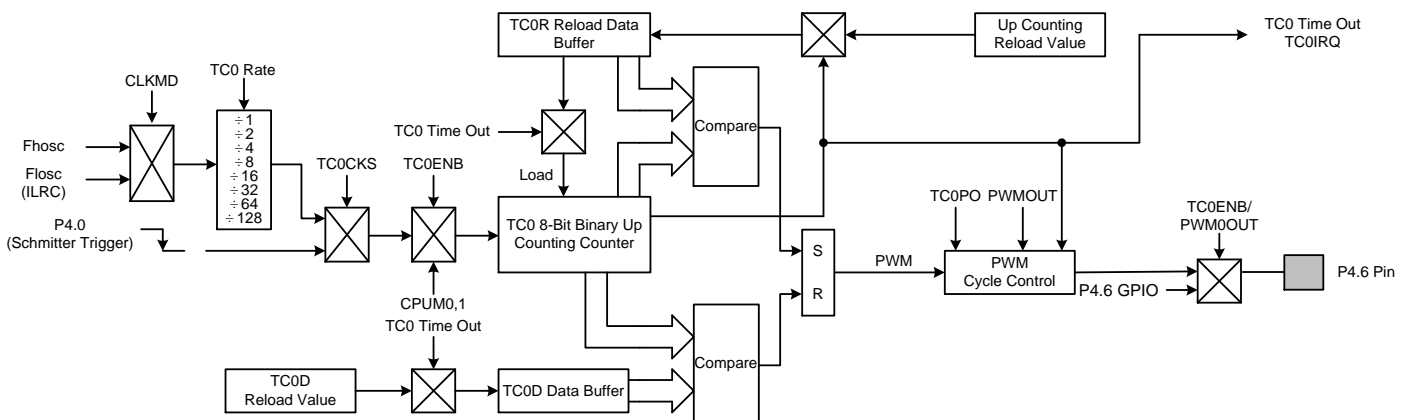
- ☞ **8-bit programmable up counting timer:** Generate time-out at specific time intervals based on the selected clock frequency.
- ☞ **Interrupt function:** TC0 timer function supports interrupt function. When TC0 timer occurs overflow, the TC0IRQ activates and the system points program counter to interrupt vector to do interrupt sequence.
- ☞ **Event Counter:** The event counter function counts the external clock counts.
- ☞ **Duty/cycle programmable PWM:** The PWM is duty/cycle programmable controlled by TC0R and TC0D registers.
- ☞ **One Pulse PWM:** The one pulse PWM is controlled by TC0PO bit. When TC0PO=0, TC0 is normal timer mode or PWM function mode. When TC0PO=1, TC0 is one pulse PWM function. When PWMOUT=1, one pulse PWM outputs and the TC0IRQ is issued as TC0 counter overflow, PWMOUT bit is cleared automatically, the PWM channel returns to GPIO mode and last status.
- ☞ **Green mode function:** All TC0 functions (timer, PWM, event counter, auto-reload, extension) keeps running in green mode, but no wake-up function. Timer IRQ activates as any IRQ trigger occurrence, e.g. timer overflow...



8.3.2 TC0 TIMER OPERATION

TC0 timer is controlled by TC0ENB bit. When TC0ENB=0, TC0 timer stops. When TC0ENB=1, TC0 timer starts to count. Before enabling TC0 timer, setup TC0 timer's configurations to select timer function modes, e.g. basic timer, interrupt function...TC0C increases "1" by timer clock source. When TC0 overflow event occurs, TC0IRQ flag is set as "1" to indicate overflow and cleared by program. The overflow condition is TC0C count from full scale (0xFF) to zero scale (0x00). In difference function modes, TC0C value relates to operation. If TC0C value changing effects operation, the transition of operations would make timer function error. So TC0 builds in double buffer to avoid these situations happen. The double buffer concept is to flash TC0C during TC0 counting, to set the new value to TC0R (reload buffer), and the new value will be loaded from TC0R to TC0C after TC0 overflow occurrence automatically. In the next cycle, the TC0 timer runs under new conditions, and no any transitions occur. The auto-reload function is no any control interface and always actives as TC0 enables. If TC0 timer interrupt function is enabled (TC0IEN=1), the system will execute interrupt procedure. The interrupt procedure is system program counter points to interrupt vector (ORG 0008H) and executes interrupt service routine after TC0 overflow occurrence. Clear TC0IRQ by program is necessary in interrupt procedure. TC0 timer can works in normal mode, slow mode and green mode. Under green mode, TC0 keep counting, set TC0IRQ and outputs PWM, can't wake-up system.

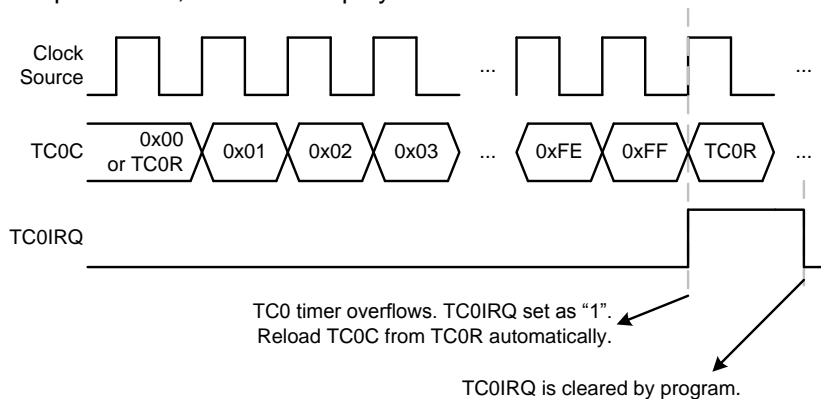

TC0 provides different clock sources to implement different applications and configurations. TC0 clock source includes Fosc (high speed oscillator), Fosc (low speed RC oscillator) and external input pin (P4.0) controlled by TC0CKS and FCLKMD bits. TC0CKS bit selects the clock source is from Fosc or P4.0. If TC0CKS=0 and FCLKMD=0, TC0 clock source is Fosc through TC0rate[2:0] pre-scalar to decide Fosc/1~Fosc/128. If TC0CKS=0 and FCLKMD=1, TC0 clock source is Fosc through TC0rate[2:0] pre-scalar to decide Fosc/1~Fosc/128. If TC0CKS=1, TC0 clock source is external input pin that means to enable event counter function. TC0rate[2:0] pre-scalar is unless when TC0CKS=1 condition. TC0 length is 8-bit (256 steps), and the one count period is each cycle of input clock.

CLKMD	TC0rate[2:0]	TC0 Clock	TC0 Interval Time			
			Fosc=16MHz, Fcpu=Fosc/4		Fosc=4MHz, Fcpu=Fosc/4	
			max. (us)	Unit (us)	max. (us)	Unit (us)
0	000b	Fosc/128	2048	8	8192	32
0	001b	Fosc/64	1024	4	4096	16
0	010b	Fosc/32	512	2	2048	8
0	011b	Fosc/16	256	1	1024	4
0	100b	Fosc/8	128	0.5	512	2
0	101b	Fosc/4	64	0.25	256	1
0	110b	Fosc/2	32	0.125	128	0.5
0	111b	Fosc/1	16	0.0625	64	0.25
CLKMD	TC0rate[2:0]	TC0 Clock	TC0 Interval Time			
			Fosc=32KHz, Fcpu=Fosc/4		Fosc=16KHz, Fcpu=Fosc/4	
			max. (ms)	Unit (ms)	max. (ms)	Unit (ms)
1	000b	Fosc/128	1024	4	2048	8
1	001b	Fosc/64	512	2	1024	4
1	010b	Fosc/32	256	1	512	2
1	011b	Fosc/16	128	0.5	256	1
1	100b	Fosc/8	64	0.25	128	0.5
1	101b	Fosc/4	32	0.125	64	0.25
1	110b	Fosc/2	16	0.0625	32	0.125
1	111b	Fosc/1	8	0.03125	16	0.0625

8.3.3 TC0M MODE REGISTER

TC0M is TC0 timer mode control register to configure TC0 operating mode including TC0 pre-scalar, clock source, PWM function... These configurations must be setup completely before enabling TC0 timer.

0DAH	Bit 7	Bit 6	Bit 5	Bit 4	Bit 3	Bit 2	Bit 1	Bit 0
TC0M	TC0ENB	TC0rate2	TC0rate1	TC0rate0	TC0CKS	-	TC0PO	PWM0OUT
Read/Write	R/W	R/W	R/W	R/W	R/W	-	R/W	R/W
After reset	0	0	0	0	0	-	0	0

- Bit 0 **PWM0OUT**: PWM output control bit.
0 = Disable PWM output function, and P4.6 is GPIO mode.
1 = Enable PWM output function, and P4.6 output PWM signal.
- Bit 1 **TC0PO**: TC0 pulse output function control bit.
0 = Disable TC0 pulse output function.
1 = Enable TC0 pulse output function.
- Bit 3 **TC0CKS**: TC0 clock source select bit.
0 = Fosc.
1 = External input pin (P4.0) and enable event counter function.
- Bit [6:4] **TC0RATE[2:0]**: TC0 timer clock source select bits (**Only support TC0CKS = 0**).
TC0CKS=0, FCLKMD=0:
>> 000 = Fosc/128, 001 = Fosc/64, 010 = Fosc/32, 011 = Fosc/16, 100 = Fosc/8, 101 = Fosc/4, 110 = Fosc/2, 111 = Fosc/1.
TC0CKS=0, FCLKMD=1:
>> 000 = Fosc/128, 001 = Fosc/64, 010 = Fosc/32, 011 = Fosc/16, 100 = Fosc/8, 101 = Fosc/4, 110 = Fosc/2, 111 = Fosc/1.
TC0CKS=1:
>> 000~111 = useless.
- Bit 7 **TC0ENB**: TC0 timer control bit.
0 = Disable TC0 timer.
1 = Enable TC0 timer.

8.3.4 TC0C COUNTING REGISTER

TC0C is TC0 8-bit counter. When TC0C overflow occurs, the TC0IRQ flag is set as "1" and cleared by program. The TC0C decides TC0 interval time through below equation to calculate a correct value. It is necessary to write the correct value to TC0C register and TC0R register first time, and then enable TC0 timer to make sure the first cycle correct. After one TC0 overflow occurs, the TC0C register is loaded a correct value from TC0R register automatically, not program.

0DBH	Bit 7	Bit 6	Bit 5	Bit 4	Bit 3	Bit 2	Bit 1	Bit 0
TC0C	TC0C7	TC0C6	TC0C5	TC0C4	TC0C3	TC0C2	TC0C1	TC0C0
Read/Write	R/W	R/W	R/W	R/W	R/W	R/W	R/W	R/W
After reset	0	0	0	0	0	0	0	0

The equation of TC0C initial value is as following.

$$TC0C \text{ initial value} = 256 - (TC0 \text{ interrupt interval time} * TC0 \text{ clock rate})$$

8.3.5 TC0R AUTO-RELOAD REGISTER

TC0 timer builds in auto-reload function, and TC0R register stores reload data. When TC0C overflow occurs, TC0C register is loaded data from TC0R register automatically. Under TC0 timer counting status, to modify TC0 interval time is to modify TC0R register, not TC0C register. New TC0C data of TC0 interval time will be updated after TC0 timer overflow occurrence, TC0R loads new value to TC0C register. But at the first time to setup TC0M, TC0C and TC0R must be set the same value before enabling TC0 timer. TC0 is double buffer design. If new TC0R value is set by program, the new value is stored in 1st buffer. Until TC0 overflow occurs, the new value moves to real TC0R buffer. This way can avoid any transitional condition to affect the correctness of TC0 interval time and PWM output signal.

ODCH	Bit 7	Bit 6	Bit 5	Bit 4	Bit 3	Bit 2	Bit 1	Bit 0
TC0R	TC0R7	TC0R6	TC0R5	TC0R4	TC0R3	TC0R2	TC0R1	TC0R0
Read/Write	W	W	W	W	W	W	W	W
After reset	0	0	0	0	0	0	0	0

The equation of TC0R initial value is as following.

$$TC0R \text{ initial value} = 256 - (TC0 \text{ interrupt interval time} * TC0 \text{ clock rate})$$

☞ **Example: To calculation TC0C and TC0R value to obtain 100us TC0 interval time. TC0 clock source is Fosc = 16MHz. Select TC0RATE = 011 (Fosc/16).**

TC0 interval time = 100us. TC0 clock rate = 16MHz/16

$$\begin{aligned}
 TC0C/TC0R \text{ initial value} &= 256 - (TC0 \text{ interval time} * \text{input clock}) \\
 &= 256 - (100us * 16MHz / 16) \\
 &= 256 - (100 * 10^{-6} * 16 * 10^6 / 16) \\
 &= 9CH
 \end{aligned}$$

8.3.6 TC0D PWM DUTY REGISTER

TC0D register's purpose is to decide PWM duty. In PWM mode, TC0R controls PWM's cycle, and TC0D controls the duty of PWM. The operation is base on timer counter value. When TC0C = TC0D, the PWM high duty finished and exchange to low level. It is easy to configure TC0D to choose the right PWM's duty for application.

ODDH	Bit 7	Bit 6	Bit 5	Bit 4	Bit 3	Bit 2	Bit 1	Bit 0
TC0D	TC0D7	TC0D6	TC0D5	TC0D4	TC0D3	TC0D2	TC0D1	TC0D0
Read/Write	R/W	R/W	R/W	R/W	R/W	R/W	R/W	R/W
After Reset	0	0	0	0	0	0	0	0

The equation of TC0D initial value is as following.

$$TC0D \text{ initial value} = TC0R + (PWM \text{ high pulse width period} / TC0 \text{ clock rate})$$

☞ **Example: To calculate TC0D value to obtain 1/3 duty PWM signal. The TC0 clock source is Fosc = 16MHz. Select TC0RATE=000 (Fosc/128).**

TC0R = 9CH. TC0 interval time = 800us. So the PWM cycle is 1.25KHz. In 1/3 duty condition, the high pulse width is about 267us.

$$\begin{aligned}
 TC0D \text{ initial value} &= 9CH + (PWM \text{ high pulse width period} / TC0 \text{ clock rate}) \\
 &= 9CH + (267us * 16MHz / 128) \\
 &= 9CH + 21H \\
 &= BDH
 \end{aligned}$$

8.3.7 TC0 EVENT COUNTER

TC0 event counter is set the TC0 clock source from external input pin (P4.0). When TC0CKS=1, TC0 clock source is switch to external input pin (P4.0). TC0 event counter trigger direction is falling edge. When one falling edge occurs, TC0C will up one count. When TC0C counts from 0xFF to 0x00, TC0 triggers overflow event. The external event counter input pin's wake-up function of GPIO mode is disabled when TC0 event counter function enabled to avoid event counter signal trigger system wake-up and not keep in power saving mode. The external event counter input pin's external interrupt function is also disabled when TC0 event counter function enabled, and the P40IRQ bit keeps "0" status. The event counter usually is used to measure external continuous signal rate, e.g. continuous pulse, R/C type oscillating signal...These signal phase don't synchronize with MCU's main clock. Use TC0 event to measure it and calculate the signal rate in program for different applications.

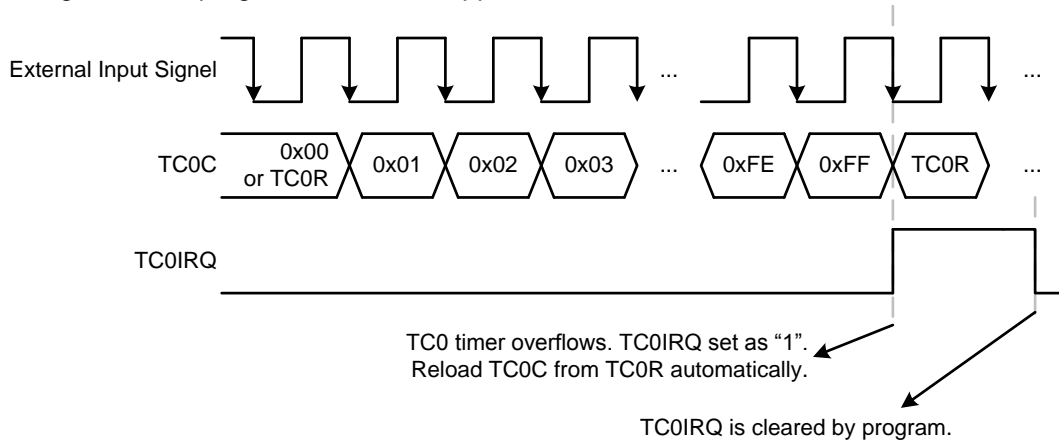

8.3.8 PULSE WIDTH MODULATION (PWM)

The PWM is duty/cycle programmable design to offer various PWM signals. When TC0 timer enables before, PWM0OUT bit sets as "1" (enable PWM output), the PWM output pin (P4.6) outputs PWM signal. **The PWM output signal needs time to synchronize in normal mode and slow mode, so designer should be very carefully to process the synchronous timing and the first PWM duty cycle must be correct. When output PWM function, we must be set PWM0OUT=1 first and then set TC0ENB=1 or PWM duty cycle will be error. When PWM output signal synchronize finishes, the PWM channel exchanges from GPIO to PWM output. When TC0ENB = 0 or PWM0OUT = 0, the PWM channel returns to GPIO mode and last status.** One cycle of PWM signal is high pulse first, and then low pulse outputs. TC0R register controls the cycle of PWM, and TC0D decides the duty (high pulse width length) of PWM. TC0C initial value is TC0R reloaded when TC0 timer enables and TC0 timer overflows. When TC0C count is equal to TC0D, the PWM high pulse finishes and exchanges to low level. When TC0 overflows (TC0C counts from 0xFF to 0x00), one complete PWM cycle finishes. The PWM exchanges to high level for next cycle. The PWM is auto-reload design to load TC0C from TC0R automatically when TC0 overflows and the end of PWM's cycle, to keeps PWM continuity. If modify the PWM duty/cycle by program as PWM outputting, the new cycle occurs at next cycle when TC0C loaded from TC0R.

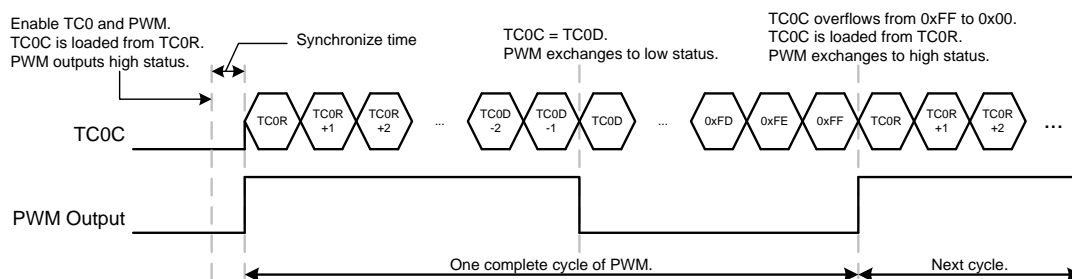

PWM output synchronous + Delay time table:

		Normal Mode		Slow Mode	
		STPHX=0	STPHX=1	STPHX=0	STPHX=1
TC0 clock source	Fhosc	$< (1/F_{hosc} + TC0RATE/F_{hosc})$	X	X	X
	Fosc	X	X	$< (1/F_{osc} + TC0RATE/F_{osc})$	$< (1/F_{osc} + TC0RATE/F_{osc})$
	P4.0	$< 2*(1/F_{event})$	X	$< 2*(1/F_{event})$	$< 2*(1/F_{event})$

PWM stops output and back to GPIO mode's delay time table:

PWES	TC0PO	PWM control bit	TC0 clock source	Normal Mode		Slow Mode	
				STPHX=0	STPHX=1	STPHX=0	STPHX=1
0	0	PWM0OUT = 1→0	Fhosc	immediately	X	X	X
			Fosc	X	X	immediately	immediately
			P4.0	immediately	immediately	immediately	immediately
0	0	TC0ENB = 1→0	Fhosc	immediately	X	X	X
			Fosc	X	X	immediately	immediately
			P4.0	immediately	immediately	immediately	immediately
0	1	PWM0OUT = 1→0 (Auto setting)	Fhosc	immediately (PWM Low level finished)	X	X	X
			Fosc	X	X	immediately (PWM Low level finished)	immediately (PWM Low level finished)
			P4.0	immediately (PWM Low level finished)	X	immediately (PWM Low level finished)	immediately (PWM Low level finished)
01~11	0	PWM0OUT = 1→0	Fhosc	immediately	X	X	X
			Fosc	X	X	immediately	immediately
			P4.0	immediately	immediately	immediately	immediately
		TC0ENB = 1→0	Fhosc	immediately	X	X	X
			Fosc	X	X	immediately	immediately
			P4.0	immediately	immediately	immediately	immediately

Event: P4.0 external clock frequency

The resolution of PWM is decided by TC0R. TC0R range is from 0x00~0xFF. If TC0R = 0x00, PWM's resolution is 1/256. If TC0R = 0x80, PWM's resolution is 1/128. TC0D controls the high pulse width of PWM for PWM's duty. When TC0C = TC0D, PWM output exchanges to low status. TC0D must be greater than TC0R, or the PWM signal keeps low status. When PWM outputs, TC0IRQ still actives as TC0 overflows, and TC0 interrupt function actives as TC0IEN = 1. But strongly recommend be careful to use PWM and TC0 timer together, and make sure both functions work well. The PWM output pin is shared with GPIO and switch to output PWM signal as PWM0OUT=1 automatically. If PWM0OUT bit is cleared to disable PWM, the output pin exchanges to last GPIO mode automatically. It easily to implement carry signal on/off operation, not to control TC0ENB bit.

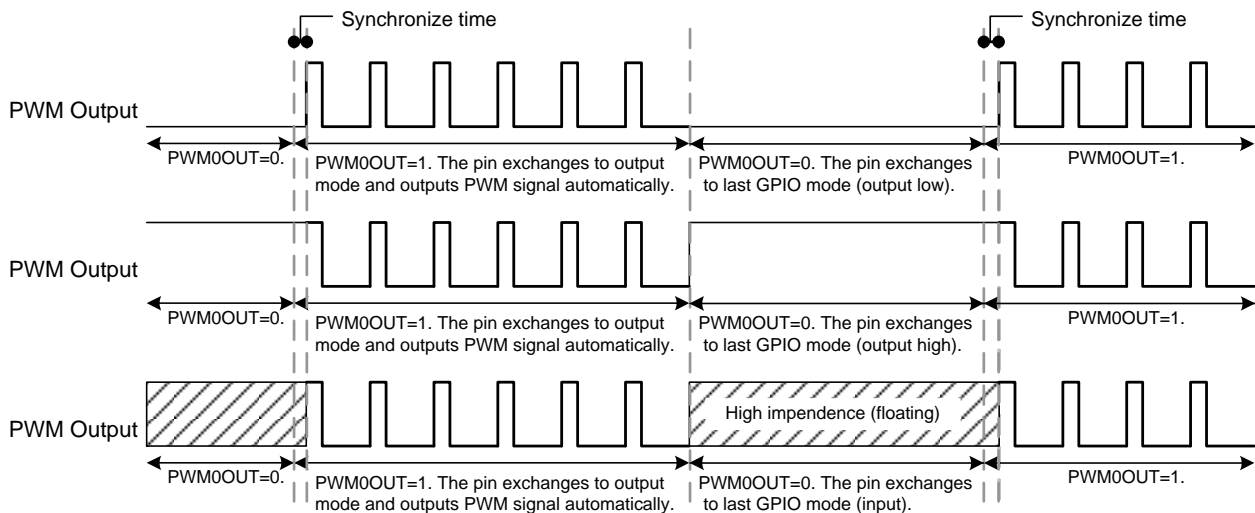

8.3.9 One Pulse PWM

When TC0PO = 0, TC0 is normal timer mode or PWM function mode. When TC0PO = 1 and PWM0OUT=1, TC0 will output one pulse PWM function. **One pulse PWM function output signal needs time to synchronize in normal mode and slow mode. So designer should be very carefully to process the synchronous timing.** When one pulse PWM output signal synchronize finishes, the PWM channel exchanges from GPIO to PWM output. When one pulse PWM output finishes, PWM0OUT bit is cleared automatically, the PWM channel returns to GPIO mode and last status. TC0IRQ is issued as TC0 counter overflow. To output next pulse is to set PWM0OUT bit by program again.

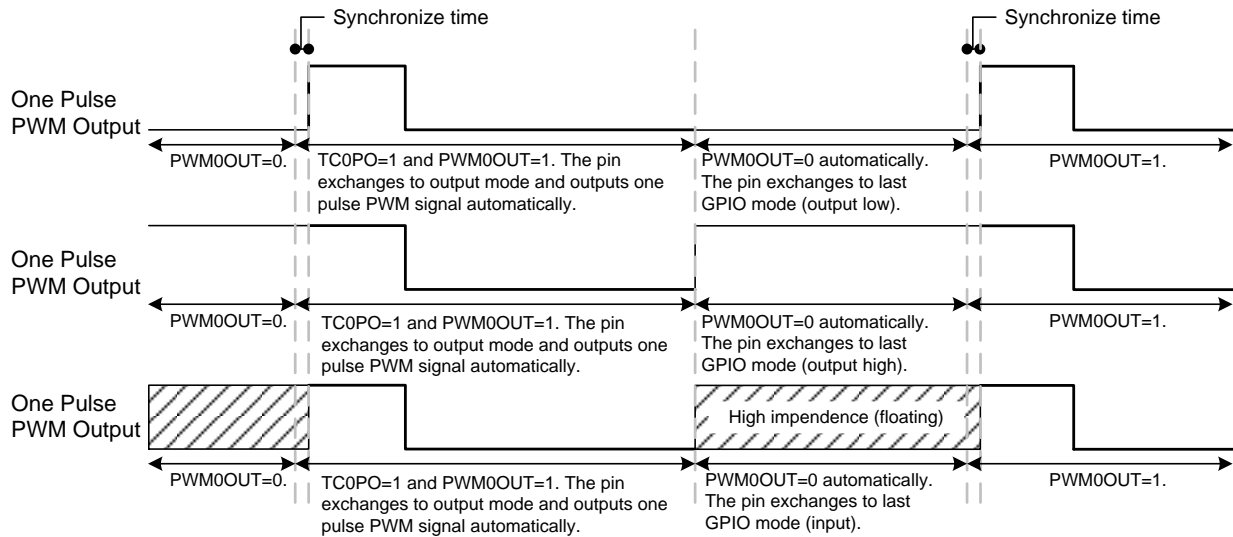

8.3.10 TC0 TIMER OPERATION EXAMPLE

● **TC0 TIMER CONFIGURATION:**

; **Reset TC0 timer.**

```
CLR          TC0M          ; Clear TC0M register.
```

; **Set TC0 clock source and TC0 rate.**

```
MOV          A, #0nnnn000b
B0MOV        TC0M, A
```

; **Set TC0C and TC0R register for TC0 Interval time.**

```
MOV          A, #value    ; TC0C must be equal to TC0R.
B0MOV        TC0C, A
B0MOV        TC0R, A
```

; **Clear TC0IRQ**

```
B0BCLR       FTC0IRQ
```

; **Enable TC0 timer and interrupt function.**

```
B0BSET       FTC0IEN      ; Enable TC0 interrupt function.
B0BSET       FTC0ENB      ; Enable TC0 timer.
```

- **TC0 EVENT COUNTER CONFIGURATION:**

; Reset TC0 timer.

```
CLR          TC0M          ; Clear TC0M register.
```

; Enable TC0 event counter.

```
BOBSET      FTC0CKS       ; Set TC0 clock source from external input pin (P4.0).
```

; Set TC0C and TC0R register for TC0 Interval time.

```
MOV         A, #value     ; TC0C must be equal to TC0R.
BOBMOV     TC0C, A
BOBMOV     TC0R, A
```

; Clear TC0IRQ

```
BOBCLR     FTC0IRQ
```

; Enable TC0 timer and interrupt function.

```
BOBSET     FTC0IEN       ; Enable TC0 interrupt function.
BOBSET     FTC0ENB       ; Enable TC0 timer.
```

- **TC0 PWM CONFIGURATION:**

; Reset TC0 timer.

```
CLR          TC0M          ; Clear TC0M register.
```

; Set TC0 clock source and TC0 rate.

```
MOV         A, #0nnnn000b
BOBMOV     TC0M, A
```

; Set TC0C and TC0R register for PWM cycle.

```
MOV         A, #value1    ; TC0C must be equal to TC0R.
BOBMOV     TC0C, A
BOBMOV     TC0R, A
```

; Set TC0D register for PWM duty.

```
MOV         A, #value2    ; TC0D must be greater than TC0R.
BOBMOV     TC0D, A
```

; Enable PWM and TC0 timer.

```
BOBSET     FPWM0OUT      ; Enable PWM.
BOBSET     FTC0ENB       ; Enable TC0 timer.
```

- **TC0 One Pulse PWM CONFIGURATION:**

; Reset TC0 timer.

```
CLR          TC0M          ; Clear TC0M register.
```

; Set TC0 clock source and TC0 rate.

```
MOV         A, #0nnnn000b
BOBMOV     TC0M, A
```

; Set TC0C and TC0R register for PWM cycle.

```
MOV         A, #value1    ; TC0C must be equal to TC0R.
BOBMOV     TC0C, A
BOBMOV     TC0R, A
```

; Set TC0D register for PWM duty.

```
MOV         A, #value2    ; TC0D must be greater than TC0R.
BOBMOV     TC0D, A
```

; Enable PWM and TC0 timer.

```
BOBSET     FTC0PO        ; Enable One Pulse.
BOBSET     FPWM0OUT      ; Enable PWM.
BOBSET     FTC0ENB       ; Enable TC0 timer.
```



8.4 TC1 8-BIT TIMER/COUNTER

8.4.1 OVERVIEW

The TC1 timer is an 8-bit binary up timer with basic timer, PWM, One Pulse PWM and PWM with extension functions. The basic timer function supports flag indicator (TC1IRQ bit) and interrupt operation (interrupt vector). The interval time is programmable through TC1M, TC1C, TC1R registers. The event counter is changing TC1 clock source from system clock (Fhosc/Fosc) to external clock like signal (e.g. continuous pulse, R/C type oscillating signal...). TC1 becomes a counter to count external clock number to implement measure application. TC1 also builds in duty/cycle programmable PWM. The PWM cycle and resolution are controlled by TC1 timer clock rate, TC1R and TC1D registers. So the PWM with good flexibility to implement IR carry signal, motor control and brightness adjuster.... TC1 PWM function also supports one pulse output signal that means only output one cycle PWM signal, not continuous. The PWM has two programmable channels shared with GPIO pins and controlled by PWCH[1:0] bit. The output operation must be through enabled each bit/channel of PWCH[1:0] bits. The enabled PWM channel exchanges from GPIO to PWM output. When the PWCH[1:0] bits disables, the PWM channel returns to GPIO mode and last status. And support the 2-channel PWM output with extension selected by PWES[1:0] bits. TC1 counter supports auto-reload function which always enabled. When TC1 timer overflow occurs, the TC1C will be reloaded from TC1R automatically. The auto-reload function is always enabled. The TC1 doesn't build in green mode wake-up function.

The main purposes of the TC1 timer are as following.

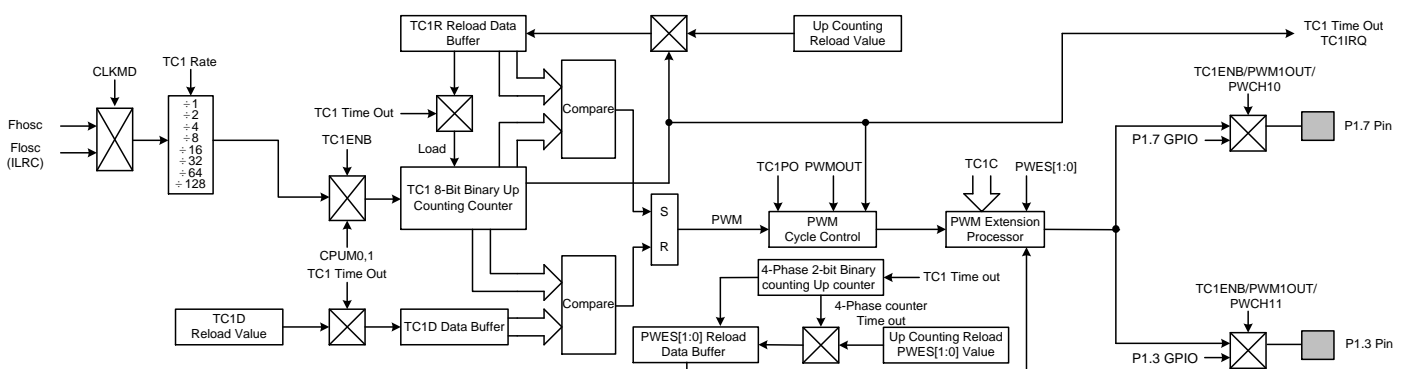
- ☞ **8-bit programmable up counting timer:** Generate time-out at specific time intervals based on the selected clock frequency.
- ☞ **Interrupt function:** TC1 timer function supports interrupt function. When TC1 timer occurs overflow, the TC1IRQ activates and the system points program counter to interrupt vector to do interrupt sequence.
- ☞ **Duty/cycle programmable PWM:** The PWM is duty/cycle programmable controlled by TC1R and TC1D registers.
- ☞ **One Pulse PWM:** The one pulse PWM is controlled by TC1PO bit. When TC1PO=0, TC1 is normal timer mode or PWM function mode. When TC1PO=1, TC1 is one pulse PWM function. When PWMOUT=1, one pulse PWM outputs and the TC1IRQ is issued as TC1 counter overflow, PWMOUT bit is cleared automatically, the PWM channel returns to GPIO mode and last status. **One Pulse PWM doesn't support extension function (PWES[1:0]).**
- ☞ **2-Channel PWM output:** The 2-channel PWM output are controlled by PWCH[1:0] bits.
- ☞ **PWM output with Extension function: The PWM with extension function is four phases design.** The PWM output with extension function are controlled by PWES[1:0] bits.
- ☞ **Green mode function:** All TC1 functions (timer, PWM, event counter, auto-reload, extension) keeps running in green mode, but no wake-up function. Timer IRQ actives as any IRQ trigger occurrence, e.g. timer overflow...



8.4.2 TC1 TIMER OPERATION

TC1 timer is controlled by TC1ENB bit. When TC1ENB=0, TC1 timer stops. When TC1ENB=1, TC1 timer starts to count. Before enabling TC1 timer, setup TC1 timer's configurations to select timer function modes, e.g. basic timer, interrupt function...TC1C increases "1" by timer clock source. When TC1 overflow event occurs, TC1IRQ flag is set as "1" to indicate overflow and cleared by program. The overflow condition is TC1C count from full scale (0xFF) to zero scale (0x00). In difference function modes, TC1C value relates to operation. If TC1C value changing effects operation, the transition of operations would make timer function error. So TC1 builds in double buffer to avoid these situations happen. The double buffer concept is to flash TC1C during TC1 counting, to set the new value to TC1R (reload buffer), and the new value will be loaded from TC1R to TC1C after TC1 overflow occurrence automatically. In the next cycle, the TC1 timer runs under new conditions, and no any transitions occur. The auto-reload function is no any control interface and always actives as TC1 enables. If TC1 timer interrupt function is enabled (TC1IEN=1), the system will execute interrupt procedure. The interrupt procedure is system program counter points to interrupt vector (ORG 0008H) and executes interrupt service routine after TC1 overflow occurrence. Clear TC1IRQ by program is necessary in interrupt procedure. TC1 timer can works in normal mode, slow mode and green mode. Under green mode, TC1 keep counting, set TC1IRQ and outputs PWM, can't wake-up system.

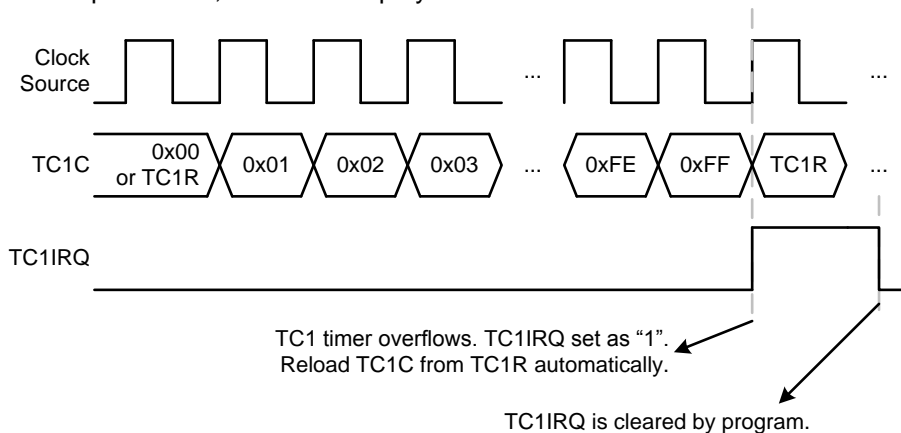

TC1 provides different clock sources to implement different applications and configurations. TC1 clock source includes Fosc (high speed oscillator), Fosc (low speed RC oscillator) controlled by FCLKMD bit. If FCLKMD=0, TC1 clock source is Fosc through TC1rate[2:0] pre-scalar to decide Fosc/1~Fosc/128. If FCLKMD=1, TC1 clock source is Fosc through TC1rate[2:0] pre-scalar to decide Fosc/1~Fosc/128. TC1 length is 8-bit (256 steps), and the one count period is each cycle of input clock.

CLKMD	TC1rate[2:0]	TC1 Clock	TC1 Interval Time			
			Fosc=16MHz, Fcpu=Fosc/4		Fosc=4MHz, Fcpu=Fosc/4	
			max. (us)	Unit (us)	max. (us)	Unit (us)
0	000b	Fosc/128	2048	8	8192	32
0	001b	Fosc/64	1024	4	4096	16
0	010b	Fosc/32	512	2	2048	8
0	011b	Fosc/16	256	1	1024	4
0	100b	Fosc/8	128	0.5	512	2
0	101b	Fosc/4	64	0.25	256	1
0	110b	Fosc/2	32	0.125	128	0.5
0	111b	Fosc/1	16	0.0625	64	0.25
CLKMD	TC1rate[2:0]	TC1 Clock	TC1 Interval Time			
			Fosc=32KHz, Fcpu=Fosc/4		Fosc=16KHz, Fcpu=Fosc/4	
			max. (ms)	Unit (ms)	max. (ms)	Unit (ms)
1	000b	Fosc/128	1024	4	2048	8
1	001b	Fosc/64	512	2	1024	4
1	010b	Fosc/32	256	1	512	2
1	011b	Fosc/16	128	0.5	256	1
1	100b	Fosc/8	64	0.25	128	0.5
1	101b	Fosc/4	32	0.125	64	0.25
1	110b	Fosc/2	16	0.0625	32	0.125
1	111b	Fosc/1	8	0.03125	16	0.0625

8.4.3 TC1M MODE REGISTER

TC1M is TC1 timer mode control register to configure TC1 operating mode including TC1 pre-scalar, clock source, PWM function... These configurations must be setup completely before enabling TC1 timer.

0A0H	Bit 7	Bit 6	Bit 5	Bit 4	Bit 3	Bit 2	Bit 1	Bit 0
TC1M	TC1ENB	TC1rate2	TC1rate1	TC1rate0	-	-	TC1PO	PWM1OUT
Read/Write	R/W	R/W	R/W	R/W	-	-	R/W	R/W
After reset	0	0	0	0	-	-	0	0

- Bit 0 **PWM1OUT:** PWM output control bit.
0 = Disable PWM output function, and P1.7, P1.3 (controlled by PWCH[1:0] bits) are GPIO mode.
1 = Enable PWM output function, and P1.7, P1.3 (controlled by PWCH[1:0] bits) output PWM signal.
- Bit 1 **TC1PO:** TC1 pulse output function control bit.
0 = Disable TC1 pulse output function.
1 = Enable TC1 pulse output function.
- Bit [6:4] **TC1RATE[2:0]:** TC1 timer clock source select bits.
FCLKMD=0:
>> 000 = Fhosc/128, 001 = Fhosc/64, 010 = Fhosc/32, 011 = Fhosc/16, 100 = Fhosc/8, 101 = Fhosc/4,
110 = Fhosc/2, 111 = Fhosc/1.
FCLKMD=1:
>> 000 = Fosc/128, 001 = Fosc/64, 010 = Fosc/32, 011 = Fosc/16, 100 = Fosc/8, 101 = Fosc/4, 110 =
Fosc/2, 111 = Fosc/1.
- Bit 7 **TC1ENB:** TC1 timer control bit.
0 = Disable TC1 timer.
1 = Enable TC1 timer.

8.4.4 TC1C COUNTING REGISTER

TC1C is TC1 8-bit counter. When TC1C overflow occurs, the TC1IRQ flag is set as "1" and cleared by program. The TC1C decides TC1 interval time through below equation to calculate a correct value. It is necessary to write the correct value to TC1C register and TC1R register first time, and then enable TC1 timer to make sure the first cycle correct. After one TC1 overflow occurs, the TC1C register is loaded a correct value from TC1R register automatically, not program.

0A1H	Bit 7	Bit 6	Bit 5	Bit 4	Bit 3	Bit 2	Bit 1	Bit 0
TC1C	TC1C7	TC1C6	TC1C5	TC1C4	TC1C3	TC1C2	TC1C1	TC1C0
Read/Write	R/W	R/W	R/W	R/W	R/W	R/W	R/W	R/W
After reset	0	0	0	0	0	0	0	0

The equation of TC1C initial value is as following.

$$TC1C \text{ initial value} = 256 - (TC1 \text{ interrupt interval time} * TC1 \text{ clock rate})$$

8.4.5 TC1R AUTO-RELOAD REGISTER

TC1 timer builds in auto-reload function, and TC1R register stores reload data. When TC1C overflow occurs, TC1C register is loaded data from TC1R register automatically. Under TC1 timer counting status, to modify TC1 interval time is to modify TC1R register, not TC1C register. New TC1C data of TC1 interval time will be updated after TC1 timer overflow occurrence, TC1R loads new value to TC1C register. But at the first time to setup TC1M, TC1C and TC1R must be set the same value before enabling TC1 timer. TC1 is double buffer design. If new TC1R value is set by program, the new value is stored in 1st buffer. Until TC1 overflow occurs, the new value moves to real TC1R buffer. This way can avoid any transitional condition to affect the correctness of TC1 interval time and PWM output signal.

0A2H	Bit 7	Bit 6	Bit 5	Bit 4	Bit 3	Bit 2	Bit 1	Bit 0
TC1R	TC1R7	TC1R6	TC1R5	TC1R4	TC1R3	TC1R2	TC1R1	TC1R0
Read/Write	W	W	W	W	W	W	W	W
After reset	0	0	0	0	0	0	0	0

The equation of TC1R initial value is as following.

$$TC1R \text{ initial value} = 256 - (TC1 \text{ interrupt interval time} * TC1 \text{ clock rate})$$

☞ **Example: To calculation TC1C and TC1R value to obtain 100us TC1 interval time. TC1 clock source is Fosc = 16MHz. Select TC1RATE = 011 (Fosc/16).**
TC1 interval time = 100us. TC1 clock rate = 16MHz/16

$$\begin{aligned} TC1C/TC1R \text{ initial value} &= 256 - (TC1 \text{ interval time} * \text{input clock}) \\ &= 256 - (100us * 16MHz / 16) \\ &= 256 - (100 * 10^{-6} * 16 * 10^6 / 16) \\ &= 9CH \end{aligned}$$

8.4.6 TC1D PWM DUTY REGISTER

TC1D register's purpose is to decide PWM duty. In PWM mode, TC1R controls PWM's cycle, and TC1D controls the duty of PWM. The operation is base on timer counter value. When TC1C = TC1D, the PWM high duty finished and exchange to low level. It is easy to configure TC1D to choose the right PWM's duty for application.

0A3H	Bit 7	Bit 6	Bit 5	Bit 4	Bit 3	Bit 2	Bit 1	Bit 0
TC1D	TC1D7	TC1D6	TC1D5	TC1D4	TC1D3	TC1D2	TC1D1	TC1D0
Read/Write	R/W	R/W	R/W	R/W	R/W	R/W	R/W	R/W
After Reset	0	0	0	0	0	0	0	0

The equation of TC1D initial value is as following.

$$TC1D \text{ initial value} = TC1R + (PWM \text{ high pulse width period} / TC1 \text{ clock rate})$$

☞ **Example: To calculate TC1D value to obtain 1/3 duty PWM signal. The TC1 clock source is Fosc = 16MHz. Select TC1RATE=000 (Fosc/128).**
TC1R = 9CH. TC1 interval time = 800us. So the PWM cycle is 1.25KHz. In 1/3 duty condition, the high pulse width is about 267us.

$$\begin{aligned} TC1D \text{ initial value} &= 9CH + (PWM \text{ high pulse width period} / TC1 \text{ clock rate}) \\ &= 9CH + (267us * 16MHz / 128) \\ &= 9CH + 21H \\ &= BDH \end{aligned}$$

8.4.7 PULSE WIDTH MODULATION (PWM)

The PWM is duty/cycle programmable design to offer various PWM signals. When TC1 timer enables before, PWM1OUT bit sets as “1” (enable PWM output) and select PWM output pin (PWCH[1:0]), the PWM output pin (P1.7, P1.3) outputs PWM signal. **The PWM output signal needs time to synchronize in normal mode and slow mode, so designer should be very carefully to process the synchronous timing and the first PWM duty cycle must be correct. When output PWM function, we must be set PWM1OUT=1 first and then set TC1ENB=1 or PWM duty cycle will be error. When PWM output signal synchronize finishes, the PWM channel exchanges from GPIO to PWM output. When TC1ENB = 0 or PWM1OUT = 0, the PWM channel returns to GPIO mode and last status.** One cycle of PWM signal is high pulse first, and then low pulse outputs. TC1R register controls the cycle of PWM, and TC1D decides the duty (high pulse width length) of PWM. TC1C initial value is TC1R reloaded when TC1 timer enables and TC1 timer overflows. When TC1C count is equal to TC1D, the PWM high pulse finishes and exchanges to low level. When TC1 overflows (TC1C counts from 0xFF to 0x00), one complete PWM cycle finishes. The PWM exchanges to high level for next cycle. The PWM is auto-reload design to load TC1C from TC1R automatically when TC1 overflows and the end of PWM’s cycle, to keeps PWM continuity. If modify the PWM duty/cycle by program as PWM outputting, the new cycle occurs at next cycle when TC1C loaded from TC1R. The PWM channels selected by PWCH[1:0] bits. PWM10, PWM11 output pin is P1.7, P1.3. The PWM10, PWM11 output pins are shared with GPIO pin controlled by PWCH[1:0] bits.

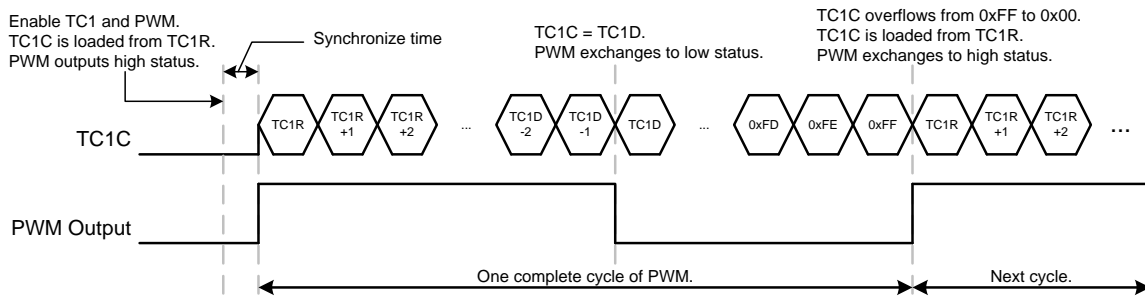

PWM output synchronous + Delay time table:

		Normal Mode		Slow Mode	
		STPHX=0	STPHX=1	STPHX=0	STPHX=1
TC1 clock source	Fhosc	$< (1/F_{hosc} + TC1RATE/F_{hosc})$	X	X	X
	Fosc	X	X	$< (1/F_{osc} + TC1RATE/F_{osc})$	$< (1/F_{osc} + TC1RATE/F_{osc})$

PWM stops output and back to GPIO mode’s delay time table:

PWES	TC1PO	PWM control bit	TC1 clock source	Normal Mode		Slow Mode	
				STPHX=0	STPHX=1	STPHX=0	STPHX=1
0	0	PWM1OUT = 1→0	Fhosc	immediately	X	X	X
			Fosc	X	X	immediately	immediately
0	0	TC1ENB = 1→0	Fhosc	immediately	X	X	X
			Fosc	X	X	immediately	immediately
0	1	PWM1OUT = 1→0 (Auto setting)	Fhosc	immediately (PWM Low level finished)	X	X	X
			Fosc	X	X	immediately (PWM Low level finished)	immediately (PWM Low level finished)
01~11	0	PWM1OUT = 1→0	Fhosc	immediately	X	X	X
			Fosc	X	X	immediately	immediately
		TC1ENB = 1→0	Fhosc	immediately	X	X	X

The resolution of PWM is decided by TC1R. TC1R range is from 0x00~0xFF. If TC1R = 0x00, PWM’s resolution is 1/256. If TC1R = 0x80, PWM’s resolution is 1/128. TC1D controls the high pulse width of PWM for PWM’s duty. When TC1C = TC1D, PWM output exchanges to low status. TC1D must be greater than TC1R, or the PWM signal keeps low status. When PWM outputs, TC1IRQ still actives as TC1 overflows, and TC1 interrupt function actives as TC1IEN = 1. But strongly recommend be careful to use PWM and TC1 timer together, and make sure both functions work well. The PWM output pin is shared with GPIO and switch to output PWM signal as PWM1OUT=1 automatically. If PWM1OUT bit is cleared to disable PWM, the output pin exchanges to last GPIO mode automatically. It easily to implement carry signal on/off operation, not to control TC1ENB bit.

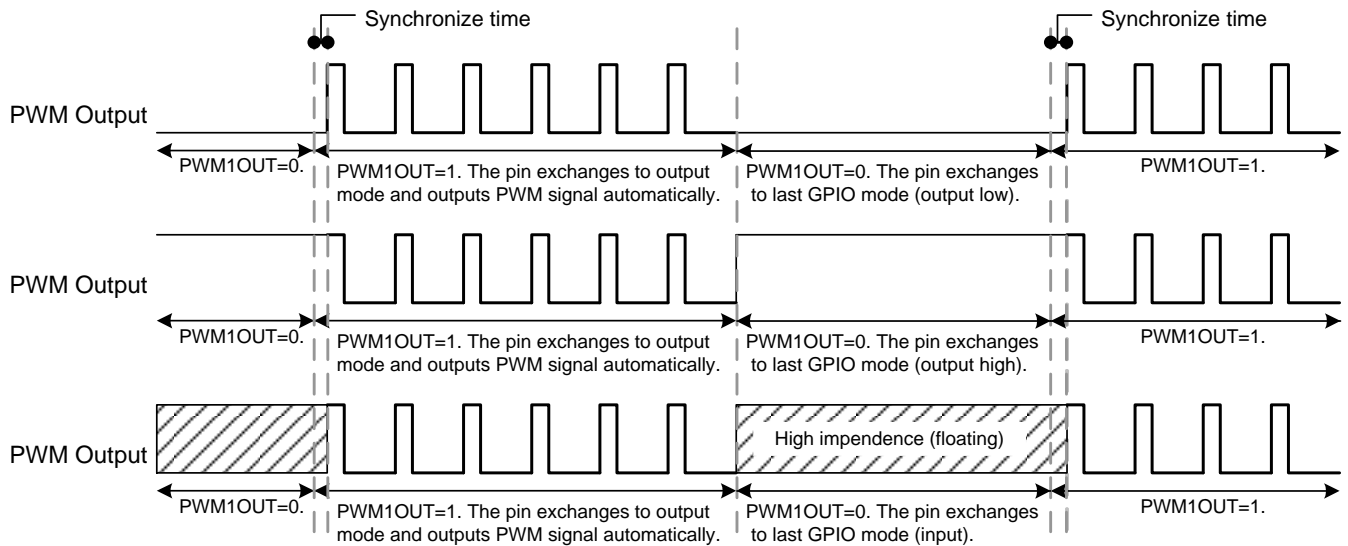

ACH	Bit 7	Bit 6	Bit 5	Bit 4	Bit 3	Bit 2	Bit 1	Bit 0
PWCH			PWCH31	PWCH30	PWCH21	PWCH20	PWCH11	PWCH10
Read/Write			R/W	R/W	R/W	R/W	R/W	R/W
After Reset			0	0	0	0	0	0

Bit 1 **PWCH11:** PWM11 control bit.
0 = P1.3 pin GPIO mode.
1 = PWM11 output.

Bit 0 **PWCH10:** PWM10 control bit.
0 = P1.7 pin GPIO mode.
1 = PWM10 output.

DEH	Bit 7	Bit 6	Bit 5	Bit 4	Bit 3	Bit 2	Bit 1	Bit 0
PWES			PW3ES1	PW3ES0	PW2ES1	PW2ES0	PW1ES1	PW1ES0
Read/Write			R/W	R/W	R/W	R/W	R/W	R/W
After Reset			0	0	0	0	0	0

Bit [1:0] **PW1ES[1:0]:** The PWM1 output with extension control bits (**One pulse PWM function doesn't support**).
00: None compensation.
01: Compensation 1 count at phase 1 of TC1 PWM output.
10: Compensation 1 count at phase 1/3 of TC1 PWM output.
11: Compensation 1 count at phase 1/2/3 of TC1 PWM output.

- If TC1ENB = PWM1OUT = 1 and PWCH[1:0] = 0, PWM doesn't output and P1.7, P1.3 still GPIO mode.
- PWM includes 2-channel selected through PWCH[1:0] bits. If the related bits of PWCH[1:0] are enabled, the related pin outputs PWM signal. If the bit is disabled, the pin returns to last GPIO mode.
- If PWM output with extension function enable first, then disable (TC1ENB=0), and enable (TC1ENB=1), 4-phase PWM 2-bit counter will be reset.

8.4.8 2-Channel PWM

The GPIO mode of 2-channel PWM output pins can be the idle status of PWM signal. PWM high idle status is GPIO output high mode. PWM low idle status is GPIO output low mode. PWM high impedance idle status is GPIO input mode. Select a right "PWM" idle status is very important for loading control as PWM disable. The PWM signal is generated from internal PWM processor and outputs to external pin (P1.7, P1.3) through PWCH[1:0] bits channel selections. **If the related bits of PWCH[1:0] are enabled, the related pin outputs PWM signal. If the bit is disabled, the pin returns to last GPIO mode.** The PWM signal of internal source and external pins are the same. The channel selections only switch PWM channels and not process the phase of PWM signal.

8.4.9 One Pulse PWM

When TC1PO = 0, TC1 is normal timer mode or PWM function mode. When TC1PO = 1 and PWM1OUT=1, TC1 will output one pulse PWM function. **One pulse PWM function output signal needs time to synchronize in normal mode and slow mode. So designer should be very carefully to process the synchronous timing.** When one pulse PWM output signal synchronize finishes, the PWM channel exchanges from GPIO to PWM output. When one pulse PWM output finishes, PWM1OUT bit is cleared automatically, the PWM channel returns to GPIO mode and last status. TC1IRQ is issued as TC1 counter overflow. To output next pulse is to set PWM1OUT bit by program again. One pulse PWM channels selected by PWCH[1:0] bits. PWM10, PWM11 output pin is P1.7, P1.3. The PWM10, PWM11 output pins are shared with GPIO pin controlled by PWCH[1:0] bits.

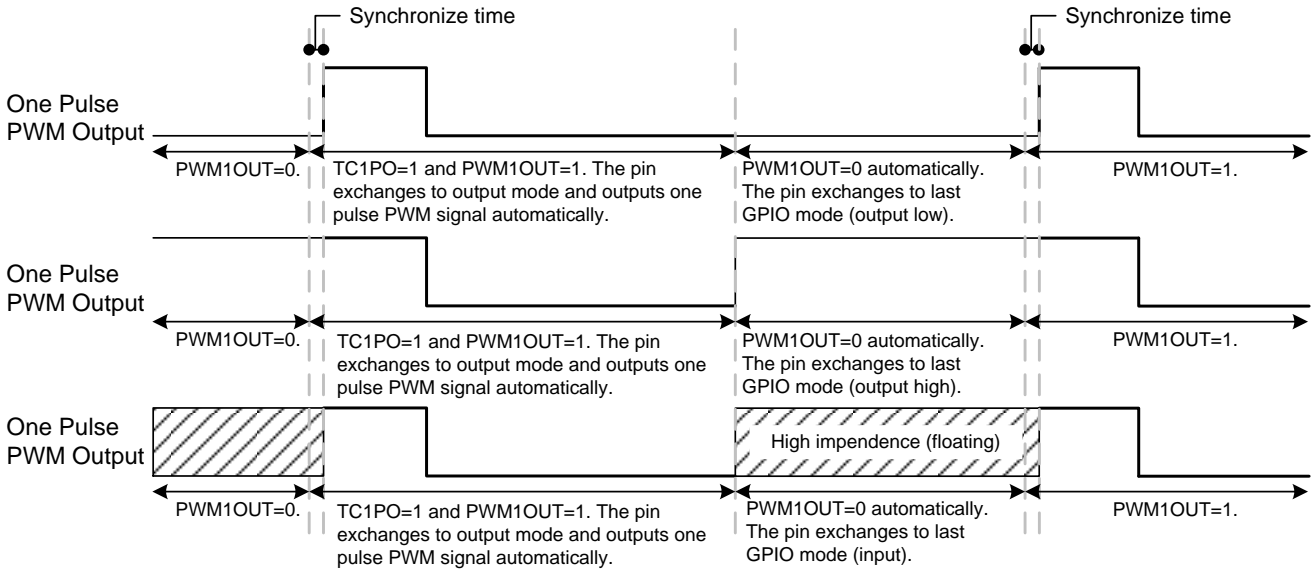

8.4.10 PWM output with Extension function

The PWM extension function supports TC1 PWM function only. One pulse PWM function doesn't support PWM extension function. The PWM extension function controlled by PWES[1:0] bits. If PWES[1:0] = 00, PWM extension function is none compensation. The PWM extension function compensates high level status period at low width of duty cycle. **The PWM with extension function is four phases design. One cycle of PWM with extension function is combined from four sub-cycle signals.** The duty of PWM with extension function is placed in each of sub-cycle. The duty output sequence of the four phases is a special design and through PWM phase processor to allot the duty to each phase. The PWM output with extension function designs auto-reload function. If modify the PWES[1:0] by program as PWM outputting, the new PWM with extension function occurs at next cycle and not change immediately. The methods can avoid the transitional duty occurrence. The PWM output with extension function compensate phase1~phase3 at TC1C from 254 to 255 cont instantaneous. The compensate phase time is one count (TC1C is from 255 to overflow: 1 count period time). If user modify PWES[1:0] bits, the new PWM will be change after current 4-phase PWM cycle finished.

TC1C = TC1R = 244, TC1D = 250, High width = 6, Low width = 6, PWM output.

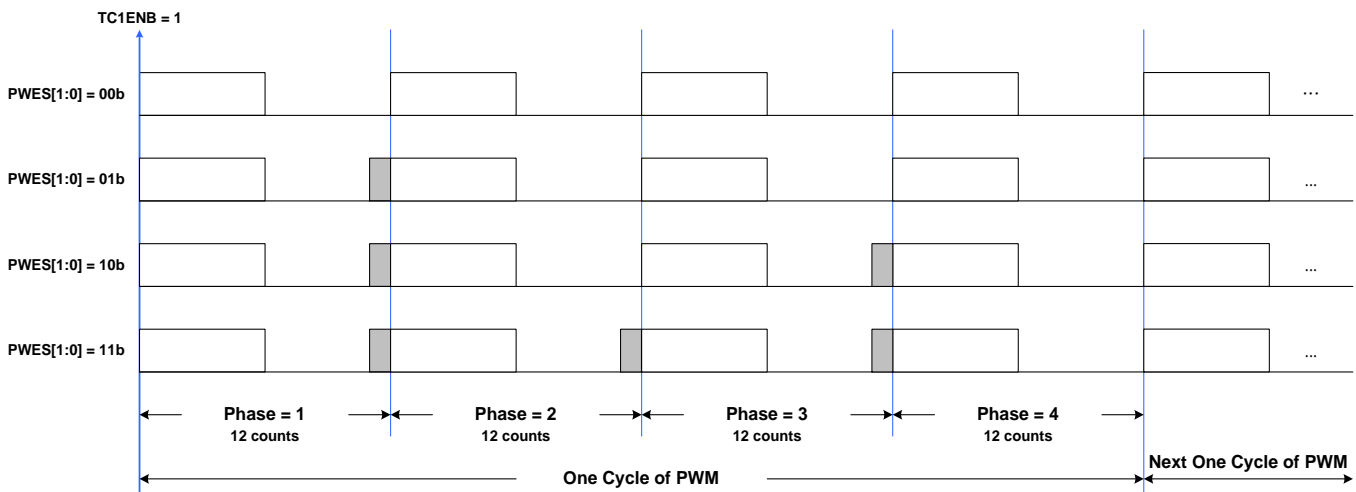

: Compensation 1 count.

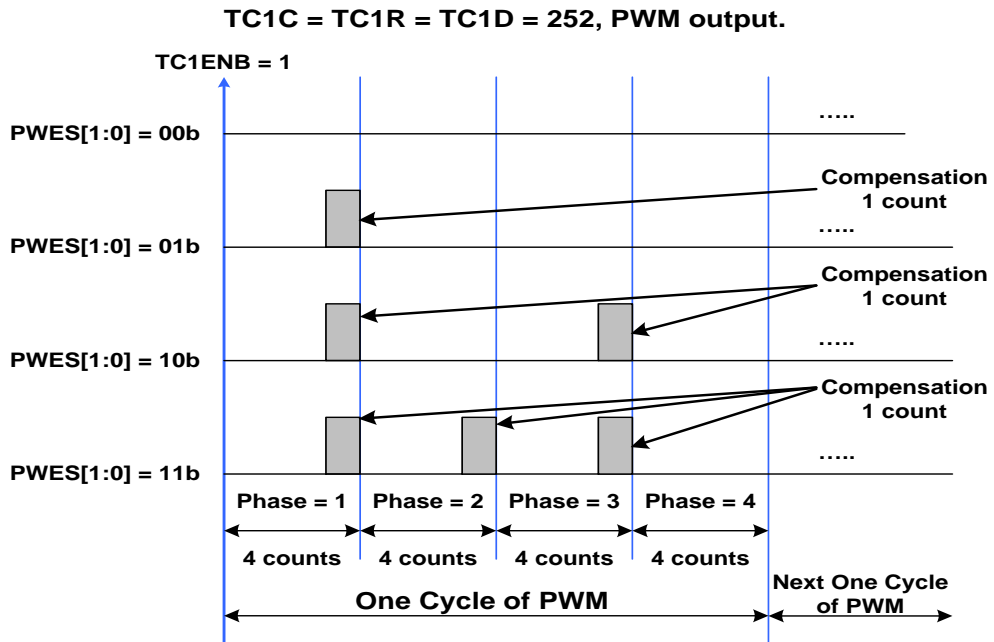

: Compensation 1 count.

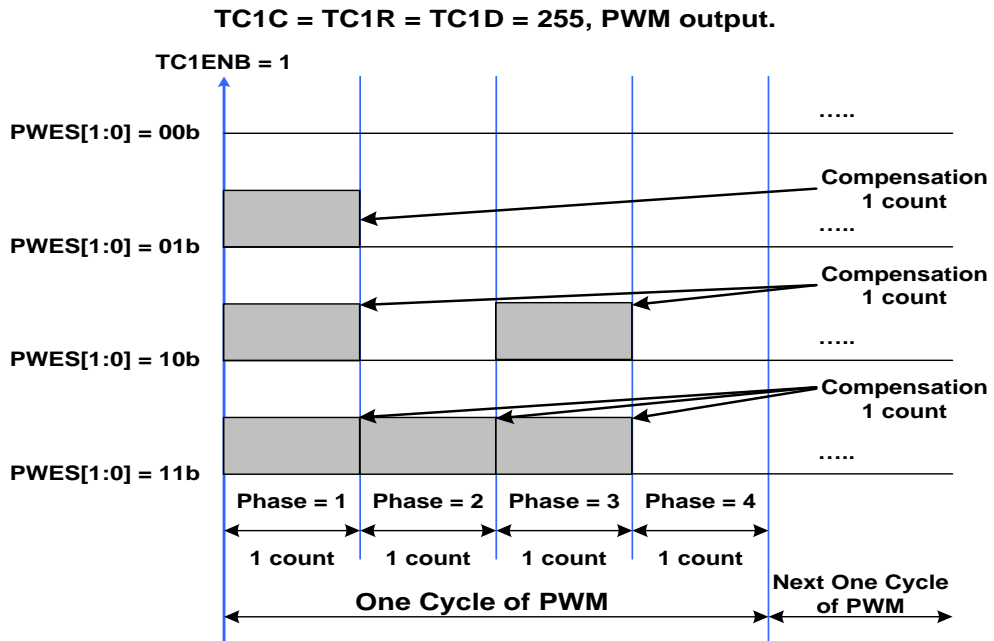

: Compensation 1 count.

8.4.11 TC1 TIMER OPERATION EXAMPLE

● TC1 TIMER CONFIGURATION:

; Reset TC1 timer.

```
CLR          TC1M          ; Clear TC1M register.
```

; Set TC1 clock source and TC1 rate.

```
MOV          A, #0nnn0000b
B0MOV        TC1M, A
```

; Set TC1C and TC1R register for TC1 Interval time.

```
MOV          A, #value      ; TC1C must be equal to TC1R.
B0MOV        TC1C, A
B0MOV        TC1R, A
```

; Clear TC1IRQ

```
B0BCLR       FTC1IRQ
```

; Enable TC1 timer and interrupt function.

```
B0BSET       FTC1IEN      ; Enable TC1 interrupt function.
B0BSET       FTC1ENB      ; Enable TC1 timer.
```

● TC1 PWM CONFIGURATION:

; Reset TC1 timer.

```
CLR          TC1M          ; Clear TC1M register.
```

; Set TC1 clock source and TC1 rate.

```
MOV          A, #0nnn0000b
B0MOV        TC1M, A
```

; Set TC1C and TC1R register for PWM cycle.

```
MOV          A, #value1     ; TC1C must be equal to TC1R.
B0MOV        TC1C, A
B0MOV        TC1R, A
```

; Set TC1D register for PWM duty.

```
MOV          A, #value2     ; TC1D must be greater than TC1R.
B0MOV        TC1D, A
```

; Set PWM channel.

```
MOV          A, #000000nnb
B0MOV        PWCH, A
```

; Enable PWM and TC1 timer.

```
B0BSET       FPWM1OUT     ; Enable PWM.
B0BSET       FTC1ENB     ; Enable TC1 timer.
```

- **TC1 One Pulse PWM CONFIGURATION:**

```

; Reset TC1 timer.
      CLR          TC1M          ; Clear TC1M register.

; Set TC1 clock source and TC1 rate.
      MOV          A, #0nnn0000b
      B0MOV       TC1M, A

; Set TC1C and TC1R register for PWM cycle.
      MOV          A, #value1    ; TC1C must be equal to TC1R.
      B0MOV       TC1C, A
      B0MOV       TC1R, A

; Set TC1D register for PWM duty.
      MOV          A, #value2    ; TC1D must be greater than TC1R.
      B0MOV       TC1D, A

; Set PWM channel.
      MOV          A, #000000nnb
      B0MOV       PWCH, A

; Enable PWM and TC1 timer.
      BOBSET      FTC1PO        ; Enable One Pulse.
      BOBSET      FPWM1OUT     ; Enable PWM.
      BOBSET      FTC1ENB      ; Enable TC1 timer.

```

- **TC1 PWM WITH EXTENSION CONFIGURATION:**

```

; Reset TC1 timer.
      CLR          TC1M          ; Clear TC1M register.

; Set TC1 clock source and TC1 rate.
      MOV          A, #0nnn0000b
      B0MOV       TC1M, A

; Set TC1C and TC1R register for PWM cycle.
      MOV          A, #value1    ; TC1C must be equal to TC1R.
      B0MOV       TC1C, A
      B0MOV       TC1R, A

; Set TC1D register for PWM duty.
      MOV          A, #value2    ; TC1D must be greater than TC1R.
      B0MOV       TC1D, A

; Set PWM channel and Extension.
      MOV          A, #000000nnb
      B0MOV       PWCH, A
      MOV          A, #000000nnb
      B0MOV       PWES, A

; Enable PWM and TC1 timer.
      BOBSET      FPWM1OUT     ; Enable PWM.
      BOBSET      FTC1ENB      ; Enable TC1 timer.

```

TC2 8-BIT TIMER/COUNTER

8.4.12 OVERVIEW

The TC2 timer is an 8-bit binary up timer with basic timer, PWM, One Pulse PWM and PWM with extension functions. The basic timer function supports flag indicator (TC2IRQ bit) and interrupt operation (interrupt vector). The interval time is programmable through TC2M, TC2C, TC2R registers. The event counter is changing TC2 clock source from system clock (Fhosc/Fosc) to external clock like signal (e.g. continuous pulse, R/C type oscillating signal...). TC2 becomes a counter to count external clock number to implement measure application. TC2 also builds in duty/cycle programmable PWM. The PWM cycle and resolution are controlled by TC2 timer clock rate, TC2R and TC2D registers. So the PWM with good flexibility to implement IR carry signal, motor control and brightness adjuster.... TC2 PWM function also supports one pulse output signal that means only output one cycle PWM signal, not continuous. The PWM has two programmable channels shared with GPIO pins and controlled by PWCH[3:2] bit. The output operation must be through enabled each bit/channel of PWCH[3:2] bits. The enabled PWM channel exchanges from GPIO to PWM output. When the PWCH[3:2] bits disables, the PWM channel returns to GPIO mode and last status. And support the 2-channel PWM output with extension selected by PWES[3:2] bits. TC2 counter supports auto-reload function which always enabled. When TC2 timer overflow occurs, the TC2C will be reloaded from TC2R automatically. The auto-reload function is always enabled. The TC2 doesn't build in green mode wake-up function.

The main purposes of the TC2 timer are as following.

- ☞ **8-bit programmable up counting timer:** Generate time-out at specific time intervals based on the selected clock frequency.
- ☞ **Interrupt function:** TC2 timer function supports interrupt function. When TC2 timer occurs overflow, the TC2IRQ activates and the system points program counter to interrupt vector to do interrupt sequence.
- ☞ **Duty/cycle programmable PWM:** The PWM is duty/cycle programmable controlled by TC2R and TC2D registers.
- ☞ **One Pulse PWM:** The one pulse PWM is controlled by TC2PO bit. When TC2PO=0, TC2 is normal timer mode or PWM function mode. When TC2PO=1, TC2 is one pulse PWM function. When PWMOUT=1, one pulse PWM outputs and the TC2IRQ is issued as TC2 counter overflow, PWMOUT bit is cleared automatically, the PWM channel returns to GPIO mode and last status. **One Pulse PWM doesn't support extension function (PWES[3:2]).**
- ☞ **2-Channel PWM output:** The 2-channel PWM output are controlled by PWCH[3:2] bits.
- ☞ **PWM output with Extension function:** The PWM with extension function is four phases design. The PWM output with extension function are controlled by PWES[3:2] bits.
- ☞ **Green mode function:** All TC2 functions (timer, PWM, event counter, auto-reload, extension) keeps running in green mode, but no wake-up function. Timer IRQ actives as any IRQ trigger occurrence, e.g. timer overflow...

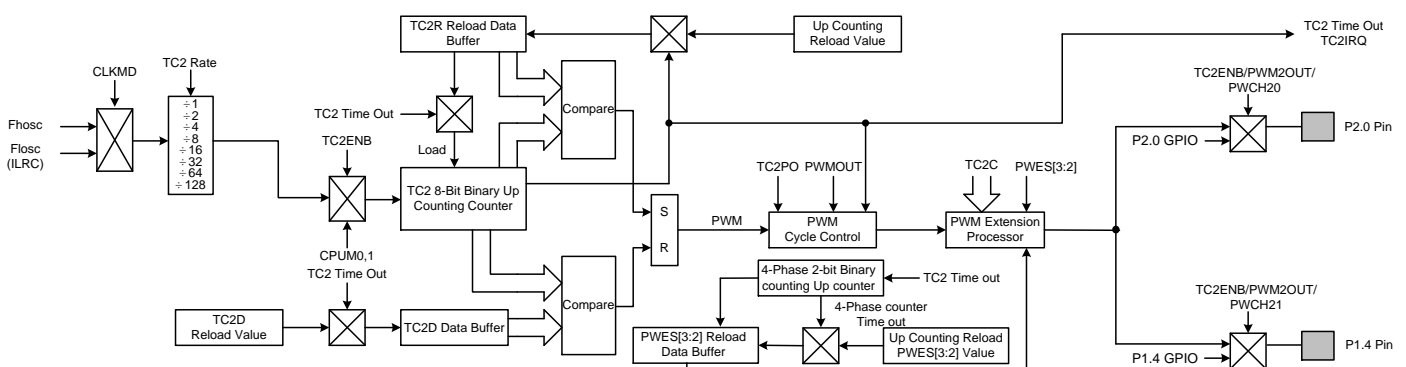

8.4.13 TC2 TIMER OPERATION

TC2 timer is controlled by TC2ENB bit. When TC2ENB=0, TC2 timer stops. When TC2ENB=1, TC2 timer starts to count. Before enabling TC2 timer, setup TC2 timer's configurations to select timer function modes, e.g. basic timer, interrupt function...TC2C increases "1" by timer clock source. When TC2 overflow event occurs, TC2IRQ flag is set as "1" to indicate overflow and cleared by program. The overflow condition is TC2C count from full scale (0xFF) to zero scale (0x00). In difference function modes, TC2C value relates to operation. If TC2C value changing effects operation, the transition of operations would make timer function error. So TC2 builds in double buffer to avoid these situations happen. The double buffer concept is to flash TC2C during TC2 counting, to set the new value to TC2R (reload buffer), and the new value will be loaded from TC2R to TC2C after TC2 overflow occurrence automatically. In the next cycle, the TC2 timer runs under new conditions, and no any transitions occur. The auto-reload function is no any control interface and always actives as TC2 enables. If TC2 timer interrupt function is enabled (TC2IEN=1), the system will execute interrupt procedure. The interrupt procedure is system program counter points to interrupt vector (ORG 0008H) and executes interrupt service routine after TC2 overflow occurrence. Clear TC2IRQ by program is necessary in interrupt procedure. TC2 timer can works in normal mode, slow mode and green mode. Under green mode, TC2 keep counting, set TC2IRQ and outputs PWM, can't wake-up system.

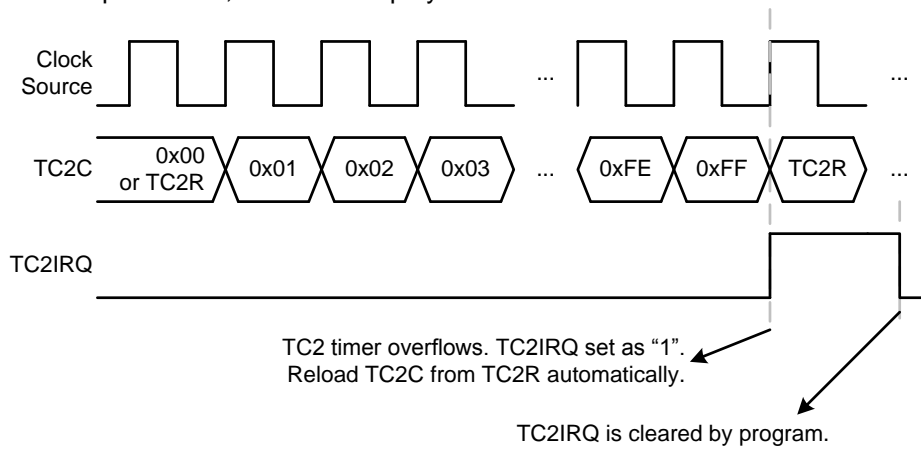

TC2 provides different clock sources to implement different applications and configurations. TC2 clock source includes Fhosc (high speed oscillator), Fosc (low speed RC oscillator) controlled by FCLKMD bit. If FCLKMD=0, TC2 clock source is Fhosc through TC2rate[2:0] pre-scalar to decide Fosc/1~Fosc/128. If FCLKMD=1, TC2 clock source is Fosc through TC2rate[2:0] pre-scalar to decide Fosc/1~Fosc/128. TC2 length is 8-bit (256 steps), and the one count period is each cycle of input clock.

CLKMD	TC2rate[2:0]	TC2 Clock	TC2 Interval Time			
			Fhosc=16MHz, Fcpu=Fosc/4		Fhosc=4MHz, Fcpu=Fosc/4	
			max. (us)	Unit (us)	max. (us)	Unit (us)
0	000b	Fosc/128	2048	8	8192	32
0	001b	Fosc/64	1024	4	4096	16
0	010b	Fosc/32	512	2	2048	8
0	011b	Fosc/16	256	1	1024	4
0	100b	Fosc/8	128	0.5	512	2
0	101b	Fosc/4	64	0.25	256	1
0	110b	Fosc/2	32	0.125	128	0.5
0	111b	Fosc/1	16	0.0625	64	0.25
CLKMD	TC2rate[2:0]	TC2 Clock	TC2 Interval Time			
			Fosc=32KHz, Fcpu=Fosc/4		Fosc=16KHz, Fcpu=Fosc/4	
			max. (ms)	Unit (ms)	max. (ms)	Unit (ms)
1	000b	Fosc/128	1024	4	2048	8
1	001b	Fosc/64	512	2	1024	4
1	010b	Fosc/32	256	1	512	2
1	011b	Fosc/16	128	0.5	256	1
1	100b	Fosc/8	64	0.25	128	0.5
1	101b	Fosc/4	32	0.125	64	0.25
1	110b	Fosc/2	16	0.0625	32	0.125
1	111b	Fosc/1	8	0.03125	16	0.0625

8.4.14 TC2M MODE REGISTER

TC2M is TC2 timer mode control register to configure TC2 operating mode including TC2 pre-scaler, clock source, PWM function... These configurations must be setup completely before enabling TC2 timer.

0A4H	Bit 7	Bit 6	Bit 5	Bit 4	Bit 3	Bit 2	Bit 1	Bit 0
TC2M	TC2ENB	TC2rate2	TC2rate1	TC2rate0	-	-	TC2PO	PWM2OUT
Read/Write	R/W	R/W	R/W	R/W	-	-	R/W	R/W
After reset	0	0	0	0	-	-	0	0

- Bit 0 **PWM2OUT**: PWM output control bit.
0 = Disable PWM output function, and P2.0, P1.4 (controlled by PWCH[3:2] bits) are GPIO mode.
1 = Enable PWM output function, and P2.0, P1.4 (controlled by PWCH[3:2] bits) output PWM signal.
- Bit 1 **TC2PO**: TC2 pulse output function control bit.
0 = Disable TC2 pulse output function.
1 = Enable TC2 pulse output function.
- Bit [6:4] **TC2RATE[2:0]**: TC2 timer clock source select bits.
FCLKMD=0:
>> 000 = Fhosc/128, 001 = Fhosc/64, 010 = Fhosc/32, 011 = Fhosc/16, 100 = Fhosc/8, 101 = Fhosc/4, 110 = Fhosc/2, 111 = Fhosc/1.
FCLKMD=1:
>> 000 = Fosc/128, 001 = Fosc/64, 010 = Fosc/32, 011 = Fosc/16, 100 = Fosc/8, 101 = Fosc/4, 110 = Fosc/2, 111 = Fosc/1.
- Bit 7 **TC2ENB**: TC2 timer control bit.
0 = Disable TC2 timer.
1 = Enable TC2 timer.

8.4.15 TC2C COUNTING REGISTER

TC2C is TC2 8-bit counter. When TC2C overflow occurs, the TC2IRQ flag is set as "1" and cleared by program. The TC2C decides TC2 interval time through below equation to calculate a correct value. It is necessary to write the correct value to TC2C register and TC2R register first time, and then enable TC2 timer to make sure the first cycle correct. After one TC2 overflow occurs, the TC2C register is loaded a correct value from TC2R register automatically, not program.

0A5H	Bit 7	Bit 6	Bit 5	Bit 4	Bit 3	Bit 2	Bit 1	Bit 0
TC2C	TC2C7	TC2C6	TC2C5	TC2C4	TC2C3	TC2C2	TC2C1	TC2C0
Read/Write	R/W	R/W	R/W	R/W	R/W	R/W	R/W	R/W
After reset	0	0	0	0	0	0	0	0

The equation of TC2C initial value is as following.

$$TC2C \text{ initial value} = 256 - (TC2 \text{ interrupt interval time} * TC2 \text{ clock rate})$$

8.4.16 TC2R AUTO-RELOAD REGISTER

TC2 timer builds in auto-reload function, and TC2R register stores reload data. When TC2C overflow occurs, TC2C register is loaded data from TC2R register automatically. Under TC2 timer counting status, to modify TC2 interval time is to modify TC2R register, not TC2C register. New TC2C data of TC2 interval time will be updated after TC2 timer overflow occurrence, TC2R loads new value to TC2C register. But at the first time to setup TC2M, TC2C and TC2R must be set the same value before enabling TC2 timer. TC2 is double buffer design. If new TC2R value is set by program, the new value is stored in 1st buffer. Until TC2 overflow occurs, the new value moves to real TC2R buffer. This way can avoid any transitional condition to affect the correctness of TC2 interval time and PWM output signal.

0A6H	Bit 7	Bit 6	Bit 5	Bit 4	Bit 3	Bit 2	Bit 1	Bit 0
TC2R	TC2R7	TC2R6	TC2R5	TC2R4	TC2R3	TC2R2	TC2R1	TC2R0
Read/Write	W	W	W	W	W	W	W	W
After reset	0	0	0	0	0	0	0	0

The equation of TC2R initial value is as following.

$$TC2R \text{ initial value} = 256 - (TC2 \text{ interrupt interval time} * TC2 \text{ clock rate})$$

☞ **Example: To calculation TC2C and TC2R value to obtain 100us TC2 interval time. TC2 clock source is Fosc = 16MHz. Select TC2RATE = 011 (Fosc/16).**

TC2 interval time = 100us. TC2 clock rate = 16MHz/16

$$\begin{aligned}
 TC2C/TC2R \text{ initial value} &= 256 - (TC2 \text{ interval time} * \text{input clock}) \\
 &= 256 - (100us * 16MHz / 16) \\
 &= 256 - (100 * 10^{-6} * 16 * 10^6 / 16) \\
 &= 9CH
 \end{aligned}$$

8.4.17 TC2D PWM DUTY REGISTER

TC2D register's purpose is to decide PWM duty. In PWM mode, TC2R controls PWM's cycle, and TC2D controls the duty of PWM. The operation is base on timer counter value. When TC2C = TC2D, the PWM high duty finished and exchange to low level. It is easy to configure TC2D to choose the right PWM's duty for application.

0A7H	Bit 7	Bit 6	Bit 5	Bit 4	Bit 3	Bit 2	Bit 1	Bit 0
TC2D	TC2D7	TC2D6	TC2D5	TC2D4	TC2D3	TC2D2	TC2D1	TC2D0
Read/Write	R/W	R/W	R/W	R/W	R/W	R/W	R/W	R/W
After Reset	0	0	0	0	0	0	0	0

The equation of TC2D initial value is as following.

$$TC2D \text{ initial value} = TC2R + (PWM \text{ high pulse width period} / TC2 \text{ clock rate})$$

☞ **Example: To calculate TC2D value to obtain 1/3 duty PWM signal. The TC2 clock source is Fosc = 16MHz. Select TC2RATE=000 (Fosc/128).**

TC2R = 9CH. TC2 interval time = 800us. So the PWM cycle is 1.25KHz. In 1/3 duty condition, the high pulse width is about 267us.

$$\begin{aligned}
 TC2D \text{ initial value} &= 9CH + (PWM \text{ high pulse width period} / TC2 \text{ clock rate}) \\
 &= 9CH + (267us * 16MHz / 128) \\
 &= 9CH + 21H \\
 &= BDH
 \end{aligned}$$

8.4.18 PULSE WIDTH MODULATION (PWM)

The PWM is duty/cycle programmable design to offer various PWM signals. When TC2 timer enables before, PWM2OUT bit sets as “1” (enable PWM output) and select PWM output pin (PWCH[3:2]), the PWM output pin (P2.0, P1.4) outputs PWM signal. **The PWM output signal needs time to synchronize in normal mode and slow mode, so designer should be very carefully to process the synchronous timing and the first PWM duty cycle must be correct. When output PWM function, we must be set PWM2OUT=1 first and then set TC2ENB=1 or PWM duty cycle will be error. When PWM output signal synchronize finishes, the PWM channel exchanges from GPIO to PWM output. When TC2ENB = 0 or PWM2OUT = 0, the PWM channel returns to GPIO mode and last status.** One cycle of PWM signal is high pulse first, and then low pulse outputs. TC2R register controls the cycle of PWM, and TC2D decides the duty (high pulse width length) of PWM. TC2C initial value is TC2R reloaded when TC2 timer enables and TC2 timer overflows. When TC2C count is equal to TC2D, the PWM high pulse finishes and exchanges to low level. When TC2 overflows (TC2C counts from 0xFF to 0x00), one complete PWM cycle finishes. The PWM exchanges to high level for next cycle. The PWM is auto-reload design to load TC2C from TC2R automatically when TC2 overflows and the end of PWM’s cycle, to keeps PWM continuity. If modify the PWM duty/cycle by program as PWM outputting, the new cycle occurs at next cycle when TC2C loaded from TC2R. The PWM channels selected by PWCH[3:2] bits. PWM20, PWM21 output pin is P2.0, P1.4. The PWM20, PWM21 output pins are shared with GPIO pin controlled by PWCH[3:2] bits.

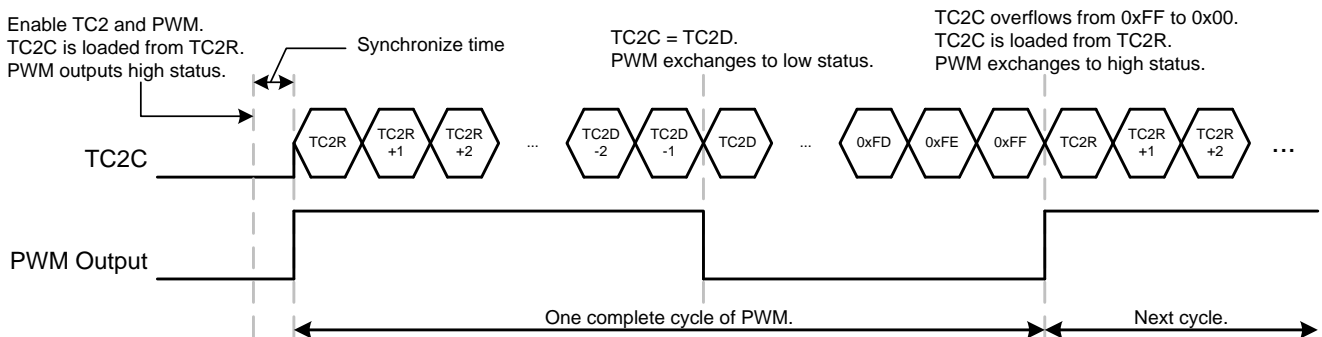

PWM output synchronous + Delay time table:

		Normal Mode		Slow Mode	
		STPHX=0	STPHX=1	STPHX=0	STPHX=1
TC2 clock source	Fhosc	$< (1/F_{hosc} + TC2RATE/F_{hosc})$	X	X	X
	Ffosc	X	X	$< (1/F_{fosc} + TC2RATE/F_{fosc})$	$< (1/F_{fosc} + TC2RATE/F_{fosc})$

PWM stops output and back to GPIO mode’s delay time table:

PWES	TC2PO	PWM control bit	TC2 clock source	Normal Mode		Slow Mode	
				STPHX=0	STPHX=1	STPHX=0	STPHX=1
0	0	PWM2OUT = 1→0	Fhosc	immediately	X	X	X
			Ffosc	X	X	immediately	immediately
0	0	TC2ENB = 1→0	Fhosc	immediately	X	X	X
			Ffosc	X	X	immediately	immediately
0	1	PWM2OUT = 1→0 (Auto setting)	Fhosc	immediately (PWM Low level finished)	X	X	X
			Ffosc	X	X	immediately (PWM Low level finished)	immediately (PWM Low level finished)
01~11	0	PWM2OUT = 1→0	Fhosc	immediately	X	X	X
			Ffosc	X	X	immediately	immediately
		TC2ENB = 1→0	Fhosc	immediately	X	X	X

The resolution of PWM is decided by TC2R. TC2R range is from 0x00~0xFF. If TC2R = 0x00, PWM’s resolution is 1/256. If TC2R = 0x80, PWM’s resolution is 1/128. TC2D controls the high pulse width of PWM for PWM’s duty. When TC2C = TC2D, PWM output exchanges to low status. TC2D must be greater than TC2R, or the PWM signal keeps low status. When PWM outputs, TC2IRQ still actives as TC2 overflows, and TC2 interrupt function actives as TC2IEN = 1. But strongly recommend be careful to use PWM and TC2 timer together, and make sure both functions work well. The PWM output pin is shared with GPIO and switch to output PWM signal as PWM2OUT=1 automatically. If PWM2OUT bit is cleared to disable PWM, the output pin exchanges to last GPIO mode automatically. It easily to implement carry signal on/off operation, not to control TC2ENB bit.

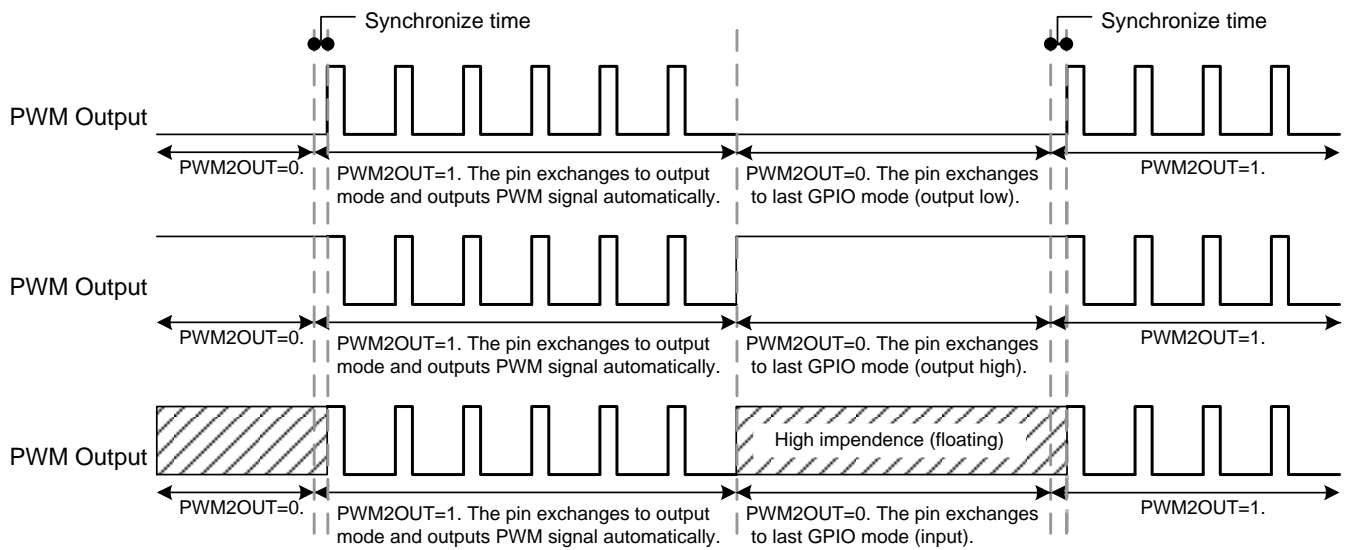

ACH	Bit 7	Bit 6	Bit 5	Bit 4	Bit 3	Bit 2	Bit 1	Bit 0
PWCH			PWCH31	PWCH30	PWCH21	PWCH20	PWCH11	PWCH10
Read/Write			R/W	R/W	R/W	R/W	R/W	R/W
After Reset			0	0	0	0	0	0

Bit 3 **PWCH21**: PWM21 control bit.
0 = P1.4 pin GPIO mode.
1 = PWM21 output.

Bit 2 **PWCH20**: PWM20 control bit.
0 = P2.0 pin GPIO mode.
1 = PWM20 output.

DEH	Bit 7	Bit 6	Bit 5	Bit 4	Bit 3	Bit 2	Bit 1	Bit 0
PWES			PW3ES1	PW3ES0	PW2ES1	PW2ES0	PW1ES1	PW1ES0
Read/Write			R/W	R/W	R/W	R/W	R/W	R/W
After Reset			0	0	0	0	0	0

Bit [3:2] **PW2ES[1:0]**: The PWM2 output with extension control bits (**One pulse PWM function doesn't support**).
00: None compensation.
01: Compensation 1 count at phase 1 of TC2 PWM output.
10: Compensation 1 count at phase 1/3 of TC2 PWM output.
11: Compensation 1 count at phase 1/2/3 of TC2 PWM output.

- If TC2ENB = PWM2OUT = 1 and PWCH[3:2] = 0, PWM doesn't output and P2.0, P1.4 still GPIO mode.
- PWM includes 2-channel selected through PWCH[3:2] bits. If the related bits of PWCH[3:2] are enabled, the related pin outputs PWM signal. If the bit is disabled, the pin returns to last GPIO mode.
- If PWM output with extension function enable first, then disable (TC2ENB=0), and enable (TC2ENB=1), 4-phase PWM 2-bit counter will be reset.

8.4.19 2-Channel PWM

The GPIO mode of 2-channel PWM output pins can be the idle status of PWM signal. PWM high idle status is GPIO output high mode. PWM low idle status is GPIO output low mode. PWM high impedance idle status is GPIO input mode. Select a right "PWM" idle status is very important for loading control as PWM disable. The PWM signal is generated from internal PWM processor and outputs to external pin (P2.0, P1.4) through PWCH[3:2] bits channel selections. **If the related bits of PWCH[3:2] are enabled, the related pin outputs PWM signal. If the bit is disabled, the pin returns to last GPIO mode.** The PWM signal of internal source and external pins are the same. The channel selections only switch PWM channels and not process the phase of PWM signal.

8.4.20 One Pulse PWM

When TC2PO = 0, TC2 is normal timer mode or PWM function mode. When TC2PO = 1 and PWM2OUT=1, TC2 will output one pulse PWM function. **One pulse PWM function output signal needs time to synchronize in normal mode and slow mode. So designer should be very carefully to process the synchronous timing.** When one pulse PWM output signal synchronize finishes, the PWM channel exchanges from GPIO to PWM output. When one pulse PWM output finishes, PWM2OUT bit is cleared automatically, the PWM channel returns to GPIO mode and last status. TC2IRQ is issued as TC2 counter overflow. To output next pulse is to set PWM2OUT bit by program again. One pulse PWM channels selected by PWCH[3:2] bits. PWM20, PWM21 output pin is P2.0, P1.4. The PWM20, PWM21 output pins are shared with GPIO pin controlled by PWCH[3:2] bits.

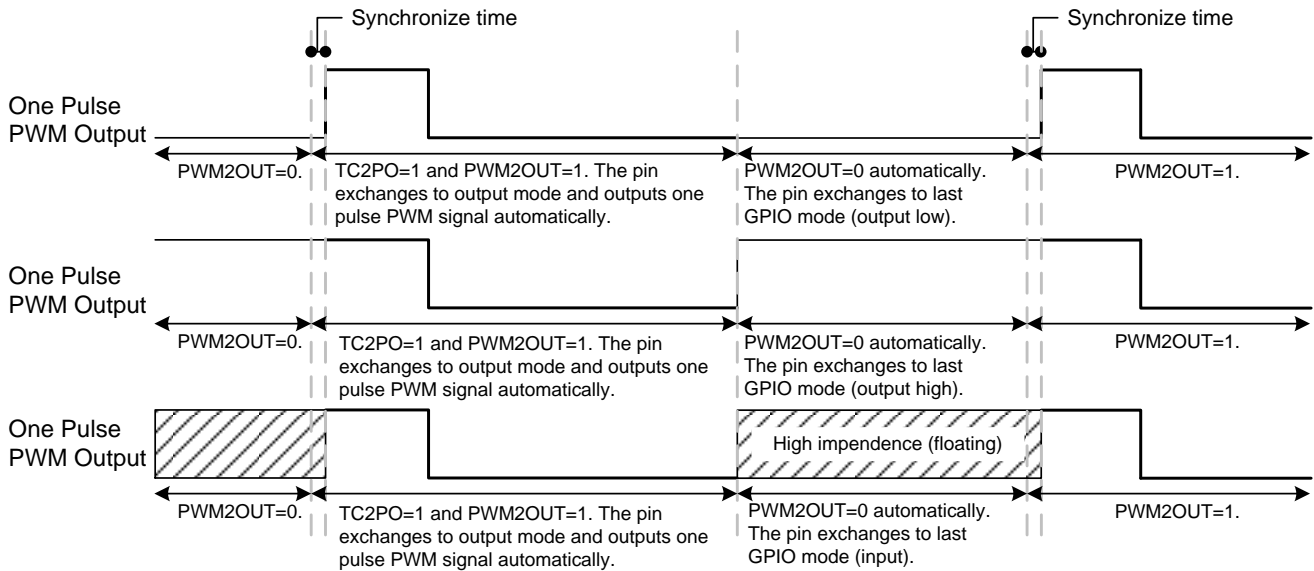

8.4.21 PWM output with Extension function

The PWM extension function supports TC2 PWM function only. One pulse PWM function doesn't support PWM extension function. The PWM extension function controlled by PWES[3:2] bits. If PWES[3:2] = 00, PWM extension function is none compensation. The PWM extension function compensates high level status period at low width of duty cycle. **The PWM with extension function is four phases design. One cycle of PWM with extension function is combined from four sub-cycle signals.** The duty of PWM with extension function is placed in each of sub-cycle. The duty output sequence of the four phases is a special design and through PWM phase processor to allot the duty to each phase. The PWM output with extension function designs auto-reload function. If modify the PWES[3:2] by program as PWM outputting, the new PWM with extension function occurs at next cycle and not change immediately. The methods can avoid the transitional duty occurrence. The PWM output with extension function compensate phase1~phase3 at TC2C from 254 to 255 cont instantaneous. The compensate phase time is one count (TC2C is from 255 to overflow: 1 count period time). If user modify PWES[3:2] bits, the new PWM will be change after current 4-phase PWM cycle finished.

TC2C = TC2R = 244, TC2D = 250, High width = 6, Low width = 6, PWM output.

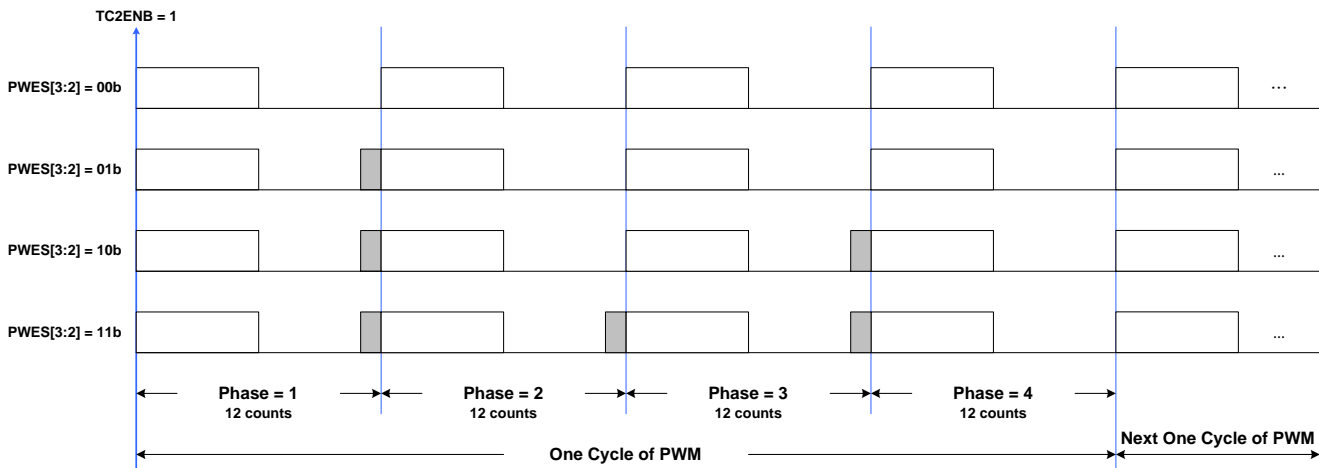

: Compensation 1 count.

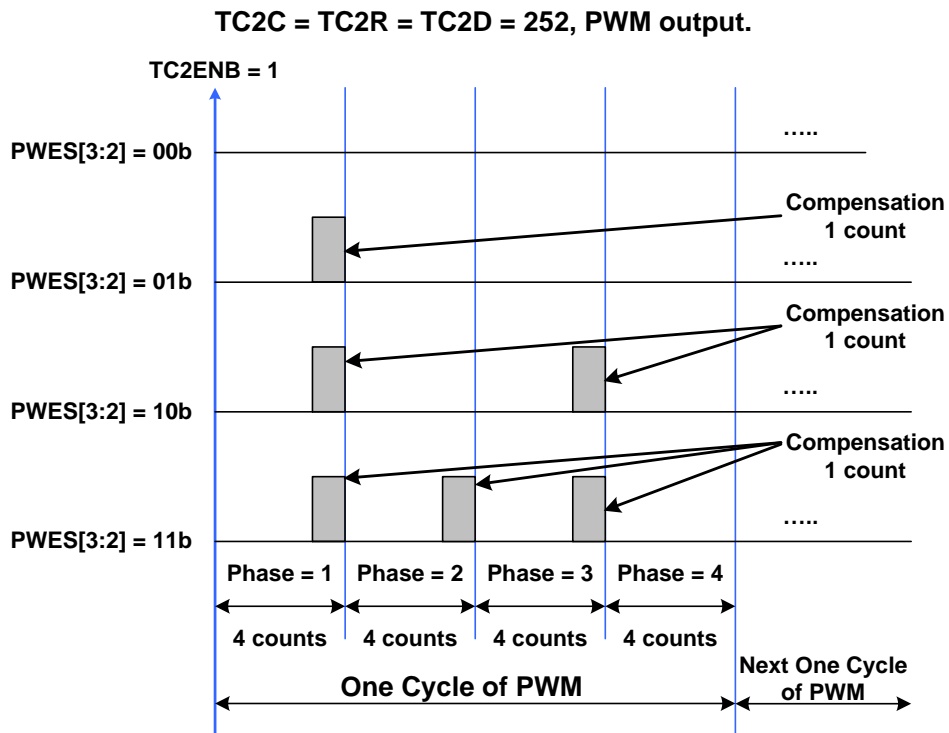

: Compensation 1 count.

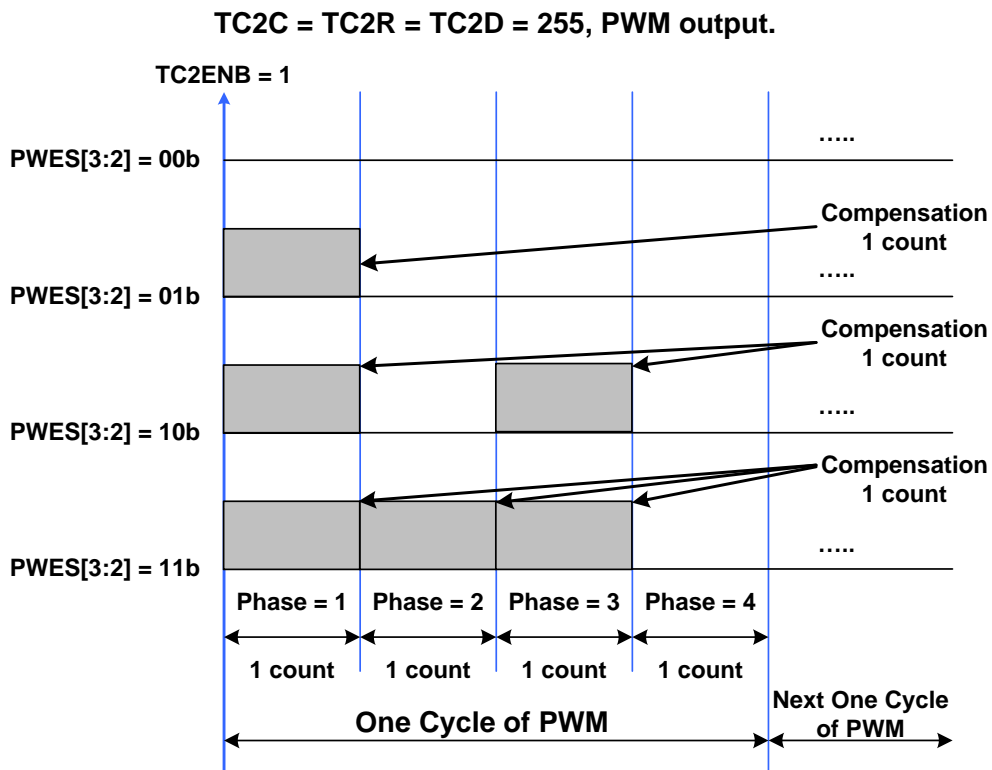

: Compensation 1 count.

8.4.22 TC2 TIMER OPERATION EXAMPLE

● TC2 TIMER CONFIGURATION:

; Reset TC2 timer.

```
CLR          TC2M          ; Clear TC2M register.
```

; Set TC2 clock source and TC2 rate.

```
MOV          A, #0nnn0000b
B0MOV       TC2M, A
```

; Set TC2C and TC2R register for TC2 Interval time.

```
MOV          A, #value      ; TC2C must be equal to TC2R.
B0MOV       TC2C, A
B0MOV       TC2R, A
```

; Clear TC2IRQ

```
B0BCLR      FTC2IRQ
```

; Enable TC2 timer and interrupt function.

```
B0BSET      FTC2IEN        ; Enable TC2 interrupt function.
B0BSET      FTC2ENB        ; Enable TC2 timer.
```

● TC2 PWM CONFIGURATION:

; Reset TC2 timer.

```
CLR          TC2M          ; Clear TC2M register.
```

; Set TC2 clock source and TC2 rate.

```
MOV          A, #0nnn0000b
B0MOV       TC2M, A
```

; Set TC2C and TC2R register for PWM cycle.

```
MOV          A, #value1     ; TC2C must be equal to TC2R.
B0MOV       TC2C, A
B0MOV       TC2R, A
```

; Set TC2D register for PWM duty.

```
MOV          A, #value2     ; TC2D must be greater than TC2R.
B0MOV       TC2D, A
```

; Set PWM channel.

```
MOV          A, #0000nn00b
B0MOV       PWCH, A
```

; Enable PWM and TC2 timer.

```
B0BSET      FPWM2OUT       ; Enable PWM.
B0BSET      FTC2ENB        ; Enable TC2 timer.
```

- **TC2 One Pulse PWM CONFIGURATION:**

```

; Reset TC2 timer.
      CLR          TC2M          ; Clear TC2M register.

; Set TC2 clock source and TC2 rate.
      MOV          A, #0nnn0000b
      B0MOV       TC2M, A

; Set TC2C and TC2R register for PWM cycle.
      MOV          A, #value1    ; TC2C must be equal to TC2R.
      B0MOV       TC2C, A
      B0MOV       TC2R, A

; Set TC2D register for PWM duty.
      MOV          A, #value2    ; TC2D must be greater than TC2R.
      B0MOV       TC2D, A

; Set PWM channel.
      MOV          A, #0000nn00b
      B0MOV       PWCH, A

; Enable PWM and TC2 timer.
      B0BSET      FTC2PO        ; Enable One Pulse.
      B0BSET      FPWM2OUT     ; Enable PWM.
      B0BSET      FTC2ENB      ; Enable TC2 timer.

```

- **TC2 PWM WITH EXTENSION CONFIGURATION:**

```

; Reset TC2 timer.
      CLR          TC2M          ; Clear TC2M register.

; Set TC2 clock source and TC2 rate.
      MOV          A, #0nnn0000b
      B0MOV       TC2M, A

; Set TC2C and TC2R register for PWM cycle.
      MOV          A, #value1    ; TC2C must be equal to TC2R.
      B0MOV       TC2C, A
      B0MOV       TC2R, A

; Set TC2D register for PWM duty.
      MOV          A, #value2    ; TC2D must be greater than TC2R.
      B0MOV       TC2D, A

; Set PWM channel and Extension.
      MOV          A, #0000nn00b
      B0MOV       PWCH, A
      MOV          A, #0000nn00b
      B0MOV       PWES, A

; Enable PWM and TC2 timer.
      B0BSET      FPWM2OUT     ; Enable PWM.
      B0BSET      FTC2ENB      ; Enable TC2 timer.

```

8.5 TC3 8-BIT TIMER/COUNTER

8.5.1 OVERVIEW

The TC3 timer is an 8-bit binary up timer with basic timer, PWM, One Pulse PWM and PWM with extension functions. The basic timer function supports flag indicator (TC3IRQ bit) and interrupt operation (interrupt vector). The interval time is programmable through TC3M, TC3C, TC3R registers. The event counter is changing TC3 clock source from system clock (Fhosc/Fosc) to external clock like signal (e.g. continuous pulse, R/C type oscillating signal...). TC3 becomes a counter to count external clock number to implement measure application. TC3 also builds in duty/cycle programmable PWM. The PWM cycle and resolution are controlled by TC3 timer clock rate, TC3R and TC3D registers. So the PWM with good flexibility to implement IR carry signal, motor control and brightness adjuster.... TC3 PWM function also supports one pulse output signal that means only output one cycle PWM signal, not continuous. The PWM has two programmable channels shared with GPIO pins and controlled by PWCH[5:4] bit. The output operation must be through enabled each bit/channel of PWCH[5:4] bits. The enabled PWM channel exchanges from GPIO to PWM output. When the PWCH[5:4] bits disables, the PWM channel returns to GPIO mode and last status. And support the 2-channel PWM output with extension selected by PWES[5:4] bits. TC3 counter supports auto-reload function which always enabled. When TC3 timer overflow occurs, the TC3C will be reloaded from TC3R automatically. The auto-reload function is always enabled. The TC3 doesn't build in green mode wake-up function.

The main purposes of the TC3 timer are as following.

- ☞ **8-bit programmable up counting timer:** Generate time-out at specific time intervals based on the selected clock frequency.
- ☞ **Interrupt function:** TC3 timer function supports interrupt function. When TC3 timer occurs overflow, the TC3IRQ actives and the system points program counter to interrupt vector to do interrupt sequence.
- ☞ **Duty/cycle programmable PWM:** The PWM is duty/cycle programmable controlled by TC3R and TC3D registers.
- ☞ **One Pulse PWM:** The one pulse PWM is controlled by TC3PO bit. When TC3PO=0, TC3 is normal timer mode or PWM function mode. When TC3PO=1, TC3 is one pulse PWM function. When PWMOUT=1, one pulse PWM outputs and the TC3IRQ is issued as TC3 counter overflow, PWMOUT bit is cleared automatically, the PWM channel returns to GPIO mode and last status. **One Pulse PWM doesn't support extension function (PWES[5:4]).**
- ☞ **2-Channel PWM output:** The 2-channel PWM output are controlled by PWCH[5:4] bits.
- ☞ **PWM output with Extension function: The PWM with extension function is four phases design.** The PWM output with extension function are controlled by PWES[5:4] bits.
- ☞ **Green mode function:** All TC3 functions (timer, PWM, event counter, auto-reload, extension) keeps running in green mode, but no wake-up function. Timer IRQ actives as any IRQ trigger occurrence, e.g. timer overflow...

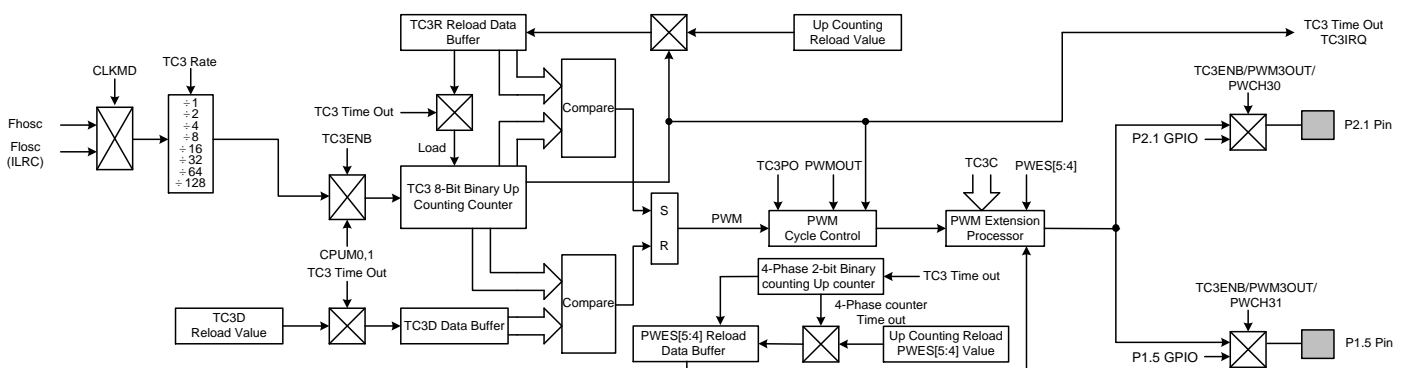

8.5.2 TC3 TIMER OPERATION

TC3 timer is controlled by TC3ENB bit. When TC3ENB=0, TC3 timer stops. When TC3ENB=1, TC3 timer starts to count. Before enabling TC3 timer, setup TC3 timer's configurations to select timer function modes, e.g. basic timer, interrupt function...TC3C increases "1" by timer clock source. When TC3 overflow event occurs, TC3IRQ flag is set as "1" to indicate overflow and cleared by program. The overflow condition is TC3C count from full scale (0xFF) to zero scale (0x00). In difference function modes, TC3C value relates to operation. If TC3C value changing effects operation, the transition of operations would make timer function error. So TC3 builds in double buffer to avoid these situations happen. The double buffer concept is to flash TC3C during TC3 counting, to set the new value to TC3R (reload buffer), and the new value will be loaded from TC3R to TC3C after TC3 overflow occurrence automatically. In the next cycle, the TC3 timer runs under new conditions, and no any transitions occur. The auto-reload function is no any control interface and always actives as TC3 enables. If TC3 timer interrupt function is enabled (TC3IEN=1), the system will execute interrupt procedure. The interrupt procedure is system program counter points to interrupt vector (ORG 0008H) and executes interrupt service routine after TC3 overflow occurrence. Clear TC3IRQ by program is necessary in interrupt procedure. TC3 timer can works in normal mode, slow mode and green mode. Under green mode, TC3 keep counting, set TC3IRQ and outputs PWM, can't wake-up system.

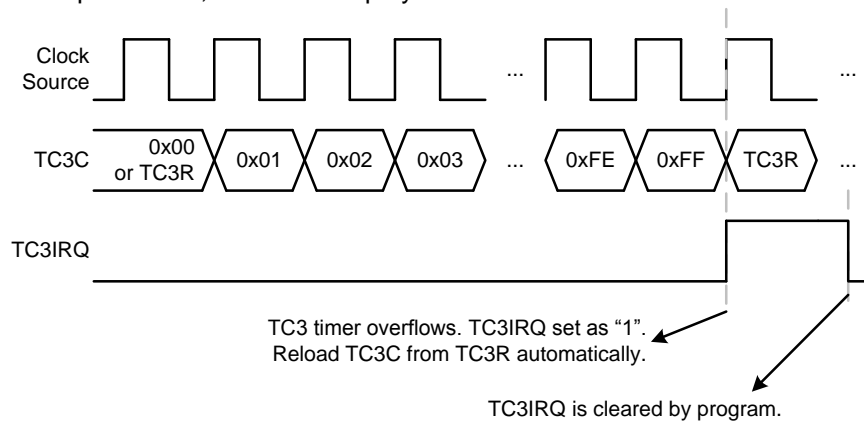

TC3 provides different clock sources to implement different applications and configurations. TC3 clock source includes Fhosc (high speed oscillator), Fosc (low speed RC oscillator) controlled by FCLKMD bit. If FCLKMD=0, TC3 clock source is Fhosc through TC3rate[2:0] pre-scalar to decide Fosc/1~Fosc/128. If FCLKMD=1, TC3 clock source is Fosc through TC3rate[2:0] pre-scalar to decide Fosc/1~Fosc/128. TC3 length is 8-bit (256 steps), and the one count period is each cycle of input clock.

CLKMD	TC3rate[2:0]	TC3 Clock	TC3 Interval Time			
			Fhosc=16MHz, Fcpu=Fosc/4		Fhosc=4MHz, Fcpu=Fosc/4	
			max. (us)	Unit (us)	max. (us)	Unit (us)
0	000b	Fosc/128	2048	8	8192	32
0	001b	Fosc/64	1024	4	4096	16
0	010b	Fosc/32	512	2	2048	8
0	011b	Fosc/16	256	1	1024	4
0	100b	Fosc/8	128	0.5	512	2
0	101b	Fosc/4	64	0.25	256	1
0	110b	Fosc/2	32	0.125	128	0.5
0	111b	Fosc/1	16	0.0625	64	0.25
CLKMD	TC3rate[2:0]	TC3 Clock	TC3 Interval Time			
			Fosc=32KHz, Fcpu=Fosc/4		Fosc=16KHz, Fcpu=Fosc/4	
			max. (ms)	Unit (ms)	max. (ms)	Unit (ms)
1	000b	Fosc/128	1024	4	2048	8
1	001b	Fosc/64	512	2	1024	4
1	010b	Fosc/32	256	1	512	2
1	011b	Fosc/16	128	0.5	256	1
1	100b	Fosc/8	64	0.25	128	0.5
1	101b	Fosc/4	32	0.125	64	0.25
1	110b	Fosc/2	16	0.0625	32	0.125
1	111b	Fosc/1	8	0.03125	16	0.0625

8.5.3 TC3M MODE REGISTER

TC3M is TC3 timer mode control register to configure TC3 operating mode including TC3 pre-scalar, clock source, PWM function... These configurations must be setup completely before enabling TC3 timer.

0A8H	Bit 7	Bit 6	Bit 5	Bit 4	Bit 3	Bit 2	Bit 1	Bit 0
TC3M	TC3ENB	TC3rate2	TC3rate1	TC3rate0	-	-	TC3PO	PWM3OUT
Read/Write	R/W	R/W	R/W	R/W	-	-	R/W	R/W
After reset	0	0	0	0	-	-	0	0

- Bit 0 **PWM3OUT:** PWM output control bit.
0 = Disable PWM output function, and P2.1, P1.5 (controlled by PWCH[5:4] bits) are GPIO mode.
1 = Enable PWM output function, and P2.1, P1.5 (controlled by PWCH[5:4] bits) output PWM signal.
- Bit 1 **TC3PO:** TC3 pulse output function control bit.
0 = Disable TC3 pulse output function.
1 = Enable TC3 pulse output function.
- Bit [6:4] **TC3RATE[2:0]:** TC3 timer clock source select bits.
FCLKMD=0:
>> 000 = Fhosc/128, 001 = Fhosc/64, 010 = Fhosc/32, 011 = Fhosc/16, 100 = Fhosc/8, 101 = Fhosc/4,
110 = Fhosc/2, 111 = Fhosc/1.
FCLKMD=1:
>> 000 = Fosc/128, 001 = Fosc/64, 010 = Fosc/32, 011 = Fosc/16, 100 = Fosc/8, 101 = Fosc/4, 110 =
Fosc/2, 111 = Fosc/1.
- Bit 7 **TC3ENB:** TC3 timer control bit.
0 = Disable TC3 timer.
1 = Enable TC3 timer.

8.5.4 TC3C COUNTING REGISTER

TC3C is TC3 8-bit counter. When TC3C overflow occurs, the TC3IRQ flag is set as "1" and cleared by program. The TC3C decides TC3 interval time through below equation to calculate a correct value. It is necessary to write the correct value to TC3C register and TC3R register first time, and then enable TC3 timer to make sure the first cycle correct. After one TC3 overflow occurs, the TC3C register is loaded a correct value from TC3R register automatically, not program.

0A9H	Bit 7	Bit 6	Bit 5	Bit 4	Bit 3	Bit 2	Bit 1	Bit 0
TC3C	TC3C7	TC3C6	TC3C5	TC3C4	TC3C3	TC3C2	TC3C1	TC3C0
Read/Write	R/W	R/W	R/W	R/W	R/W	R/W	R/W	R/W
After reset	0	0	0	0	0	0	0	0

The equation of TC3C initial value is as following.

$$TC3C \text{ initial value} = 256 - (TC3 \text{ interrupt interval time} * TC3 \text{ clock rate})$$

8.5.5 TC3R AUTO-RELOAD REGISTER

TC3 timer builds in auto-reload function, and TC3R register stores reload data. When TC3C overflow occurs, TC3C register is loaded data from TC3R register automatically. Under TC3 timer counting status, to modify TC3 interval time is to modify TC3R register, not TC3C register. New TC3C data of TC3 interval time will be updated after TC3 timer overflow occurrence, TC3R loads new value to TC3C register. But at the first time to setup TC3M, TC3C and TC3R must be set the same value before enabling TC3 timer. TC3 is double buffer design. If new TC3R value is set by program, the new value is stored in 1st buffer. Until TC3 overflow occurs, the new value moves to real TC3R buffer. This way can avoid any transitional condition to affect the correctness of TC3 interval time and PWM output signal.

0AAH	Bit 7	Bit 6	Bit 5	Bit 4	Bit 3	Bit 2	Bit 1	Bit 0
TC3R	TC3R7	TC3R6	TC3R5	TC3R4	TC3R3	TC3R2	TC3R1	TC3R0
Read/Write	W	W	W	W	W	W	W	W
After reset	0	0	0	0	0	0	0	0

The equation of TC3R initial value is as following.

$$TC3R \text{ initial value} = 256 - (TC3 \text{ interrupt interval time} * TC3 \text{ clock rate})$$

☞ **Example: To calculation TC3C and TC3R value to obtain 100us TC3 interval time. TC3 clock source is Fosc = 16MHz. Select TC3RATE = 011 (Fosc/16).**
TC3 interval time = 100us. TC3 clock rate = 16MHz/16

$$\begin{aligned} TC3C/TC3R \text{ initial value} &= 256 - (TC3 \text{ interval time} * \text{input clock}) \\ &= 256 - (100\mu s * 16\text{MHz} / 16) \\ &= 256 - (100 * 10^{-6} * 16 * 10^6 / 16) \\ &= 9CH \end{aligned}$$

8.5.6 TC3D PWM DUTY REGISTER

TC3D register's purpose is to decide PWM duty. In PWM mode, TC3R controls PWM's cycle, and TC3D controls the duty of PWM. The operation is base on timer counter value. When TC3C = TC3D, the PWM high duty finished and exchange to low level. It is easy to configure TC3D to choose the right PWM's duty for application.

0ABH	Bit 7	Bit 6	Bit 5	Bit 4	Bit 3	Bit 2	Bit 1	Bit 0
TC3D	TC3D7	TC3D6	TC3D5	TC3D4	TC3D3	TC3D2	TC3D1	TC3D0
Read/Write	R/W	R/W	R/W	R/W	R/W	R/W	R/W	R/W
After Reset	0	0	0	0	0	0	0	0

The equation of TC3D initial value is as following.

$$TC3D \text{ initial value} = TC3R + (PWM \text{ high pulse width period} / TC3 \text{ clock rate})$$

☞ **Example: To calculate TC3D value to obtain 1/3 duty PWM signal. The TC3 clock source is Fosc = 16MHz. Select TC3RATE=000 (Fosc/128).**
TC3R = 9CH. TC3 interval time = 800us. So the PWM cycle is 1.25KHz. In 1/3 duty condition, the high pulse width is about 267us.

$$\begin{aligned} TC3D \text{ initial value} &= 9CH + (PWM \text{ high pulse width period} / TC3 \text{ clock rate}) \\ &= 9CH + (267\mu s * 16\text{MHz} / 128) \\ &= 9CH + 21H \\ &= BDH \end{aligned}$$

8.5.7 PULSE WIDTH MODULATION (PWM)

The PWM is duty/cycle programmable design to offer various PWM signals. When TC3 timer enables before, PWM3OUT bit sets as “1” (enable PWM output) and select PWM output pin (PWCH[5:4]), the PWM output pin (P2.1, P1.5) outputs PWM signal. **The PWM output signal needs time to synchronize in normal mode and slow mode, so designer should be very carefully to process the synchronous timing and the first PWM duty cycle must be correct. When output PWM function, we must be set PWM3OUT=1 first and then set TC3ENB=1 or PWM duty cycle will be error. When PWM output signal synchronize finishes, the PWM channel exchanges from GPIO to PWM output. When TC3ENB = 0 or PWM3OUT = 0, the PWM channel returns to GPIO mode and last status.** One cycle of PWM signal is high pulse first, and then low pulse outputs. TC3R register controls the cycle of PWM, and TC3D decides the duty (high pulse width length) of PWM. TC3C initial value is TC3R reloaded when TC3 timer enables and TC3 timer overflows. When TC3C count is equal to TC3D, the PWM high pulse finishes and exchanges to low level. When TC3 overflows (TC3C counts from 0xFF to 0x00), one complete PWM cycle finishes. The PWM exchanges to high level for next cycle. The PWM is auto-reload design to load TC3C from TC3R automatically when TC3 overflows and the end of PWM’s cycle, to keeps PWM continuity. If modify the PWM duty/cycle by program as PWM outputting, the new cycle occurs at next cycle when TC3C loaded from TC3R. The PWM channels selected by PWCH[5:4] bits. PWM30, PWM31 output pin is P2.1, P1.5. The PWM30, PWM31 output pins are shared with GPIO pin controlled by PWCH[5:4] bits.

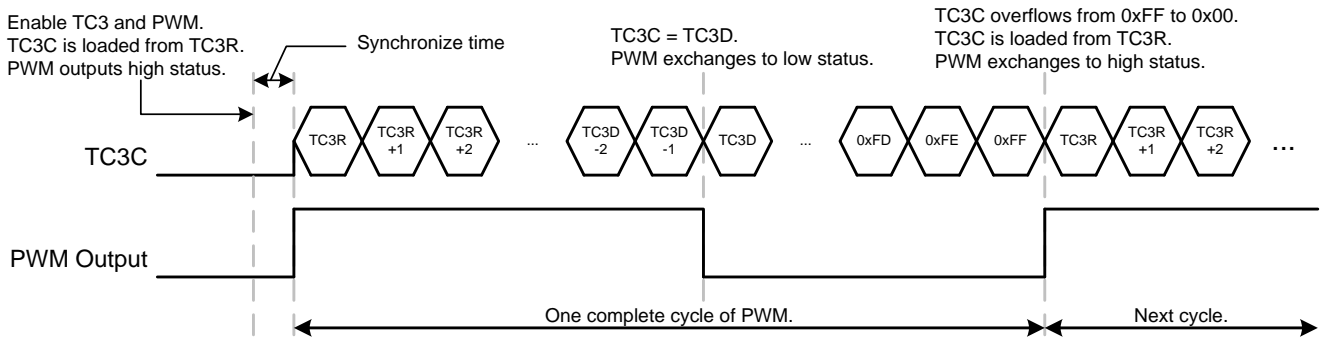

PWM output synchronous + Delay time table:

		Normal Mode		Slow Mode	
		STPHX=0	STPHX=1	STPHX=0	STPHX=1
TC3 clock source	Fhosc	$< (1/Fhosc + TC3RATE/Fhosc)$	X	X	X
	Ffosc	X	X	$< (1/Ffosc + TC3RATE/Ffosc)$	$< (1/Ffosc + TC3RATE/Ffosc)$

PWM stops output and back to GPIO mode’s delay time table:

PWES	TC3PO	PWM control bit	TC3 clock source	Normal Mode		Slow Mode	
				STPHX=0	STPHX=1	STPHX=0	STPHX=1
0	0	PWM3OUT = 1→0	Fhosc	immediately	X	X	X
			Ffosc	X	X	immediately	immediately
0	0	TC3ENB = 1→0	Fhosc	immediately	X	X	X
			Ffosc	X	X	immediately	immediately
0	1	PWM3OUT = 1→0 (Auto setting)	Fhosc	immediately (PWM Low level finished)	X	X	X
			Ffosc	X	X	immediately (PWM Low level finished)	immediately (PWM Low level finished)
01~11	0	PWM3OUT = 1→0	Fhosc	immediately	X	X	X
			Ffosc	X	X	immediately	immediately
		TC3ENB = 1→0	Fhosc	immediately	X	X	X

The resolution of PWM is decided by TC3R. TC3R range is from 0x00~0xFF. If TC3R = 0x00, PWM’s resolution is 1/256. If TC3R = 0x80, PWM’s resolution is 1/128. TC3D controls the high pulse width of PWM for PWM’s duty. When TC3C = TC3D, PWM output exchanges to low status. TC3D must be greater than TC3R, or the PWM signal keeps low status. When PWM outputs, TC3IRQ still actives as TC3 overflows, and TC3 interrupt function actives as TC3IEN = 1. But strongly recommend be careful to use PWM and TC3 timer together, and make sure both functions work well. The PWM output pin is shared with GPIO and switch to output PWM signal as PWM3OUT=1 automatically. If PWM3OUT bit is cleared to disable PWM, the output pin exchanges to last GPIO mode automatically. It easily to implement carry signal on/off operation, not to control TC3ENB bit.

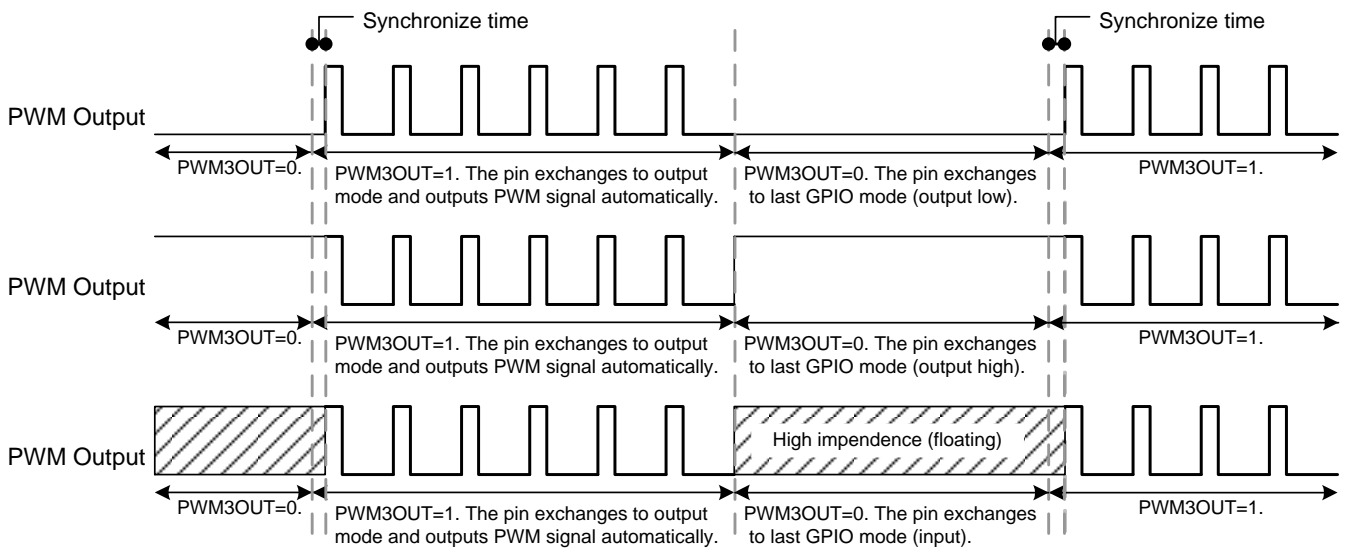

ACH	Bit 7	Bit 6	Bit 5	Bit 4	Bit 3	Bit 2	Bit 1	Bit 0
PWCH			PWCH31	PWCH30	PWCH21	PWCH20	PWCH11	PWCH10
Read/Write			R/W	R/W	R/W	R/W	R/W	R/W
After Reset			0	0	0	0	0	0

Bit 5 **PWCH31**: PWM31 control bit.
0 = P1.5 pin GPIO mode.
1 = PWM31 output.

Bit 4 **PWCH30**: PWM30 control bit.
0 = P2.1 pin GPIO mode.
1 = PWM30 output.

DEH	Bit 7	Bit 6	Bit 5	Bit 4	Bit 3	Bit 2	Bit 1	Bit 0
PWES			PW3ES1	PW3ES0	PW2ES1	PW2ES0	PW1ES1	PW1ES0
Read/Write			R/W	R/W	R/W	R/W	R/W	R/W
After Reset			0	0	0	0	0	0

Bit [5:4] **PW3ES[1:0]**: The PWM3 output with extension control bits (**One pulse PWM function doesn't support**).
00: None compensation.
01: Compensation 1 count at phase 1 of TC3 PWM output.
10: Compensation 1 count at phase 1/3 of TC3 PWM output.
11: Compensation 1 count at phase 1/2/3 of TC3 PWM output.

- If $TC3ENB = PWM3OUT = 1$ and $PWCH[5:4] = 0$, PWM doesn't output and P2.1, P1.5 still GPIO mode.
- PWM includes 2-channel selected through $PWCH[5:4]$ bits. If the related bits of $PWCH[5:4]$ are enabled, the related pin outputs PWM signal. If the bit is disabled, the pin returns to last GPIO mode.
- If PWM output with extension function enable first, then disable ($TC3ENB=0$), and enable ($TC3ENB=1$), 4-phase PWM 2-bit counter will be reset.

8.5.8 2-Channel PWM

The GPIO mode of 2-channel PWM output pins can be the idle status of PWM signal. PWM high idle status is GPIO output high mode. PWM low idle status is GPIO output low mode. PWM high impedance idle status is GPIO input mode. Select a right "PWM" idle status is very important for loading control as PWM disable. The PWM signal is generated from internal PWM processor and outputs to external pin (P2.1, P1.5) through $PWCH[5:4]$ bits channel selections. **If the related bits of $PWCH[5:4]$ are enabled, the related pin outputs PWM signal. If the bit is disabled, the pin returns to last GPIO mode.** The PWM signal of internal source and external pins are the same. The channel selections only switch PWM channels and not process the phase of PWM signal.

8.5.9 One Pulse PWM

When TC3PO = 0, TC3 is normal timer mode or PWM function mode. When TC3PO = 1 and PWM3OUT=1, TC3 will output one pulse PWM function. **One pulse PWM function output signal needs time to synchronize in normal mode and slow mode. So designer should be very carefully to process the synchronous timing.** When one pulse PWM output signal synchronize finishes, the PWM channel exchanges from GPIO to PWM output. When one pulse PWM output finishes, PWM3OUT bit is cleared automatically, the PWM channel returns to GPIO mode and last status. TC3IRQ is issued as TC3 counter overflow. To output next pulse is to set PWM3OUT bit by program again. One pulse PWM channels selected by PWCH[5:4] bits. PWM30, PWM31 output pin is P2.1, P1.5. The PWM30, PWM31 output pins are shared with GPIO pin controlled by PWCH[5:4] bits.

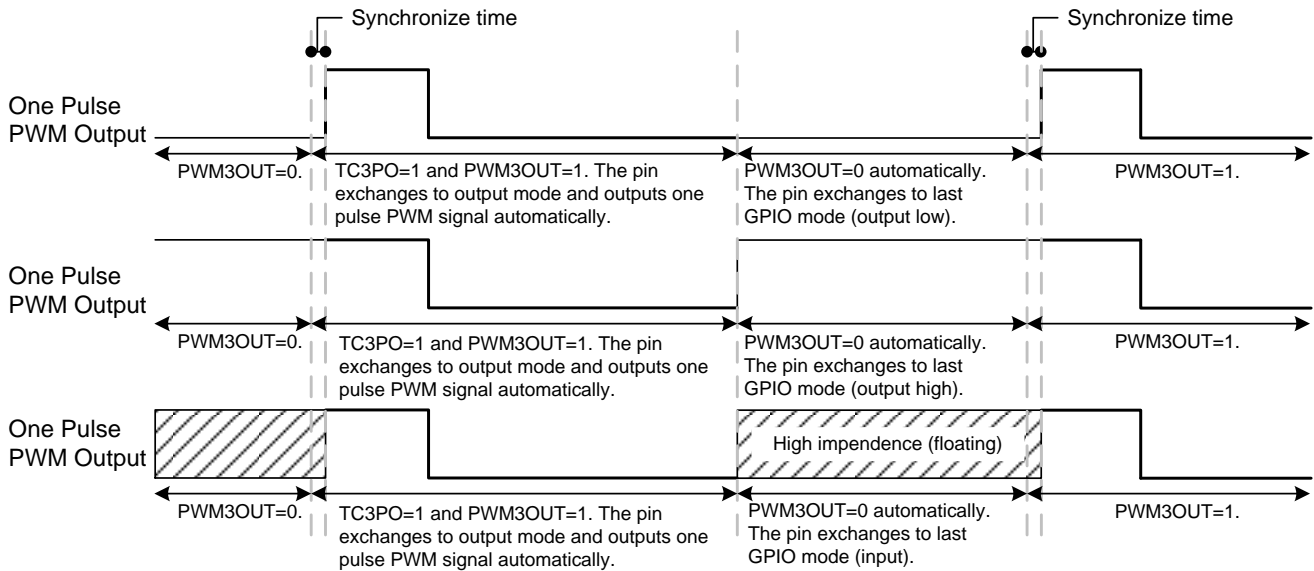

8.5.10 PWM output with Extension function

The PWM extension function supports TC3 PWM function only. One pulse PWM function doesn't support PWM extension function. The PWM extension function controlled by PWES[5:4] bits. If PWES[5:4] = 00, PWM extension function is none compensation. The PWM extension function compensates high level status period at low width of duty cycle. **The PWM with extension function is four phases design. One cycle of PWM with extension function is combined from four sub-cycle signals.** The duty of PWM with extension function is placed in each of sub-cycle. The duty output sequence of the four phases is a special design and through PWM phase processor to allot the duty to each phase. The PWM output with extension function designs auto-reload function. If modify the PWES[5:4] by program as PWM outputting, the new PWM with extension function occurs at next cycle and not change immediately. The methods can avoid the transitional duty occurrence. The PWM output with extension function compensate phase1~phase3 at TC3C from 254 to 255 cont instantaneous. The compensate phase time is one count (TC3C is from 255 to overflow: 1 count period time). If user modify PWES[5:4] bits, the new PWM will be change after current 4-phase PWM cycle finished.

TC3C = TC3R = 244, TC3D = 250, High width = 6, Low width = 6, PWM output.

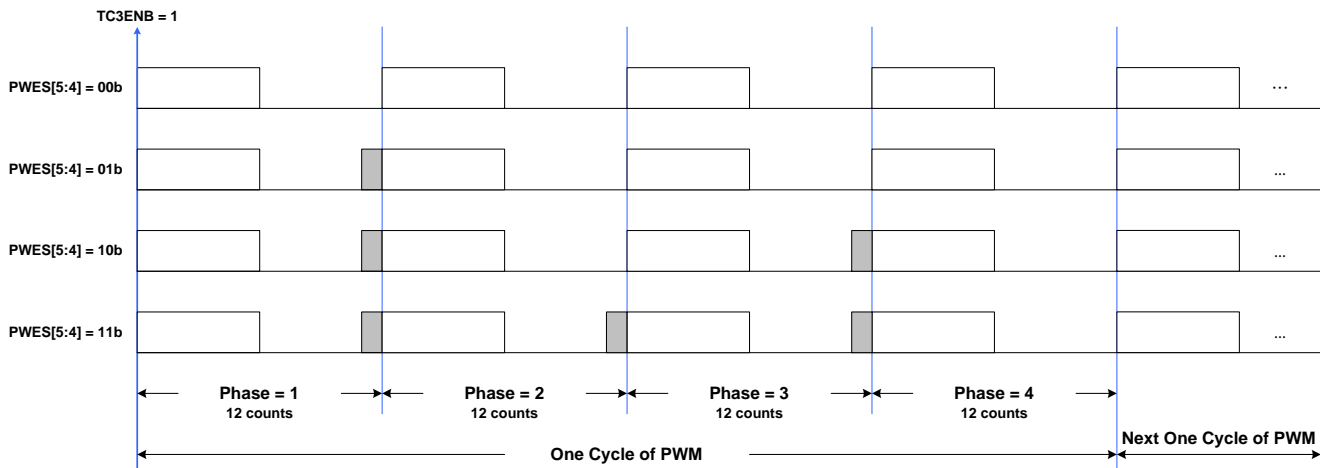

: Compensation 1 count.

TC3C = TC3R = TC3D = 252, PWM output.

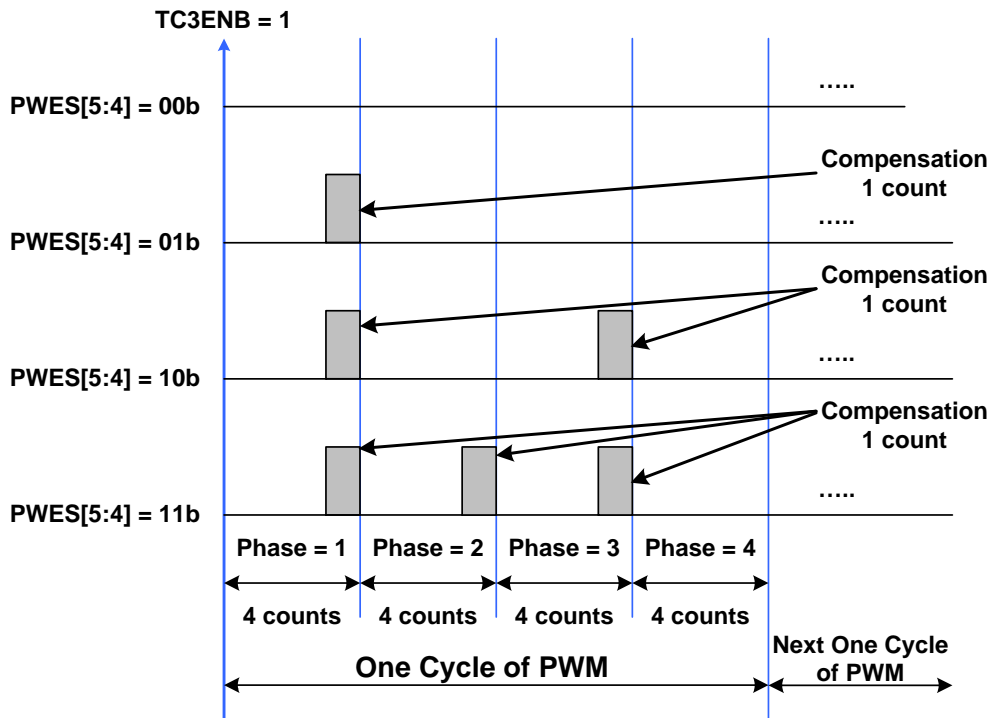

: Compensation 1 count.

TC3C = TC3R = TC3D = 255, PWM output.

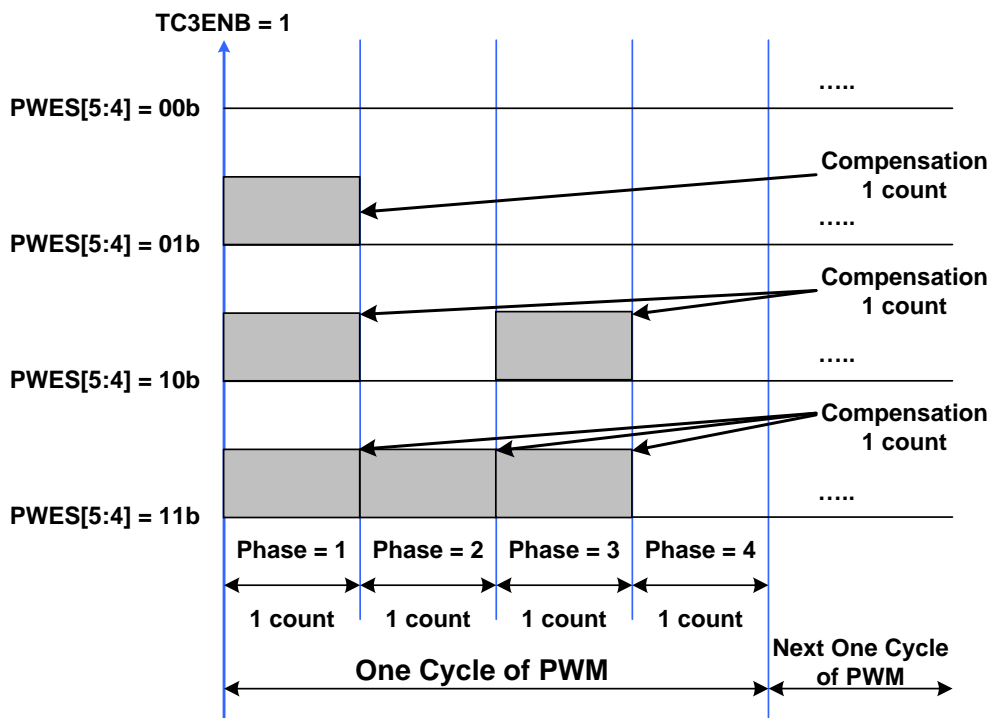

: Compensation 1 count.

8.5.11 TC3 TIMER OPERATION EXAMPLE

● TC3 TIMER CONFIGURATION:

; Reset TC3 timer.

```
CLR          TC3M          ; Clear TC3M register.
```

; Set TC3 clock source and TC3 rate.

```
MOV          A, #0nnn0000b
B0MOV       TC3M, A
```

; Set TC3C and TC3R register for TC3 Interval time.

```
MOV          A, #value      ; TC3C must be equal to TC3R.
B0MOV       TC3C, A
B0MOV       TC3R, A
```

; Clear TC3IRQ

```
B0BCLR      FTC3IRQ
```

; Enable TC3 timer and interrupt function.

```
B0BSET      FTC3IEN        ; Enable TC3 interrupt function.
B0BSET      FTC3ENB        ; Enable TC3 timer.
```

● TC3 PWM CONFIGURATION:

; Reset TC3 timer.

```
CLR          TC3M          ; Clear TC3M register.
```

; Set TC3 clock source and TC3 rate.

```
MOV          A, #0nnn0000b
B0MOV       TC3M, A
```

; Set TC3C and TC3R register for PWM cycle.

```
MOV          A, #value1     ; TC3C must be equal to TC3R.
B0MOV       TC3C, A
B0MOV       TC3R, A
```

; Set TC3D register for PWM duty.

```
MOV          A, #value2     ; TC3D must be greater than TC3R.
B0MOV       TC3D, A
```

; Set PWM channel.

```
MOV          A, #00nn0000b
B0MOV       PWCH, A
```

; Enable PWM and TC3 timer.

```
B0BSET      FPWM3OUT       ; Enable PWM.
B0BSET      FTC3ENB        ; Enable TC3 timer.
```

- **TC3 One Pulse PWM CONFIGURATION:**

; Reset TC3 timer.

```
CLR          TC3M          ; Clear TC3M register.
```

; Set TC3 clock source and TC3 rate.

```
MOV          A, #0nnn0000b
BO MOV       TC3M, A
```

; Set TC3C and TC3R register for PWM cycle.

```
MOV          A, #value1    ; TC3C must be equal to TC3R.
BO MOV       TC3C, A
BO MOV       TC3R, A
```

; Set TC3D register for PWM duty.

```
MOV          A, #value2    ; TC3D must be greater than TC3R.
BO MOV       TC3D, A
```

; Set PWM channel.

```
MOV          A, #00nn0000b
BO MOV       PWCH, A
```

; Enable PWM and TC3 timer.

```
BO BSET      FTC3PO        ; Enable One Pulse.
BO BSET      FPWM3OUT      ; Enable PWM.
BO BSET      FTC3ENB       ; Enable TC3 timer.
```

- **TC3 PWM WITH EXTENSION CONFIGURATION:**

; Reset TC3 timer.

```
CLR          TC3M          ; Clear TC3M register.
```

; Set TC3 clock source and TC3 rate.

```
MOV          A, #0nnn0000b
BO MOV       TC3M, A
```

; Set TC3C and TC3R register for PWM cycle.

```
MOV          A, #value1    ; TC3C must be equal to TC3R.
BO MOV       TC3C, A
BO MOV       TC3R, A
```

; Set TC3D register for PWM duty.

```
MOV          A, #value2    ; TC3D must be greater than TC3R.
BO MOV       TC3D, A
```

; Set PWM channel and Extension.

```
MOV          A, #00nn0000b
BO MOV       PWCH, A
MOV          A, #00nn0000b
BO MOV       PWES, A
```

; Enable PWM and TC3 timer.

```
BO BSET      FPWM3OUT      ; Enable PWM.
BO BSET      FTC3ENB       ; Enable TC3 timer.
```

9 12 CHANNEL ANALOG TO DIGITAL CONVERTER (ADC)

9.1 OVERVIEW

The analog to digital converter (ADC) is SAR structure with 12-input sources and up to 4096-step resolution to transfer analog signal into 12-bits digital buffers. The ADC builds in 12-channel input source (AIN0~AIN11) to measure 12 different analog signal sources controlled by CHS[3:0] and GCHS bits. The ADC resolution can be selected 8-bit and 12-bit resolutions through ADLEN bit. The ADC converting rate can be selected by ADCKS[1:0] bits to decide ADC converting time. The ADC reference high voltage includes 4 sources controlled by VREFH register. Three internal power source including Vdd, 3.5V and 2.5V. The other one is external reference voltage input pin from P4.0 pin. The ADC builds in P1CON/P4CON registers to set pure analog input pin. It is necessary to set ADC input pin as input mode without pull-up resistor by program. After setup ADENB and ADS bits, the ADC starts to convert analog signal to digital data. When the conversion is complete, the ADC circuit will set EOC and ADCIRQ bits to "1" and the digital data outputs in ADB and ADR registers. If the ADCIEN = 1, the ADC interrupt request occurs and executes interrupt service routine when ADCIRQ = 1 after ADC converting. If ADC interrupt function is enabled (ADCIEN=1), the system will execute interrupt procedure. The interrupt procedure is system program counter points to interrupt vector (ORG 8) and executes interrupt service routine after ADC converting. Clear ADCIRQ by program is necessary in interrupt procedure. ADC can work in green mode. After ADC operating, the system would be waked up from green mode to last mode (normal mode/slow mode).

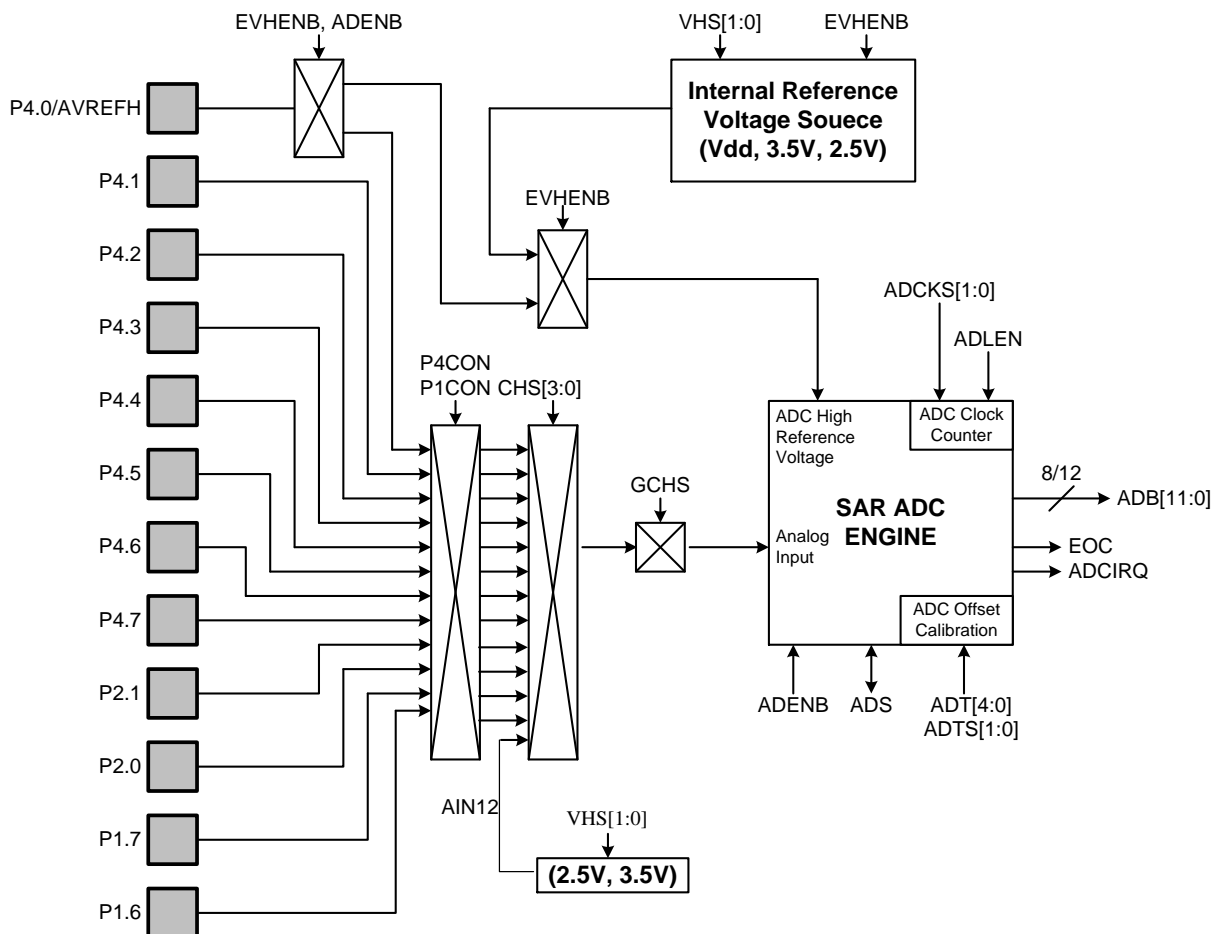

9.2 ADC MODE REGISTER

ADM is ADC mode control register to configure ADC configurations including ADC start, ADC channel selection, ADC high reference voltage source and ADC processing indicator...These configurations must be setup completely before starting ADC converting.

0B1H	Bit 7	Bit 6	Bit 5	Bit 4	Bit 3	Bit 2	Bit 1	Bit 0
ADM	ADENB	ADS	EOC	GCHS	CHS3	CHS2	CHS1	CHS0
Read/Write	R/W	R/W	R/W	R/W	R/W	R/W	R/W	R/W
After reset	0	0	0	0	0	0	0	0

Bit 7 **ADENB**: ADC control bit. **In power saving mode, disable ADC to reduce power consumption.**

0 = Disable ADC function.
1 = Enable ADC function.

Bit 6 **ADS**: ADC start control bit. **ADS bit is cleared after ADC processing automatically.**

0 = ADC converting stops.
1 = Start to execute ADC converting.

Bit 5 **EOC**: ADC status bit.

0 = ADC progressing.
1 = End of converting and reset ADS bit.

Bit 4 **GCHS**: ADC global channel select bit.

0 = Disable AIN channel.
1 = Enable AIN channel.

Bit [3:0] **CHS[3:0]**: ADC input channel select bit.

0000 = AIN0, 0001 = AIN1, 0010 = AIN2, 0011 = AIN3, 0100 = AIN4, 0101 = AIN5, 0110 = AIN6,
0111 = AIN7, 1000 = AIN8, 1001 = AIN9, 1010 = AIN10, 1011 = AIN11, 1100 = AIN12,
1101 ~ 1111= Reserved.

The AIN12 is internal 2.5V or 3.5V input channel. There is no any input pin from outside. In this time ADC reference voltage must be internal VDD and External voltage not internal 2.5V or 3.5V. AIN12 can be a good battery detector for battery system. To select appropriate internal AVREFH level and compare value, a high performance and cheaper low battery detector is built in the system.

ADR register includes ADC mode control and ADC low-nibble data buffer. ADC configurations including ADC clock rate and ADC resolution. These configurations must be setup completely before starting ADC converting.

0B3H	Bit 7	Bit 6	Bit 5	Bit 4	Bit 3	Bit 2	Bit 1	Bit 0
ADR	-	ADCKS1	ADLEN	ADCKS0	ADB3	ADB2	ADB1	ADB0
Read/Write	-	R/W	R/W	R/W	R	R	R	R
After reset	-	0	0	0	-	-	-	-

Bit 6,4 **ADCKS [1:0]**: ADC's clock rate select bit.

00 = Fhosc/16, 01 = Fhosc/8, 10 = Fhosc/4, 11 = Fhosc/2

Bit 5 **ADLEN**: ADC's resolution select bits.

0 = 8-bit.
1 = 12-bit.

9.3 ADC DATA BUFFER REGISTERS

ADC data buffer is 12-bit length to store ADC converter result. The high byte is ADB register, and the low-nibble is ADR[3:0] bits. The ADB register is only 8-bit register including bit 4~bit11 ADC data. To combine ADB register and the low-nibble of ADR will get full 12-bit ADC data buffer. The ADC data buffer is a read-only register and the initial status is unknown after system reset.

- **ADB[11:4]:** In 8-bit ADC mode, the ADC data is stored in ADB register.
- **ADB[11:0]:** In 12-bit ADC mode, the ADC data is stored in ADB and ADR registers.

0B2H	Bit 7	Bit 6	Bit 5	Bit 4	Bit 3	Bit 2	Bit 1	Bit 0
ADB	ADB11	ADB10	ADB9	ADB8	ADB7	ADB6	ADB5	ADB4
Read/Write	R	R	R	R	R	R	R	R
After reset	-	-	-	-	-	-	-	-

Bit[7:0] **ADB[7:0]:** 8-bit ADC data buffer and the high-byte data buffer of 12-bit ADC.

0B3H	Bit 7	Bit 6	Bit 5	Bit 4	Bit 3	Bit 2	Bit 1	Bit 0
ADR	-	ADCKS1	ADLEN	ADCKS0	ADB3	ADB2	ADB1	ADB0
Read/Write	-	R/W	R/W	R/W	R	R	R	R
After reset	-	0	0	0	-	-	-	-

Bit [3:0] **ADB [3:0]:** 12-bit low-nibble ADC data buffer.

The AIN input voltage v.s. ADB output data

AIN n	ADB11	ADB10	ADB9	ADB8	ADB7	ADB6	ADB5	ADB4	ADB3	ADB2	ADB1	ADB0
0/4096*VREFH	0	0	0	0	0	0	0	0	0	0	0	0
1/4096*VREFH	0	0	0	0	0	0	0	0	0	0	0	1
.
.
4094/4096*VREFH	1	1	1	1	1	1	1	1	1	1	1	0
4095/4096*VREFH	1	1	1	1	1	1	1	1	1	1	1	1

For different applications, users maybe need more than 8-bit resolution but less than 12-bit. To process the ADB and ADR data can make the job well. First, the ADC resolution must be set 12-bit mode and then to execute ADC converter routine. Then delete the LSB of ADC data and get the new resolution result. The table is as following.

ADC Resolution	ADB								ADR			
	ADB11	ADB10	ADB9	ADB8	ADB7	ADB6	ADB5	ADB4	ADB3	ADB2	ADB1	ADB0
8-bit	0	0	0	0	0	0	0	0	x	x	x	x
9-bit	0	0	0	0	0	0	0	0	0	x	x	x
10-bit	0	0	0	0	0	0	0	0	0	0	x	x
11-bit	0	0	0	0	0	0	0	0	0	0	0	x
12-bit	0	0	0	0	0	0	0	0	0	0	0	0

0 = Selected. X = Useless.

* **Note:** The initial status of ADC data buffer including ADB register and ADR low-nibble after the system reset is unknown.

9.4 ADC REFERENCE VOLTQAGE REGISTERS

ADC builds in four high reference voltage source controlled through VREFH register. There are one external voltage source and three internal voltage source (VDD, 3.5V, 2.5V). When EVHENB bit is "1", ADC reference voltage is external voltage source from P4.0. It is necessary to input a voltage to be ADC high reference voltage and not below 2V. If EVHENB bit is "0", ADC reference voltage is from internal voltage source selected by VHS[1:0] bits. If VHS[1:0] is "11" or "10", ADC reference voltage is VDD. If VHS[1:0] is "01", ADC reference voltage is 3.5V. If VHS[1:0] is "00", ADC reference voltage is 2.5V. The limitation of internal reference voltage application is VDD can't below each of internal voltage level, or the level is equal to VDD.

0B0H	Bit 7	Bit 6	Bit 5	Bit 4	Bit 3	Bit 2	Bit 1	Bit 0
VREFH	EVHENB	-	-	-	-	-	VHS1	VHS0
Read/Write	R/W	-	-	-	-	-	R/W	R/W
After reset	0	-	-	-	-	-	0	0

Bit 7 **EVHENB**: ADC reference voltage control bit.
0 = ADC reference is internal reference voltage source, and P4.0 is GPIO/AIN0.
1 = ADC reference is external reference voltage source from P4.0.

Bit [1:0] **VHS[1:0]**: Internal reference voltage level selection.
11 = 10= Vdd. 01 = Internal 3.5V. 00 = Internal 2.5V.

* **Note: If AIN12 channel is selected as internal 2.5V or 3.5V input channel. There is no any input pin from outside. In this time ADC reference voltage must be internal VDD and External voltage, not internal 2.5V or 3.5V.**

9.5 ADC OPERATION DESCRIPTION AND NOTIC

9.5.1 ADC SIGNAL FORMAT

ADC sampling voltage range is limited by high/low reference voltage. The ADC low reference voltage is Vss and not changeable. The ADC high reference voltage includes internal Vdd/3.5V/2.5V and external reference voltage source from P4.0/AVREFH pin controlled by EVHENB bit. If EVHENB=0, ADC reference voltage is from internal voltage source. If EVHENB=1, ADC reference voltage is from external voltage source (P4.0/AVREFH). ADC reference voltage range limitation is "**(ADC high reference voltage – low reference voltage) ≥ 2V**". ADC low reference voltage is Vss = 0V. So **ADC high reference voltage range is 2V~Vdd**. The range is ADC external high reference voltage range.

- **ADC Internal Low Reference Voltage = 0V.**
- **ADC Internal High Reference Voltage = Vdd/3.5V/2.5V. (EVHENB=0)**
- **ADC External High Reference Voltage = 2V~Vdd. (EVHENB=1)**

ADC sampled input signal voltage must be from ADC low reference voltage to ADC high reference. If the ADC input signal voltage is over the range, the ADC converting result is error (full scale or zero).

- **ADC Low Reference Voltage ≤ ADC Sampled Input Voltage ≤ ADC High Reference Voltage**

9.5.2 ADC CONVERTING TIME

The ADC converting time is from ADS=1 (Start to ADC convert) to EOC=1 (End of ADC convert). The converting time duration is depend on ADC resolution and ADC clock rate. 12-bit ADC's converting time is $1/(\text{ADC clock}/4)*16$ sec, and the 8-bit ADC converting time is $1/(\text{ADC clock}/4)*12$ sec. ADC clock source is Fhosc and includes Fhosc/1, Fhosc/2, Fhosc/8 and Fhosc/16 controlled by ADCKS[1:0] bits.

The ADC converting time affects ADC performance. If input high rate analog signal, it is necessary to select a high ADC converting rate. If the ADC converting time is slower than analog signal variation rate, the ADC result would be error. So to select a correct ADC clock rate and ADC resolution to decide a right ADC converting rate is very important.

$$\text{12-bit ADC conversion time} = 1/(\text{ADC clock rate}/4)*16 \text{ sec}$$

ADLEN	ADCKS1, ADCKS0	ADC Clock Rate	Fhosc=4MHz		Fhosc=16MHz	
			ADC Converting time	ADC Converting Rate	ADC Converting time	ADC Converting Rate
1 (12-bit)	00	Fhosc/16	$1/(4\text{MHz}/16/4)*16$ = 256 us	3.906KHz	$1/(16\text{MHz}/16/4)*16$ = 64 us	15.625KHz
	01	Fhosc/8	$1/(4\text{MHz}/8/4)*16$ = 128 us	7.813KHz	$1/(16\text{MHz}/8/4)*16$ = 32 us	31.25KHz
	10	Fhosc	$1/(4\text{MHz}/4)*16$ = 16 us	62.5KHz	$1/(16\text{MHz}/4)*16$ = 4 us	250KHz
	11	Fhosc/2	$1/(4\text{MHz}/2/4)*16$ = 32 us	31.25KHz	$1/(16\text{MHz}/2/4)*16$ = 8 us	125KHz

$$\text{8-bit ADC conversion time} = 1/(\text{ADC clock rate}/4)*12 \text{ sec}$$

ADLEN	ADCKS1, ADCKS0	ADC Clock Rate	Fhosc=4MHz		Fhosc=16MHz	
			ADC Converting time	ADC Converting Rate	ADC Converting time	ADC Converting Rate
0 (8-bit)	00	Fhosc/16	$1/(4\text{MHz}/16/4)*12$ = 192 us	5.208KHz	$1/(16\text{MHz}/16/4)*12$ = 48 us	20.833KHz
	01	Fhosc/8	$1/(4\text{MHz}/8/4)*12$ = 96 us	10.416KHz	$1/(16\text{MHz}/8/4)*12$ = 24 us	41.667KHz
	10	Fhosc	$1/(4\text{MHz}/4)*12$ = 12 us	83.333KHz	$1/(16\text{MHz}/4)*12$ = 3 us	333.333KHz
	11	Fhosc/2	$1/(4\text{MHz}/2/4)*12$ = 24 us	41.667KHz	$1/(16\text{MHz}/2/4)*12$ = 6 us	166.667KHz

9.5.3 ADC PIN CONFIGURATION

ADC input channels are shared with Port1, Port2 and Port4. ADC channel selection is through CHS[3:0] bit. CHS[3:0] value points to the ADC input channel directly. CHS[3:0]=0000 selects AIN0. CHS[3:0]=0001 selects AIN1..... Only one pin of port4, port2 and port1 can be configured as ADC input in the same time. The pins of Port1, Port2 and Port4 configured as ADC input channel must be set input mode, disable internal pull-up and enable P4CON/P1CON first by program. After selecting ADC input channel through CHS[3:0], set GCHS bit as "1" to enable ADC channel function.

- The GPIO mode of ADC input channels must be set as input mode.
- The internal pull-up resistor of ADC input channels must be disabled.
- P1CON and P4CON bits of ADC input channel must be set.

The P4.0/AIN0 can be ADC external high reference voltage input pin when EVHENB=1. In the condition, P4.0 GPIO mode must be set as input mode and disable internal pull-up resistor.

- The GPIO mode of ADC external high reference voltage input pin must be set as input mode.
- The internal pull-up resistor of ADC external high reference voltage input pin must be disabled.

ADC input pins are shared with digital I/O pins. Connect an analog signal to COMS digital input pin, especially, the analog signal level is about 1/2 VDD will cause extra current leakage. In the power down mode, the above leakage current will be a big problem. Unfortunately, if users connect more than one analog input signal to port4, port2 or port1 will encounter above current leakage situation. P1CON is Port1 and Port2 configuration register. Write "1" into P1CON [7:6], [1:0] will configure related port 1, port2 pin as pure analog input pin to avoid current leakage. P4CON is Port4 configuration register. Write "1" into P4CON [7:0] will configure related port 4 pin as pure analog input pin to avoid current leakage.

0AEH	Bit 7	Bit 6	Bit 5	Bit 4	Bit 3	Bit 2	Bit 1	Bit 0
P4CON	P4CON7	P4CON6	P4CON5	P4CON4	P4CON3	P4CON2	P4CON1	P4CON0
Read/Write	W	W	W	W	W	W	W	W
After reset	0	0	0	0	0	0	0	0

Bit[7:0] **P4CON[7:0]**: P4.n configuration control bits.
 0 = P4.n can be an analog input (ADC input) or digital I/O pins.
 1 = P4.n is pure analog input, can't be a digital I/O pin.

0AFH	Bit 7	Bit 6	Bit 5	Bit 4	Bit 3	Bit 2	Bit 1	Bit 0
P1CON	P1CON7	P1CON6	-	-	-	-	P2CON1	P2CON0
Read/Write	W	W	-	-	-	-	W	W
After reset	0	0	-	-	-	-	0	0

Bit[7:6] **P1CON[7:6]**: P1.n configuration control bits.
 0 = P1.n can be an analog input (ADC input) or digital I/O pins.
 1 = P1.n is pure analog input, can't be a digital I/O pin.

Bit[1:0] **P2CON[1:0]**: P2.n configuration control bits.
 0 = P2.n can be an analog input (ADC input) or digital I/O pins.
 1 = P2.n is pure analog input, can't be a digital I/O pin.

* **Note: When ADC pin is general I/O mode, the bit of P1CON and P4CON must be set to "0", or the digital I/O signal would be isolated.**

9.6 ADC OPERATION EXAMLPE

● ADC CONFIGURATION:

; Reset ADC.

```
CLR          ADM          ; Clear ADM register.
```

; Set ADC clock rate and ADC resolution.

```
MOV          A, #0nmn0000b ; nn: ADCKS[1:0] for ADC clock rate.
BOBMOV      ADR, A         ; m: ADLEN for ADC resolution.
```

; Set ADC high reference voltage source.

```
BOBSET      FEVHENB       ; External reference voltage.
```

or

```
MOV          A, #000000nmb ; Internal Vdd.
BOBMOV      VREFH, A       ; "nn" select internal reference voltage level.
; 11 = 10 = VDD, 01 = 3.5V, 00 = 2.5V.
```

; Set ADC input channel configuration.

```
MOV          A, #value1    ; Set P4CON for ADC input channel.
BOBMOV      P4CON, A
MOV          A, #value2    ; Set ADC input channel as input mode.
BOBMOV      P4M, A
MOV          A, #value3    ; Disable ADC input channel's internal pull-up resistor.
BOBMOV      P4UR, A
```

```
MOV          A, #value4    ; Set P1CON for ADC input channel.
BOBMOV      P1CON, A
MOV          A, #value5    ; Set ADC input channel as input mode.
BOBMOV      P1M, A
MOV          A, #value6    ; Disable ADC input channel's internal pull-up resistor.
BOBMOV      P1UR, A
```

; Enable ADC.

```
BOBSET      FADCENB
```

; Execute ADC 100us warm-up time delay loop.

```
CALL        100usDLY      ; 100us delay loop.
```

; Select ADC input channel.

```
MOV          A, #value     ; Set CHS[3:0] for ADC input channel selection.
OR          ADM, A
```

; Enable ADC input channel.

```
BOBSET      FGCHS
```

; Enable ADC interrupt function.

```
BOBCLR      FADCIRQ       ; Clear ADC interrupt flag.
BOBSET      FADCIE        ; Enable ADC interrupt function.
```

; Start to execute ADC converting.

```
BOBSET      FADS
```

● **ADC AIN12 CONFIGURATION:**

; Reset ADC.

CLR ADM ; Clear ADM register.

; Set ADC clock rate and ADC resolution.

MOV A, #0nmn0000b ; nn: ADCKS[1:0] for ADC clock rate.
BO MOV ADR, A ; m: ADLEN for ADC resolution.

; Set ADC AIN12 input channel is 2.5V or 3.5V.

MOV A, #000000nmb ; "nn" select internal 2.5V or 3.5V input channel
BO MOV VREFH, A ; 00 = 2.5V, 01 = 3.5V.

; Set ADC high reference voltage source for detected.

BO BSET FEVHENB ; Detect external reference voltage.

or

BO BCLR FEVHENB ; Detect Internal Vdd.

; Select ADC input channel 12.

MOV A, #00001100b ; Set CHS[3:0] for ADC input channel selection.
OR ADM, A

; Enable ADC.

BO BSET FADCENB

; Execute ADC 100us warm-up time delay loop.

CALL 100usDLY ; 100us delay loop.

; Enable ADC input channel.

BO BSET FGCHS

; Enable ADC interrupt function.

BO BCLR FADCIRQ ; Clear ADC interrupt flag.
BO BSET FADCIE ; Enable ADC interrupt function.

; Start to execute ADC converting.

BO BSET FADS

* **Note:**

1. *When ADENB is enabled, the system must be delay 100us to be the ADC warm-up time by program, and then set ADS to do ADC converting. The 100us delay time is necessary after ADENB setting (not ADS setting), or the ADC converting result would be error. Normally, the ADENB is set one time when the system under normal run condition, and do the delay time only one time.*
2. *In power saving situation like power down mode and green mode, and not using ADC function, to disable ADC by program is necessary to reduce power consumption.*

● **ADC CONVERTING OPERATION:**; **ADC Interrupt disable mode.**

```

@@:
    BOBTS1    FEOC          ; Check ADC processing flag.
    JMP       @B           ; EOC=0: ADC is processing.
    B0MOV     A, ADB       ; EOC=1: End of ADC processing. Process ADC result.
    B0MOV     BUF1,A
    MOV       A, #00001111b
    AND      A, ADR
    B0MOV     BUF2,A
    ...
    CLR      FEOC         ; End of processing ADC result.
                          ; Clear ADC processing flag for next ADC converting.

```

; **ADC Interrupt enable mode.**

```

ORG 8          ; Interrupt vector.
INT_SR:       ; Interrupt service routine.

    BOBTS1    FADCIRQ      ; Check ADC interrupt flag.
    JMP       EXIT_INT    ; ADCIRQ=0: Not ADC interrupt request.
    B0MOV     A, ADB       ; ADCIRQ=1: End of ADC processing. Process ADC result.
    B0MOV     BUF1,A
    MOV       A, #00001111b
    AND      A, ADR
    B0MOV     BUF2,A
    ...
    CLR      FEOC         ; End of processing ADC result.
    JMP      INT_EXIT     ; Clear ADC processing flag for next ADC converting.

INT_EXIT:

    RETI          ; Exit interrupt service routine.

```

* **Note:** *ADS is cleared when the end of ADC converting automatically. EOC bit indicates ADC processing status immediately and is cleared when ADS = 1. Users needn't to clear it by program.*

9.7 ADC APPLICATION CIRCUIT

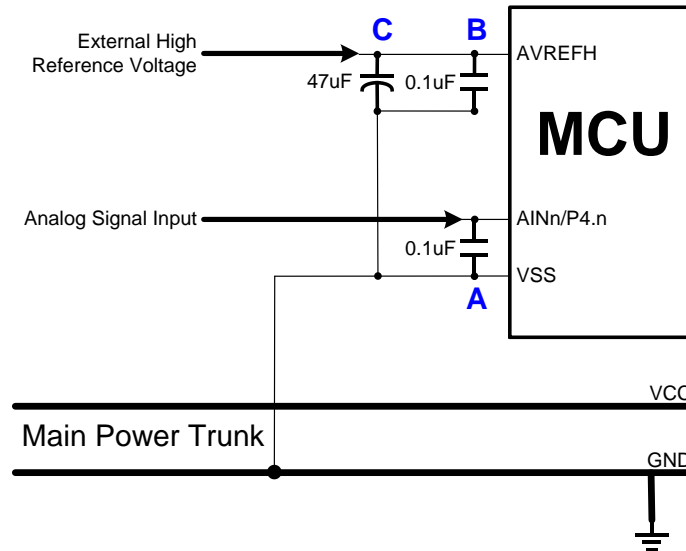

The analog signal is inputted to ADC input pin “AINn/P4.n” or “AINn/P2.n” or “AINn/P1.n”. The ADC input signal must be through a 0.1uF capacitor “A”. The 0.1uF capacitor is set between ADC input pin and VSS pin, and must be on the side of the ADC input pin as possible. Don’t connect the capacitor’s ground pin to ground plain directly, and must be through VSS pin. The capacitor can reduce the power noise effective coupled with the analog signal.

If the ADC high reference voltage is from external voltage source, the external high reference is connected to AVREFH pin (P4.0). The external high reference source must be through a 47uF “C” capacitor first, and then 0.1uF capacitor “B”. These capacitors are set between AVREFH pin and VSS pin, and must be on the side of the AVREFH pin as possible. Don’t connect the capacitor’s ground pin to ground plain directly, and must be through VSS pin.

10 INSTRUCTION TABLE

Field	Mnemonic	Description	C	DC	Z	Cycle
MOV	MOV A,M	$A \leftarrow M$	-	-	√	1
	MOV M,A	$M \leftarrow A$	-	-	-	1
	B0MOV A,M	$A \leftarrow M$ (bank 0)	-	-	√	1
	B0MOV M,A	M (bank 0) $\leftarrow A$	-	-	-	1
	MOV A,I	$A \leftarrow I$	-	-	-	1
	B0MOV M,I	$M \leftarrow I$, "M" only supports 0x80~0x87 registers (e.g. PFLAG,R,Y,Z...)	-	-	-	1
	XCH A,M	$A \leftrightarrow M$	-	-	-	1+N
	B0XCH A,M	$A \leftrightarrow M$ (bank 0)	-	-	-	1+N
	MOVC	$R, A \leftarrow ROM[Y,Z]$	-	-	-	2
ARITH	ADC A,M	$A \leftarrow A + M + C$, if occur carry, then $C=1$, else $C=0$	√	√	√	1
	ADC M,A	$M \leftarrow A + M + C$, if occur carry, then $C=1$, else $C=0$	√	√	√	1+N
	ADD A,M	$A \leftarrow A + M$, if occur carry, then $C=1$, else $C=0$	√	√	√	1
	ADD M,A	$M \leftarrow A + M$, if occur carry, then $C=1$, else $C=0$	√	√	√	1+N
	B0ADD M,A	M (bank 0) $\leftarrow M$ (bank 0) + A , if occur carry, then $C=1$, else $C=0$	√	√	√	1+N
	ADD A,I	$A \leftarrow A + I$, if occur carry, then $C=1$, else $C=0$	√	√	√	1
	SBC A,M	$A \leftarrow A - M - /C$, if occur borrow, then $C=0$, else $C=1$	√	√	√	1
	SBC M,A	$M \leftarrow A - M - /C$, if occur borrow, then $C=0$, else $C=1$	√	√	√	1+N
	SUB A,M	$A \leftarrow A - M$, if occur borrow, then $C=0$, else $C=1$	√	√	√	1
	SUB M,A	$M \leftarrow A - M$, if occur borrow, then $C=0$, else $C=1$	√	√	√	1+N
	SUB A,I	$A \leftarrow A - I$, if occur borrow, then $C=0$, else $C=1$	√	√	√	1
	MUL A,M	$R, A \leftarrow A * M$, The LB of product stored in Acc and HB stored in R register. ZF affected by Acc.	-	-	√	2
LOGIC	AND A,M	$A \leftarrow A$ and M	-	-	√	1
	AND M,A	$M \leftarrow A$ and M	-	-	√	1+N
	AND A,I	$A \leftarrow A$ and I	-	-	√	1
	OR A,M	$A \leftarrow A$ or M	-	-	√	1
	OR M,A	$M \leftarrow A$ or M	-	-	√	1+N
	OR A,I	$A \leftarrow A$ or I	-	-	√	1
	XOR A,M	$A \leftarrow A$ xor M	-	-	√	1
	XOR M,A	$M \leftarrow A$ xor M	-	-	√	1+N
	XOR A,I	$A \leftarrow A$ xor I	-	-	√	1
PUSH	SWAP M	$A(b3-b0, b7-b4) \leftarrow M(b7-b4, b3-b0)$	-	-	-	1
	SWAPM M	$M(b3-b0, b7-b4) \leftarrow M(b7-b4, b3-b0)$	-	-	-	1+N
	RRC M	$A \leftarrow RRC M$	√	-	-	1
	RRCM M	$M \leftarrow RRC M$	√	-	-	1+N
	RLC M	$A \leftarrow RLC M$	√	-	-	1
	RLCM M	$M \leftarrow RLC M$	√	-	-	1+N
	CLR M	$M \leftarrow 0$	-	-	-	1
	BCLR M.b	$M.b \leftarrow 0$	-	-	-	1+N
	BSET M.b	$M.b \leftarrow 1$	-	-	-	1+N
	B0BCLR M.b	$M(bank\ 0).b \leftarrow 0$	-	-	-	1+N
B0BSET M.b	$M(bank\ 0).b \leftarrow 1$	-	-	-	1+N	
BRANCH	CMPRS A,I	ZF,C $\leftarrow A - I$, If $A = I$, then skip next instruction	√	-	√	1 + S
	CMPRS A,M	ZF,C $\leftarrow A - M$, If $A = M$, then skip next instruction	√	-	√	1 + S
	INCS M	$A \leftarrow M + 1$, If $A = 0$, then skip next instruction	-	-	-	1 + S
	INCMS M	$M \leftarrow M + 1$, If $M = 0$, then skip next instruction	-	-	-	1+N+S
	DECS M	$A \leftarrow M - 1$, If $A = 0$, then skip next instruction	-	-	-	1 + S
	DECMS M	$M \leftarrow M - 1$, If $M = 0$, then skip next instruction	-	-	-	1+N+S
	BTS0 M.b	If $M.b = 0$, then skip next instruction	-	-	-	1 + S
	BTS1 M.b	If $M.b = 1$, then skip next instruction	-	-	-	1 + S
	B0BTS0 M.b	If $M(bank\ 0).b = 0$, then skip next instruction	-	-	-	1 + S
	B0BTS1 M.b	If $M(bank\ 0).b = 1$, then skip next instruction	-	-	-	1 + S
	JMP d	$PC15/14 \leftarrow RomPages1/0, PC13-PC0 \leftarrow d$	-	-	-	2
	CALL d	$Stack \leftarrow PC15-PC0, PC15/14 \leftarrow RomPages1/0, PC13-PC0 \leftarrow d$	-	-	-	2
RET	$PC \leftarrow Stack$	-	-	-	2	
RETI	$PC \leftarrow Stack$, and to enable global interrupt	-	-	-	2	
NOP	No operation	-	-	-	1	

Note: 1. "M" is system register or RAM. If "M" is system registers then "N" = 0, otherwise "N" = 1.
2. If branch condition is true then "S = 1", otherwise "S = 0".

11 ELECTRICAL CHARACTERISTIC

11.1 ABSOLUTE MAXIMUM RATING

Supply voltage (Vdd).....	- 0.3V ~ 6.0V
Input in voltage (Vin).....	Vss – 0.2V ~ Vdd + 0.2V
Operating ambient temperature (Topr)	
SN8P2723P, SN8P2723S, SN8P2723X, SN8P2723T, SN8P27231P, SN8P27231S, SN8P27232P, SN8P27232S	0°C ~ + 70°C
Storage ambient temperature (Tstor)	–40°C ~ + 125°C

11.2 ELECTRICAL CHARACTERISTIC

● DC CHARACTERISTIC

(All of voltages refer to Vss, Vdd = 5.0V, Fosc = 4MHz, Fcpu=1MHz, ambient temperature is 25°C unless otherwise note.)

PARAMETER	SYM.	DESCRIPTION	MIN.	TYP.	MAX.	UNIT	
Operating voltage	Vdd	Normal mode, Vpp = Vdd, 25°C, Fcpu = 1MHz	2.2	-	5.5	V	
		Normal mode, Vpp = Vdd, 0°C~70°C	2.3	-	5.5	V	
RAM Data Retention voltage	Vdr		1.5	-	-	V	
*Vdd rise rate	Vpor	Vdd rise rate to ensure internal power-on reset	0.05	-	-	V/ms	
Input Low Voltage	ViL	All input ports	Vss	-	0.3Vdd	V	
Input High Voltage	ViH	All input ports	0.7Vdd	-	Vdd	V	
Reset pin leakage current	Ilekg	Vin = Vdd	-	-	2	uA	
I/O port input leakage current	Ilekg	Pull-up resistor disable, Vin = Vdd	-	-	2	uA	
I/O port pull-up resistor I/O port pull-down resistor	Rup	Vin = Vss , Vdd = 3V	100	200	300	KΩ	
		Vin = Vss , Vdd = 5V	50	100	150		
I/O output source current sink current	IoH	Vop = Vdd – 0.5V	15	20	-	mA	
	IoL	Vop = Vss + 0.5V	15	20	-		
1/2*Bias Voltage	Vbias	P1.3~P1.6 pull-up/pull-down resistors enable.	2.2	2.5	2.8	V	
*INTn trigger pulse width	Tint0	INT0 interrupt request pulse width	2/fcpu	-	-	cycle	
Supply Current	Idd1	Run Mode (Low power disable)	Vdd= 3V, Fcpu = 16MHz	-	4	-	mA
			Vdd= 5V, Fcpu = 16MHz	-	8	-	mA
			Vdd= 3V, Fcpu = 4MHz	-	2	-	mA
			Vdd= 5V, Fcpu = 4MHz	-	4.5	-	mA
			Vdd= 3V, Fcpu = 1MHz	-	1.6	-	mA
			Vdd= 5V, Fcpu = 1MHz	-	3.9	-	mA
			Vdd= 3V, Fcpu = 32KHz	-	19	-	uA
			Vdd= 5V, Fcpu = 32KHz	-	45	-	uA
	Idd2	Run Mode (Low power enable)	Vdd= 3V, Fcpu = 1MHz	-	1.2	-	mA
			Vdd= 5V, Fcpu = 1MHz	-	2.6	-	mA
	Idd3	Slow Mode (Internal low RC, Stop high clock)	Vdd= 3V, ILRC=16KHz	-	4	-	uA
			Vdd= 5V, ILRC=32KHz	-	12	-	uA
	Idd4	Sleep Mode	Vdd= 5V/3V	-	1	2	uA
	Idd5	Green Mode (No loading, Watchdog Disable)	Vdd= 3V, IHRC=16MHz	-	0.45	-	mA
			Vdd= 5V, IHRC=16MHz	-	0.6	-	mA
			Vdd= 3V, Crystal=16MHz	-	0.45	-	mA
			Vdd= 5V, Crystal=16MHz	-	1.2	-	mA
			Vdd= 3V, Crystal=4MHz	-	0.15	-	mA
Vdd= 5V, Crystal=4MHz			-	0.4	-	mA	
Vdd= 3V, Ext. 32KHz X'tal			-	5	-	uA	
Vdd= 5V, Ext. 32KHz X'tal			-	19.5	-	uA	
Vdd= 3V, ILRC=16KHz			-	2	-	uA	
Vdd= 5V, ILRC=32KHz			-	5	-	uA	
Internal High Oscillator Freq.	Fihrc	25°C, Vdd=2.2V~ 5.5V Fcpu=Fosc/1~Fosc/128	15.68	16	16.32	MHz	
		0°C~70°C, Vdd=2.2V~ 5.5V Fcpu=Fosc/1~Fosc/128	15.2	16	16.8	MHz	
LVD Voltage (Sleep mode)	LVD20	25°C. Trimmed. (Sleep mode)	2.0	2.1	2.2	V	
		0°C~+70°C. Trimmed. (Sleep mode)	1.9	2.1	2.3		
	LVD24	25°C. Trimmed. (Sleep mode)	2.3	2.4	2.5		
		0°C~+70°C. Trimmed. (Sleep mode)	2.2	2.4	2.6		
LVD36	25°C. Trimmed. (Sleep mode)	3.5	3.6	3.7			

		0°C ~ +70°C. Trimmed. (Sleep mode)	3.4	3.6	3.8	
--	--	------------------------------------	-----	-----	-----	--

“*” These parameters are for design reference, not tested.

● **ADC CHARACTERISTIC**

(All of voltages refer to Vss, Vdd = 5.0V, Fosc = 4MHz, Fcpu=1MHz, ambient temperature is 25°C unless otherwise note.)

PARAMETER	SYM.	DESCRIPTION	MIN.	TYP.	MAX.	UNIT
AIN0 ~ AIN11 input voltage	Vani	Vdd = 5.0V	0	-	Avrefh	V
ADC reference Voltage	Verf	External reference voltage, Vdd = 5V.	2.2	-	Vdd	V
	Virf1	Internal VDD reference voltage, Vdd = 5V.		Vdd		V
	Virf2	Internal 3.5V reference voltage, Vdd = 5V, 25°C	3.46	3.5	3.54	V
		Internal 3.5V reference voltage, Vdd = 5V, 0°C~70°C	3.43	3.5	3.57	V
	Virf3	Internal 2.5V reference voltage, Vdd = 5V, 25°C	2.47	2.5	2.53	V
Internal 2.5V reference voltage, Vdd = 5V, 0°C~70°C		2.45	2.5	2.55	V	
*ADC enable time	Tast	Ready to start convert after set ADENB = “1”	100	-	-	us
*ADC current consumption	I _{ADC}	Vdd =5.0V	-	0.3	-	mA
		Vdd =3.0V	-	0.25	-	mA
ADC Clock Frequency	F _{ADCLK}	Vdd =5.0V	-	-	8M	Hz
		Vdd =3.0V	-	-	5M	Hz
ADC Conversion Cycle Time	F _{ADCYL}	Vdd =2.4V~5.5V	64	-	-	1/F _{ADCLK}
ADC Sampling Rate (Set FADS=1 Frequency)	F _{ADSMP}	Vdd =5.0V	-	-	125	K/sec
		Vdd =3.0V	-	-	80	K/sec
Differential Nonlinearity	DNL	Vdd =5.0V , AVREFH=3.2V, F _{ADSMP} =7.8K	-	±4	-	LSB
		Vdd =5.0V , AVREFH=3.2V, F _{ADSMP} =250K	-	±10	-	LSB
Integral Nonlinearity	INL	Vdd =5.0V , AVREFH=3.2V, F _{ADSMP} =7.8K	-	±4	-	LSB
		Vdd =5.0V , AVREFH=3.2V, F _{ADSMP} =250K	-	±10	-	LSB
No Missing Code	NMC	Vdd =5.0V , AVREFH=3.2V, F _{ADSMP} =7.8K	9	10	11	Bits
		Vdd =5.0V , AVREFH=3.2V, F _{ADSMP} =250K	-	8	-	Bits
ADC offset Voltage	V _{ADCOffset}	Non-trimmed	-10	0	+10	mV
		Trimmed	-2	0	+2	mV

“*” These parameters are for design reference, not tested.

11.3 CHARACTERISTIC GRAPHS

The Graphs in this section are for design guidance, not tested or guaranteed. In some graphs, the data presented are outside specified operating range. This is for information only and devices are guaranteed to operate properly only within the specified range (0°C~+70°C curves are for design reference).

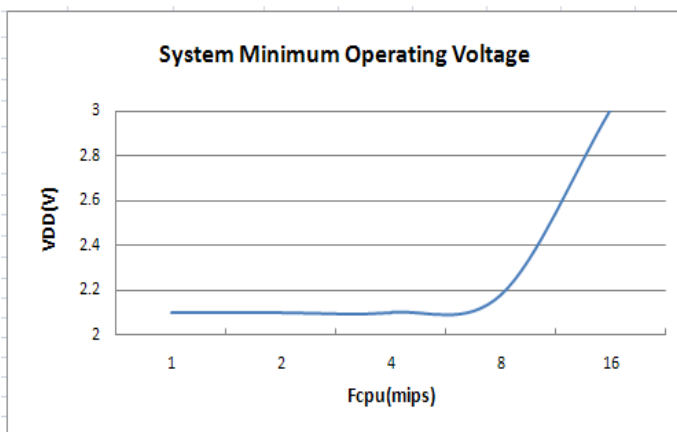
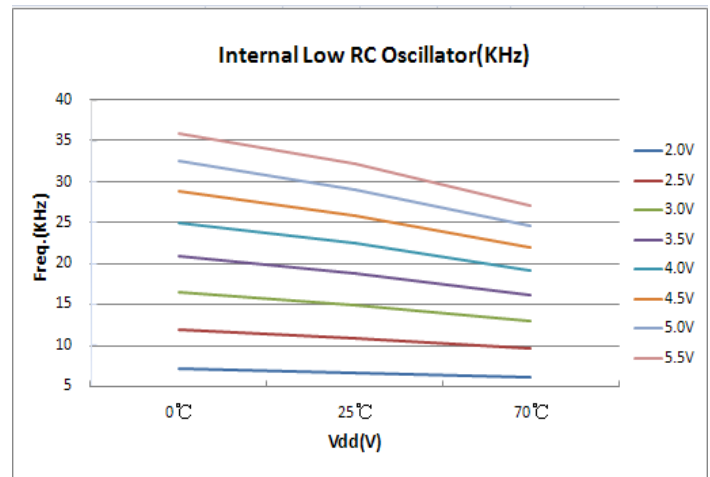
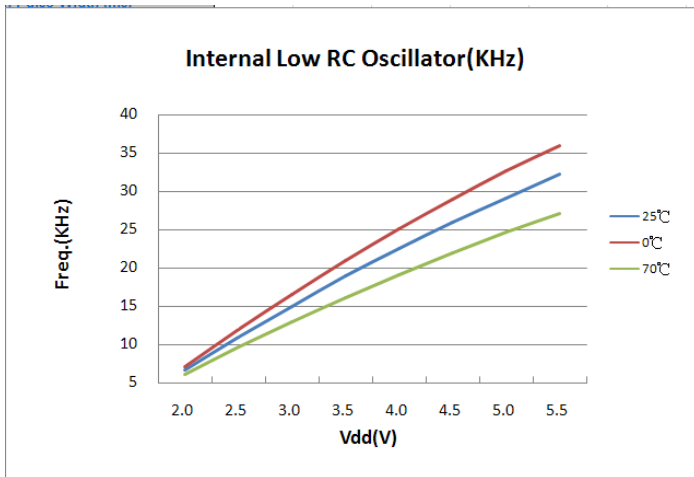
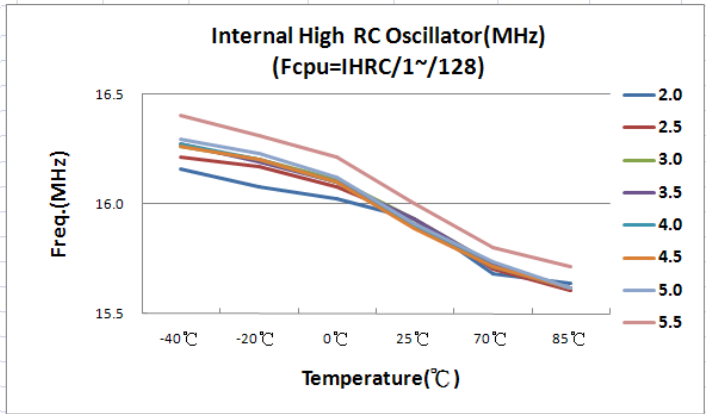
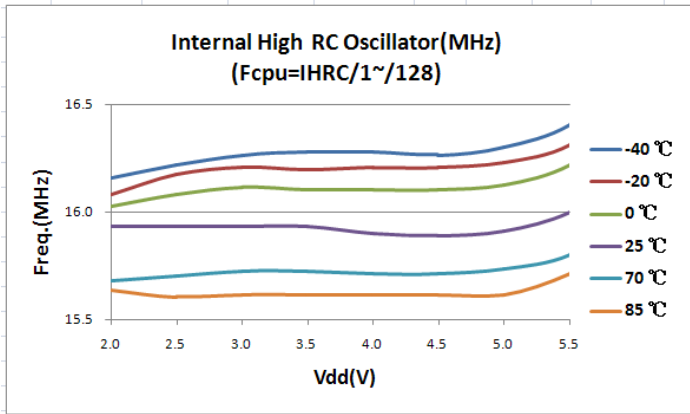

12 DEVELOPMENT TOOL

SONiX provides ICE (in circuit emulation), IDE (Integrated Development Environment) and EV-kit for SN8P2723 development. ICE and EV-kit are external hardware devices, and IDE is a friendly user interface for firmware development and emulation. These development tools' version is as following.

- **ICE: SN8ICE2K Plus II. (Please install 16MHz crystal in ICE to implement for emulation.)**
- **ICE Emulation Speed Maximum: 8 MIPS @ 5V (e.g. 16Mhz crystal, Fcpu = Fosc/2)**
- **EV-KIT: EV2723 KIT REV: V1.0.**
- **IDE: SONiX IDE M2IDE_V139 or greater.**
- **Writer: MPIII writer.**
- **Writer transition board: SN8P2723**

12.1 SN8P2723 EV-KIT

SN8P2723 EV- KIT includes ICE interface, GPIO interface, EV-chip, 6+1 channel PWM module and 3 channel INT module.

EV-chip module: Emulate 12 channel ADC function.

PWM module: Emulate 6+1 channel PWM function.

INT module: Emulate 3 channel INT function.

EV2723 KIT PCB Outline:

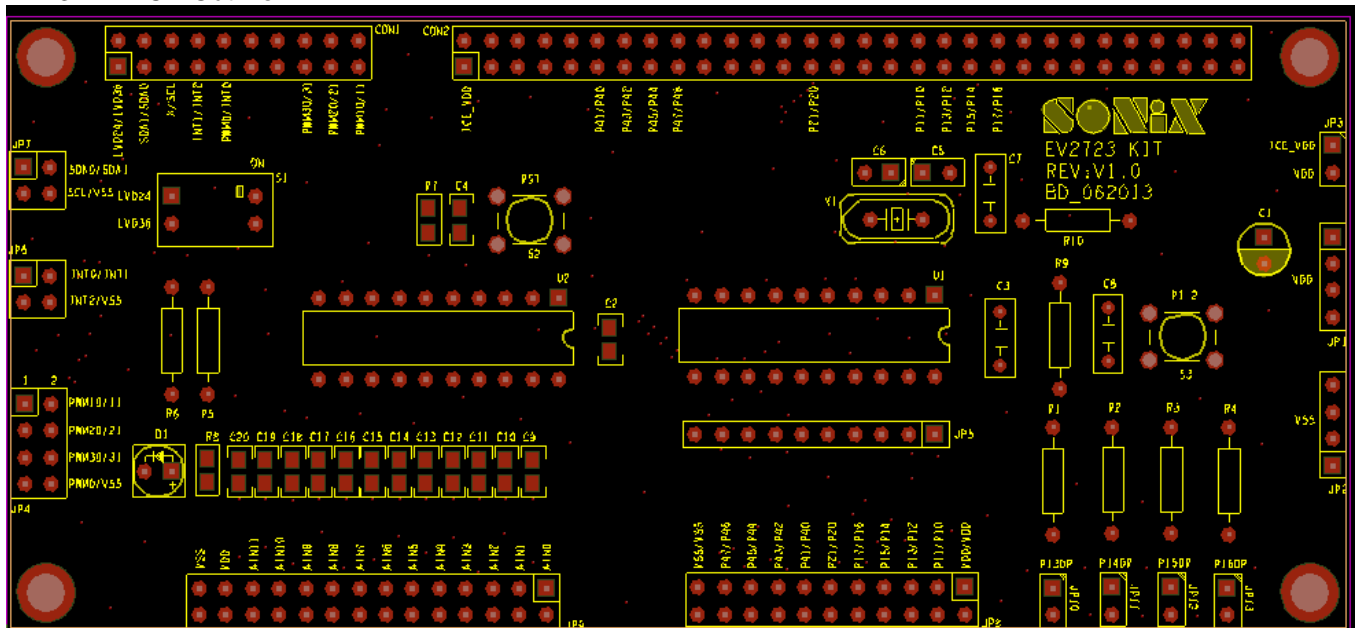

- CON1, CON2: ICE interface connected to SN8ICE2K Plus 2.
- S1: LVD24V / LVD36V control switch. To emulate LVD2.4V flag / reset function and LVD3.6V / flag function.

Switch No.	ON	OFF
LVD24	LVD 2.4V Active	LVD 2.4V Inactive
LVD36	LVD 3.6V Active	LVD 3.6V Inactive

- S2: SN8P2723 EV-chip reset button.
- J1, J2: EV-KIT external power ground connector.
- J3: EV-KIT ICE power connector.
- JP8: GPIO connector.
- JP10~JP13: Short to emulation P1.3~P1.6 internal pull-down resistor.
- U1: SN8P2723 DIP/SOP/SSOP/TSSOP socket for connecting to user's target board.
- U2: SN8P2723 EV-chip for ADC emulation.

- JP4: 6+1 channel PWM connectors.
- JP6: INT0~INT2 connectors.
- JP9 (AIN0~AIN11): 12 channel ADC connectors.
- C9~C20: 12 channel ADC capacitors.

EV2723 KIT schematic:

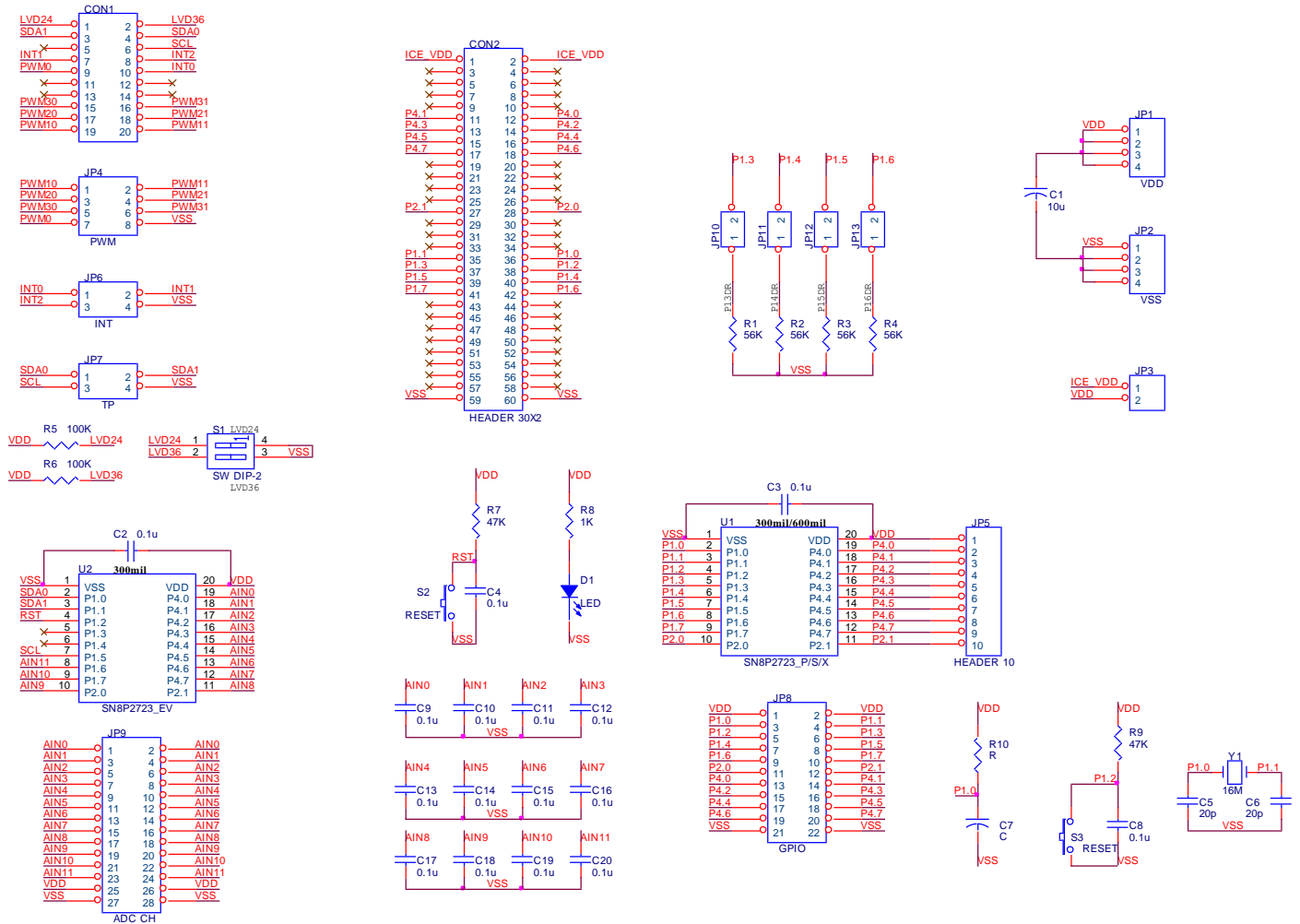

12.2 ICE AND EV-KIT APPLICATION NOTIC

1. SN8ICE2K Plus II power switch must be turned off before connecting EV2723 KIT to SN8ICE2K Plus II.
2. Connect EV-KIT's CON1/CON2 to ICE's JP3/CON1.
3. Turn on SN8ICE2K Plus II power switch to start emulation.
4. It is necessary to use 16MHz crystal in ICE for IHRC_16M mode emulation. SN8ICE2K Plus II doesn't support over 8-mips instruction cycle, but real chip does.
5. SN8ICE2K Plus II doesn't support over 15mA sink/drive current, but real chip can support 20mA sink/drive current.
6. SN8P2723 EV- KIT power switch table as follows:

	JP3	JP1	JP2
ICE Power	SHORT	OPEN	OPEN
External Power	OPEN	SHORT	SHORT

13 OTP PROGRAMMING PIN

13.1 WRITER TRANSITION BOARD SOCKET PIN ASSIGNMENT

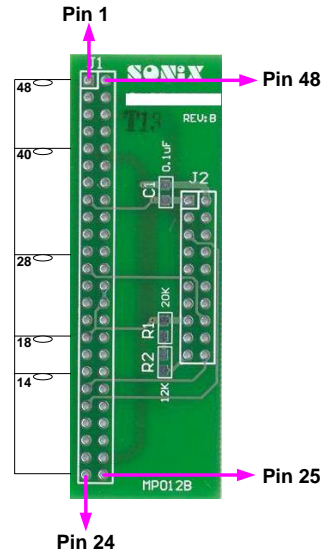

JP3 (Mapping to 48-pin text tool)

DIP 1	1	48	DIP48
DIP 2	2	47	DIP47
DIP 3	3	46	DIP46
DIP 4	4	45	DIP45
DIP 5	5	44	DIP44
DIP 6	6	43	DIP43
DIP 7	7	42	DIP42
DIP 8	8	41	DIP41
DIP 9	9	40	DIP40
DIP10	10	39	DIP39
DIP11	11	38	DIP38
DIP12	12	37	DIP37
DIP13	13	36	DIP36
DIP14	14	35	DIP35
DIP15	15	34	DIP34
DIP16	16	33	DIP33
DIP17	17	32	DIP32
DIP18	18	31	DIP31
DIP19	19	30	DIP30
DIP20	20	29	DIP29
DIP21	21	28	DIP28
DIP22	22	27	DIP27
DIP23	23	26	DIP26
DIP24	24	25	DIP25

Writer JP1/JP2

VDD	1	2	VSS
CLK/PGCLK	3	4	CE
PGM/OTPCLK	5	6	OE/ShiftDat
D1	7	8	D0
D3	9	10	D2
D5	11	12	D4
D7	13	14	D6
VDD	15	16	VPP
HLS	17	18	RST
-	19	20	ALSB/PDB

JP1 for Writer transition board
JP2 for dice and >48 pin package

13.2 PROGRAMMING PIN MAPPING:

Programming Pin Information of SN8P2723 Series							
Chip Name		SN8P2723P/S/X/T(DIP/SOP/SSOP/TSSOP)			SN8P27231P/S(DIP/SOP)		
Writer Connector		IC and JP3 48-pin text tool Pin Assignment					
JP1/JP2 Pin Number	JP1/JP2 Pin Name	IC Pin Number	IC Pin Name	JP3 Pin Number	IC Pin Number	IC Pin Name	JP3 Pin Number
1	VDD	20	VDD		1	VDD	
2	GND	1	VSS		14	VSS	
3	CLK	16	P4.3		11	P4.3	
4	CE	-	-		-	-	
5	PGM	15	P4.4		10	P4.4	
6	OE	14	P4.5		9	P4.5	
7	D1	-	-		-	-	
8	D0	-	-		-	-	
9	D3	-	-		-	-	
10	D2	-	-		-	-	
11	D5	-	-		-	-	
12	D4	-	-		-	-	
13	D7	-	-		-	-	
14	D6	-	-		-	-	
15	VDD	-	-		-	-	
16	VPP	4	RST		4	RST	
17	HLS	-	-		-	-	
18	RST	-	-		-	-	
19	-	-	-		-	-	
20	ALSB/PDB	13	P4.6		8	P4.6	

Programming Pin Information of SN8P2723 Series							
Chip Name		SN8P27232P/S(DIP/SOP)					
Writer Connector		IC and JP3 48-pin text tool Pin Assignment					
JP1/JP2 Pin Number	JP1/JP2 Pin Name	IC Pin Number	IC Pin Name	JP3 Pin Number	IC Pin Number	IC Pin Name	JP3 Pin Number
1	VDD	1	VDD		-	-	
2	GND	16	VSS		-	-	
3	CLK	13	P4.3		-	-	
4	CE	-	-		-	-	
5	PGM	12	P4.4		-	-	
6	OE	11	P4.5		-	-	
7	D1	-	-		-	-	
8	D0	-	-		-	-	
9	D3	-	-		-	-	
10	D2	-	-		-	-	
11	D5	-	-		-	-	
12	D4	-	-		-	-	
13	D7	-	-		-	-	
14	D6	-	-		-	-	
15	VDD	-	-		-	-	
16	VPP	4	RST		-	-	
17	HLS	-	-		-	-	
18	RST	-	-		-	-	
19	-	-	-		-	-	
20	ALSB/PDB	10	P4.6		-	-	

14 Marking Definition

14.1 INTRODUCTION

There are many different types in Sonix 8-bit MCU production line. This note listed the production definition of all 8-bit MCU for order or obtain information. This definition is only for Blank OTP MCU.

14.2 MARKING INDETFICATION SYSTEM

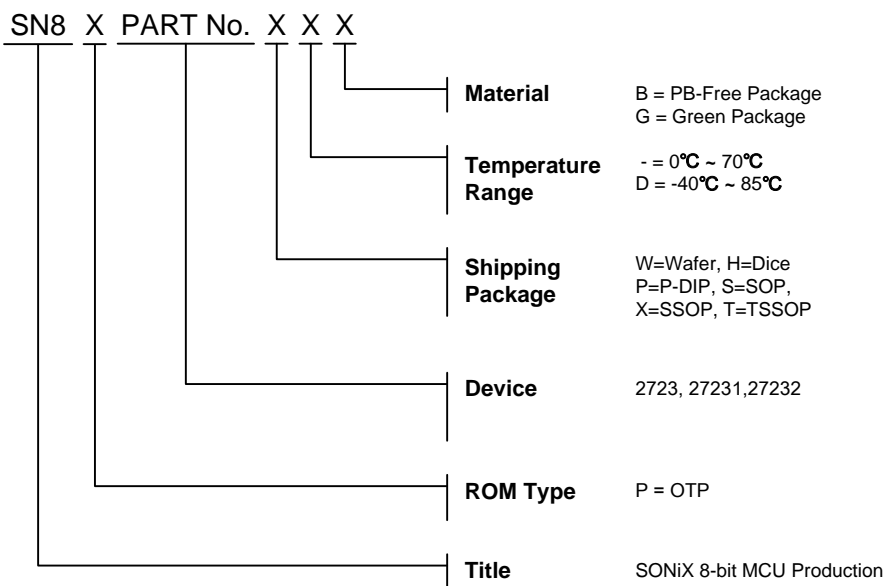

14.3 MARKING EXAMPLE

- **Wafer, Dice:**

Name	ROM Type	Device	Package	Temperature	Material
S8P2723W	OTP	2723	Wafer	0°C ~70°C	-
SN8P2723H	OTP	2723	Dice	0°C ~70°C	-

- **Green Package:**

Name	ROM Type	Device	Package	Temperature	Material
SN8P2723PG	OTP	2723	P-DIP	0°C ~70°C	Green Package
SN8P2723SG	OTP	2723	SOP	0°C ~70°C	Green Package
SN8P2723XG	OTP	2723	SSOP	0°C ~70°C	Green Package
SN8P2723TG	OTP	2723	TSSOP	0°C ~70°C	Green Package
SN8P27231PG	OTP	2723	P-DIP	0°C ~70°C	Green Package
SN8P27231SG	OTP	2723	SOP	0°C ~70°C	Green Package
SN8P27232PG	OTP	2723	P-DIP	0°C ~70°C	Green Package
SN8P27232SG	OTP	2723	SOP	0°C ~70°C	Green Package

● PB-Free Package:

Name	ROM Type	Device	Package	Temperature	Material
SN8P2723PB	OTP	2723	P-DIP	0°C~70°C	PB-Free Package
SN8P2723SB	OTP	2723	SOP	0°C~70°C	PB-Free Package
SN8P2723XB	OTP	2723	SSOP	0°C~70°C	PB-Free Package
SN8P2723TB	OTP	2723	TSSOP	0°C~70°C	PB-Free Package
SN8P27231PB	OTP	2723	P-DIP	0°C~70°C	PB-Free Package
SN8P27231SB	OTP	2723	SOP	0°C~70°C	PB-Free Package
SN8P27232PB	OTP	2723	P-DIP	0°C~70°C	PB-Free Package
SN8P27232SB	OTP	2723	SOP	0°C~70°C	PB-Free Package

14.4 DATECODE SYSTEM

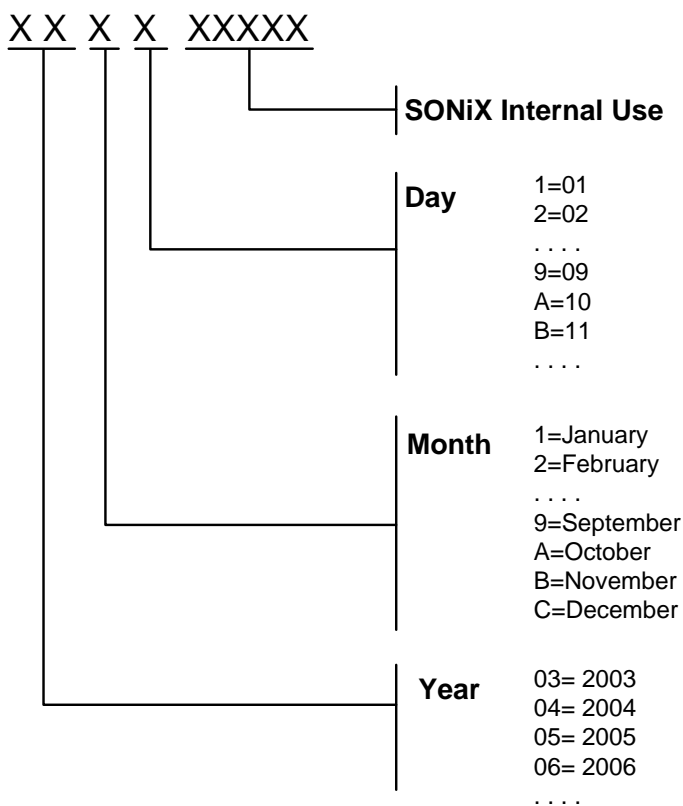

15 PACKAGE INFORMATION

15.1 P-DIP 20 PIN

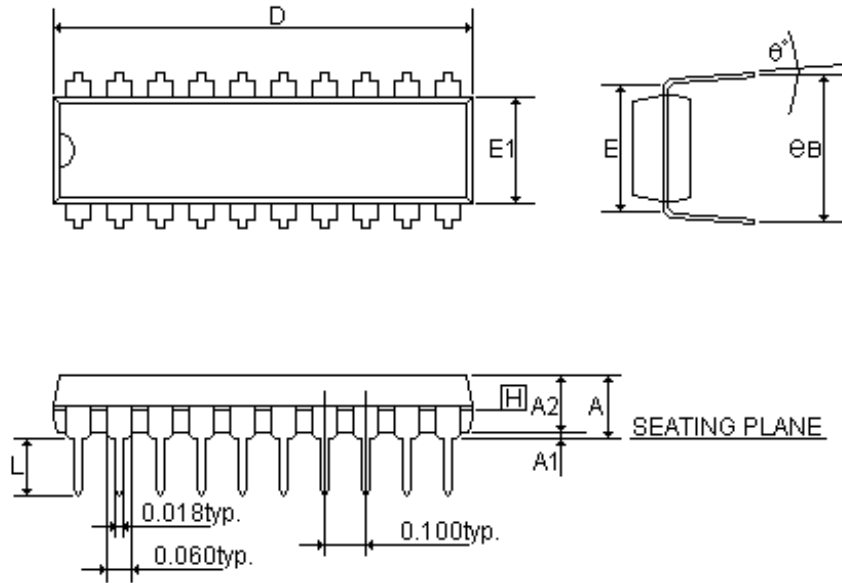

SYMBOLS	MIN	NOR	MAX	MIN	NOR	MAX
	(inch)			(mm)		
A	-	-	0.210	-	-	5.334
A1	0.015	-	-	0.381	-	-
A2	0.125	0.130	0.135	3.175	3.302	3.429
D	0.980	1.030	1.060	24.892	26.162	26.924
E	0.300			7.620		
E1	0.245	0.250	0.255	6.223	6.350	6.477
L	0.115	0.130	0.150	2.921	3.302	3.810
eB	0.335	0.355	0.375	8.509	9.017	9.525
θ°	0°	7°	15°	0°	7°	15°

15.2 SOP 20 PIN

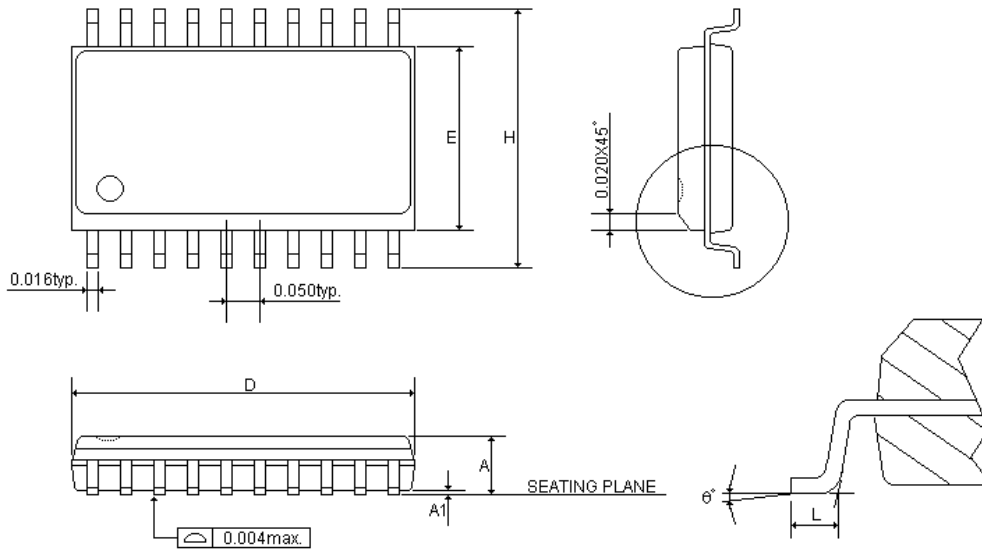

SYMBOLS	MIN	NOR	MAX	MIN	NOR	MAX
	(inch)			(mm)		
A	0.093	0.099	0.104	2.362	2.502	2.642
A1	0.004	0.008	0.012	0.102	0.203	0.305
D	0.496	0.502	0.508	12.598	12.751	12.903
E	0.291	0.295	0.299	7.391	7.493	7.595
H	0.394	0.407	0.419	10.008	10.325	10.643
L	0.016	0.033	0.050	0.406	0.838	1.270
θ°	0°	4°	8°	0°	4°	8°

15.3 SSOP 20 PIN

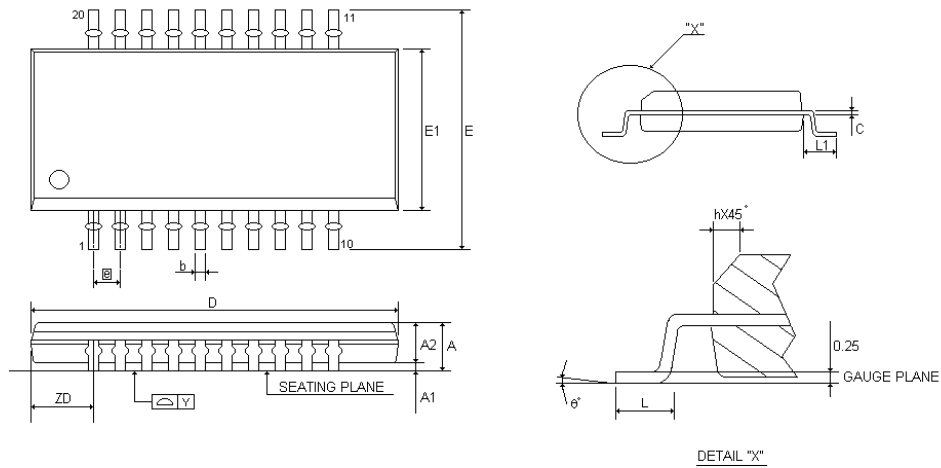

SYMBOLS	MIN	NOR	MAX	MIN	NOR	MAX
	(inch)			(mm)		
A	0.053	0.063	0.069	1.350	1.600	1.750
A1	0.004	0.006	0.010	0.100	0.150	0.250
A2	-	-	0.059	-	-	1.500
b	0.008	0.010	0.012	0.200	0.254	0.300
c	0.007	0.008	0.010	0.180	0.203	0.250
D	0.337	0.341	0.344	8.560	8.660	8.740
E	0.228	0.236	0.244	5.800	6.000	6.200
E1	0.150	0.154	0.157	3.800	3.900	4.000
[e]	0.025			0.635		
h	0.010	0.017	0.020	0.250	0.420	0.500
L	0.016	0.025	0.050	0.400	0.635	1.270
L1	0.039	0.041	0.043	1.000	1.050	1.100
ZD	0.059			1.500		
Y	-	-	0.004	-	-	0.100
θ°	0°	-	8°	0°	-	8°

15.4 TSSOP 20 PIN

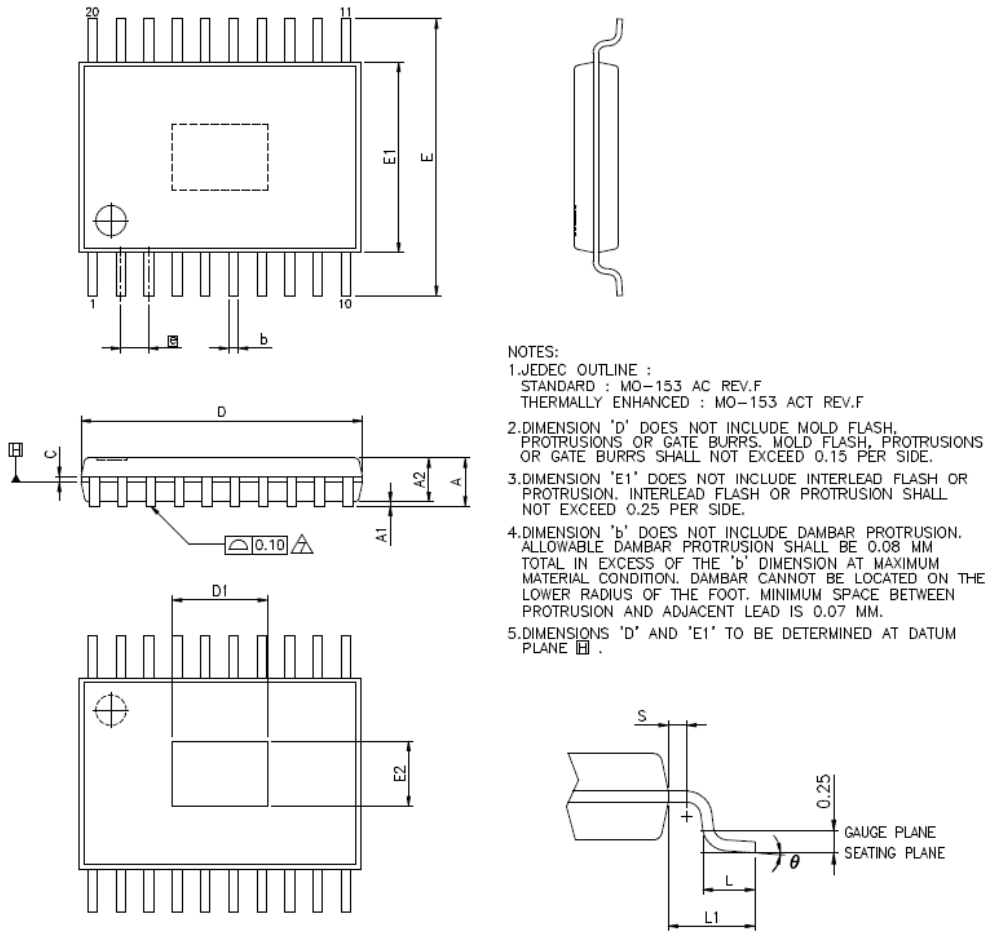

- NOTES:
1. JEDEC OUTLINE :
STANDARD : MO-153 AC REV.F
THERMALLY ENHANCED : MO-153 ACT REV.F
 2. DIMENSION 'D' DOES NOT INCLUDE MOLD FLASH, PROTRUSIONS OR GATE BURRS. MOLD FLASH, PROTRUSIONS OR GATE BURRS SHALL NOT EXCEED 0.15 PER SIDE.
 3. DIMENSION 'E1' DOES NOT INCLUDE INTERLEAD FLASH OR PROTRUSION. INTERLEAD FLASH OR PROTRUSION SHALL NOT EXCEED 0.25 PER SIDE.
 4. DIMENSION 'b' DOES NOT INCLUDE DAMBAR PROTRUSION. ALLOWABLE DAMBAR PROTRUSION SHALL BE 0.08 MM TOTAL IN EXCESS OF THE 'b' DIMENSION AT MAXIMUM MATERIAL CONDITION. DAMBAR CANNOT BE LOCATED ON THE LOWER RADIUS OF THE FOOT. MINIMUM SPACE BETWEEN PROTRUSION AND ADJACENT LEAD IS 0.07 MM.
 5. DIMENSIONS 'D' AND 'E1' TO BE DETERMINED AT DATUM PLANE \square .

SYMBOLS	MIN	NOR	MAX	MIN	NOR	MAX
	(inch)			(mm)		
A	-	-	0.047	-	-	1.2
A1	0.002	-	0.006	0.05	-	0.15
A2	0.031	0.035	0.041	0.80	0.90	1.05
b	0.007	-	0.012	0.19	-	0.30
C	0.004	-	0.008	0.09	-	0.20
D	0.252	0.256	0.260	6.40	6.50	6.60
E	0.252 BSC			6.40 BSC		
E1	0.169	0.173	0.177	4.30	4.40	4.50
[e]	0.026 BSC			0.65 BSC		
L	0.020	0.024	0.030	0.50	0.60	0.75
L1	0.039 REF			1.00 REF		
S	0.008	-	-	0.2	-	-
θ°	0°	-	8°	0°	-	8°

PAD SIZE	E2			D1		
	MIN	NOR	MAX	MIN	NOR	MAX
118X16E	2.60	2.80	3.00	3.79	3.99	4.19

15.5 P-DIP 16 PIN

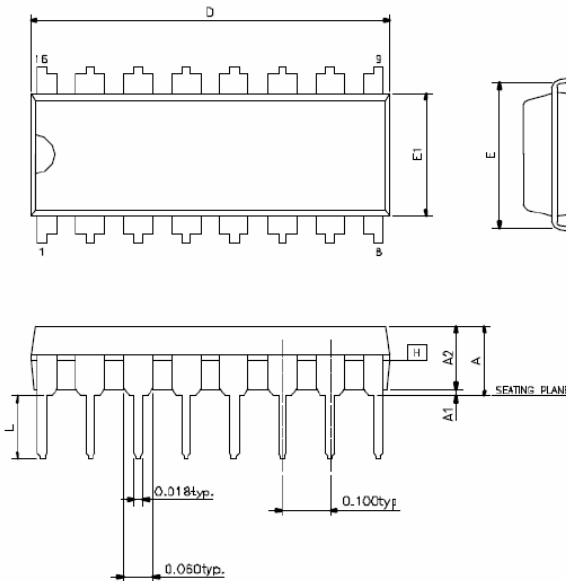

- NOTES:
1. JEDEC OUTLINE : MS-001 BB
 2. "D", "E1" DIMENSIONS DO NOT INCLUDE MOLD FLASH OR PROTRUSIONS. MOLD FLASH OR PROTRUSIONS SHALL NOT EXCEED .010 INCH.
 3. eB IS MEASURED AT THE LEAD TIPS WITH THE LEADS UNCONSTRAINED.
 4. POINTED OR ROUNDED LEAD TIPS ARE PREFERRED TO EASE INSERTION.
 5. DISTANCE BETWEEN LEADS INCLUDING DAM BAR PROTRUSIONS TO BE .005 INCH MINIMUM.
 6. DATUM PLANE \square COINCIDENT WITH THE BOTTOM OF LEAD, WHERE LEAD EXITS BODY.

SYMBOLS	MIN	NOR	MAX	MIN	NOR	MAX
	(inch)			(mm)		
A	-	-	0.210	-	-	5.334
A1	0.015	-	-	0.381	-	-
A2	0.125	0.130	0.135	3.175	3.302	3.429
D	0.735	0.775	0.775	18.669	19.177	19.685
E	0.300BSC			7.620BSC		
E1	0.245	0.250	0.255	6.223	6.350	6.477
L	0.115	0.130	0.150	2.921	3.302	3.810
eB	0.335	0.355	0.375	8.509	9.017	9.525
θ°	0°	7°	15°	0°	7°	15°

15.6 SOP 16 PIN

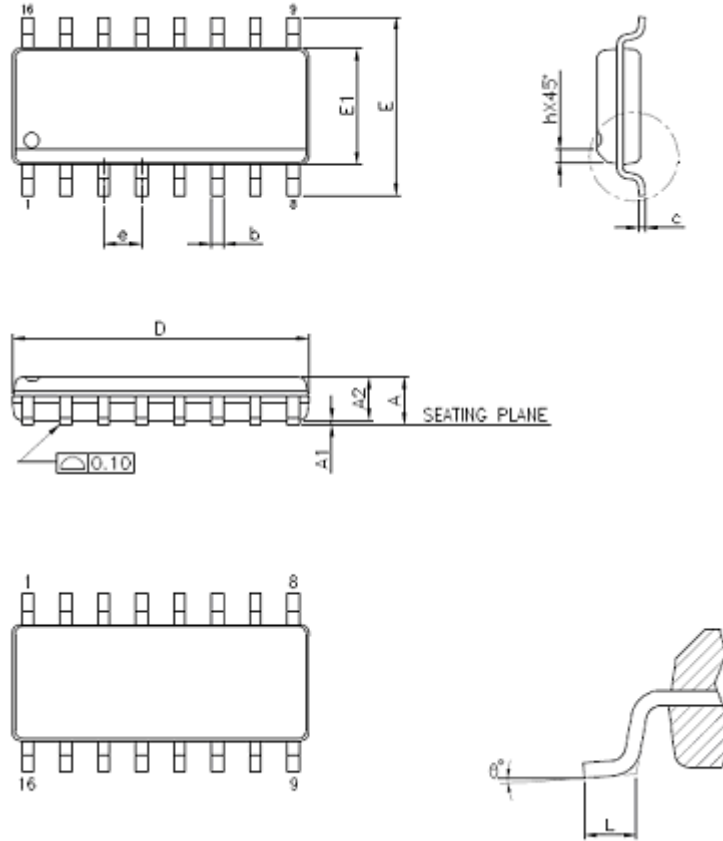

SYMBOLS	MIN	NOR	MAX	MIN	NOR	MAX
	(inch)			(mm)		
A	-	-	0.069	-	-	1.75
A1	0.004	-	0.010	0.10	-	0.25
A2	0.049	-		1.25	-	-
b	0.012	-	0.020	0.31	-	0.51
c	0.004	-	0.010	0.10	-	0.25
D	0.39BSC			9.90BSC		
E	0.236BSC			6.00BSC		
E1	0.154BSC			3.90BSC		
e	0.05BSC			1.27BSC		
h	0.016	-	0.050	0.40	-	1.27
L	0.010	-	0.020	0.25	-	0.50
θ°	0°	-	8°	0°	-	8°

15.7 P-DIP 14 PIN

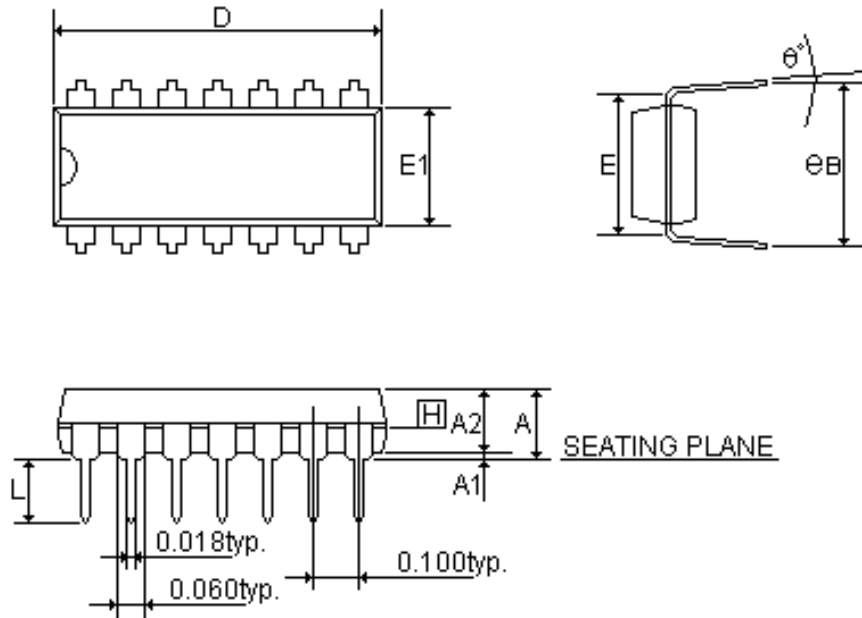

SYMBOLS	MIN	NOR	MAX	MIN	NOR	MAX
	(inch)			(mm)		
A	-	-	0.210	-	-	5.334
A1	0.015	-	-	0.381	-	-
A2	0.125	0.130	0.135	3.175	3.302	3.429
D	0.735	0.075	0.775	18.669	1.905	19.685
E	0.300			7.62		
E1	0.245	0.250	0.255	6.223	6.35	6.477
L	0.115	0.130	0.150	2.921	3.302	3.810
eB	0.335	0.355	0.375	8.509	9.017	9.525
θ°	0°	7°	15°	0°	7°	15°

15.8 SOP 14 PIN

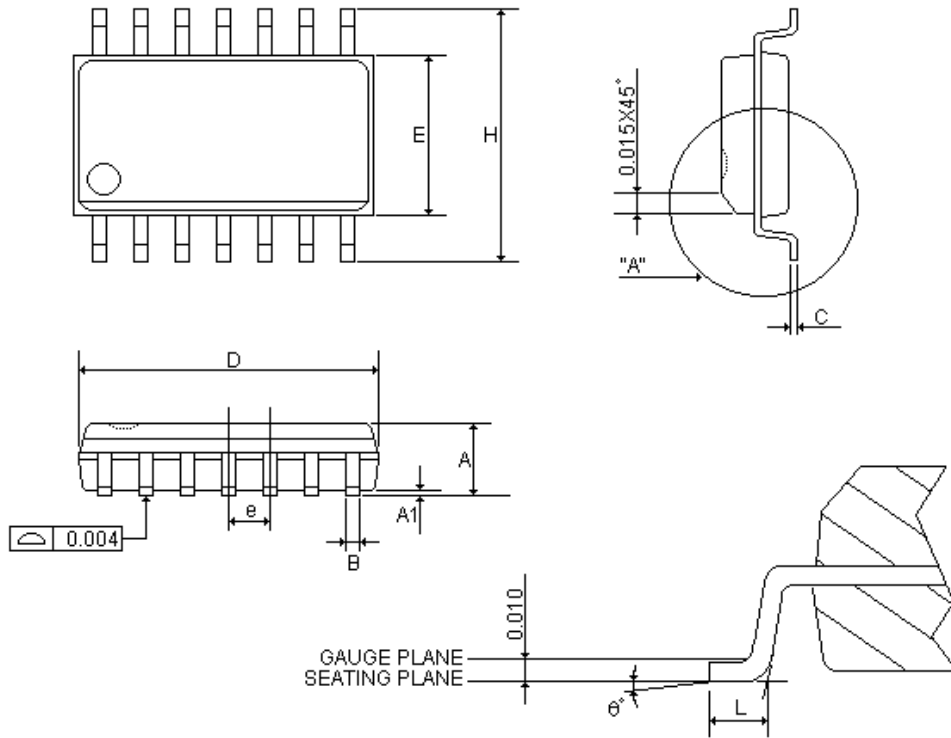

SYMBOLS	MIN	NOR	MAX	MIN	NOR	MAX
	(inch)			(mm)		
A	0.058	0.064	0.068	1.4732	1.6256	1.7272
A1	0.004	-	0.010	0.1016	-	0.254
B	0.013	0.016	0.020	0.3302	0.4064	0.508
C	0.0075	0.008	0.0098	0.1905	0.2032	0.2490
D	0.336	0.341	0.344	8.5344	8.6614	8.7376
E	0.150	0.154	0.157	3.81	3.9116	3.9878
e	-	0.050	-	-	1.27	-
H	0.228	0.236	0.244	5.7912	5.9944	6.1976
L	0.015	0.025	0.050	0.381	0.635	1.27
θ°	0°	-	8°	0°	-	8°

SONiX reserves the right to make change without further notice to any products herein to improve reliability, function or design. SONiX does not assume any liability arising out of the application or use of any product or circuit described herein; neither does it convey any license under its patent rights nor the rights of others. SONiX products are not designed, intended, or authorized for use as components in systems intended, for surgical implant into the body, or other applications intended to support or sustain life, or for any other application in which the failure of the SONiX product could create a situation where personal injury or death may occur. Should Buyer purchase or use SONiX products for any such unintended or unauthorized application. Buyer shall indemnify and hold SONiX and its officers, employees, subsidiaries, affiliates and distributors harmless against all claims, cost, damages, and expenses, and reasonable attorney fees arising out of, directly or indirectly, any claim of personal injury or death associated with such unintended or unauthorized use even if such claim alleges that SONiX was negligent regarding the design or manufacture of the part.

Corporate Headquarters:

10F-1, No.36, Taiyuan Street, Chupei City, Hsinchu, Taiwan
TEL : (886)3-5600-888 FAX : (886)3-5600-889

Taipei Sales Office:

15F-2, No.171 Song Ted Road, Taipei, Taiwan
TEL: (886)2-2759-1980 FAX: (886)2-2759-8180
mkt@sonix.com.tw | sales@sonix.com.tw

Hong Kong Sales Office:

Unit 2603, 26/F CCT Telecom Building, No. 11 Wo Shing Street,
Fo Tan, New Territories, Hong Kong
TEL: (852)2723-8086 FAX: (852)2723-9179
hk@sonix.com.tw

Shenzhen Contact Office:

High Tech Industrial Park, Shenzhen, China
TEL: (86)755-2671-9666 FAX: (86)755-2671-9786
mkt@sonix.com.tw | sales@sonix.com.tw

Sonix Japan Office:

Kobayashi bldg. 2F, 4-8-27, Kudanminami, Chiyodaku, Tokyo,
102-0074, Japan
TEL: (81)3-6272-6070 FAX: (81)3-6272-6165
jpsales@sonix.com.tw

FAE Support via Email:

8-bit Microcontroller Products: sa1fae@sonix.com.tw
All Products: fae@sonix.com.tw