



Product Description

Sirenza Microdevices' SNA-200 is a GaAs monolithic broadband amplifier (MMIC) in die form. At 1950 MHz, this amplifier provides 15.5dB and 13.8dB at 6000 MHz.

These unconditionally stable amplifiers are designed for use as general purpose 50 ohm gain blocks. Its small size (0.350m x 0.345mm) and gold metallization make it an ideal choice for use in hybrid circuits. The SNA-200 is 100% DC tested and sample tested for RF performance.

External DC decoupling capacitors determine low frequency response. The use of an external resistor allows for bias flexibility and stability.

The SNA-200 is supplied in gel paks at 100 devices per pak. Also available in packaged form (SNA-276 & SNA-286)

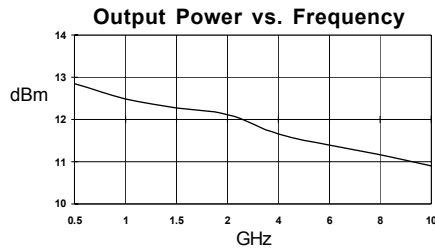

SNA-200S

DC-6.5 GHz, Cascadable GaAs HBT MMIC Amplifier

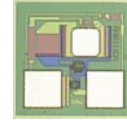

Product Features

- Cascadable 50 Ohm Gain Block
- 15.5dB Gain, +12dBm P1dB
- 1.5:1 Input and Output VSWR
- Operates From Single Supply
- Through wafer via for ground

Applications

- Broadband Driver Amplifier
- IF Amplifier or gain stage for VSAT, LMDS, WLAN, and Cellular Systems

| Symbol | Parameter | Units | Frequency | Min. | Typ. | Max. |
|----------------------|---|-------|-------------|------|---------|------|
| G _p | Small Signal Power Gain [2] | dB | 850 MHz | | 15.5 | |
| | | dB | 1950 MHz | 13.5 | 15.0 | 16.5 |
| | | dB | 2400 MHz | | 15.0 | |
| | | dB | 6000 MHz | 12.3 | 13.8 | 15.3 |
| G _F | Gain Ripple | dB | 0.1-4.0 GHz | | +/- 1.0 | |
| BW3dB | 3dB Bandwidth | GHz | | | 7 | |
| P _{1dB} | Output Power at 1dB Compression [2] | dBm | 1950 MHz | 10 | 12.0 | |
| | | dBm | 6000 MHz | 10.2 | 12.2 | |
| OIP ₃ | Output Third Order Intercept Point [2] | dBm | 1950 MHz | 22 | 25.0 | |
| | | dBm | 6000 MHz | 21.5 | 24.5 | |
| NF | Noise Figure | dB | 1950 MHz | | 5.5 | |
| RL | Input / Output Return Loss | dB | 1950 | | 12.9 | |
| ISOL | Reverse Isolation | dB | 0.1-7.0 GHz | | 20 | |
| V _D | Device Operating Voltage [1] | V | | 3.1 | 3.6 | 4.1 |
| I _D | Device Operating Current [1] | mA | | 35 | 40 | 45 |
| dG/dT | Device Gain Temperature Coefficient | dB/°C | | | -0.0018 | |
| R _{TH, j-b} | Thermal Resistance (junction to backside) | °C/W | | | 270 | |

Test Conditions: V_S = 8 V, I_D = 40 mA Typ., OIP₃ Tone Spacing = 1.2 MHz, Pout per tone = 0 dBm
R_{BIAS} = 110 Ohms, T_L = 25°C, Z_S = Z_L = 50 Ohms, [1] 100% DC Tested, [2] Sample Tested

The information provided herein is believed to be reliable at press time. Sirenza Microdevices assumes no responsibility for inaccuracies or omissions. Sirenza Microdevices assumes no responsibility for the use of this information, and all such information shall be entirely at the user's own risk. Prices and specifications are subject to change without notice. No patent rights or licenses to any of the circuits described herein are implied or granted to any third party. Sirenza Microdevices does not authorize or warrant any Sirenza Microdevices product for use in life-support devices and/or systems. Copyright 2001 Sirenza Microdevices, Inc. All worldwide rights reserved.

303 South Technology Court
Broomfield, CO 80021

Phone: (800) SMI-MMIC

<http://www.sirenza.com>



SNA-200S DC-6.5 GHz Cascadable MMIC Amplifier

Typical Performance at 25° C (V_{ds} = 3.8V, I_{ds} = 40mA)
 (data includes bond wires)

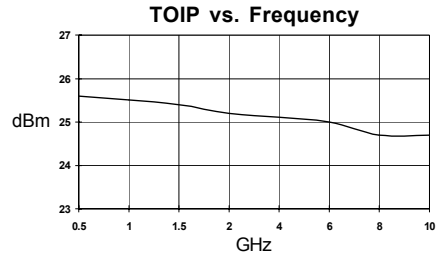
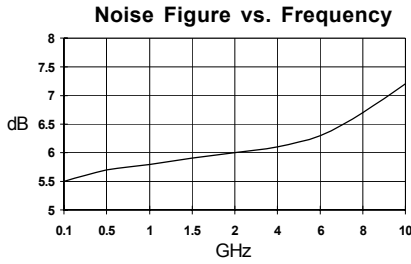
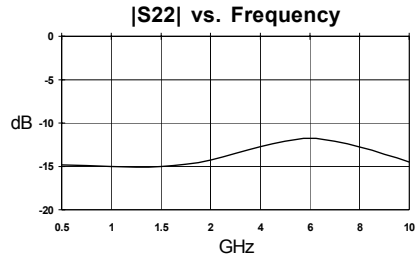
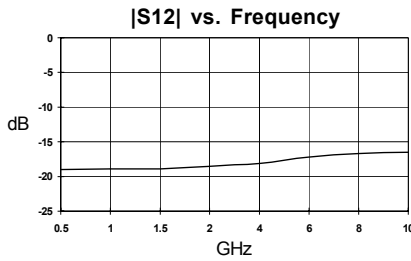
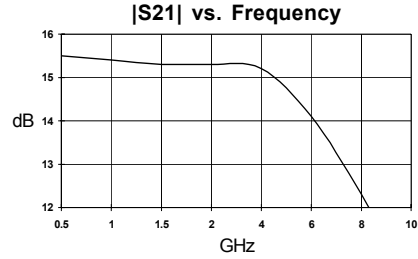
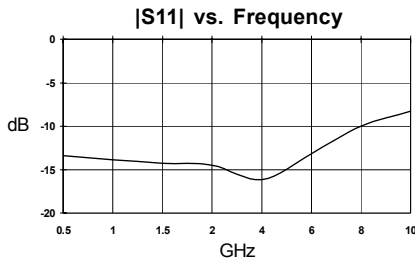

Absolute Maximum Ratings

| Parameter | Absolute Limit |
|---|----------------|
| Max. Device Current (I _D) | 70 mA |
| Max. Device Voltage (V _D) | 6 V |
| Max. RF Input Power | +20 dBm |
| Max. Junction Temp. (T _J) | +200°C |
| Operating Temp. Range (T _L) | -40°C to +85°C |
| Max. Storage Temp. | +150°C |

Operation of this device beyond any one of these limits may cause permanent damage. For reliable continuous operation, the device voltage and current must not exceed the maximum operating values specified in the table on page one.

Bias Conditions should also satisfy the following expression:

$$I_D V_D < (T_J - T_L) / R_{TH} j-I$$



SNA-200S DC-6.5 GHz Cascadable MMIC Amplifier

Application Circuit Element Values

| Reference Designator | Frequency (Mhz) | | | | |
|----------------------|-----------------|--------|-------|-------|-------|
| | 500 | 850 | 1950 | 2400 | 3500 |
| C_B | 220 pF | 100 pF | 68 pF | 56 pF | 39 pF |
| C_D | 100 pF | 68 pF | 22 pF | 22 pF | 15 pF |
| L_C | 68 nH | 33 nH | 22 nH | 18 nH | 15 nH |

Recommended Bias Resistor Values for $I_D = 40\text{mA}$

$$R_{BIAS} = (V_S - V_D) / I_D$$

| Supply Voltage (V_S) | 6V | 8V | 10V | 12V |
|--------------------------|-----|------|------|------|
| R_{BIAS} | 60Ω | 110Ω | 160Ω | 210Ω |

Note: R_{BIAS} provides DC bias stability over temperature.

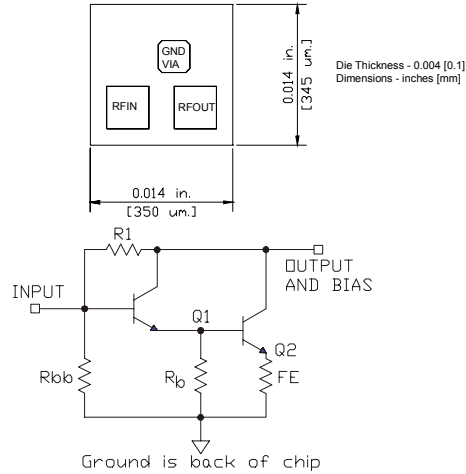
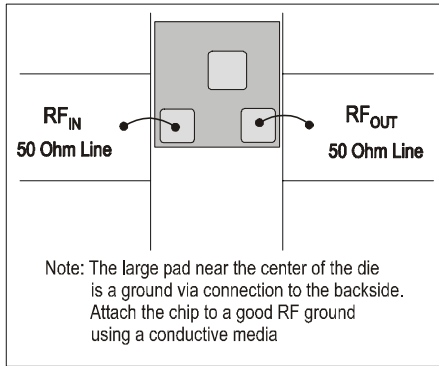
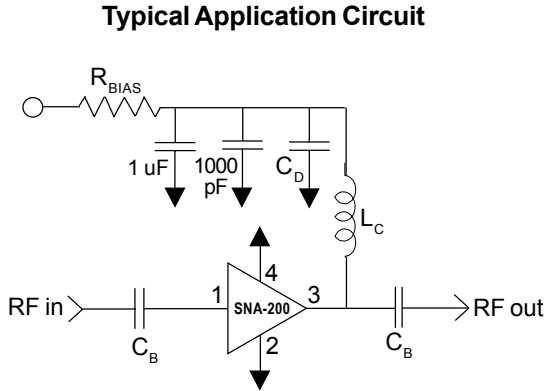

Simplified Schematic of MMIC

For recommended handling, die attach, and bonding methods, see the following application note at www.sirenza.com.

AN-041 (PDF) Handling of Unpackaged Die



Caution: ESD sensitive
Appropriate precautions in handling, packaging and testing devices must be observed.

Part Number Ordering Information

| Part Number | Gel Pack |
|-------------|-------------------|
| SNA-200S | 100 pcs. per pack |

Die are shipped per Sirenza application note AN-039 Visual Criteria For Unpackaged Die