



===== **CONTENTS** =====

<b>1</b>	<b>INTRODUCTION.....</b>	<b>3</b>
<b>2</b>	<b>FEATURES .....</b>	<b>3</b>
<b>3</b>	<b>PIN ASSIGNMENT .....</b>	<b>4</b>
<b>4</b>	<b>BLOCK DIAGRAM .....</b>	<b>5</b>
<b>5</b>	<b>FUNCTION DESCRIPTION.....</b>	<b>5</b>
5.1.	OSCILLATOR.....	5
5.2.	ROM.....	6
5.3.	RAM.....	6
5.4.	POWER DOWN MODE .....	6
5.5.	IR FUNCTION.....	7
5.6.	I/O PORTS .....	7
5.7.	SAMPLING RATE COUNTERS.....	7
5.8.	AUTO REPETITION .....	8
5.9.	VOICE SYNTHESIZER .....	8
5.10.	DAC .....	8
<b>6</b>	<b>APPLICATION CIRCUIT.....</b>	<b>9</b>
<b>7</b>	<b>ABSOLUTE MAXIMUM RATING.....</b>	<b>12</b>
<b>8</b>	<b>ELECTRICAL CHARACTERISTICS.....</b>	<b>12</b>



**AMENDMENT HISTORY**

<b>Version</b>	<b>Date</b>	<b>Description</b>
Ver 1.0	October 07, 2004	First issue
Ver 1.1	November 12, 2004	Modify Application Circuit.
Ver 1.2	March 21, 2005	1. Oscillator R-Type is "no connect". Page5 2. Modify Application Circuit.(Low CLK Mode, 32768, R-Type, Xin and Xout no connect) Page10 3. Modify Electric Characteristic (Max->Typical) Page12 4. Modify I/O Circuit in Page7
Ver1.3	June 30,2005	1. Modify RAM Block in Page6 2. Modify Application circuit in Low CLK(RC mode) R=91K, C=200pF. 3. In Application Circuit add R=100 (direct key) in Page9
Ver1.4	November 18,2005	1. Modify Application circuit add R=100 in each input pin (direct Key).
Ver1.5	September,8,2006	1. Removed Application circuit R=100 in each input pin (direct key)



## 1 INTRODUCTION

The SNC82120 is a single chip 12-channel MIDI compatible wave-table/voice synthesizer. Equipped with a powerful 8-bit controller and 24 I/O pins, it provides a low-cost MIDI sound system solution. It's low power consumption and operating range makes it ideal for all battery operated devices using MIDI or voice synthesis.

## 2 FEATURES

- ◆ Single Power Supply 2.4V – 5.5V
- ◆ Powerful Built-in 8-bit Controller
- ◆ Three 8-bit I/O ports
- ◆ 384\*8 bits RAM
- ◆ Maximum 64k program ROM
- ◆ 384K\*12 shared ROM for program and voice data
- ◆ Readable ROM code data
- ◆ 12-voice Polyphony through a high-quality speech synthesizer
- ◆ Mark Event Supported in both Wave and Melody.
- ◆ Individual adaptive playing speed from 4k-64kHz for all 12 channels
- ◆ Automatic repetition for each channel
- ◆ Volume modulation controlled by embedded multiplier
- ◆ One digital mixers with saturation control
- ◆ One built-in 10-bit current mode DA converters
- ◆ **Analog** Direct Drive speaker circuit.
- ◆ System clock: 16.384M Hz (RC-type or Crystal Option)
- ◆ 2 MIPS CPU power free to user
- ◆ Low Voltage Reset

### 3 PIN ASSIGNMENT

Symbol	I/O	Function Description
P00 ~ P07	I/O	Bit7 ~ Bit0 of I/O port 0
P10 ~ P17	I/O	Bit7 ~ Bit0 of I/O port 1
P20 ~ P27	I/O	Bit7 ~ Bit0 of I/O port 2
VDDVR	P	Positive power supply for ROSC
GNDVR	P	Negative power supply for ROSC
VDDPP	P	Positive power supply for Direct Drive
GNDPP	P	Negative power supply for Direct Drive
CVDD	P	Positive power supply for internal circuit
VDD	P	Positive power supply for I/O
GND	P	Negative power supply
REGOUT	P	3V regulator output
RST	I	Chip Reset (Active low)
XIN	I	High clock Crystal In
XOUT	O	High clock Crystal Out
LXIN	I	Low clock Crystal In
LXOUT	O	Low clock Crystal Out
CKSEL	I	Clock type select 'VDD' → RC oscillator 'GND' →Crystal
TestM	I	Test Pin
VO	O	DA output
BN0	O	Direct Drive negative output
BP0	O	Direct Drive positive output

## 4 Block Diagram

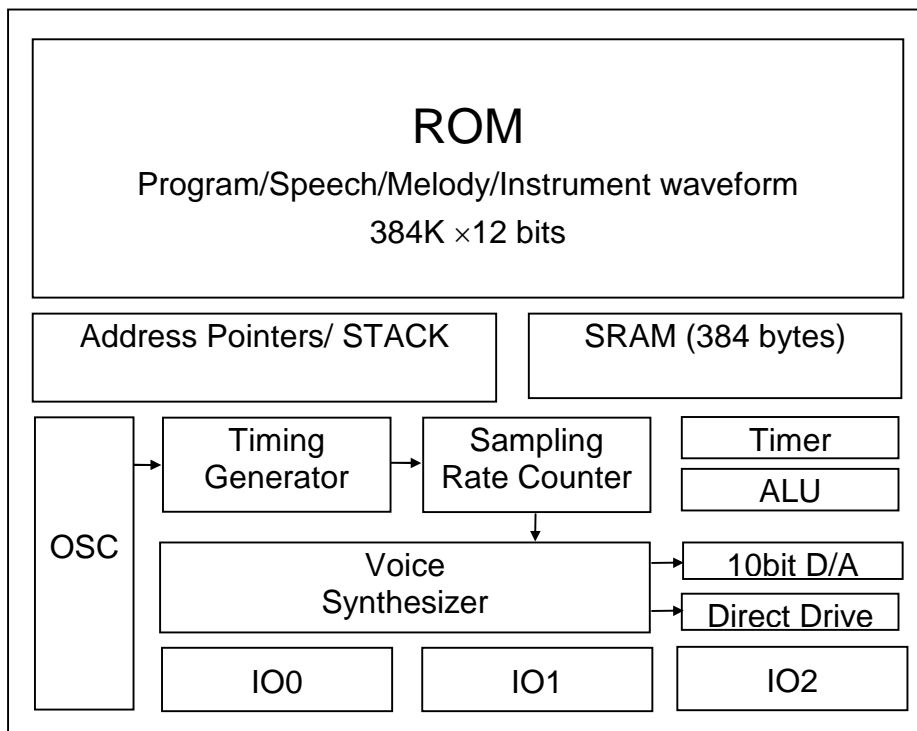

## 5 FUNCTION DESCRIPTION

### 5.1. Oscillator

CKSEL (Clock Select) input pin of the SNC82120 selects between crystal oscillator/ceramic resonator or RC type oscillators as system clock.

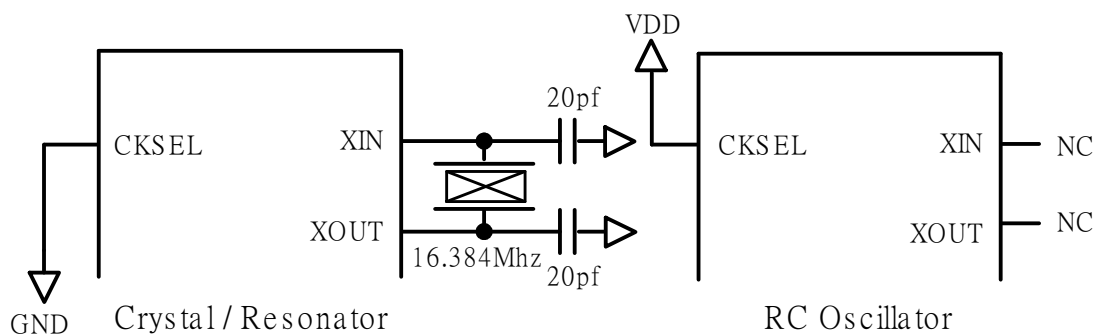

**Notice: For RC Oscillator, Keep XOUT and XIN as “No Connect”.**

### 5.2. ROM

SNC82120 contains a substantial 384K x 12-bit word internal ROM which is shared by program and resource data. Program, voice, melodies, data, and instrument waveforms are shared within this same 384K words ROM.

### 5.3. RAM

SNC82120 contains 384 bytes RAM (384 x 8-bits). The 384 byte RAM is divided into five pages (page0, 1 and 4, 128 bytes RAM for each page). The RAMBK register is used to switch to a specific RAM page. For example, declaring

```
Org      0x250
UseMem  ds  1
```

would locate one byte memory for "UseMem" at BANK 4. Setting 'RAMbk = 4' in a program would switch to bank 4 of RAM.

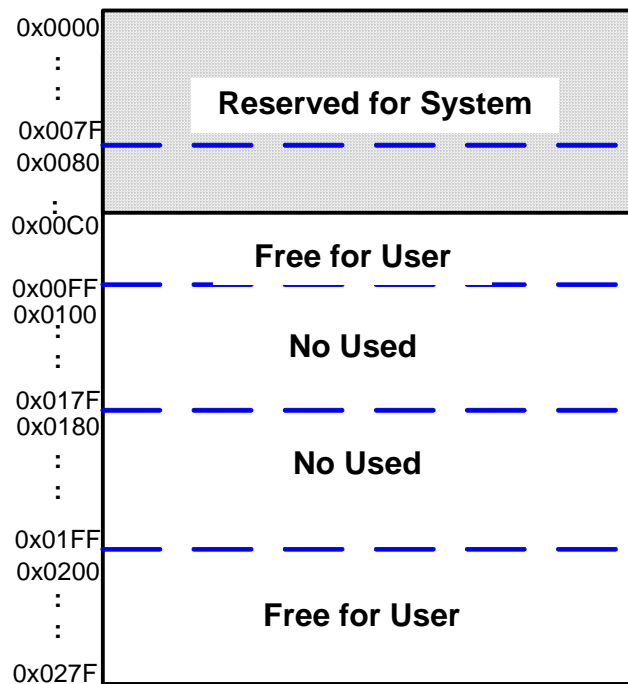

**Notice:** (C0~FFh) and (200~27Fh) Bank4 is free for user.

### 5.4. Power Down Mode

Entering the IC into Stop Mode will stop the system clock for power savings (<3uA @VDD=3V and <6uA @VDD=4.5V). Any transition (L→H or H→L) on any I/O pin or RTC (Real-time clock) can be used to start the system clock and return to normal operating mode.

### 5.5. IR Function

When IR is enabled, a 38.5KHz square wave is gated with P27. The 38.5KHz IR signal is present at the pin when P27 is set to "1".

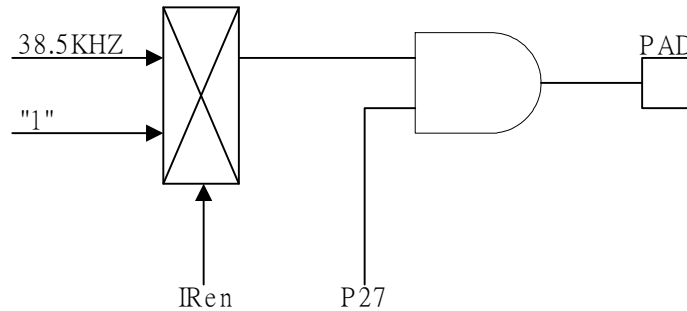

### 5.6. I/O Ports

There are three 8-bit I/O ports P0, P1, and P2. Any I/O can be individually programmed as either input or output. When I/O is set to input, any valid data transition (H→L or L→H) of each I/O port can wake-up the chip from power-down mode.

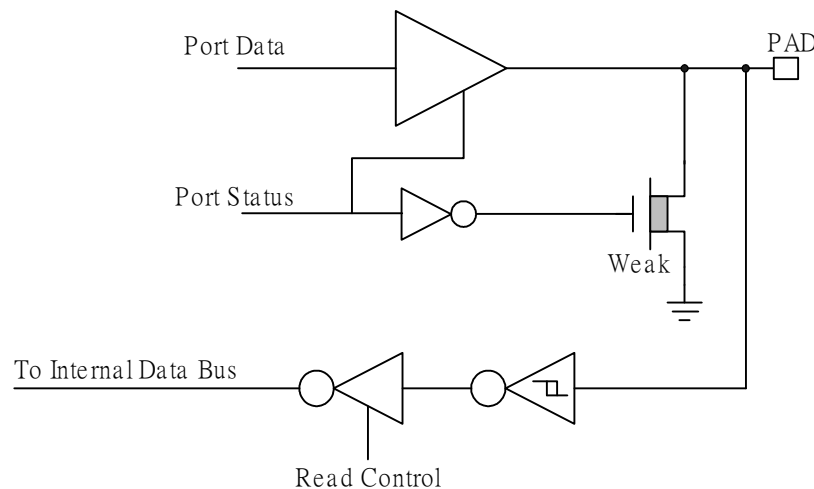

#### I/O Port Configuration

**Note: weak N-MOS's can serve as pull-low resistors.**

### 5.7. Sampling Rate Counters

Each voice channel of 12 is equipped with an independent sampling rate counter to allow individual sample rate play back per channel. Channel sample rate play back can be dynamically set from 4KHz to 64KHz. Each sampling rate counter is updated on a period of 0.125uS. This architecture yields a high-quality music/voice synthesis that sounds very close to its original source when played through the same amplifier and speaker circuitry.

### 5.8. Auto Repetition

Each voice channel of 12 is equipped with a hardware auto repeat function. Auto repeat functions are normally used to implement sustain in instrument synthesis but can even be used to repeat any voice data of arbitrary length.

### 5.9. Voice Synthesizer

The Major function of Voice Synthesizer is to fetch Wave data from ROM and synthesize into voice. Each voice channel of 12 is equipped with an individual volume setting.

### 5.10. DAC

One 10-bit current type digital-to-analog converters are built-in SNC82120. The relationship between input digital data and output analog current signal is listed in the following table.

Input data	Typical value of output current (mA)
0	0
1	3/1023
...	
N	$n \cdot (3/1023)$
...	
1023	3

Recommended application circuits are illustrated below.

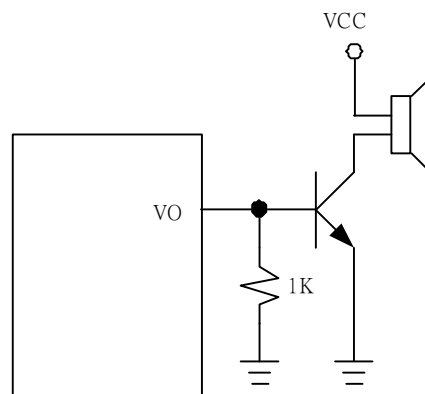

Single Speaker Application



## 6 APPLICATION CIRCUIT

- ◆ Power Supply: 3.0V
- ◆ System Clock: Rosc with calibration or RTC function
- ◆ Low Clock: 32768
- ◆ Voice output: Direct Drive Output

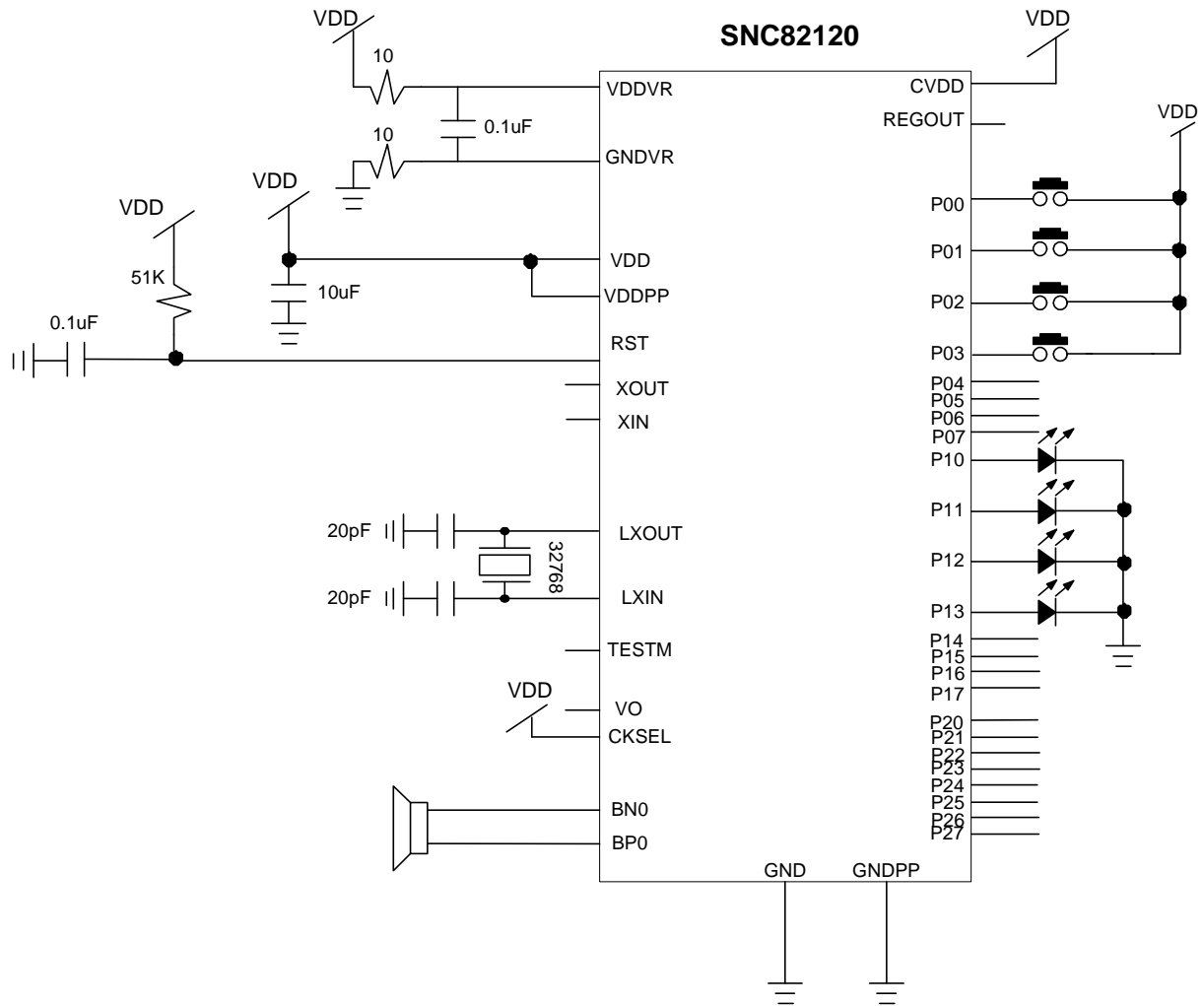

**Notice: If system clock is ROSC, please leave Xout and Xin as "no connect".**

- ◆ Power Supply: 4.5V
- ◆ System Clock: Rosc with calibration or RTC function
- ◆ Low Clock: R-Type
- ◆ Voice output: DA output

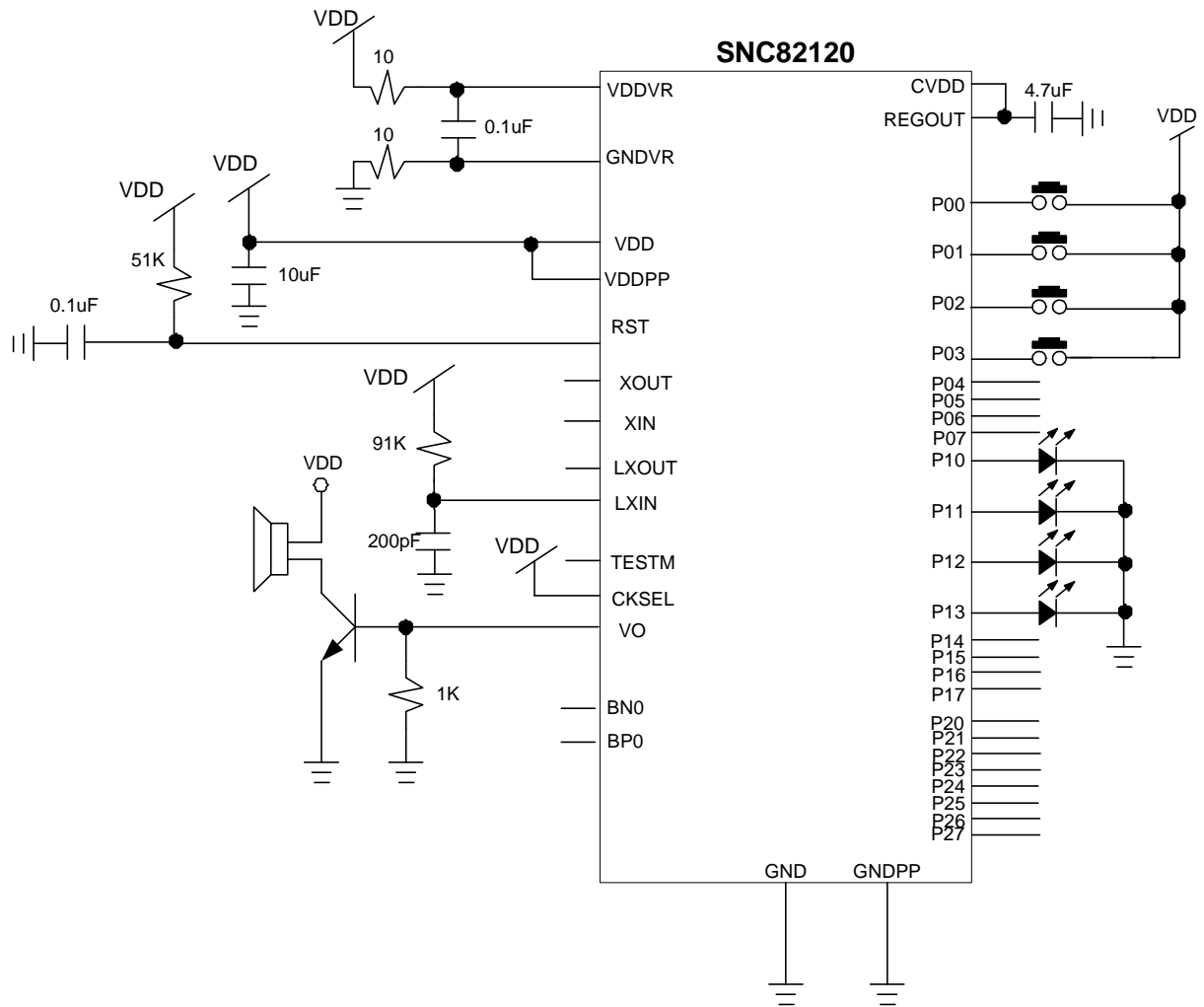

**Notice: If system clock is ROSC, please leave Xout and Xin as "no connect".**

- ◆ Power Supply: 4.5V
- ◆ System Clock: 16.384M Crystal
- ◆ Voice output: DA output

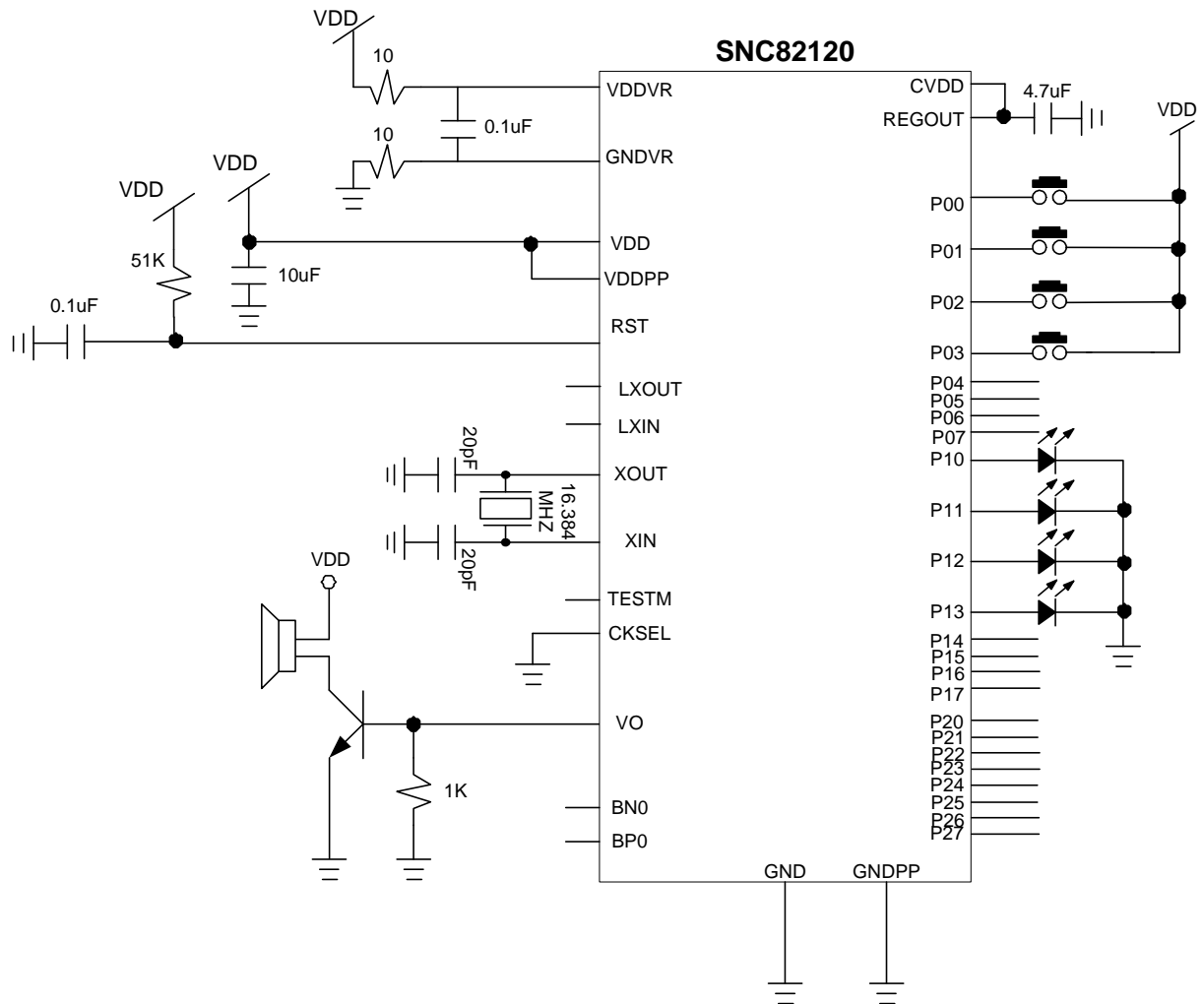

## 7 ABSOLUTE MAXIMUM RATING

Items	Symbol	Min	Max	Unit.
Supply Voltage	$V_{DD-V}$	-0.3	6.0	V
Input Voltage	$V_{IN}$	$V_{SS}-0.3$	$V_{DD}+0.3$	V
Operating Temperature	$T_{OP}$	0	55.0	°C
Storage Temperature	$T_{STG}$	-55.0	125.0	°C

## 8 ELECTRICAL CHARACTERISTICS

Item	Sym.	Min.	Typ.	Max.	Unit	Condition
Operating Voltage	$V_{DD}$	2.4	-	5.5	V	
Standby Current	$I_{SBY}$	-	3 5	-	$\mu A$	$V_{DD}=3V$ $V_{DD}=4.5V$
Operating Current (Push-Pull Turn On)	$I_{OPR}$	-	6 12	-	mA	$V_{DD}=3V$ , no load $V_{DD}=4.5V$ , no load
Operating Current (Push-Pull Turn OFF)	$I_{OPR}$	-	4 5	-	mA	$V_{DD}=3V$ , no load $V_{DD}=4.5V$ , no load
Input pull low impedance of P0~P2	$R_i$	-	0.8M	-	$\Omega$	$V_{DD}=3V$
I/O port Drive Current	$I_{OD}$	-	4 8	-	mA	$V_{DD}=3V$ , $V_O=2.6V$ $V_{DD}=5V$ , $V_O=4.2V$
I/O port Sink Current	$I_{OS}$	-	6 10	-	mA	$V_{DD}=3V$ , $V_O=0.4V$ $V_{DD}=5V$ , $V_O=0.8V$
D/A Output Current	$I_{VO}$	2 2	3 3	4 4	mA	$V_{DD}=3V$ , $V_O=0.7V$ $V_{DD}=5V$ , $V_O=0.7V$
Push-Pull current	$I_{PP}$	-	70	-	mA	$V_{DD}=3V$ , Output 1Khz Sin wave.
Push-Pull current	$I_{PP}$	-	100	-	mA	$V_{DD}=4.5V$ , Ouput 1Khz Sin wave.
Oscillation Freq.	$F_{OSC}$	-	16.3 84	-	MHz	$V_{DD}=3V$
IR Carrier Frequency	Fir	-	38.5	-	KHz	

## **DISCLAIMER**

The information appearing in SONiX web pages (“this publication”) is believed to be accurate.

However, this publication could contain technical inaccuracies or typographical errors. The reader should not assume that this publication is error-free or that it will be suitable for any particular purpose. SONiX makes no warranty, express, statutory implied or by description in this publication or other documents which are referenced by or linked to this publication. In no event shall SONiX be liable for any special, incidental, indirect or consequential damages of any kind, or any damages whatsoever, including, without limitation, those resulting from loss of use, data or profits, whether or not advised of the possibility of damage, and on any theory of liability, arising out of or in connection with the use or performance of this publication or other documents which are referenced by or linked to this publication.

This publication was developed for products offered in Taiwan. SONiX may not offer the products discussed in this document in other countries. Information is subject to change without notice. Please contact SONiX or its local representative for information on offerings available. Integrated circuits sold by SONiX are covered by the warranty and patent indemnification provisions stipulated in the terms of sale only. The application circuits illustrated in this document are for reference purposes only. SONIX DISCLAIMS ALL WARRANTIES, INCLUDING THE WARRANTY OF MERCHANTABILITY OR FITNESS FOR ANY PURPOSE. SONIX reserves the right to halt production or alter the specifications and prices, and discontinue marketing the Products listed at any time without notice. Accordingly, the reader is cautioned to verify that the data sheets and other information in this publication are current before placing orders.

Products described herein are intended for use in normal commercial applications. Applications involving unusual environmental or reliability requirements, e.g. military equipment or medical life support equipment, are specifically not recommended without additional processing by SONIX for such application.