



SOD123W

Reel pack, SMD, 7"

Q1/T1-Q2/T3 standard product orientation

Orderable part number ending ,115 or X

Ordering code (12NC) ending 115

Rev. 1 — 18 February 2015

Packing information

1. Packing method

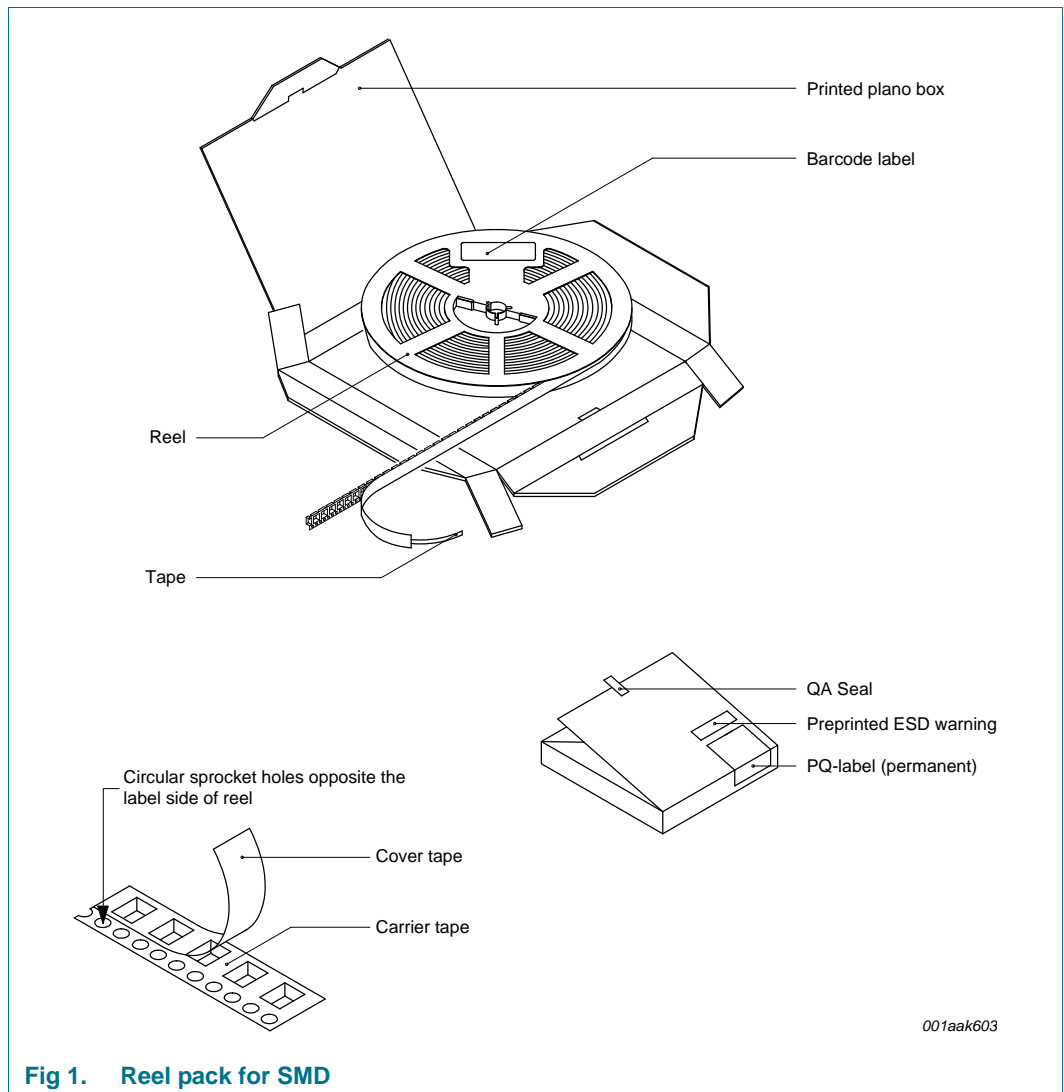

Reel pack, SMD, 7"
 Q1/T1-Q2/T3 standard product orientation
 Orderable part number ending ,115 or X
 Ordering code (12NC) ending 115

Table 1. Dimensions and quantities

Reel dimensions d × w (mm) [1]	SPQ/PQ (pcs) [2]	Reels per box	Outer box dimensions l × w × h (mm)
180 × 8	3000	1	185 × 185 × 16

[1] d = reel diameter; w = tape width.

[2] Packing quantity dependent on specific product type.

View ordering and availability details at [NXP order portal](#), or contact your local NXP representative.

2. Product orientation

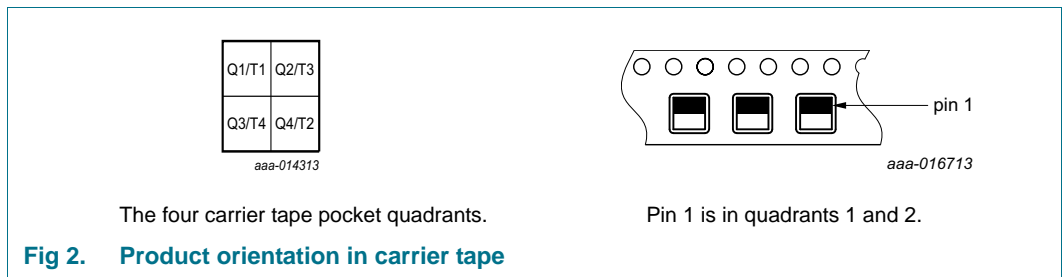

3. Carrier tape dimensions

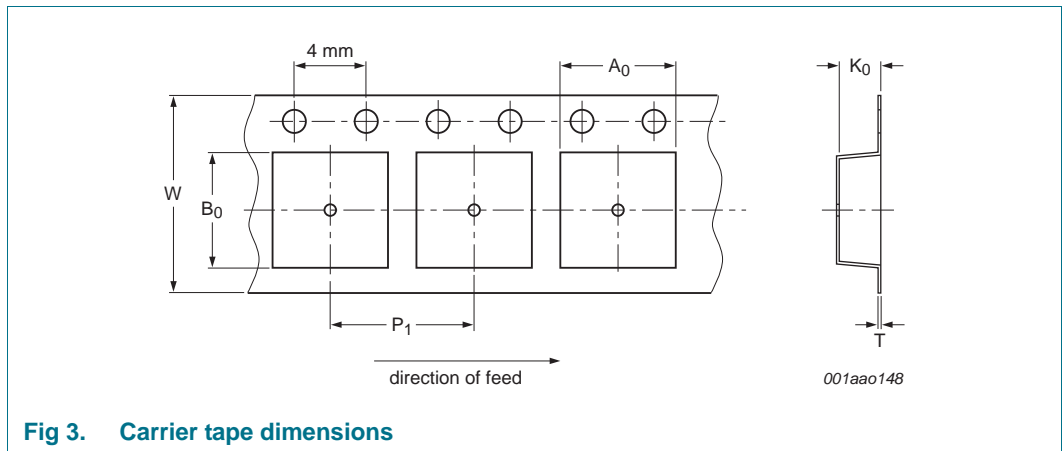

Table 2. Carrier tape dimensions

In accordance with IEC 60286-3.

A ₀ (mm)	B ₀ (mm)	K ₀ (mm)	T (mm)	P ₁ (mm)	W (mm)
2.05 ± 0.1	3.72 ± 0.05	1.25 ± 0.1	0.3 ± 0.05	4 ± 0.1	8 ± 0.1

4. Reel dimensions

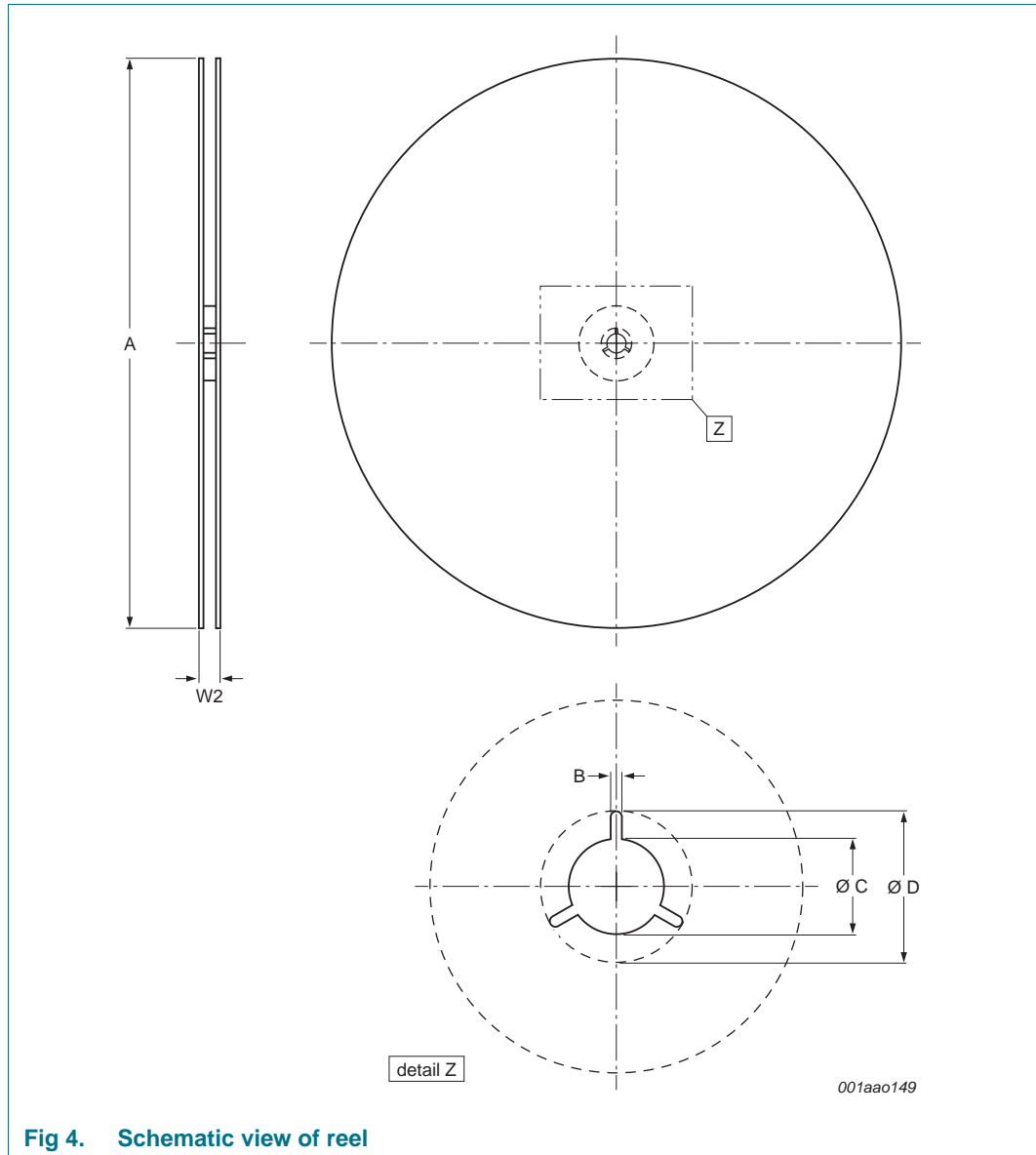

Fig 4. Schematic view of reel

Table 3. Reel dimensions
 In accordance with IEC 60286-3.

A [nom] (mm)	W2 [max] (mm)	B [min] (mm)	C [min] (mm)	D [min] (mm)
180	14.4	1.5	12.8	20.2

5. Barcode label

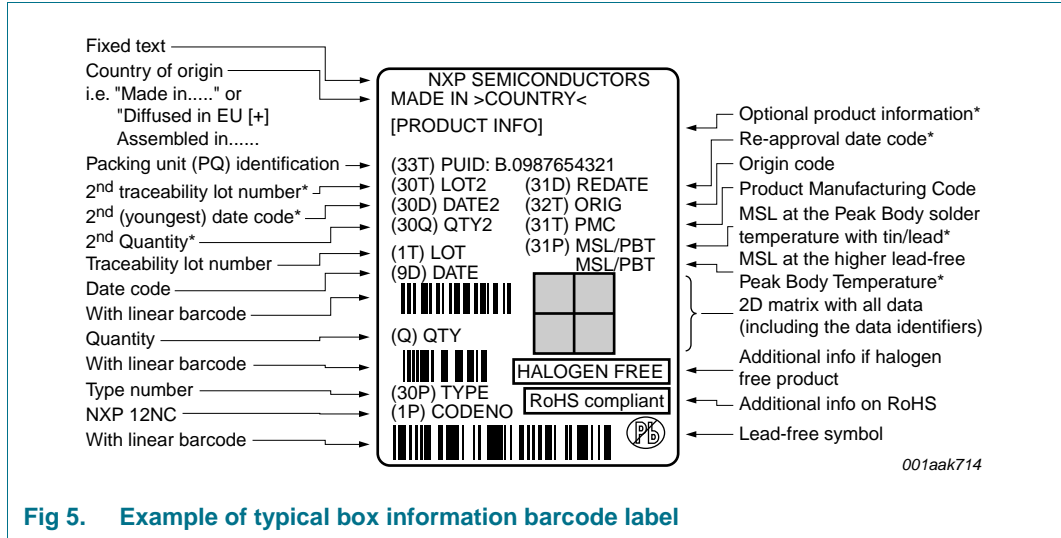

Fig 5. Example of typical box information barcode label

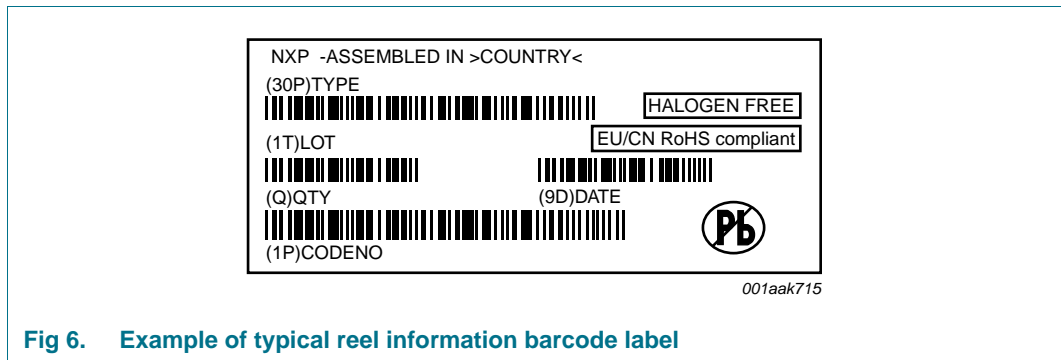

Fig 6. Example of typical reel information barcode label

Table 4. Barcode label dimensions

Box barcode label l x w (mm)	Reel barcode label l x w (mm)
100 x 75	36 x 75

Reel pack, SMD, 7"
Q1/T1-Q2/T3 standard product orientation
Orderable part number ending ,115 or X
Ordering code (12NC) ending 115

6. Revision history

Table 5. Revision history

Document ID	Release date	Packing document status	Change notice	Supersedes
SOD123W_115	20150218	Packing information	-	-

Limited warranty and liability

Information in this document is believed to be accurate and reliable. However, NXP Semiconductors does not give any representations or warranties, expressed or implied, as to the accuracy or completeness of such information and shall have no liability for the consequences of use of such information.

© NXP Semiconductors N.V. 2015.

All rights reserved.

For more information, please visit: <http://www.nxp.com>

For sales office addresses, please send an email to: salesaddresses@nxp.com

Date of release: 18 February 2015
Document identifier: SOD123W_115