

# Fast Recovery Rectifier

# SOF1A2F10HM

## Features

- For surface mounted applications
- Ideal for automated placement
- Low forward voltage drop
- High surge current capability
- RoHS Compliant
- Halogen Free



## Mechanical Data

- Case: SOD-123F molded plastic
- Molding compound, UL flammability classification rating 94V-0
- Terminals: Solder plated, solderable per MIL-STD-202, Method 208
- Polarity: Color band denotes cathode end

## Maximum Ratings (@T<sub>A</sub> = 25°C unless otherwise specified)

Characteristic	Symbol	SOF1A2F10HM	Units
Peak repetitive reverse voltage	V <sub>R</sub> RM	1000	V
RMS reverse voltage	V <sub>R</sub> MS	700	V
DC blocking voltage	V <sub>DC</sub>	1000	V
Maximum average forward output current	I <sub>F(AV)</sub>	1.2	A
Peak forward surge current, 8.3ms single half-sine-wave	I <sub>FSM</sub> @T <sub>J</sub> = 25°C	40	A

## Thermal Characteristics

Parameter	Symbol	SOF1A2F10HM	Units
Typical thermal resistance (Note 1)	R <sub>θJA</sub>	85	°C/W
	R <sub>θJC</sub>	23	
	R <sub>θJL</sub>	15	
Operating junction temperature range	T <sub>J</sub>	- 55 ---- + 150	°C
Storage temperature range	T <sub>STG</sub>	- 55 ---- + 150	°C

Note:

1. Device mounted on PCB with 10 mm x 20 mm x 0.1mm copper pad areas

## Fast Recovery Rectifier

## SOF1A2F10HM

### Electrical Characteristics (@T<sub>A</sub> = 25°C unless otherwise specified)

Parameter	Symbol	Test conditions	Typ.	Max.	Units
Maximum instantaneous forward voltage	V <sub>F</sub>	I <sub>F</sub> =1.2A	--	1.3	V
Maximum Reverse current	I <sub>R</sub>	Rated V <sub>R</sub> ,	@T <sub>A</sub> =25°C	10	μ A
			@T <sub>A</sub> =125°C	200	
Maximum Reverse Recovery Time	trr	I <sub>F</sub> =0.5A, I <sub>RM</sub> =1A, I <sub>R(REC)</sub> =0.25A	--	150	ns

## Fast Recovery Rectifier

SOF1A2F10HM

### Package Outline Dimensions(unit:mm)

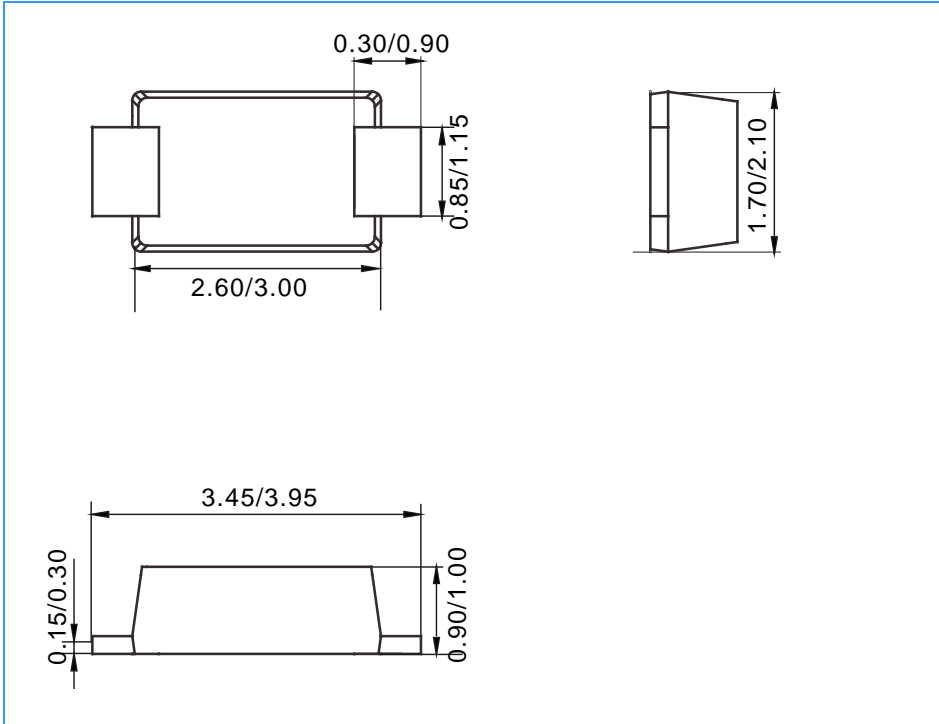

### Mounting Pad Layout(unit:mm)

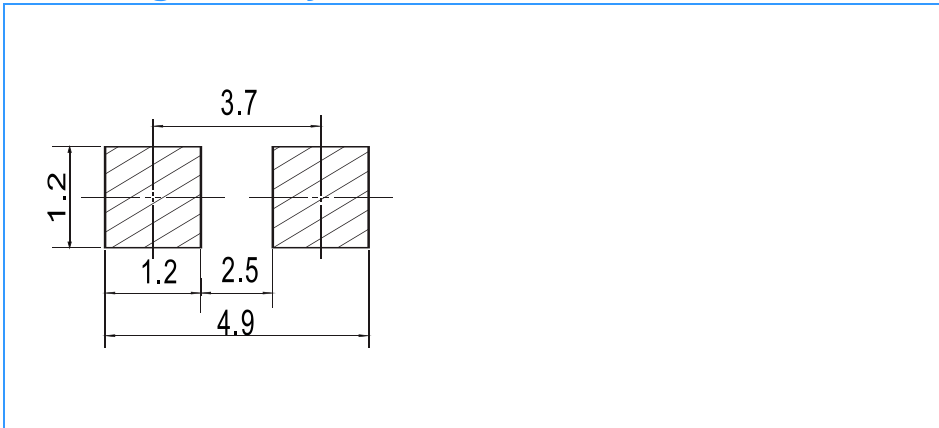

### Ordering Information

Part No.	Marking	Package	Shipping
SOF1A2F10HM	12FM	SOD-123F	10000 /Tape&Reel