

# SOT05CD

## Standard Capacitance TVS Array

The SOT05CD device is characterized by its high surge capability, low operating and clamping voltages, and fast response time. This makes it ideal for use as board level protection of sensitive semiconductor components. The dual-junction common-anode design allows the user to protect one bidirectional data line or two unidirectional lines.

It has been specifically designed to protect sensitive components which are connected to data and transmission lines from overvoltage caused by ESD(electrostatic discharge), CDE (Cable Discharge Events),and EFT (electrical fast transients).

### Features

- Small package for use in portable electronics
- Low leakage current
- Low clamping voltage
- Response Time is < 1 ns
- Protects one bidirectional line or two unidirectional lines
- Working voltages : 5V
- Solid-state silicon avalanche technology
- Device Meets MSL 1 Requirements
- ROHS compliant
- WeiPan technology

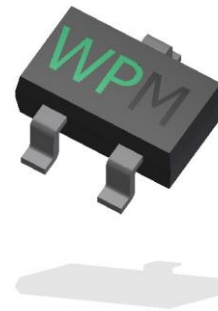

**SOT-23**

### Main applications

- Data lines
- Industrial Controls
- Cellular handsets AND accessories
- Portable instrumentation
- Peripherals
- Notebook Computers
- Set-Top Box
- Projection TV

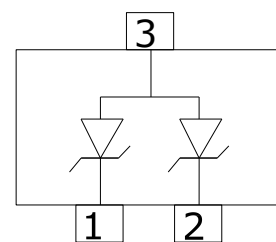

### Ordering Information

Device	Qty per Reel	Reel Size
SOT05CD	3000	7 Inch

“xx” =Working Peak Reverse Voltage

**Maximum ratings (Tamb=25°C Unless Otherwise Specified)**

Parameter	Symbol	Value	Unit
Peak Pulse Power (tp=8/20µs waveform)	PPPP	300	Watts
ESD Rating per IEC61000-4-2:	Contact	8	KV
	Air	15	
Lead Soldering Temperature	TL	260 (10 sec.)	°C
Operating Temperature Range	TI	-55 ~ 150	°C
Storage Temperature Range	TSTG	-55 ~ 150	°C

Maximum ratings are those values beyond which device damage can occur. Maximum ratings applied to the device are individual stress limit values (not normal operating conditions) and are not valid simultaneously. If these limits are exceeded, device functional operation is not implied, damage may occur and reliability may be affected.

\*Other voltages may be available upon request.

1. Non-repetitive current pulse, per Figure 1.

**Electrical characteristics (Tamb=25°C Unless Otherwise Specified)**

Device	VRWM	IR @ VRWM	VBR @ 1 mA	VC	Max IPP	Capacitance	
			(Volts)	@ 1 A		@ VR = 0 V, 1 MHz (pF)	
	(V)	(µA)	Min	(V)	(A)	Typ	Max
SOT05CD	5	1	6	9.8	17	150	250

Junction capacitance is measured in VR=0V, F=1MHz

Symbol	Parameter
VRWM	Working Peak Reverse Voltage
VBR	Breakdown Voltage @ IT
VC	Clamping Voltage @ IPP
IT	Test Current
IRM	Leakage current at VRWM
IPP	Peak pulse current
CO	Off-state Capacitance
CJ	Junction Capacitance

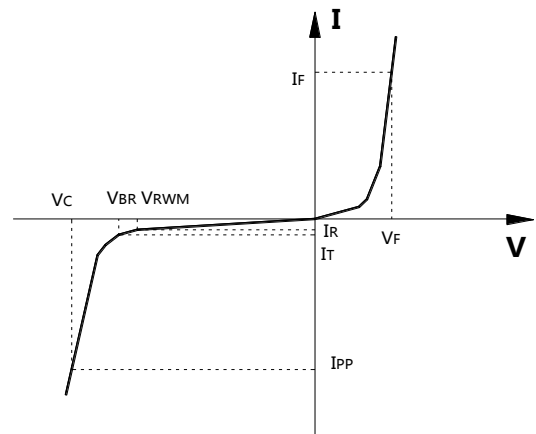

Typical electrical characterist applications

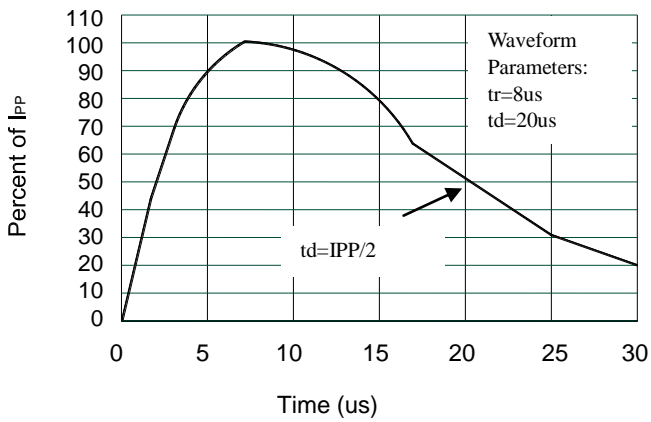

Pulse Waveform

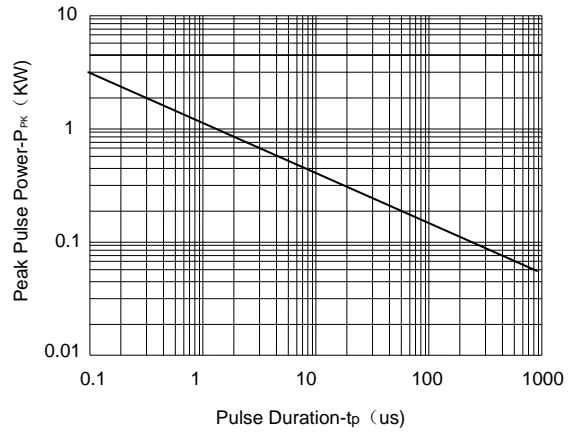

Non-Repetitive Peak Pulse Power vs. Pulse Time

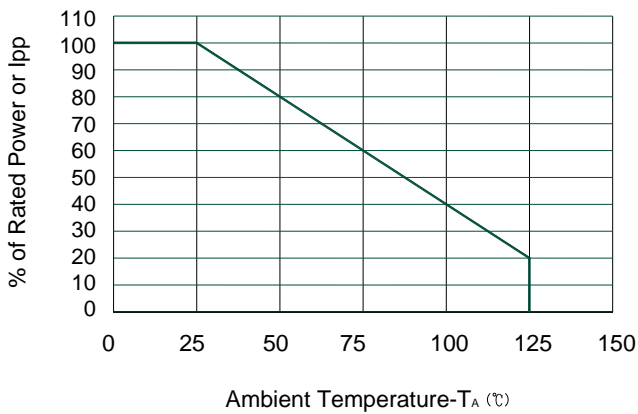

Power Derating Curve

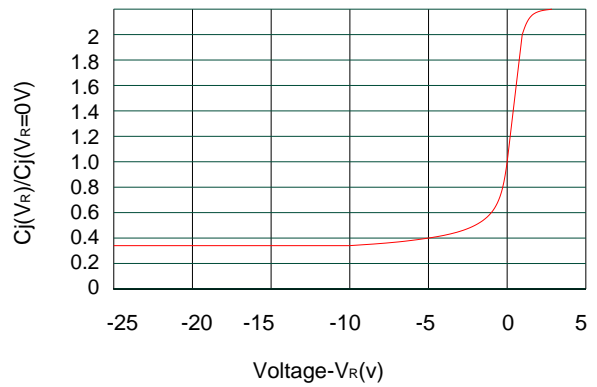

Junction Capacitance vs. Reverse Voltage

Typical applications

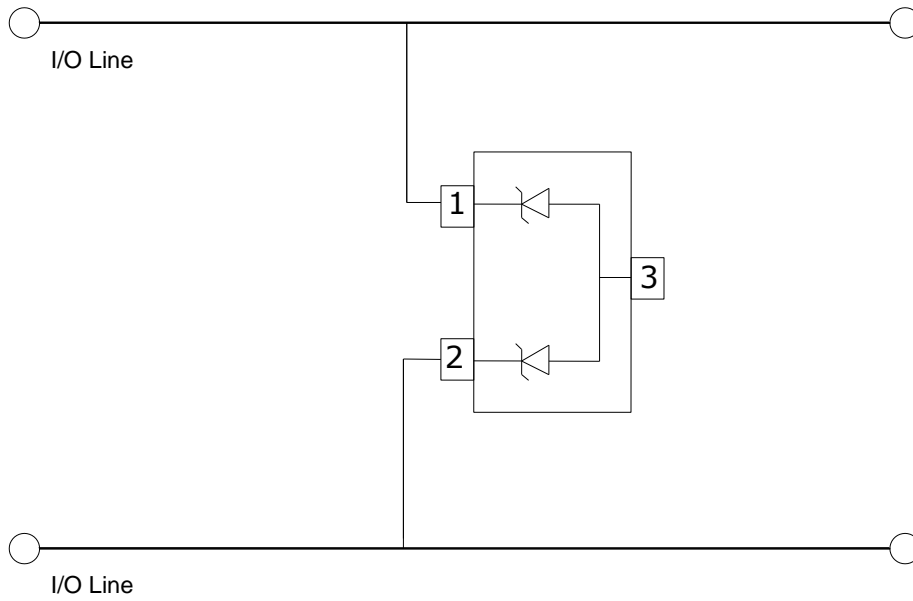

I/O Line Bi-direction Protection

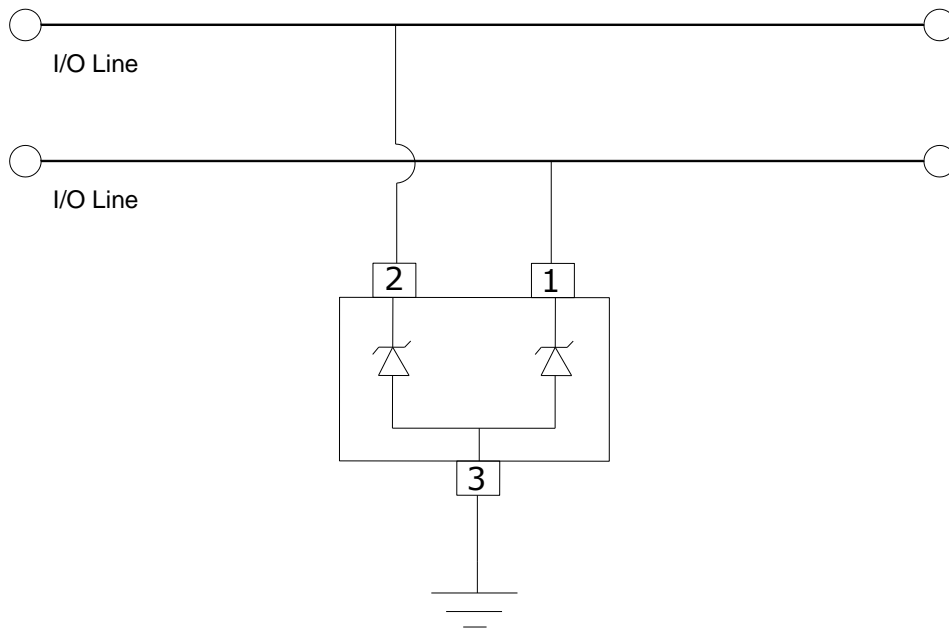

I/O Line uni-direction Protection

**Package Information**

**SOT23**

**Mechanical Data**

- Case: SOT23
- Case Material: Molded Plastic. UL Flammability

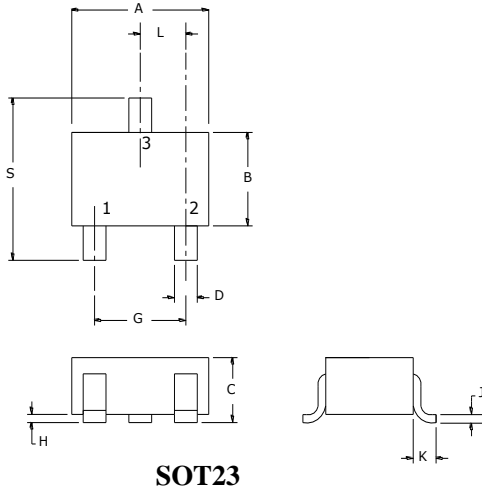

Dim	Millimeters		Inches	
	Min	Max	Min	Max
A	2.80	3.00	0.110	0.118
B	1.20	1.40	0.047	0.055
C	0.90	1.15	0.035	0.045
D	0.30	0.50	0.012	0.020
G	1.8	2.0	0.071	0.079
H	0.0	0.100	0	0.004
J	0.080	0.15	0.003	0.006
K	0.550REF		0.022REF	
L	0.95TYP		0.037TYP	
S	2.25	2.550	0.089	0.100

**Recommended Pad outline**

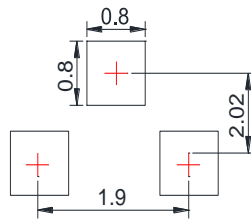

**SOT-23 Reel Dim**

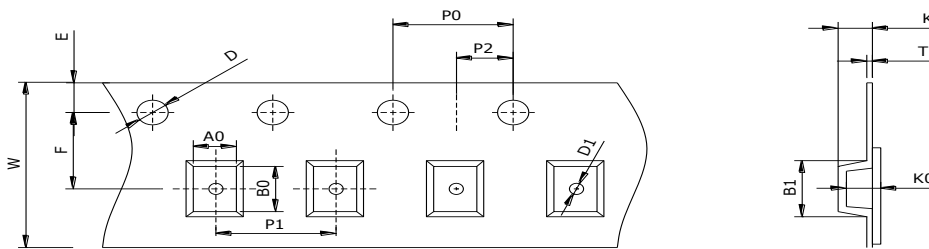

Package	Chip Size	Pocket Size B0×A0×K0(mm)	Tape Width	Reel Diameter	Quantity Per Reel	P0	P1
SOT-23	3.0×2.50×1.10	3.10×2.70×1.20	8mm	178mm(7")	3000	4mm	4mm
D0	D1	E	F	K	T	W	
1.5mm	1.0mm	1.75mm	3.5mm	1.10mm	0.2mm	8mm	