

### SP0504BAC, SP0508BAC, SP0516BAC

**NEW**

This family of avalanche diode arrays are designed for ESD protection and offered in an ultra small chip scale package.

The multi-channel devices are used to help protect sensitive digital or analog input circuits on data, signal, or control lines with unipolar voltage levels up to 5VDC.

The state-of-the-art structure is designed to suppress ESD and other transient over-voltage events to meet the International Electrotechnical Compaibility (EMC transient immunity standards IEC 61000-4-2 for Electrostatic Discharge Requirements).

The monolithic silicon devices are comprised of specially designed structures for transient voltage suppression (TVS). The size and shape of these structures has been tailored for transient protection. The low capacitance and clamp voltage are ideal for high speed signal line protection.

#### Ordering Information

PART NUMBER	DIODE CHANNELS	BUMPS	CS PACKAGE SIZE (MM)	QUANTITY PER REEL
SP0504BACT	4	6	1.804 x 1.154	3500
SP0508BACT	8	10	3.104 x 1.154	3500
SP0516BACT	16	20	3.104 x 2.454	3500

NOTE: Bump pitch is 0.65mm

#### Schematic

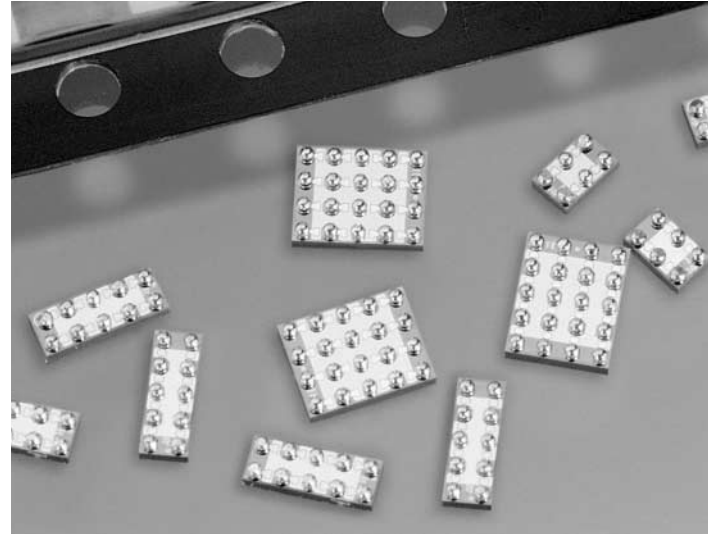
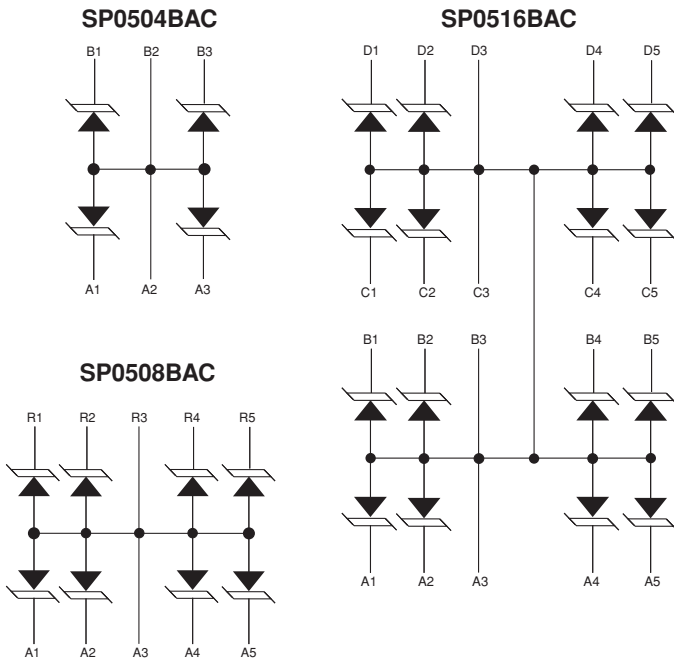

#### Features

- An Array of 4, 8 and 16 Avalanche Diodes in a ultra small Chip Scale Package (.65mm bump pitch)
- ESD Capability per HBM Standards
  - IEC 61000-4-2, Direct Discharge.....25kV (Level 4)
  - IEC 61000-4-2, Air Discharge.....30kV (Level 4)
  - MIL STD 883D (Method 3015.7) .....30kV
- Signal line protection for applications up to 5VDC
- Fast response time.....< 1ns
- Low input capacitance .....39pF Typical
- Low clamp voltage .....12V Typical
- Low input leakage.....10uA Max
- Operating temperature range .....- 40°C to 85°C

#### Applications

- Cell phone handsets
- Personal Digital Assistants (PDA)
- Portable handheld equipment (Laptop, Palmtop computers)
- Computer port, keyboard (USB1.1)
- Set-Top Box (Audio and Video Ports)
- PCMCIA cards

5 SILICON PROTECTION CIRCUITS

# Silicon Protection Circuits

TVS Avalanche Diode Array in a Unipolar Chip Scale Package

## SP0504BAC, SP0508BAC, SP0516BAC

ELECTRICAL SPECIFICATIONS  $T_A = 25^\circ\text{C}$  Unless Otherwise Specified

PARAMETER	TEST CONDITIONS	MIN	TYPICAL	MAX	UNITS
Reverse Standoff Voltage	$I = 10\mu\text{A}$	$\pm 5.5$	-	-	V
Reverse Standoff Leakage Current	$V = 5.5\text{V}$			10	$\mu\text{A}$
Signal Clamp Voltage					
Positive	$I = 10\text{mA}$	5.6	6.6	8.0	V
Negative	$I = 10\text{mA}$	- 1.2	- 0.8	- 0.4	V
Clamp Voltage during ESD					
MIL-STD-883D Method 3015	8kV Positive		12		V
	8kV Negative		- 8		V
ESD Test Level					
IEC-61000-4-2, Contact discharge		25			kV
MIL-STD-883D Method 3015 (HBM)		30			kV
Capacitance	2.5VDC @ 1Mhz		39		pF
Turn on/off Time			<1		ns
Temperature Range					
Operating		- 40		85	$^\circ\text{C}$
Storage		- 65		150	$^\circ\text{C}$

Typical Solder Reflow Thermal Profile (No Clean Flux)

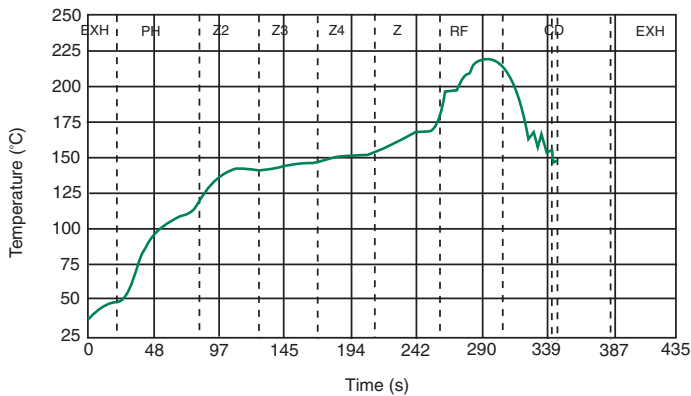

### PRINTED CIRCUIT BOARD RECOMMENDATIONS

Pad Size on PCB	0.300mm
Pad Shape	Round
Pad Definition	Non-Solder Mask Defined Pads (NSMD)
Solder Mask Opening	0.350mm
Solder Stencil Thickness	0.152mm
Solder Stencil Aperature Opening	0.360mm (sq)
Solder Flux Ratio	50/50
Solder Paste	No Clean
Board Trace Finish	OSP (Entek Cu Plus 106A)

### SP0504BAC, SP0508BAC, SP0516BAC

#### Outline Drawings

**SP0504BAC**

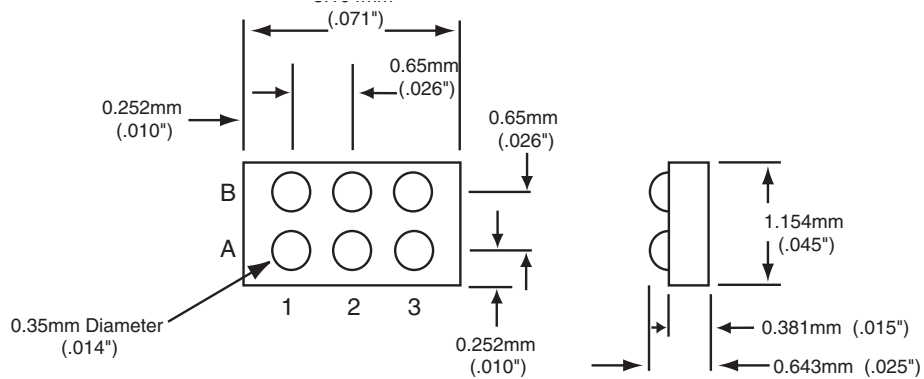

**SP0508BAC**

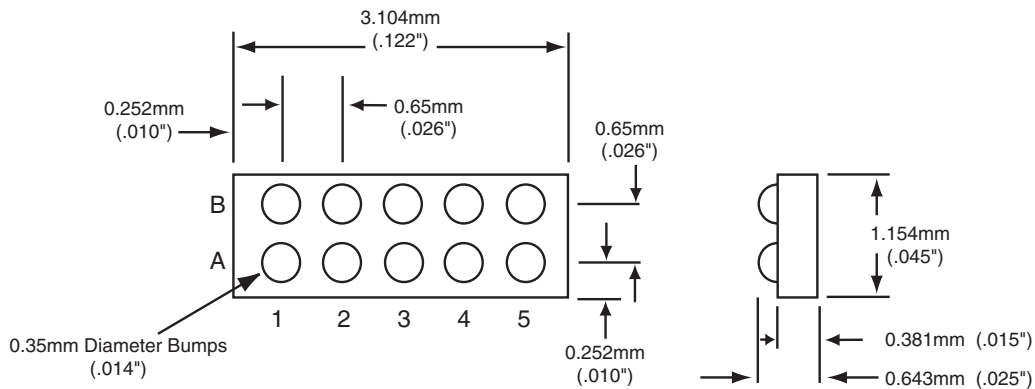

**SP0516BAC**

