

**Mechanical Date**

- Case: ITO-220
- Case Material: Molded Plastic, UL Flammability Classification Rating 94V-0
- Terminals: Matte Tin Finish annealed over copper Lead frame. Solderable per MIL-STD-202
- Weight: 1.1 J grams (approximate)

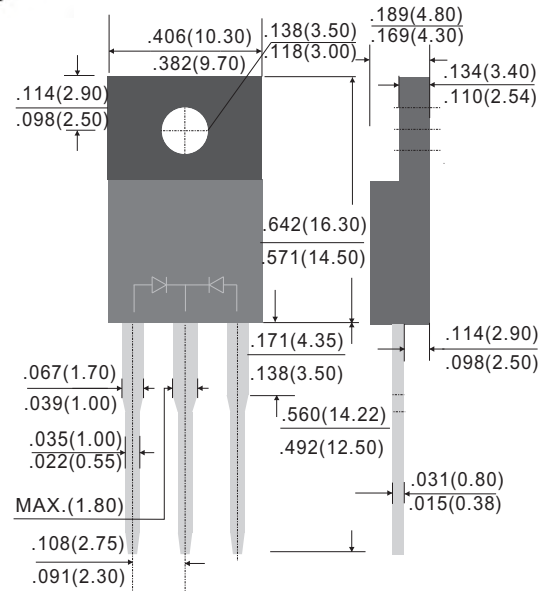

**ITO-220**



Dimensions in inches and (millimeters)

**Features**

- Guard Ring for over voltage Protection
- High forward surge capability
- High frequency operation
- Component in accordance to RoHS 2002/95/EC
- **Pb-Free package is available**  
RoHS product for packing code suffix "G"  
Halogen free product for packing code suffix "H"

MAXIMUM RATINGS (TA=25°C unless otherwise noted)							
PARAMETER	SYMBOL	SP1040C	SP1060C	SP10100C	SP10150C	SP10200C	UNIT
Maximum repetitive peak reverse voltage	V <sub>RRM</sub>	40	60	100	150	200	V
Maximum RMS voltage	V <sub>RMS</sub>	28	42	70	105	140	V
Maximum DC blocking voltage	V <sub>DC</sub>	40	60	100	150	200	V
Maximum average forward rectified current (Total) (Per Leg)	I <sub>F</sub>	10 5					A
Peak forward surge current, 8.3ms single half sine-wave superimposed on rated load	I <sub>FSM</sub>	100.0					A
Maximum Instantaneous Forward Voltage IF=5A @ 25°C	V <sub>F</sub>	0.55	0.70	0.85	0.92		V
Maximum DC Reverse Current @ Tc=25°C at Rated DC Blocking Voltage @ Tc=125°C	I <sub>R</sub>	0.5 20		0.2 5			mA
Typical Junction Capacitance(NOTE1)	C <sub>j</sub>	250	200	150			pF
Typical Thermal Resistance	R <sub>θJC</sub>	3					°C/W
Operating Temperature Range	T <sub>J</sub>	-55 to +125			-55 to +150		°C
Storage Temperature Range	T <sub>STG</sub>	-55 to +150					°C

NOTES:1.Measured at 1.0MHZ and applied reverse voltage of 4.0V DC

FIG. 1-TYPICAL FORWARD CURRENT DERATING CURVE

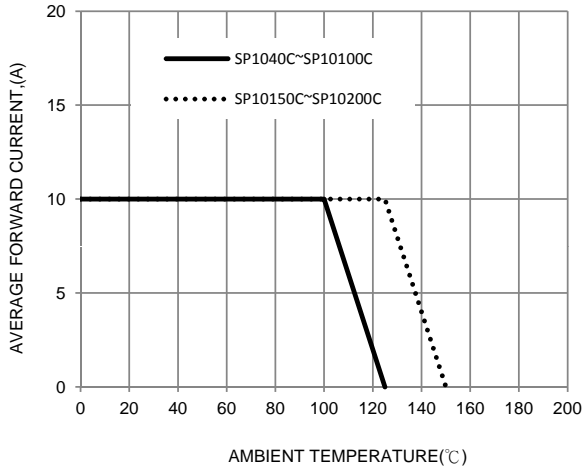

FIG. 2-TYPICAL FORWARD CHARACTERISTICS

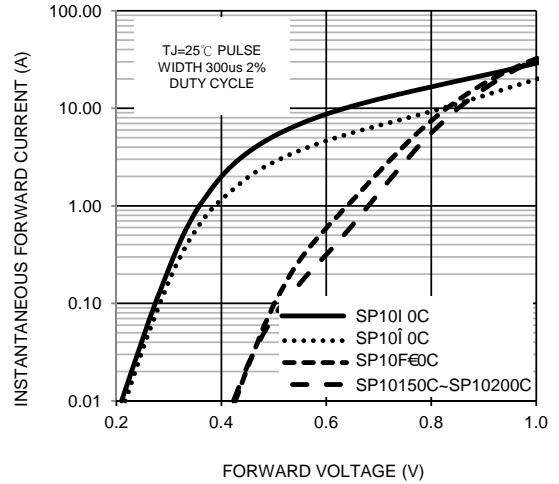

FIG. 3-MAXIMUM NON-REPETITIVE FORWARD SURGE CURRENT

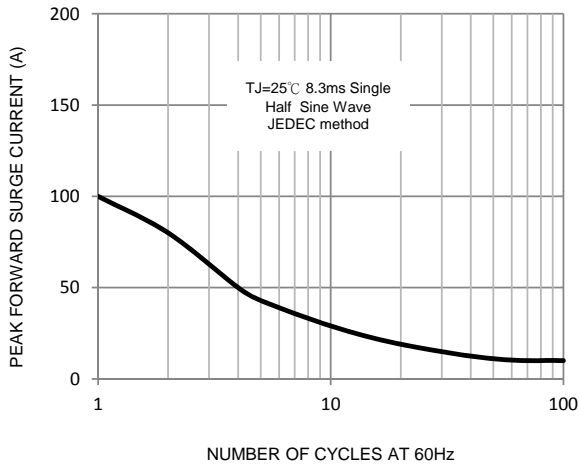

FIG. 4-TYPICAL REVERSE CHARACTERISTICS

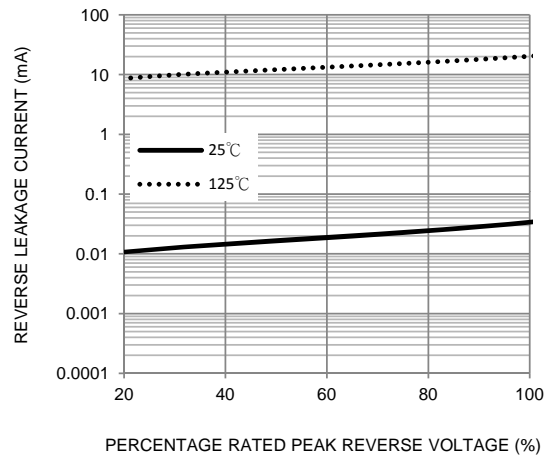

FIG. 5-TYPICAL JUNCTION CAPACITANCE

