

# HITACHI

KAOHSIUNG HITACHI  
ELECTRONICS CO.,LTD  
P.O. BOX 26-27  
2,13TH EAST ST. K.E.P.Z..  
KAOHSIUNG TAIWAN R.O.C.  
TEL: (07) 8215811(7 LINE)  
FAX: (07) 821-5815

FOR MESSRS: \_\_\_\_\_

DATE: May.13,2008

## CUSTOMER'S ACCEPTANCE SPECIFICATIONS

### SP10Q010-TZA

### C O N T E N T S

No.	ITEM	SHEET No.	PAGE
1	COVER	7B64PS 2701- SP10Q010-TZA-6	1-1/1
2	RECORD OF REVISION	7B64PS 2702- SP10Q010-TZA-6	2-1/2~2/2
3	GENERAL SPECIFICATIONS	7B64PS 2703- SP10Q010-TZA-6	3-1/1
4	ABSOLUTE MAXIMUM RATINGS	7B64PS 2704- SP10Q010-TZA-6	4-1/1
5	ELECTRICAL CHARACTERISTICS	7B64PS 2705- SP10Q010-TZA-6	5-1/2~2/2
6	OPTICAL CHARACTERISTICS	7B64PS 2706- SP10Q010-TZA-6	6-1/2~2/2
7	BLOCK DIAGRAM	7B64PS 2707- SP10Q010-TZA-6	7-1/1
8	INTERFACE TIMING CHART	7B64PS 2708- SP10Q010-TZA-6	8-1/3~3/3
9	OUTLINE DIMENSIONS	7B63PS 2709- SP10Q010-TZA-6 7B64PS 2709- SP10Q010-TZA-6	9-1/2 9-2/2
10	QUALITY STANDARD	7B64PS 2710- SP10Q010-TZA-6	10-1/3~3/3
11	PRECAUTION IN DESIGN	7B64PS 2711- SP10Q010-TZA-6	11-1/3~3/3
12	DESIGNATION OF LOT MARK	7B64PS 2712- SP10Q010-TZA-6	12-1/1
13	PRECAUTION FOR USE	7B64PS 2713- SP10Q010-TZA-6	13-1/1
14	DIGITIZER TECHNICAL SPECIFICATION	7B64PS 2714- SP10Q010-TZA-6	14-1/4~4/4

- \* When product will be discontinued, customer will be informed by HITACHI with twelve months prior announcement.
- \* This product is inhibited to apply in any life support instrument.

ACCEPTED BY: \_\_\_\_\_

PROPOSED BY: Dan Cheng

KAOHSIUNG HITACHI ELECTRONICS CO.,LTD.	Sh. No.	7B64PS 2701- SP10Q010-TZA-6	PAGE	1-1/1
---	------------	-----------------------------	------	-------

## RECORD OF REVISION

DATE	SHEET No.	SUMMARY																		
May.13,'08	7B64PS 2714- SP10Q010-TZA-6 PAGE 14-1/4	<p>14.2.1 INPUT METHOD &amp; ACTUATION FORCE Changed :</p> <table border="1" style="width: 100%; border-collapse: collapse; margin-bottom: 10px;"> <thead> <tr> <th style="width: 33%;">INPUT METHOD</th> <th style="width: 33%;">ACTUATION FORCE</th> <th style="width: 34%;">COMMENT</th> </tr> </thead> <tbody> <tr> <td style="text-align: center;">Pen</td> <td style="text-align: center;">10~50 g</td> <td style="text-align: center;">R0.8mm, Poly-acetal Pen</td> </tr> <tr> <td style="text-align: center;">Finger</td> <td style="text-align: center;">10~50 g</td> <td style="text-align: center;">R8.0mm, Silicone Rubber</td> </tr> </tbody> </table> <p style="text-align: center;">↓</p> <table border="1" style="width: 100%; border-collapse: collapse;"> <thead> <tr> <th style="width: 33%;">INPUT METHOD</th> <th style="width: 33%;">ACTUATION FORCE</th> <th style="width: 34%;">COMMENT</th> </tr> </thead> <tbody> <tr> <td style="text-align: center;">Pen</td> <td style="text-align: center;">1.2N max.</td> <td style="text-align: center;">R0.8mm, Poly-acetal Pen</td> </tr> <tr> <td style="text-align: center;">Finger</td> <td style="text-align: center;">1.2N max.</td> <td style="text-align: center;">R8.0mm, Silicone Rubber</td> </tr> </tbody> </table>	INPUT METHOD	ACTUATION FORCE	COMMENT	Pen	10~50 g	R0.8mm, Poly-acetal Pen	Finger	10~50 g	R8.0mm, Silicone Rubber	INPUT METHOD	ACTUATION FORCE	COMMENT	Pen	1.2N max.	R0.8mm, Poly-acetal Pen	Finger	1.2N max.	R8.0mm, Silicone Rubber
INPUT METHOD	ACTUATION FORCE	COMMENT																		
Pen	10~50 g	R0.8mm, Poly-acetal Pen																		
Finger	10~50 g	R8.0mm, Silicone Rubber																		
INPUT METHOD	ACTUATION FORCE	COMMENT																		
Pen	1.2N max.	R0.8mm, Poly-acetal Pen																		
Finger	1.2N max.	R8.0mm, Silicone Rubber																		

## RECORD OF REVISION

DATE	SHEET No.	SUMMARY								
Feb.12,'03	7B64PS 2709- SP10Q010-TZA-2 PAGE 9-1/2	9. OUTLINE DIMENSIONS Note 4. Unmark Tolerance : $\pm 0.2\text{mm}$ ↓ Revised Note 4. Unmarked Tolerance : $\pm 0.5\text{mm}$								
Apr.02,'03	7B64PS 2707- SP10Q010-TZA-3 PAGE 7-1/1	7. BLOCK DIAGRAM Revised BLOCK DIAGRAM.								
	7B64PS 2709- SP10Q010-TZA-3 PAGE 9-1/2	9. OUTLINE DIMENSIONS Revised pixel of scan.								
May.09,'03	7B64PS 2707- SP10Q010-TZA-4 PAGE 7-1/1	7. BLOCK DIAGRAM Revised scanning pixel of Y side								
	7B64PS 2709- SP10Q010-TZA-4 PAGE 9-1/2	9. OUTLINE DIMENSIONS Revised pixel of scan.								
Aug.25,'03	7B64PS 2706- SP10Q010-TZA-5 PAGE 6-1/2	6.1 OPTICAL CHARACTERISTICS OF LCD K : (8) → (4)								
	7B63PS 2709- SP10Q010-TZA-5 PAGE 9-1/2	9. OUTLINE DIMENSIONS 1. Changed the FPC exiting the module from the "center" to the rear side of module. 2. Changed dimension between FPC (upper side) to module from (5.0) to (2.0).								
May.13,'08	7B64PS 2714- SP10Q010-TZA-6 PAGE 14-1/4	14.1.2 OPERATING CONDITIONS Changed : <table border="1" style="width: 100%; margin: 5px 0;"> <thead> <tr> <th style="width: 30%;">ITEM</th> <th style="width: 70%;">SPECIFICATIONS</th> </tr> </thead> <tbody> <tr> <td>ACTUATION FORCE</td> <td>10~50 g(R0.8mm,Poly-acetal Pen)</td> </tr> </tbody> </table> <p style="text-align: center;">↓</p> <table border="1" style="width: 100%; margin: 5px 0;"> <thead> <tr> <th style="width: 30%;">ITEM</th> <th style="width: 70%;">SPECIFICATIONS</th> </tr> </thead> <tbody> <tr> <td>ACTUATION FORCE</td> <td>1.2N max(R0.8mm,Poly-acetal Pen)</td> </tr> </tbody> </table>	ITEM	SPECIFICATIONS	ACTUATION FORCE	10~50 g(R0.8mm,Poly-acetal Pen)	ITEM	SPECIFICATIONS	ACTUATION FORCE	1.2N max(R0.8mm,Poly-acetal Pen)
ITEM	SPECIFICATIONS									
ACTUATION FORCE	10~50 g(R0.8mm,Poly-acetal Pen)									
ITEM	SPECIFICATIONS									
ACTUATION FORCE	1.2N max(R0.8mm,Poly-acetal Pen)									

### 3. GENERAL SPECIFICATIONS

(1) Part Name	SP10Q010-TZA
(2) Module Size	94.7 (W)mm x 73.3 (H)mm x 6.5 (D) mm
(3) Active Area	76.785(W)mm x 57.585(H)mm
(4) Dot Pitch	0.24 (W)mm x 0.24 (H)mm
(5) Dot Size	0.225 (W)mm x 0.225 (H)mm
(6) Resolution	320 (W) x 240 (H) dots
(7) Duty Ratio	1/242
(8) Bias Ratio	1/13
(9) LCD Type	Transflective type B/W F-STN (Positive Mode)
(10) Viewing Direction	6 O'clock
(11) Backlight	LED(Color : White)
(12) Touch Panel	Analog Resistive Linearity : $\pm 1.5\%$ Hardness : 2H Transparency : 80% Surface Type : Anti-Glare

## 4. ABSOLUTE MAXIMUM RATINGS

### 4.1 ELECTRICAL ABSOLUTE MAXIMUM RATINGS.

VSS=0V:STANDARD

ITEM	SYMBOL	MIN.	MAX.	UNIT	COMMENT
Power Supply for Logic	VDD-VSS	-0.3	7.0	V	
Power Supply for LC Drive	VLCD	0	30.0	V	
Input Voltage	Vi	-0.3	VDD+0.3	V	(Note 1,2)

Note 1 :  $\overline{DOFF}$  , FLM , CL1, CL2 , D0~D3 , M.

Note 2 : Make certain you are grounded when handling LCM.

### 4.2 ENVIRONMENTAL ABSOLUTE MAXIMUM RATINGS.

I T E M	OPERATING		STORAGE		COMMENT
	MIN.	MAX.	MIN.	MAX.	
Ambient Temperature	-20°C	70°C	-30°C	80°C	(Note 2,3,4,7)
Humidity	(Note 1)		(Note 1)		Without condensation
Vibration	-	2.45 m/s <sup>2</sup>	-	11.76 m/s <sup>2</sup> (Note 5)	1 h max . (Note 5)
Shock	-	29.4 m/s <sup>2</sup>	-	490 m/s <sup>2</sup> (Note 5)	XYZ directions 11ms (Note 5)
Corrosive Gas	Not acceptable		Not acceptable		

Note 1 :  $T_a \leq 40^\circ\text{C}$  : 85%RH max.

$T_a > 40^\circ\text{C}$  : Absolute humidity must be lower than the humidity of 85%RH at 40°C

Note 2 :  $T_a$  at  $-30^\circ\text{C} < 48\text{h}$  , at  $80^\circ\text{C} < 168\text{h}$ .

Note 3 : Background color changes slightly depending on ambient temperature .  
This phenomenon is reversible.

Note 4 : This LCM will be operated under low temperature , and the response time will be slower.

Note 5 : This module should be operated normally after finish the test.

Note 6 : The module do not have mounting hole.

It should be fixed by the way of sandwiching-like method.

Note 7 : Regarding ambient temperature of T/P is according to page 14-1/4 of this document.

## 5. ELECTRICAL CHARACTERISTICS

### 5.1 ELECTRICAL CHARACTERISTICS OF LCD

ITEM	SYMBOL	CONDITION	MIN.	TYP.	MAX.	UNIT
Power Supply Voltage for Logic	VDD-VSS	-	2.5	3.3	4.5	V
Power Supply Voltage for LCD Driving	VLCD-VSS	-	-	-	30.0	V
Input Voltage (Note 1)	VI	H level	0.8VDD	-	VDD	V
		L level	0	-	0.2VDD	V
Power Supply Current For Logic , (Note 2)	IDD	VDD-VSS=3.3V VLCD-VSS=(22.5)V	-	(2.38)	-	mA
Power Supply Current for LC Driving , (Note 2)	ILCD Note (4)	VDD-VSS=3.3V VLCD-VSS=(22.5)V	-	(1.5)	-	mA
Recommended LC Driving Voltage (Note 3)	VLCD-VSS	Ta= 0°C , $\phi=0^\circ$	-	(24.5)	-	V
		Ta=25°C , $\phi=0^\circ$	-	(22.5)	-	V
		Ta=50°C , $\phi=0^\circ$	-	(20.5)	-	V
Frame Frequency (Note 4)	fFLM	-	70	75	80	Hz

Note 1 : DOFF , FLM , CL1 , CL2, D0~D3.

Note 2 : fFLM=75Hz , Test pattern is all "Q".

VLCD-VSS=(22.5)V, Ta=25°C.

Note 3 : Recommended LC driving voltage fluctuate about  $\pm 1.0V$  by each module.  
Test pattern is all "Q".

Note 4 : Need to make sure of flickering and rippling of display when setting the frame frequency in your set.

## 5.2 ELECTRICAL CHARACTERISTICS OF LED BACKLIGHT

Ta=25°C (Display off)

ITEM	SYMBOL	CONDITION	MIN.	TYP.	MAX.	UNIT
Power Supply Voltage for LED	VLED	-	-	5.0	5.2	V
Power Supply Current for LED	ILED	VLED=5.0V	-	110	120 (Note 1)	mA

Note 1 : The ILED changes depending on ambient temperature.

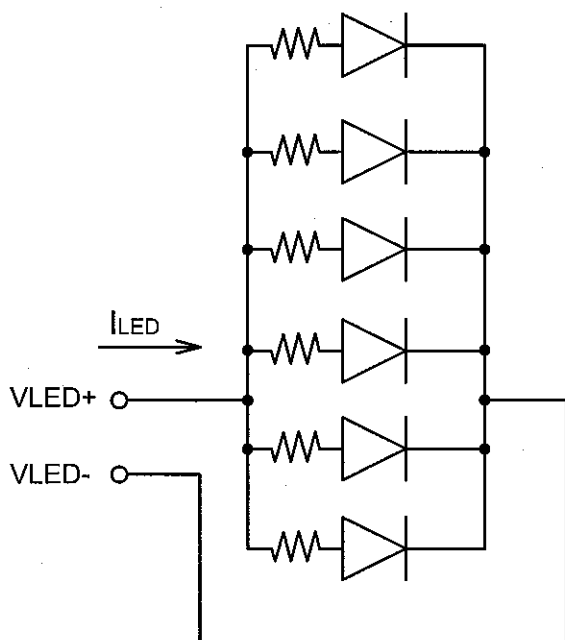
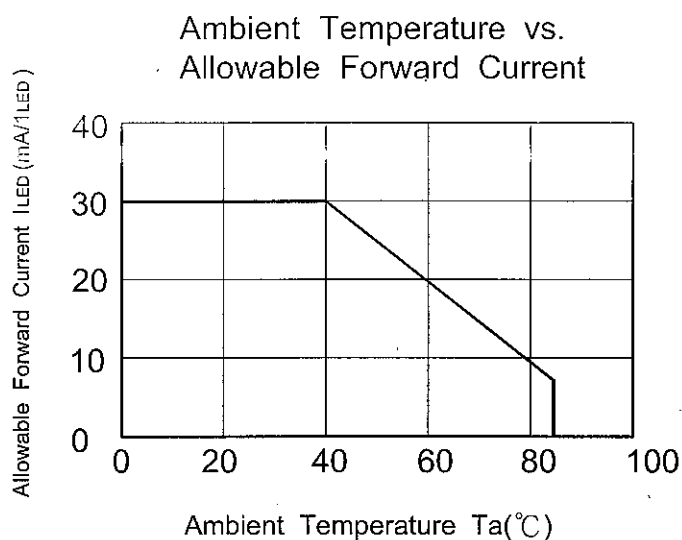

# 6. OPTICAL CHARACTERISTICS

## 6.1 OPTICAL CHARACTERISTICS OF LCD

Ta=25 °C (Backlight off)

ITEM	SYMBOL	CONDITION	MIN.	TYP.	MAX.	UNIT	NOTE
Viewing Angle	$\phi_2-\phi_1$	$K \geq 2.0$	-	80	-	deg.	1,2
Contrast Ratio	K	$\phi=0^\circ, \theta=0^\circ$	-	(4)	-	-	3
Response Time (Rise)	tr	$\phi=0^\circ, \theta=0^\circ$	-	(150)	-	ms	4
Response Time (Fall)	tf	$\phi=0^\circ, \theta=0^\circ$	-	(350)	-	ms	4

Note 1 : Definition of  $\theta$  and  $\phi$  (Normal)

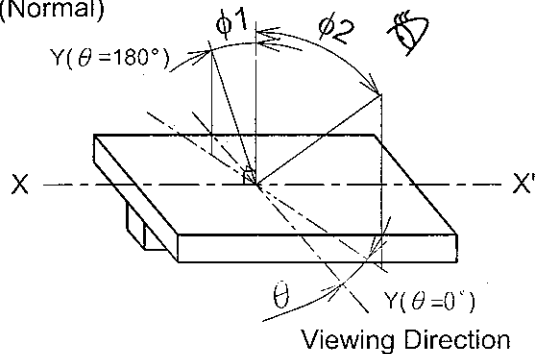

(Measure condition by HITACHI)  
Note 3 : Definition of contrast "K"

$$K = \frac{\text{Brightness on non-selected dot (B1)}}{\text{Brightness on selected dot (B2)}}$$

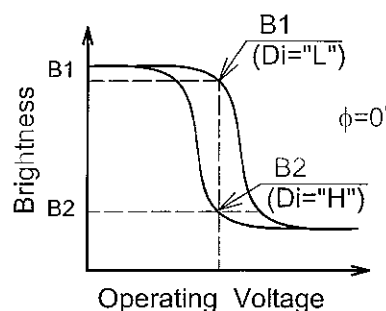

Note 2 : Definition of viewing angle  $\phi_1$  and  $\phi_2$

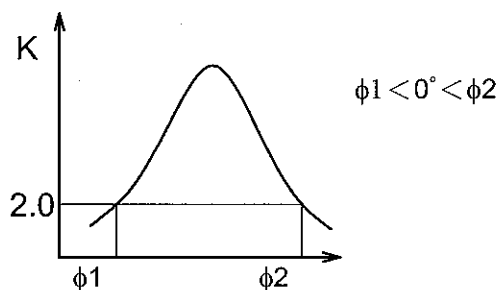

Contrast ratio K vs viewing angle  $\phi$

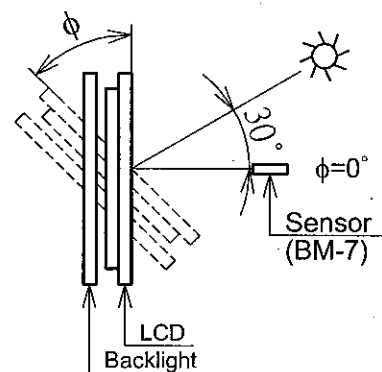

Note 4 : Definition of optical response

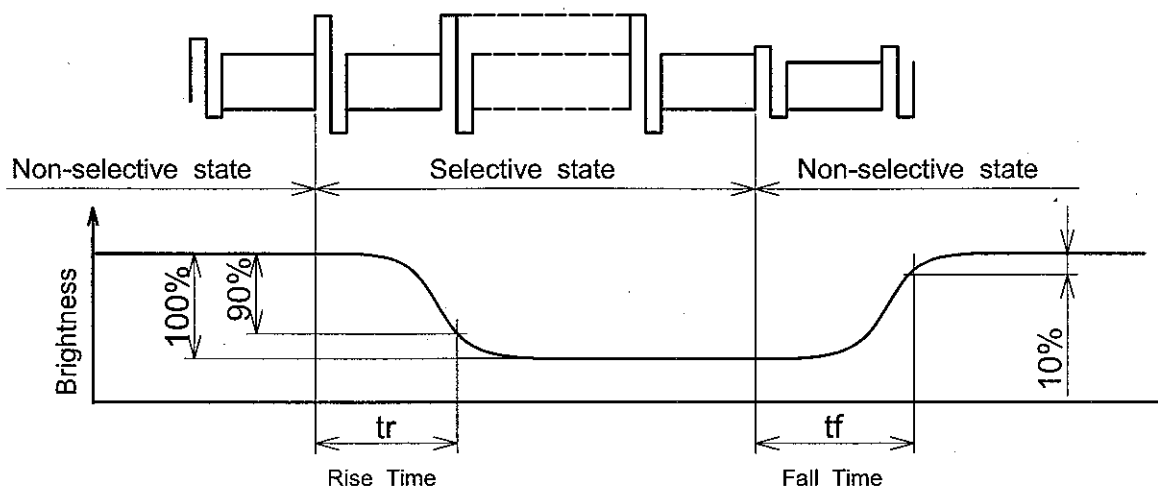



## 6.2 OPTICAL CHARACTERISTICS OF BACKLIGHT

(LCM, BACKLIGHT ON, Ta=25°C)

ITEM	MIN.	TYP.	MAX.	UNIT	NOTE
Brightness Uniformity	-	-	±35	%	(Note 1,2)
Brightness	-	50	-	cd/m <sup>2</sup>	I <sub>LED</sub> =110 mA

Note 1 : Measure of the following 9 places on the display.

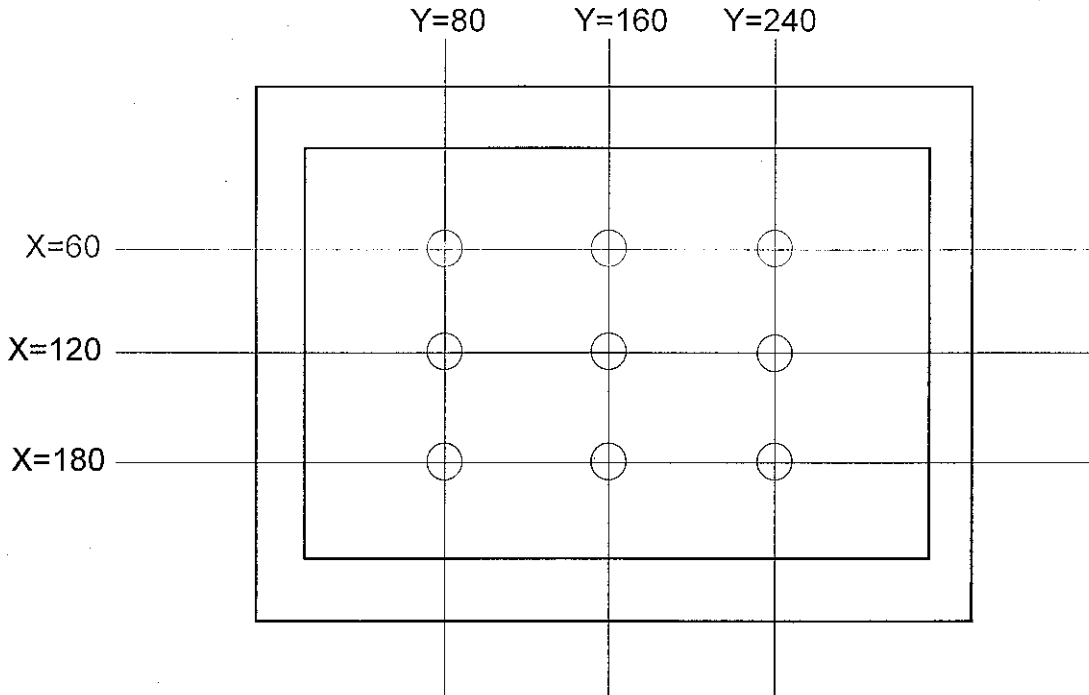

Note 2 : Definition of brightness tolerance.

$$\left( \frac{\text{Max or Min Brightness} - \text{Average Brightness}}{\text{Average Brightness}} \right) \times 100\%$$

# 7. BLOCK DIAGRAM

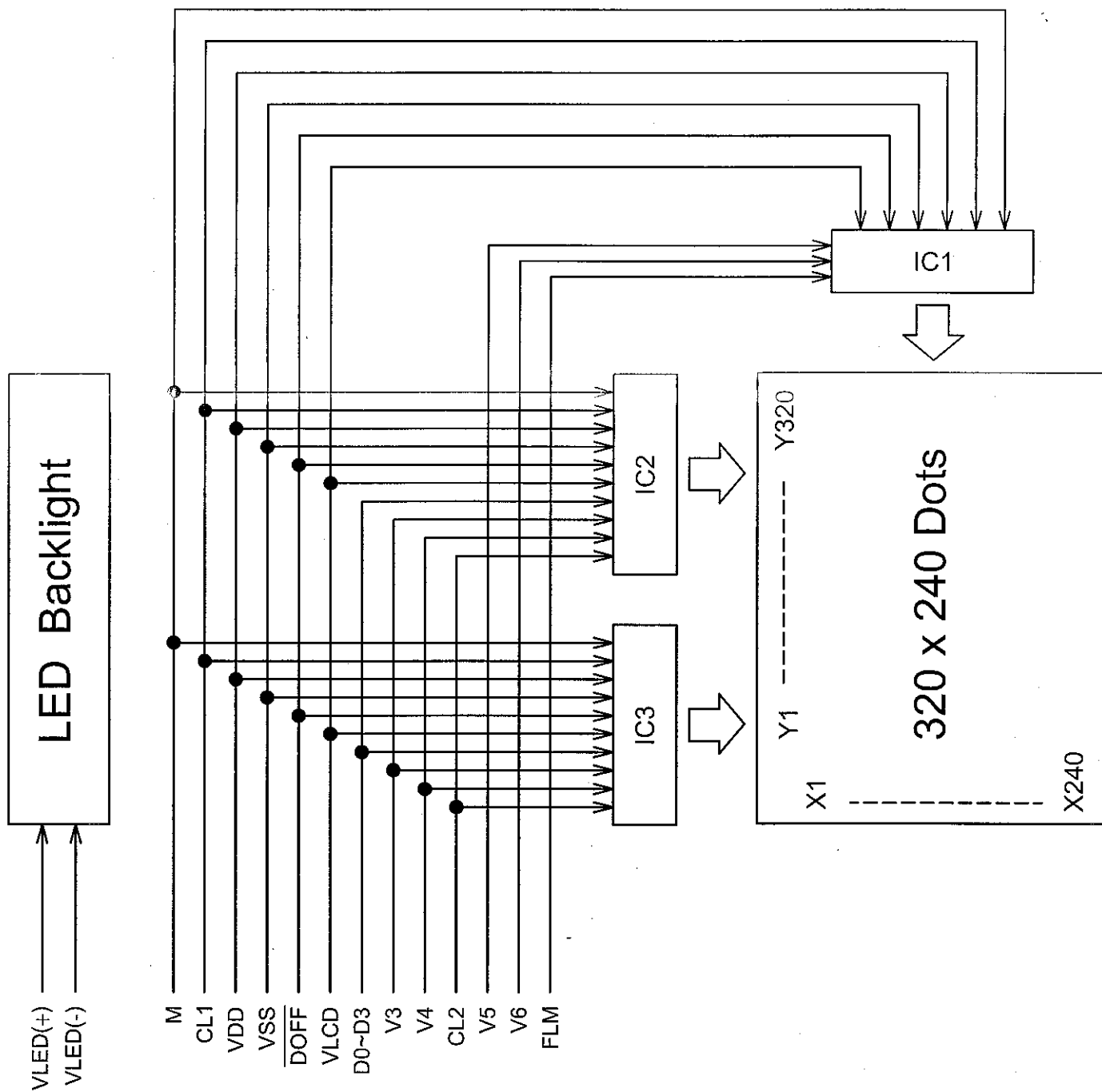

# 8. INTERFACE TIMING

## 8.1 TIMING CHART (4-BITS PARALLEL DATA INPUT)

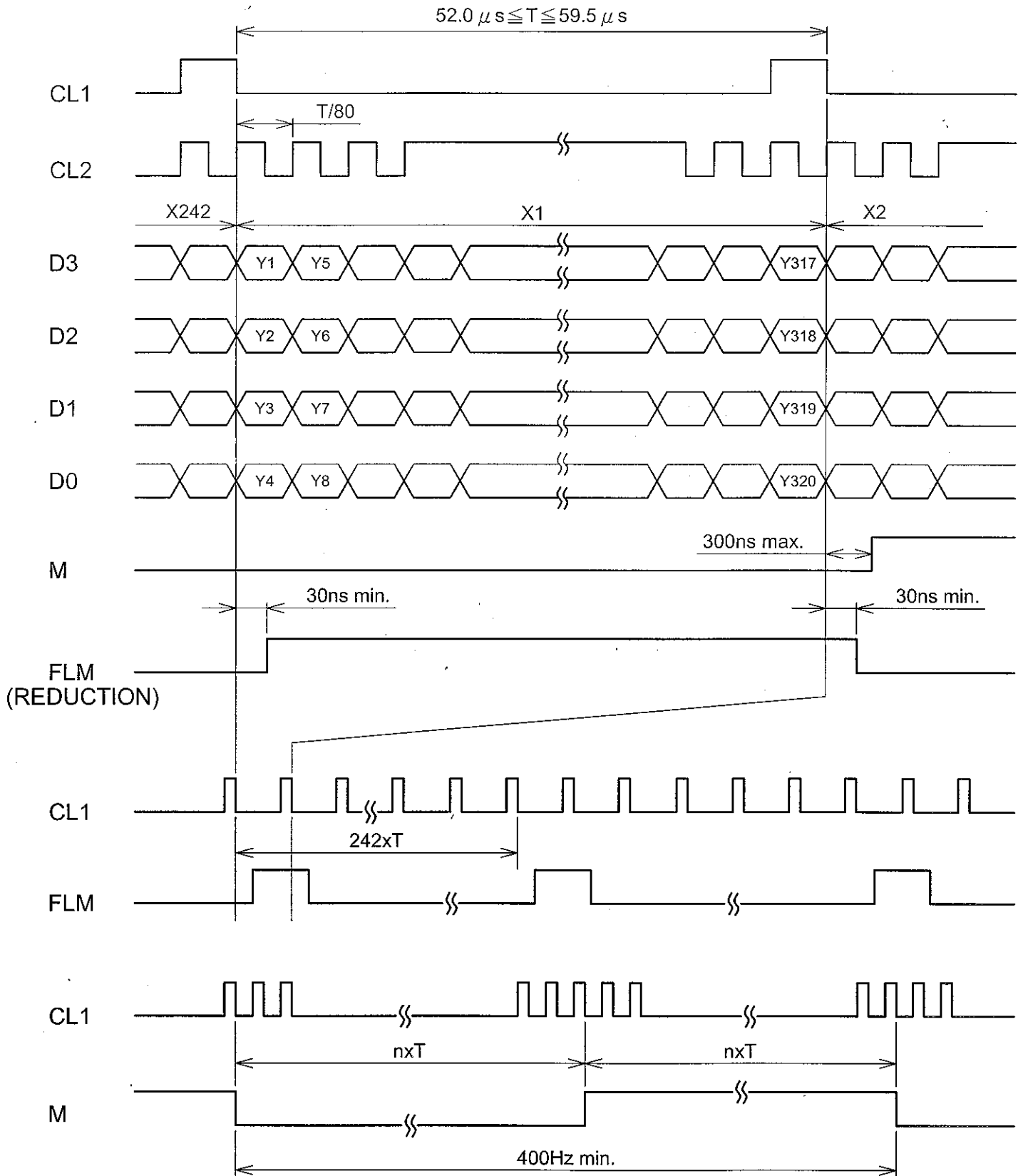

Note 1 : M signal should be kept 400Hz min. and 50% duty.

Note 2 : HITACHI recommend  $n \times CL1$  pulses of M signal 50%.

$n=13$

## 8.2 TIMING CHARACTERISTICS

PARAMETER	SYMBOL	MIN.	TYP.	MAX.	UNIT	CONDITION
Shift Clock Period	tWCK	125	-	-	ns	$t_r, t_f \leq 11\text{ns}$
Shift Clock "H" Pulse Width	tWCKH	51	-	-	ns	
Shift Clock "L" Pulse Width	tWCKL	51	-	-	ns	
Data Setup Time	tDS	30	-	-	ns	
Data Hold Time	tDH	40	-	-	ns	
Latch Pulse "H" Pulse Width	tWLPH	51	-	-	ns	
Shift Clock Rise to Latch Pulse Rise Time	tLD	0	-	-	ns	
Shift Clock Rise to Latch Pulse Fall Time	tSL	51	-	-	ns	
Latch Pulse Rise to Shift Clock Rise Time	tLS	51	-	-	ns	
Latch Pulse Fall to Shift Clock Fall Time	tLH	51	-	-	ns	
Input Signal Rise Time	$t_r$	-	-	50	ns	(Note 1)
Input Signal Fall Time	$t_f$	-	-	50	ns	(Note 1)
DOFF Removal Time	tSD	100	-	-	ns	
DOFF Enable Pulse Time	tWDL	1.2	-	-	$\mu\text{s}$	
"FLM" Set Up Time	tFS	100	-	-	ns	-
"FLM" Hold Time	tFH	30	-	-	ns	-

Note 1 :  $(t_{WCK} - t_{WCKH} - t_{WCKL}) / 2$  is the maximum in the case of high speed operation.

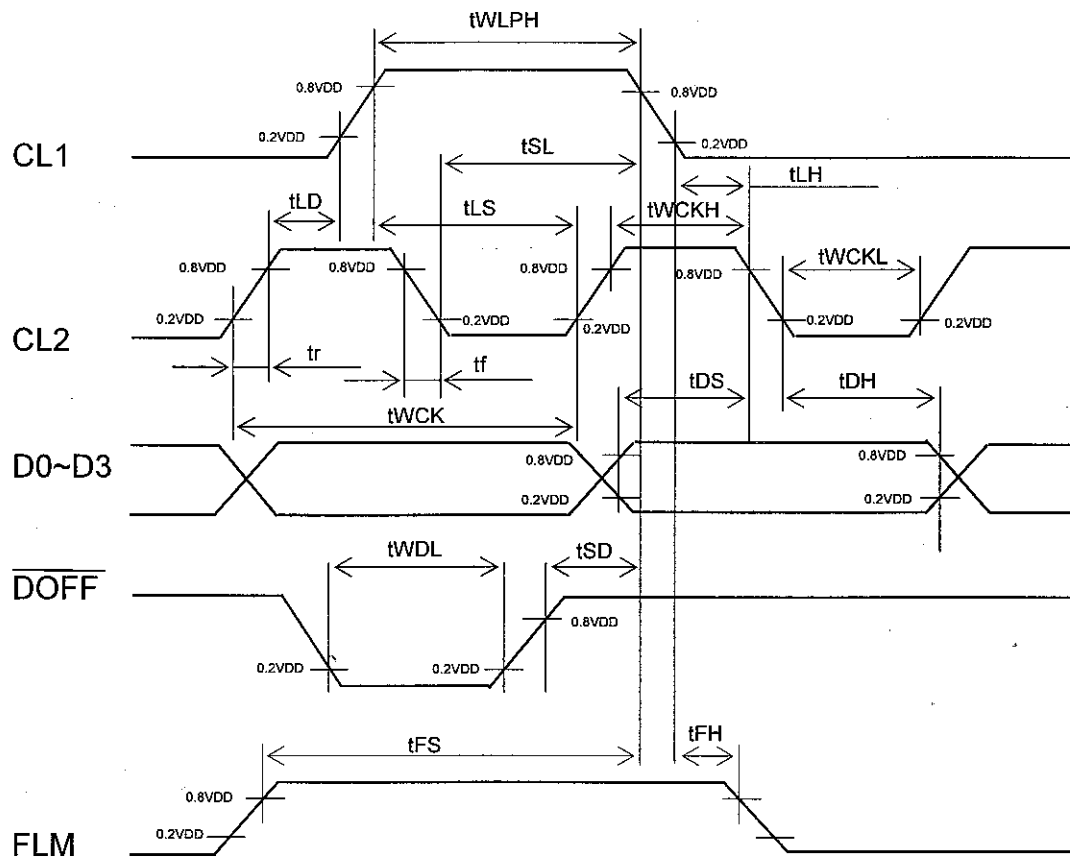

### 8.3 TIMING OF POWER SUPPLY AND INTERFACE SIGNAL

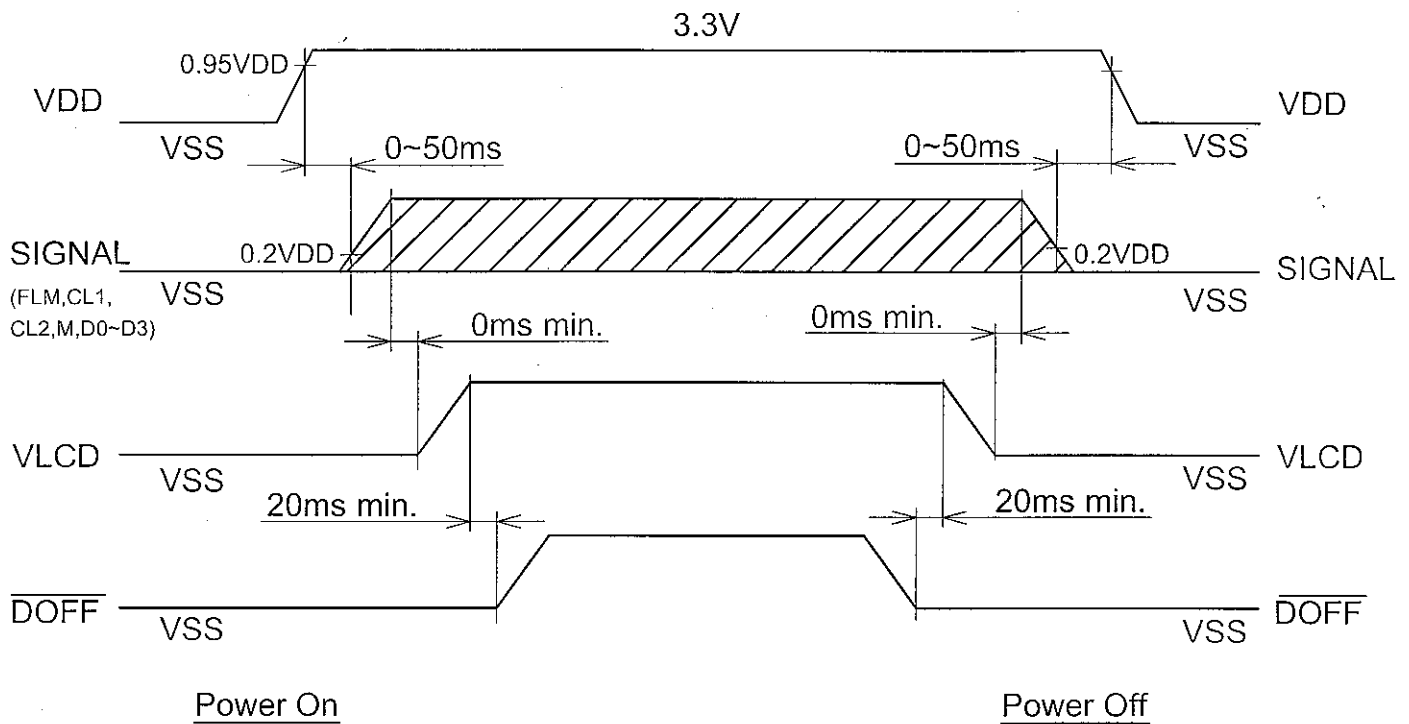

Note 1:  $\overline{\text{DOFF}}$  function takes priority even if the input signal status becomes irregular immediately after VDD power-on.

Note 2: Please keep the specified sequence because wrong sequence may cause permanent damage to the LCM.

### 8.4 POWER SUPPLY FOR LCM

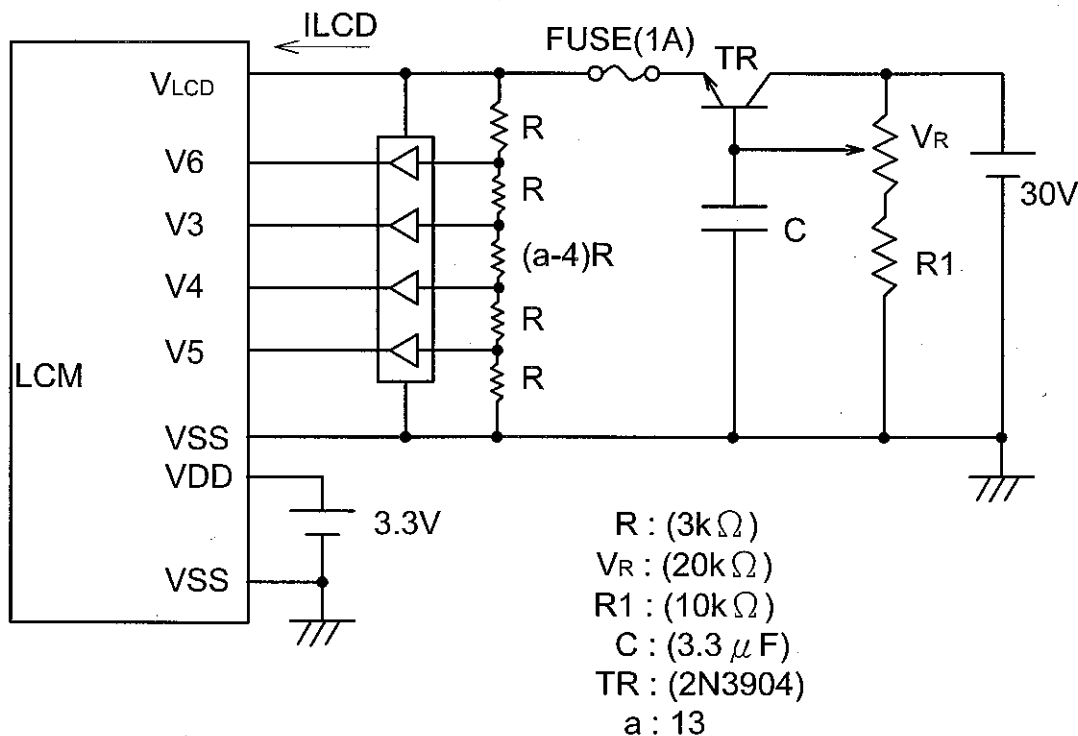

# 9. OUTLINE DIMENSIONS

## 9.1 OUTLINE DIMENSIONS

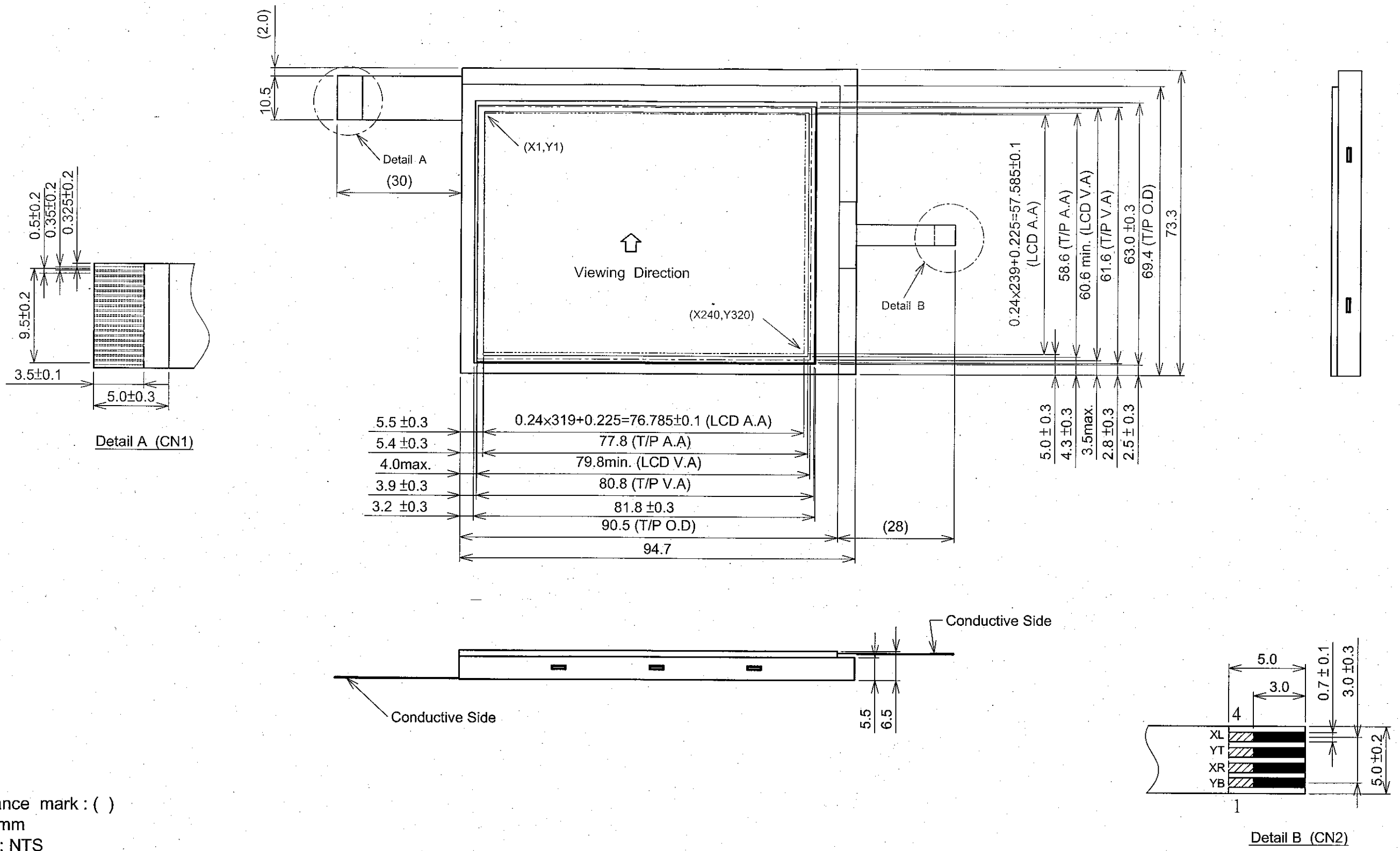

**Notes:**

1. Reference mark : ( )
2. Unit : mm
3. Scale : NTS
4. Unmarked Tolerance : ±0.5mm
5. Measurement when adding  $9.8 \times 10^4$  Pa at the measuring point

## 9.2 DISPLAY PATTERN

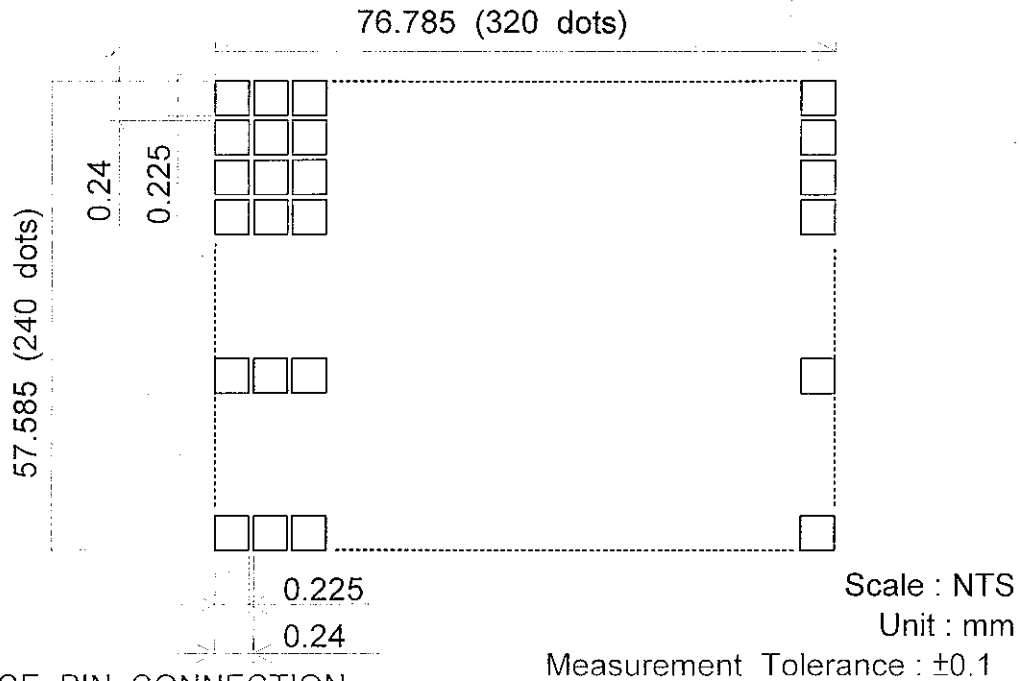

## 9.3 INTERFACE PIN CONNECTION

### 9.3.1 CN1 : LCM I/F (0.5mm PITCH , 20PINS FPC)

PIN No.	SYMBOL	FUNCTION
1	FLM	Frame start signal data signal of the shift register of the Com driver
2	V6	Bias voltage for non-select (Com driver)
3	VDD	Power supply for logic
4	V5	Bias voltage for non-select (Com driver)
5	$\overline{\text{DOFF}}$	Hi : Display on ; Low : Display off
6	VSS	Ground
7	M	Switch signal to convert LCD driver waveform into AC
8	CL1	1) Latch pulse of display data 2) Shift clock for Com driver
9	VLCD	Power supply for LCD
10	V3	Bias voltage for non-select (Seg driver)
11	VDD	Power supply for logic
12	V4	Bias voltage for non-select (Seg driver)
13	VSS	Ground
14	CL2	Clock pulse for Seg shift
15	D0	Input data signal
16	D1	Input data signal
17	D2	Input data signal
18	D3	Input data signal
19	VLED(+)	Power supply for LED backlight
20	VLED(-)	Power supply for LED backlight

Suitable connector : Molex / 52745-2090 or 52746-2090

### 9.3.2 CN2 : I/F (1.0mm PITCH , 4PINS T/P)

INTERFACE	PIN No.	SIGNAL	FUNCTION	
T/P	CN2	1	YB	Analog Signal from Digitizer Bottom
		2	XR	Analog Signal from Digitizer Right
		3	YT	Analog Signal from Digitizer Top
		4	XL	Analog Signal from Digitizer Left

## 10. APPEARANCE STANDARD

### 10.1 APPEARANCE INSPECTION CONDITION

Visual inspection should be done under the following condition.

- (1) The inspection should be done in a dark room.
- (2) The CFL should be lighted with the prescribed inverter.
- (3) The distance between eyes of an inspector and the LCD module is 25cm.
- (4) The viewing zone is shown the figure.

Viewing angle  $\leq 45^\circ$ .

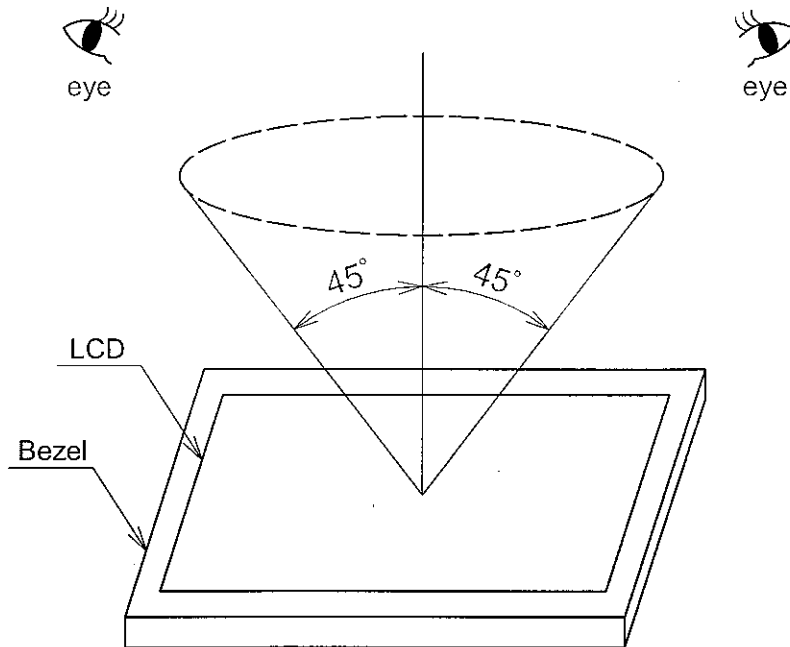

### 10.2 DEFINITION OF ZONE

A zone : Within the LCD active area line specified at page 9-1/1 of this document.

B zone : Area between the LCD viewing area line and the LCD active area line specified at page 9-1/1 of this document.

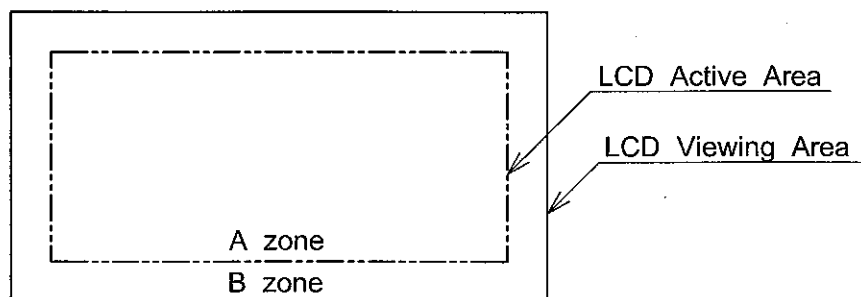



### 10.3 APPEARANCE SPECIFICATION

\*) If the problem occurs about this item, the responsible person of both party (customer and HITACHI) will discuss more detail.

No.	ITEM	CRITERIA			A	B	
L C D	Scratches	Distinguished one is not acceptable (to be judge by HITACHI limit sample)			*	-	
	Dent	Same as above			*	-	
	Wrinkles in Polarize	Same as above			*	-	
	Bubbles	Average diameter D(mm)		Maximum number acceptable		○	-
		$D \leq 0.2$		Ignore			
		$0.2 < D \leq 0.3$		12			
		$0.3 < D \leq 0.5$		3			
		$0.5 < D$		None			
	(Note 1)						
	Stains, Foreign Materials Dark Spot	Filamentous			○	*	
		Length L(mm)	Width W(mm)	Maximum number acceptable			
		$L \leq 2.0$	$W \leq 0.03$	Ignore			
		$L \leq 3.0$	$0.03 < W \leq 0.05$	6			
		-	$0.05 < W$	According to type of Round			
		Round					
		Average diameter D(mm)	Maximum number acceptable	Minimum space			
		$D \leq 0.2$	Ignore	-			
		$0.2 < D \leq 0.33$	8	10 mm			
		$0.33 < D$	None	-			
	(Note 1,2)	Those wiped out easily are acceptable			○	-	
	Color Tone	To be judged by HITACHI limit sample			○	-	
	Color Uniformity	Same as above			○	-	
	Pinhole	Average diameter D(mm)		Maximum number acceptable		○	-
$D \leq 0.15$		Ignore					
$0.15 < D \leq 0.3$		10					
$0.3 < D$		None					
(Note 1)							
Contrast Irregularity (Spot)	Average diameter D(mm)	Contrast	Maximum number acceptable	Minimum space	○	-	
	$D \leq 0.25$		Ignore	-			
	$0.25 < D \leq 0.35$		To be Judge by HITACHI Standard	10			20mm
	$0.35 < D \leq 0.5$			4			20mm
	$0.5 < D$		None	-			
(Note 1)							

No.	ITEM	CRITERIA				A	B
L C D	Contrast Irregularity (Line) (A Pair of Scratch)	Width W(mm)	Length L(mm)	Maximum acceptable number	Minimum space	○	-
		$W \leq 0.25$	$L \leq 1.2$	2	20mm		
		$W \leq 0.2$	$L \leq 1.5$	3	20mm		
		$W \leq 0.15$	$L \leq 2.0$	3	20mm		
		$W \leq 0.1$	$L \leq 3.0$	4	20mm		
(Note 2)	The whole number $\leq 6$						
	Rubbing Scratch	To be judged by HITACHI standard				○	-

Note (1)

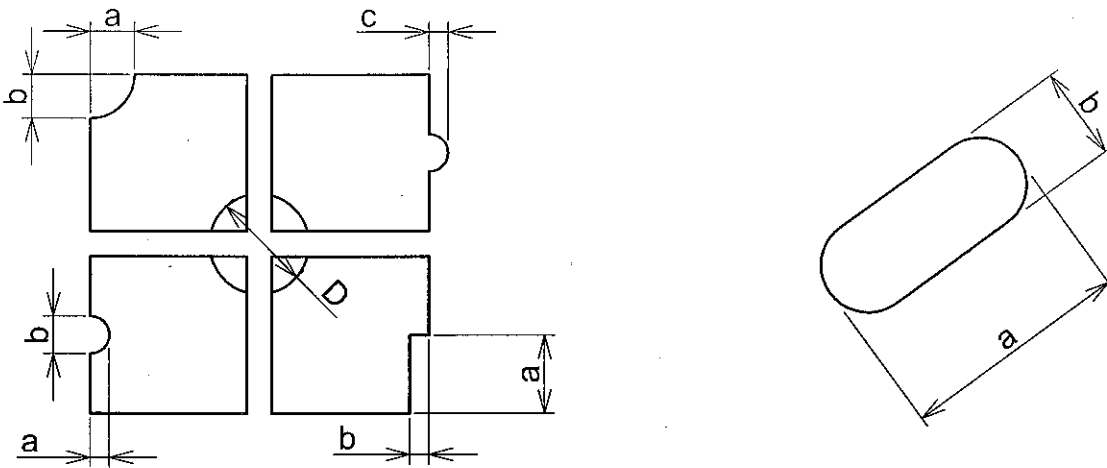

$$\frac{a+b}{2} = D \dots \text{Average Diameter}$$

$$c \dots \text{Salient}$$

(2) Definition of length L and width W

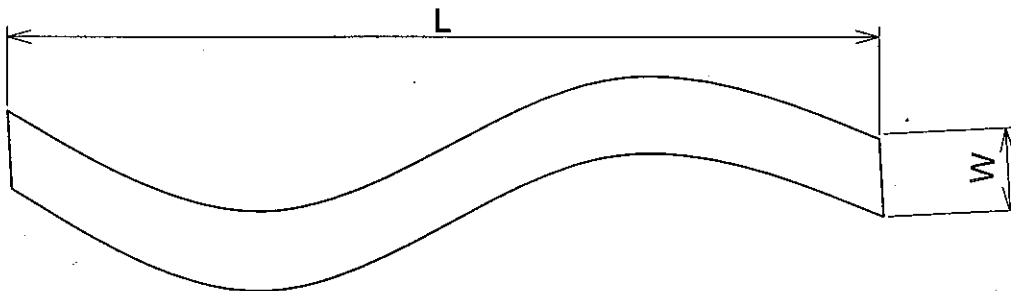

## 11. PRECAUTION IN DESIGN

### 11.1 LC DRIVING VOLTAGE (VLCD) AND VIEWING ANGLE RANGE.

Setting VLCD out of the recommended condition will be a cause for a change of viewing angle range.

### 11.2 CAUTION AGAINST STATIC CHARGE

As this module is provided with C-MOS LSI, the care to take such a precaution as to grounding the operator's body is required when handling it.

### 11.3 POWER ON SEQUENCE

Input signals should not be applied to LCD module before power supply voltage is applied and reaches to specified voltage ( $3.3 \pm 10\%$ ). If above sequence is not kept, C-MOS LSI of LCD modules may be damaged due to latch up problem.

### 11.4 PACKING

- (1) No leaving products is preferable in the place of high humidity for a long period of time. For their storage in the place where temperature is  $35^{\circ}\text{C}$  or higher, special care to prevent them from high humidity is required. A combination of high temperature and high humidity may cause them polarization degradation as well as bubble generation and polarizer peel-off. Please keep the temperature and humidity within the specified range for use and storage.
- (2) Since upper polarizers and lower aluminum to be easily damaged, they should be handled with full care so as not to get them touched, pushed or rubbed by a piece of glass, tweezers and anything else which are harder than a pencil lead 3H.
- (3) As the adhesives used for adhering upper/lower polyester and aluminum plates are made of organic substances which will deteriorated by a chemical reaction with such chemicals as acetone, ethanol and isopropyl alcohol. The following solvents are recommended for use:  
normal hexane  
Please contact us when it is necessary for you to use chemicals other than the above.

- (4) Lightly wipe to clean the dirty surface with absorbent cotton waste or other soft material like chamois, soaked in the chemicals recommended without scrubbing it hardly. To prevent the display surface from damage and keep the appearance in good state, it is sufficient, in general, to wipe it with absorbent cotton.
- (5) Immediately wipe off saliva or water drop attached on the display area because its long period adherence may cause deformation or faded color on the spot.
- (6) Foggy dew deposited on the surface and contact terminals due to coldness will be cause for polarizer damage, stain and dirt on product.  
When necessary to take out the products from some place at low temperature for test, etc. It is required for them to be warmed up in a container once at the temperature higher than that of room.
- (7) Touching the display area and contact terminals with bare hands and contaminating them are prohibited, because the stain on the display area and poor insulation between terminals are often caused by being touched by bare hands.  
( There are some cosmetics detrimental to polarizers. )
- (8) In general the quality of glass is fragile so that it tends to be cracked or chipped in handling, specially on its periphery. Because be careful not to give it sharp shock caused by dropping down, etc.

## 11.5 CAUTION FOR OPERATION

- (1) It is an indispensable condition to drive LCD within the specified voltage limit since the higher voltage than the limit causes the shorter LCD life. An electrochemical reaction due to direct current causes LCD's undesirable deterioration, so that the use of direct current driver should be avoided.
- (2) Response time will be extremely delayed at lower temperature than the specified operating temperature range and on the other hand LCD's show dark blue Color in then however those phenomena do not mean Malfunction or out of order with LCD's which will come back in the specified operation temperature range.
- (3) If the display area is pushed hard during operation, some font will be abnormally displayed but it resumes normal condition after turning off once.
- (4) A slight dew depositing on terminals is a cause for electrochemical reaction resulting in terminal open circuit.  
Please operate the LCD module under the relative condition of 40°C 85%RH.

## 11.6 STORAGE

In case of storing for a long period of time (for instance ,for years) for the purpose of replacement use, the following ways are recommended.

- (1) Storage in a polyethylene bag with the opening sealed so as not to enter fresh air outside in it, and with no desiccant.
- (2) Placing in a dark place where neither exposure to direct sunlight nor light is, keeping temperature in the range from 0°C to 35°C .
- (3) Storing with no touch on polarizer surface by anything else.  
(It is recommended to store them as they have been contained in the inner container at the time of delivery from us.)

## 11.7 SAFETY

- (1) It is recommendable to crash damaged or unnecessary LCD's into pieces and wash off liquid crystal by either of solvents such as acetone and ethanol, which should be burned up later.
- (2) When any liquid leaked out of a damage glass cell comes in contact with your hands, please wash it off well with soap and water.

## 12. DESIGNATION OF LOT MARK

Lot Mark

Lot mark is consisted of 4 digital number

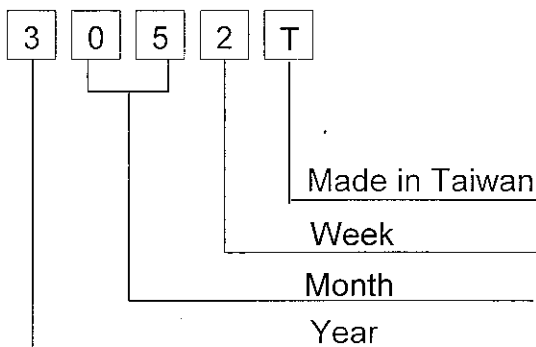

YEAR	FIGURE IN LOT MARK:
2008	8
2009	9
2010	0
2011	1
2012	2

Note 1 : Some products have alphabet at the end or the first.

MONTH	FIGURE IN LOT MARK	MONTH	FIGURE IN LOT MARK
Jan.	01	Jul.	07
Feb.	02	Aug.	08
Mar.	03	Sep.	09
Apr.	04	Oct.	10
May	05	Nov.	11
Jun.	06	Dec.	12

WEEK (DAY IN CALENDAR)	FIGURE IN LOT MARK
1~7	1
8~14	2
15~21	3
22~28	4
29~31	5

Location of lot mark : On the back side of LCM

3 0 5 2 T

### 13. PRECAUTION FOR USE

- (1) A limit sample should be provided by the both parties on an occasion when the both parties agreed its necessity. Judgement by a limit sample shall take effect after the limit sample has been established and confirmed by the both parties.
- (2) On the following occasions, the handling of the problem should be decided through discussion and agreement between responsible persons of the both parties.
  - (1) When a question is arisen in the specifications.
  - (2) When a new problem is arisen which is not specified in this specifications.
  - (3) When an inspection specifications change or operating condition change in customer is reported to HITACHI, and some problem is arisen in this specification due to the change.
  - (4) When a new problem is arisen at the customer's operating set for sample evaluation in the customer site.

The precaution that should be observed when handling LCM have been explained above. If any points are unclear or if you have any requests , please contact HITACHI.

## 14. DIGITIZER TECHNICAL SPECIFICATION

### 14.1 RATINGS

#### 14.1.1 ABSOLUTE MAXIMUM RATINGS

ITEM	SPECIFICATIONS	COMMENT
Operating Voltage	7VDC max.	
Contact Current	20mA max.	
Operating Temperature	-5~60°C (20~90%RH)	Without
Storage Temperature	-20~70°C (20~90%RH)	Condensation

#### 14.1.2 OPERATING CONDITIONS

ITEM	SPECIFICATIONS
Operating Voltage	5VDC
Contact Current	10~20mA
Actuation Force	1.2N max(R0.8mm,Poly-acetal Pen)

### 14.2 MECHANICAL STRENGTH

#### 14.2.1 INPUT METHOD & ACTUATION FORCE

INPUT METHOD	ACTUATION FORCE	COMMENT
Pen	1.2N max.	R0.8mm,Poly-acetal Pen
Finger	1.2N max.	R8.0mm, Silicone Rubber

#### 14.2.2 SURFACE HARDNESS

2H min. Test Method : JIS-K5400.

### 14.3 OPTICAL CHARACTERISTICS

14.3.1 TRANSPARENCY : 80% min.

14.3.2 HAZE : 4~8%

14.3.3 NEWTON RING : None Appearance.

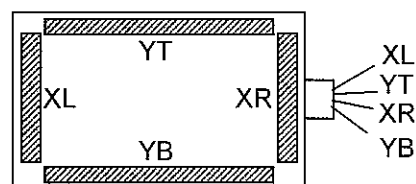

### 14.4 ELECTRICAL CHARACTERISTICS

#### 14.4.1 CONDUCTIVE RESISTANCE

TERMINAL	CONDUCTIVE RESISTANCE
XR-XL	220~670Ω
YT-YB	220~840Ω

#### 14.4.2 INSULATION RESISTANCE

TERMINAL	SPECIFICATIONS
X-Y	20MΩ min.

Operating Voltage : 25VDC

#### 14.4.3 BOUNCE CHATTERING

10ms max.



### 14.4.6 LINEARITY

(1) SPECIFICATION :  $\pm 1.5\%$  max.

(2) TESTING CIRCUIT

(a) X Axis linearity testing method (With Tip Radius 0.8, Poly-acetal Pen).

$V_{XR-XL}=5V$  ,  $V_{OUT}=V_{YT}$ .

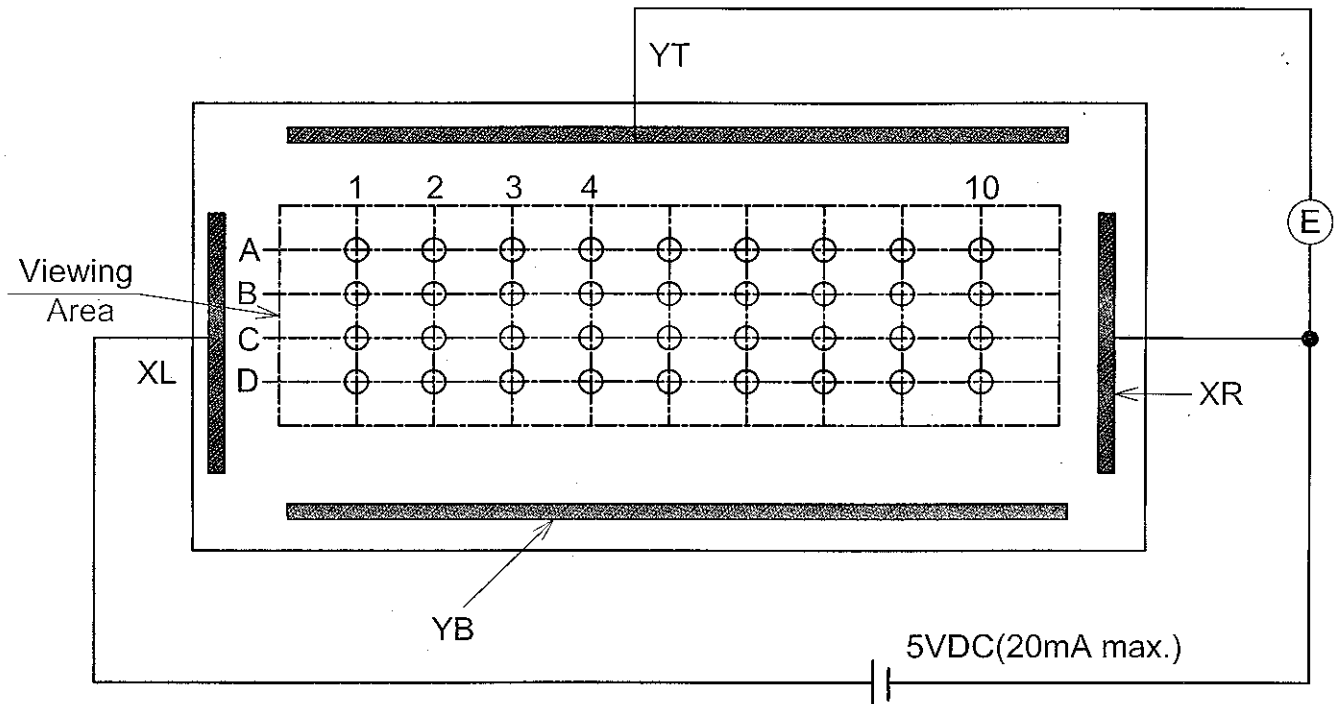

(b) Y Axis linearity method  $V_{YT-YB}=5V$  ,  $V_{OUT}=V_{XL}$

(3) CALCULATION

(a) X Axis Linearity

$$\text{LINEARITY} = \frac{\Delta E \text{ max.}}{EA1 - EA10} \times 100(\%)$$

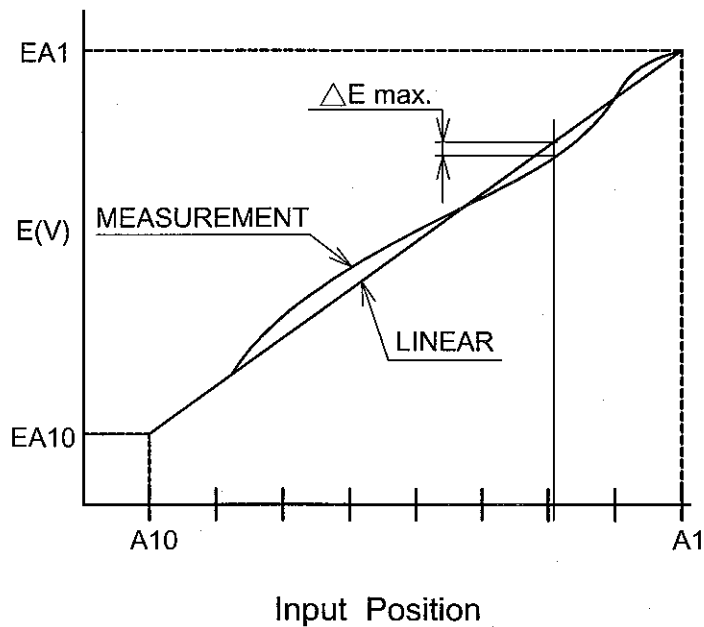

### 14.5 ENVIRONMENTAL TESTING

ITEM	CONDITIONS	CRITERIA
High Temperature Storage	70°C : 240h & 25°C : 24h	After testing must to meet the specifications of the electrical, mechanical & optical characteristics.
Low Temperature Storage	-20°C : 240h & 25°C : 24h	
Temperature Cycle	-30°C ↔ 80°C : 10cycles (30) (60) (30) : minutes & 25°C : 24h (Without condensation)	
Humidity Storage	60°C, 90%RH. 240h & 25°C, 24h	
Durability for Point Selections	250g (Speed : 3times/s) R0.8mm, poly-acetal pan 1 million activations	
Durability for Hand Writing	250g, R0.8mm, poly-acetal pan 100 thousand katakana characters in a 20mm x 20mm place (speed : 3000 characters/h)	

### 14.6 APPEARANCE SPECIFICATION

#### 14.6.1 VIEWING AREA

Please refer page 10-2/3, 10.3 appearance specification

#### 14.6.2 OUT OF VIEWING AREA

ITEM	SPECIFICATIONS
Conducting Print Pattern Indentation	
Conducting Print Pattern Gap	
Within Viewing Area Conducting Paste Entrance	

### 14.6.3 GLASS INDENTATION

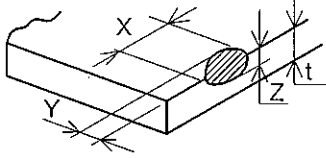
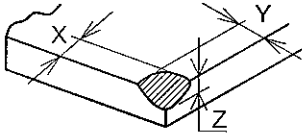
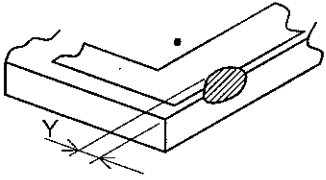
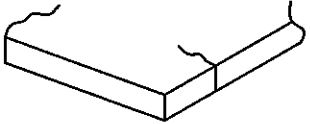
ITEM	SPECIFICATIONS							
Common Indentation		<table border="1" data-bbox="1054 248 1337 338"> <tr> <td>X</td> <td>Y</td> <td>Z</td> </tr> <tr> <td>≤5.0</td> <td>≤3.0</td> <td>≤t</td> </tr> </table> <p data-bbox="1046 371 1401 477">But, indentation can not including seal area. t: Glass thickness.</p>	X	Y	Z	≤5.0	≤3.0	≤t
X	Y	Z						
≤5.0	≤3.0	≤t						
Corner Broken		<table border="1" data-bbox="1054 539 1337 629"> <tr> <td>X</td> <td>Y</td> <td>Z</td> </tr> <tr> <td>≤2.0</td> <td>≤5.0</td> <td>≤t</td> </tr> </table> <p data-bbox="1046 674 1401 741">But, indentation can not including seal area.</p>	X	Y	Z	≤2.0	≤5.0	≤t
X	Y	Z						
≤2.0	≤5.0	≤t						
Indentation Within Pattern		<p data-bbox="938 819 1441 925">Y ≤ 1 is ignore But, must to meet the specification of conducting pattern indentation.</p>						
Proceeding Crack		<p data-bbox="986 1137 1058 1171">None</p>						

### 14.6.4 OTHERS

- (1) There is not any wrinkle on the pet film.
- (2) There is not any fish-eye and Newton ring.